

MAINE TURNPIKE AUTHORITY

MAINE TURNPIKE

CONTRACT DOCUMENTS

CONTRACT 2018.20

YORK TOLL PLAZA
MILE 8.8

NOTICE TO CONTACTORS

PROPOSAL

CONTRACT AGREEMENT

CONTRACT BOND

FINAL LIEN AND CLAIM WAIVER AND AFFIDAVIT

SPECIFICATIONS

MAINE TURNPIKE AUTHORITY

SPECIFICATIONS

The Specifications are divided into three parts:
Part I - Supplemental Specifications, Part II - Special Provisions
and Part III - Division 800.

The Maine Turnpike Supplemental Specifications are additions
and alterations to the 2014 Maine Department of
Transportation Standard Specifications. See Subsection 100.1

TABLE OF CONTENTS

	<u>PAGE</u>
NOTICE TO CONTRACTORS	N-1
PROPOSAL.....	P-1
CONTRACT AGREEMENT	C-1
CONTRACT BOND.....	CB-1
FINAL LIEN AND CLAIM WAIVER AND AFFIDAVIT	F-1
 <u>ARRANGEMENT OF SPECIFICATIONS</u>	
PART I – SUPPLEMENTAL SPECIFICATIONS	SS-1
PART II - SPECIAL PROVISIONS.....	SP-1
PART III – DIVISION 800	
PART IV - APPENDICES	AP-1

MAINE TURNPIKE AUTHORITY

NOTICE TO CONTRACTORS

Sealed Proposals will be received by the Maine Turnpike Authority for:

CONTRACT 2018.20

YORK TOLL PLAZA

MILE 8.8

that at the office of the Maine Turnpike Authority, 2360 Congress Street, Portland, ME, until 11:00 a.m., prevailing time as determined by the Authority on October 11, 2018 at which time and place the Proposals will be publicly opened and read. Bids will be accepted from Contractors prequalified by the Maine Department of Transportation for Bridge Construction Projects. All other bids will be rejected. In addition, contractors submitting bids must be themselves or utilize a Highway subcontractor pre-qualified by the Maine Department of Transportation for Highway, a building subcontractor pre-qualified by the Maine Department of Transportation for Buildings and an electrical subcontractor prequalified by the Maine Department of Transportation for Traffic Signals and Lighting Projects.

Contractors not currently prequalified by MaineDOT for Bridge projects can seek prequalification for this project prior to the bid by submitting the prequalification application included with this notice directly to the Authority at the above address. Prequalification applications will be accepted for this project until September 14, 2018 at 4:30 PM with a decision on prequalification status by September 21, 2018 at 4:30 PM. Contractors not currently prequalified by MaineDOT for Bridge Projects or Contractors not prequalified by the MTA for Bridge projects for this project by September 21, 2018 at 4:30 PM will not be permitted to submit a bid as the general Contractor for this project.

Subcontractors not currently prequalified by MaineDOT can seek prequalification for this project prior to the bid by submitting the prequalification application included with this notice directly to the Authority at the above address. Post bid qualification in accordance with the MTA supplemental Specifications will be allowed for Sub Contractors only.

This Project includes a wage determination developed by the State of Maine Department of Labor.

The Project consists of highway, structures, building and site work required to construct a new toll facility. The work at Mile 8.8 consists of constructing six (6) open, high-speed (70 mph) E-ZPass center lanes (3 in each direction) with overhead open frame gantries with electronic toll collection equipment, nine (9) cash lanes with toll booths (4 northbound and 5 southbound) with canopies, reconstruction of mainline to accommodate approach and departure lanes at the new toll plaza, construction of a precast pedestrian tunnel for employee access and utilities, driveway from Chases Pond Road, parking lot and Administration Building. The work includes earthwork, pavement, concrete, signing, overhead sign structures, concrete barrier, guardrail, mechanical work, electrical work, lighting and lightning suppression systems. The work also includes the

installation of tolling equipment in the tunnel, canopy, and toll booth, maintenance of traffic and all other work incidental thereto in accordance with the Plans and Specifications.

Plans and Contract Documents will not be available on the MTA website until September 5, 2018. Beginning on September 10, 2018 they may be examined by prospective Bidders weekdays between 8:00 a.m. and 4:30 p.m. at the office of the Maine Turnpike Authority, 2360 Congress Street, Portland, Maine. Beginning on September 10, 2018 the **full size Plans** and Contract Documents may be obtained from the Authority upon payment of Three Hundred and fifty (\$350.00) Dollars for each set, which payment will not be returned and the **half size Plans** and Contract Documents may be obtained from the Authority upon payment of Two Hundred and fifty (\$250.00) Dollars for each set, which payment will not be returned. Checks shall be made payable to: Maine Turnpike Authority. Plans and contract documents will not be shipped. The Plans, Contract Documents and Geotechnical Report may also be downloaded from a link on our website at <http://www.maineturnpike.com/project-and-planning/Construction-Contracts.aspx>.

For general information regarding Bidding and Contracting procedures, contact Nate Carll, Purchasing Manager, at (207) 482-8115. For information regarding Schedule of Items, plan holders list and bid results, visit our website at <http://www.maineturnpike.com/project-and-planning/Construction-Contracts.aspx>. For Project specific information, fax all questions to Nate Carll, Purchasing Manager, at (207) 871-7739 or email ncarll@maineturnpike.com. Responses will not be prepared for questions received by telephone. Bidders shall not contact any other Authority staff or Consultants for clarification of Contract provisions, and the Authority will not be responsible for any interpretations so obtained.

All work shall be governed by the Specifications entitled "State of Maine, Department of Transportation, Standard Specifications, Revision of November 2014", "Standard Details, Revision of November 2014" and "Best Management Practices for Erosion and Sediment Control", latest issue. Copies and recent updates to these publications can be downloaded at: <http://www.maine.gov/mdot/contractors/publications/>.

Proposals must be accompanied by an original bid bond, certified or cashier's check payable to the Maine Turnpike Authority in an amount not less than Five (5%) Percent of the Total Amount in the Proposal, but not less than \$500.00. The Bidder to whom a Contract is awarded will be required to furnish a Surety Corporation Bond, satisfactory to the Authority, on the standard Contract Bond form of the Authority, for a sum not less than the Total Amount of the Proposal.

Proposals must be made upon the Proposal Forms furnished by the Authority separately with the Contract Documents, and must be enclosed in a sealed envelope bearing the name and address of the Bidder, the name of the Contract, and the date and time of Proposal opening on the outside.

A pre-bid conference will be held on September 18, 2018 at 10:00 a.m. at the Maine Turnpike Authority, 2360 Congress Street, Portland, Maine.

The Authority reserves the unqualified right to reject any or all Proposals and to accept that Proposal which in its sole judgment will under all circumstances serve its best interest.

MAINE TURNPIKE AUTHORITY

Nate Carll
Purchasing Manager
Maine Turnpike Authority
Portland, Maine

MAINE TURNPIKE AUTHORITY
MAINE TURNPIKE

PROPOSAL

CONTRACT 2018.20

YORK TOLL PLAZA
MILE 8.8

MAINE TURNPIKE AUTHORITY

PROPOSAL

CONTRACT 2018.20

YORK TOLL PLAZA

MILE 8.8

TO MAINE TURNPIKE AUTHORITY:

The Project consists of highway, structures, building and site work required to construct a new toll facility and demolish the existing toll facility. The work at Mile 8.8 consists of constructing six (6) open, high-speed (70 mph) E-ZPass center lanes (3 in each direction) with overhead open frame gantries with electronic toll collection equipment, nine (9) cash lanes with toll booths (4 northbound and 5 southbound) with canopies, reconstruction of mainline to accommodate approach and departure lanes at the new toll plaza, construction of a precast pedestrian tunnel for employee access and utilities, driveway from Chases Pond Road, parking lot and Administration Building. The work at Mile 7.3 consists of demolition of the existing 17-lane toll plaza, tunnel, administration building, removal of existing utilities and driveway, and reconstruction of the existing facility to a three (3) lane highway southbound and a four (4) lane highway northbound. The work includes earthwork, pavement, concrete, toll plaza and tunnel demolition, signing, overhead sign structures, concrete barrier, guardrail, mechanical work, electrical work, lighting and lightning suppression systems. The work also includes the installation of tolling equipment in the tunnel, canopy, and toll booth, maintenance of traffic and all other work incidental thereto in accordance with the Plans and Specifications.

This Work will be done under a Contract known as Contract 2018.20 according to the Plans and Specifications which are on file in the office of the Maine Turnpike Authority, 2360 Congress Street, Portland, Maine.

On the acceptance of this Proposal for said Work, the undersigned will give the required bond with good security conditioned for the faithful performance of said Work, according to said Plans and Specifications, and the doing of all other work required by said Specifications for the consideration herein named and with the further condition that the Maine Turnpike Authority shall be saved harmless from any and all damages that might accrue to any person, persons or property by reason of the carrying out of said Work, or any part thereof, or by reason of negligence of the undersigned, or any person or persons under his employment and engaged in said Work.

The undersigned hereby declares that he/she has carefully examined the Plans, Specifications and other Contract Documents, and that he/she will contract to carry out and complete the said Work as specified and delineated at the price per unit of measure for each scheduled item of Work stated in the Schedule of Prices as follows:

It is understood that the TOTAL AMOUNT stated by the undersigned in the following Schedule of Prices is based on approximate quantities and will be used solely for the comparison of bids, and that the quantities stated in the Schedule of Prices for the various items are estimates only and may be increased or decreased all as provided in the Specifications.

**SCHEDULE OF BID PRICES
 CONTRACT 2018.20
 YORK TOLL PLAZA
 MILE 8.8**

Item No.	Item Description	Units	Approx. Quantities	Unit Prices in Numbers		Bid Amount in Numbers	
				Dollars	Cents	Dollars	Cents
201.11	Clearing	AC	17				
202.15	Removing Existing Manhole or Catch Basin	EA	22				
202.151	Abandoning Existing Manhole or Catch Basin	EA	10				
202.16	Removing Existing Pipe	LF	575				
202.161	Abandoning Existing Pipe	LF	680				
202.202	Removing Pavement Surface	SY	88,000				
202.205	Rumble Strips - Shoulder	LF	35,500				
202.206	Removing Rumble Strips	LF	6,100				
202.60	Abandon Monitoring Well	EA	2				
203.20	Common Excavation	CY	128,500				
203.21	Rock Excavation	CY	47,300				
203.213	Drilling and Blasting of Solid Rock Subgrade	SY	5,700				
CARRIED FORWARD:							

Item No.	Item Description	Units	Approx. Quantities	Unit Prices in Numbers		Bid Amount in Numbers	
				Dollars	Cents	Dollars	Cents
BROUGHT FORWARD:							
203.24	Common Borrow	CY	43,400				
203.245	Clay Borrow	CY	55				
203.25	Granular Borrow	CY	7,400				
203.35	Crushed Stone Fill 3/4-Inch	CY	550				
205.51	Widening of Existing Shoulder, Plan Quantity	SY	315				
206.07	Structural Rock Excavation - Drainage & Minor Structures	CY	3,200				
206.082	Structural Earth Excavation - Major Structures, Plan Quantity	CY	2,450				
206.092	Structural Rock Excavation - Major Structures	CY	1,980				
304.10	Aggregate Subbase Course-Gravel	CY	115,500				
304.14	Aggregate Base Course - Type A	CY	26,170				
304.15	Aggregate Base Course - Type B	CY	200				
403.207	Hot Mix Asphalt, 19.0 mm Nominal Maximum Size	T	39,750				
403.208	Hot Mix Asphalt, 12.5 mm Nominal Maximum Size	T	550				
CARRIED FORWARD:							

Item No.	Item Description	Units	Approx. Quantities	Unit Prices in Numbers		Bid Amount in Numbers	
				Dollars	Cents	Dollars	Cents
BROUGHT FORWARD:							
403.2081	Hot Mix Asphalt - 12.5 mm Nominal Maximum Size (Polymer Modified)	T	14,300				
403.209	Hot Mix Asphalt 9.5 mm Nominal Maximum Size (sidewalks, drives, islands & incidentals)	T	50				
403.211	Hot Mix Asphalt (Shim)	T	11,500				
403.213	Hot Mix Asphalt 12.5 mm Nominal Maximum Size (Binder)	T	14,240				
409.15	Bituminous Tack Coat - Applied	G	17,675				
419.30	Saw Cutting Bituminous Pavement	LF	3,600				
502.231	Structural Concrete, Space Frame and Overhead Sign Structure Pedestals	CY	155				
502.233	Structural Concrete, Canopy Column Foundations	CY	55				
502.265	Structural Concrete, ORT Slabs	CY	300				
502.266	Structural Concrete, Plaza Structural Slabs	CY	470				
502.267	Structural Concrete, Toll Islands	CY	290				
502.268	Structural Concrete, Utility Pits	CY	60				
502.269	Structural Concrete, CCTV Pole Foundations	CY	14				
CARRIED FORWARD:							

Item No.	Item Description	Units	Approx. Quantities	Unit Prices in Numbers		Bid Amount in Numbers	
				Dollars	Cents	Dollars	Cents
BROUGHT FORWARD:							
502.28	Structural Concrete, Rigid Frame Structures [Tunnel]	CY	170				
503.14	Epoxy-Coated Reinforcing Steel, Fabricated and Delivered	LB	136,500				
503.15	Epoxy-Coated Reinforcing Steel, Placing	LB	136,500				
503.18	Glass Fiber Reinforced Polymer (GFRP) Reinforcing Bars, Fabricated and Delivered	LB	48,000				
503.19	Glass Fiber Reinforced Polymer (GFRP) Reinforcing Bars, Placing	LB	48,000				
503.90	Synthetic Fiber Reinforcement	LB	2,100				
504.80	Space Frame Canopies, Fabricated and Delivered	LS	1				
504.81	Space Frame Canopies, Erection	LS	1				
504.90	Space Frame Steel Support Posts and Anchorage Assemblies	LS	1				
504.91	Mounting Bracket Assemblies	LS	1				
506.15	Shop Coating of New Steel	LS	1				
506.9103	Galvanizing	LS	1				
508.14	High Performance Waterproofing Membrane	SY	1,670				
CARRIED FORWARD:							

Item No.	Item Description	Units	Approx. Quantities	Unit Prices in Numbers		Bid Amount in Numbers	
				Dollars	Cents	Dollars	Cents
BROUGHT FORWARD:							
508.15	Membrane Waterproofing	LS	1				
511.091	Temporary Earth Support Systems	LS	1				
515.2011	Pigmented Concrete Protective Coating - Tunnel Walls & Ceiling	SY	1,330				
515.2012	Pigmented Concrete Protective Coating - Tunnel Floor	SY	455				
515.202	Clear Protective Coating for Concrete Surfaces	SY	1,400				
515.23	Epoxy Overlay	SY	250				
526.306	Temporary Concrete Barrier Type I - Supplied by the Authority	LS	1				
526.351	Median Barrier Type I -Precast	LF	7,000				
526.3511	Median Barrier Type IA - Precast	LF	1,800				
526.3512	Median Barrier Type IB - Precast	LF	870				
526.352	Median Barrier Type II - Precast	LF	240				
526.3522	Median Barrier Type II - Cast in Place	LF	140				
526.3531	Median Barrier Type IIIA - Precast	LF	180				
CARRIED FORWARD:							

Item No.	Item Description	Units	Approx. Quantities	Unit Prices in Numbers		Bid Amount in Numbers	
				Dollars	Cents	Dollars	Cents
BROUGHT FORWARD:							
526.3532	Median Barrier Type IIIB - Precast	LF	180				
526.361	Median Barrier Transition Type I - Precast	EA	4				
526.3611	Median Barrier Transition Type IA - Precast	EA	2				
526.3612	Median Barrier Transition Type IB - Precast	EA	2				
526.3613	Median Barrier Transition Type LP-A	EA	8				
526.3614	Median Barrier Transition Type LP-B	EA	10				
526.362	Median Barrier Transition Type II - Precast	EA	16				
526.371	Median Barrier With Mounted Light Pole Type LP-A - Cast in Place	EA	4				
526.372	Median Barrier With Mounted Light Pole Type LP-B - Cast in Place	EA	5				
527.306	Center Barrier Crash Attenuator	EA	2				
527.341	Work Zone Crash Cushions - TL-3	UNIT	5				
534.71	Precast Concrete Tunnel and Tunnel Staircase Structures	LS	1				
603.155	12 Inch Reinforced Concrete Pipe - Class III	LF	420				
CARRIED FORWARD:							

Item No.	Item Description	Units	Approx. Quantities	Unit Prices in Numbers		Bid Amount in Numbers	
				Dollars	Cents	Dollars	Cents
BROUGHT FORWARD:							
603.159	12 Inch Culvert Pipe Option III	LF	250				
603.165	15 Inch Reinforced Concrete Pipe - Class III	LF	2,375				
603.169	15 Inch Culvert Pipe Option III	LF	450				
603.175	18 Inch Reinforced Concrete Pipe - Class III	LF	940				
603.179	18 Inch Culvert Pipe Option III	LF	100				
603.199	24 Inch Culvert Pipe Option III	LF	25				
603.205	30 Inch Reinforced Concrete Pipe - Class III	LF	64				
603.215	36 Inch Reinforced Concrete Pipe - Class III	LF	64				
603.2353	48 Inch Reinforced Concrete Pipe - Class V	LF	200				
603.28	Concrete Collar for Reinforced Concrete Pipe	EA	10				
603.90	12 Inch Ductile Iron Storm Drain	LF	90				
604.09	Catch Basin Type B1	EA	24				
604.0901	Catch Basin Type B1 with Flat Top	EA	48				
CARRIED FORWARD:							

Item No.	Item Description	Units	Approx. Quantities	Unit Prices in Numbers		Bid Amount in Numbers	
				Dollars	Cents	Dollars	Cents
BROUGHT FORWARD:							
604.152	48 Inch Manhole	EA	7				
604.1542	72 Inch Outlet Control Structure	EA	5				
604.1561	96 Inch Doghouse Manhole	EA	1				
604.1581	Inlet Control Structure	EA	1				
604.26	Catch Basin Type B5	EA	13				
605.09	6 Inch Underdrain Type B	LF	1,450				
605.105	8 Inch Underdrain Outlet	LF	350				
605.11	12 Inch Underdrain Type C	LF	1,700				
606.13	31" W-Beam Guardrail – Mid-way Splice	LF	5,050				
606.1724	Bridge Transition - Type III Modified	EA	2				
606.278	Terminal End - Anchored End	EA	11				
606.279	Terminal End - Anchored End, Thrie Beam	EA	2				
606.352	Reflectorized Beam Guardrail Delineator	EA	9				
CARRIED FORWARD:							

Item No.	Item Description	Units	Approx. Quantities	Unit Prices in Numbers		Bid Amount in Numbers	
				Dollars	Cents	Dollars	Cents
BROUGHT FORWARD:							
606.353	Reflectorized Flexible Guardrail Marker	EA	32				
606.356	Underdrain Delineator Post	EA	189				
606.3562	Delineator Post - Remove and Stack	EA	119				
606.3605	Guardrail - Remove, Modify, and Reset, Single Rail	LF	25				
606.3610	Guardrail - Remove, Modify, and Reset Thrie Beam, Single Rail	LF	175				
606.3611	Guardrail - Remove, Modify, and Reset Thrie Beam, Double Rail	LF	700				
606.3631	Guardrail - Remove and Stack or Dispose	LF	10,050				
606.48	Single Galvanized Steel Post	EA	20				
606.64	Gr - Thrie Beam - Dbl Rail	LF	125				
606.65	Gr - Thrie Beam - Sgl Rail	LF	550				
606.754	Widen Shoulder for Energy Absorbing End Terminal	EA	12				
606.791	Guardrail – Flared Terminal – 31” W-Beam Guardrail (7’ Steel Posts, 8” Offset Blocks, Single Faced)	EA	13				
607.093	Right of Way Fencing with Habitat Barrier Fence, Metal Posts	LF	15,000				
CARRIED FORWARD:							

Item No.	Item Description	Units	Approx. Quantities	Unit Prices in Numbers		Bid Amount in Numbers	
				Dollars	Cents	Dollars	Cents
BROUGHT FORWARD:							
607.2325	Pipe Entry Gate	EA	1				
607.4	Chain Link Fence - 3' High	LF	480				
607.41	Post Assembly for Sign or Chain Link Fence	EA	67				
607.4211	Dumpster Enclosure	LS	1				
608.08	Reinforced Concrete Sidewalk/Site Concrete Slabs	SY	340				
608.26	Curb Ramp Detectable Warning Field	SF	75				
609.11	Vertical Curb Type 1	LF	1,700				
609.12	Vertical Curb Type 1 - Circular	LF	350				
609.238	Terminal Curb Type 1 - 8'	EA	8				
610.07	Stone Fill	CY	420				
610.08	Plain Riprap	CY	250				
610.181	Temporary Stone Check Dam	CY	400				
610.182	Permanent Stone Check Dam	CY	80				
CARRIED FORWARD:							

Item No.	Item Description	Units	Approx. Quantities	Unit Prices in Numbers		Bid Amount in Numbers	
				Dollars	Cents	Dollars	Cents
BROUGHT FORWARD:							
613.319	Erosion Control Blanket	SY	40,000				
615.07	Loam	CY	14,050				
618.13	Seeding Method Number 1	UN	850				
618.141	Seeding Method Number 3	UN	200				
619.1201	Mulch	UN	950				
619.1202	Temporary Mulch	LS	1				
619.13	Bark Mulch	CY	60				
620.56	Drainage Geotextile	SY	350				
620.58	Erosion Control Geotextile	SY	14,400				
621.037	Evergreen Tree (5'-6') Group GP A	EA	8				
621.291	Large Deciduous Tree (4" Cal) GP A	EA	1				
621.535	Deciduous Shrub (No. 3 Cont) GP A	EA	25				
625.086	2" Copper Tubing	LF	20				
CARRIED FORWARD:							

Item No.	Item Description	Units	Approx. Quantities	Unit Prices in Numbers		Bid Amount in Numbers	
				Dollars	Cents	Dollars	Cents
BROUGHT FORWARD:							
625.145	8" Non-Metallic Pipe Sleeve	LF	360				
625.16	2" Non-Metallic Pipe	LF	780				
626.111	Barrier Junction Box	EA	13				
626.113	4'x4' Splice Box	EA	12				
626.12	Quazite Junction Box (36x24)	EA	81				
626.13	Primary Electric Manholes (CMP)	EA	6				
626.22	Non-Metallic Conduit	LF	22,755				
626.2214	4" Non-Metallic Conduit, Concrete Encased	LF	6,500				
626.2215	5" Non-Metallic Conduit, Concrete Encased	LF	6,500				
626.3321	36-inch Diameter Drilled Shaft	LF	360				
626.3322	30-Inch Diameter Drilled Shaft - Rock Socket	LF	80				
626.341	Light Standard Foundation	EA	65				
627.18	12" Solid White Pavement Marking	LF	10,200				
CARRIED FORWARD:							

Item No.	Item Description	Units	Approx. Quantities	Unit Prices in Numbers		Bid Amount in Numbers	
				Dollars	Cents	Dollars	Cents
BROUGHT FORWARD:							
627.4072	Pref Pave Mark Tape Line, Groove Install	SF	2,000				
627.681	Temporary 6 Inch Painted Pavement Marking Line -Yellow or White	LF	140,000				
627.71	4" White Pavement Marking Line	LF	1,100				
627.731	Temporary 6 Inch Black Pavement Marking Tape	LF	2,000				
627.744	6" White or Yellow Painted Pavement Marking Line	LF	50,700				
627.75	White or Yellow Pavement & Curb Marking	SF	200				
627.77	Remove Existing Pavement Marking	SF	3,400				
627.73	Temporary 6 Inch Pavement Marking Tape	LF	3,200				
627.812	Temporary Raised Pavement Markers	EA	530				
627.9011	Pavement Marking Symbol	EA	9				
627.94	Pavement Marking Tape	LF	2,750				
629.05	Hand Labor, Straight Time	HR	20				
631.10	Air Compressor (Inc Operator)	HR	20				
CARRIED FORWARD:							

Item No.	Item Description	Units	Approx. Quantities	Unit Prices in Numbers		Bid Amount in Numbers	
				Dollars	Cents	Dollars	Cents
BROUGHT FORWARD:							
631.11	Air Tool (Inc Operator)	HR	20				
631.115	Jackhammer (Inc Operator)	HR	20				
631.12	All Purpose Excavator (Inc Operator)	HR	20				
631.171	Truck - Small (Including Operator)	HR	20				
631.18	Chain Saw Rental (Inc Operator)	HR	20				
631.32	Culvert Cleaner (Inc Operator)	HR	20				
631.36	Foreperson	HR	25				
631.51	Bucket Truck	HR	20				
631.52	Scissor Lift	HR	20				
631.53	Electrician	HR	20				
631.54	Electrician's Apprentice	HR	20				
633.021	Propane Service Line	LF	100				
634.16	Highway Lighting	LS	1				
CARRIED FORWARD:							

Item No.	Item Description	Units	Approx. Quantities	Unit Prices in Numbers		Bid Amount in Numbers	
				Dollars	Cents	Dollars	Cents
BROUGHT FORWARD:							
634.2042	LED Luminaries	EA	5				
634.210	Conventional Light Standard	EA	5				
639.18	Field Office Type A	EA	1				
639.19	Field Office Type B	EA	1				
641.35	Aluminum Flag Pole	EA	1				
643.63	Flashing Beacon - Solar Powered	EA	4				
643.712	Lane Use Signal	EA	9				
645.105	Remove and Stack Sign	EA	13				
645.1051	Remove and Stack Ground Mount Guide Sign and Structure	EA	4				
645.109	Remove and Reset Sign	EA	3				
645.1092	Canopy Mounted Dynamic Message Sign	EA	1				
645.121	Overhead Guide Sign 1 (Sta. 281+45)	LS	1				
645.122	Overhead Guide Sign 2 (Sta.306+65)	LS	1				
CARRIED FORWARD:							

Item No.	Item Description	Units	Approx. Quantities	Unit Prices in Numbers		Bid Amount in Numbers	
				Dollars	Cents	Dollars	Cents
BROUGHT FORWARD:							
645.123	Overhead Guide Sign 3 (Sta.318+81)	LS	1				
645.124	Overhead Guide Sign 4 (Sta.332+00)	LS	1				
645.125	Overhead Guide Sign 5 (Sta.359+50)	LS	1				
645.126	Overhead Guide Sign 6 (Sta.374+50)	LS	1				
645.127	Overhead Guide Sign 7 (Sta.382+50)	LS	1				
645.128	Overhead Guide Sign 8 (Sta.414+90)	LS	1				
645.14	Canopy Mounted Sign	EA	7				
645.141	Canopy Mounted DMS Remove and Reset	EA	1				
645.155	Variable Speed Limit Sign	EA	2				
645.251	Roadside Guide Signs, Type I	SF	1,462				
645.271	Regulatory, Warning, Confirmation and Route Assembly Sign, Type I	SF	490				
645.28	Wood Post	EA	26				
645.289	Steel H-Beam Poles	LB	13,400				
CARRIED FORWARD:							

Item No.	Item Description	Units	Approx. Quantities	Unit Prices in Numbers		Bid Amount in Numbers	
				Dollars	Cents	Dollars	Cents
BROUGHT FORWARD:							
645.501	Remove and Reset Mainline Sign 1	LS	1				
645.502	Remove and Reset Mainline Sign 2	LS	1				
645.503	Remove and Reset Mainline Sign 3	LS	1				
652.30	Flashing Arrow Board	EA	6				
652.312	Type III Barricade	EA	10				
652.33	Drum	EA	400				
652.34	Cone	EA	200				
652.35	Construction Signs	SF	1,450				
652.36	Maintenance of Traffic Control Devices	LS	1				
652.38	Flagger	HR	880				
652.41	Portable-Changeable Message Sign	EA	5				
652.45	Truck Mounted Attenuator	CD	500				
652.451	Automated Trailer Mounted Speed Limit Sign	EA	2				
CARRIED FORWARD:							

Item No.	Item Description	Units	Approx. Quantities	Unit Prices in Numbers		Bid Amount in Numbers	
				Dollars	Cents	Dollars	Cents
BROUGHT FORWARD:							
652.50	Temporary Barrier	LS	1				
655.01	Installation of ORT Lane Controller Cabinet	EA	2				
655.012	Installation of Cash Lane Controller Cabinet	EA	9				
655.02	DVAS Mount Installation	EA	13				
655.03	VCARS Mount Installation	EA	20				
655.04	Installation of Sensor Loops	LS	1				
655.05	Installation of AVI Antennas	EA	27				
655.06	Installation of AVI Readers	EA	6				
655.07	Traffic Control Pedestal Preparation Work	EA	9				
655.08	OPUS Mount Installation	EA	30				
655.09	Armored Cable - 10/3	LF	100				
655.100	#2/0 AWG Wire	LF	1,550				
655.1001	#1/0 AWG Wire	LF	1,000				
CARRIED FORWARD:							

Item No.	Item Description	Units	Approx. Quantities	Unit Prices in Numbers		Bid Amount in Numbers	
				Dollars	Cents	Dollars	Cents
BROUGHT FORWARD:							
655.1003	#3/0 AWG Wire	LF	3,500				
655.101	#1 AWG Wire	LF	5,000				
655.102	#2 AWG Wire	LF	1,150				
655.104	#4 AWG Wire	LF	100				
655.106	#6 AWG Wire	LF	100				
655.11	#10 AWG Wire	LF	4,850				
655.12	#12 AWG Wire	LF	80,000				
655.13	#14 AWG Wire	LF	1,000				
655.14	4pr/24 (Category 5e) Cable	LF	44,000				
655.15	LMR 400 Cable	LF	1,730				
655.16	Fiber Optic Cable – 6 Fiber	LF	3,390				
655.17	IVIS Homerun Loop Cable (IMSA 50-2 #14)	LF	11,350				
655.200	1 1/2" Schedule 40 PVC Conduit	LF	250				
CARRIED FORWARD:							

Item No.	Item Description	Units	Approx. Quantities	Unit Prices in Numbers		Bid Amount in Numbers	
				Dollars	Cents	Dollars	Cents
BROUGHT FORWARD:							
655.2001	3/4" Schedule 40 PVC Conduit	LF	200				
655.2002	1" Schedule 40 PVC Conduit	LF	200				
655.2003	2" Schedule 40 PVC Conduit	LF	400				
655.201	3" Schedule 40 PVC Conduit	LF	200				
655.202	4" Schedule 40 PVC Conduit	LF	750				
655.2021	1" Schedule 80 PVC Conduit	LF	400				
655.203	1 1/2" Schedule 80 PVC Conduit	LF	1,440				
655.2031	2" Schedule 80 PVC Conduit	LF	430				
655.204	3" Schedule 80 PVC Conduit	LF	3,000				
655.205	4" Schedule 80 PVC Conduit	LF	230				
655.2051	6" Schedule 80 PVC Conduit	LF	300				
655.2052	5" Schedule 80 PVC Conduit	LF	300				
655.206	1" Galvanized Rigid Metal Conduit	LF	900				
CARRIED FORWARD:							

Item No.	Item Description	Units	Approx. Quantities	Unit Prices in Numbers		Bid Amount in Numbers	
				Dollars	Cents	Dollars	Cents
BROUGHT FORWARD:							
655.2061	3/4" Galvanized Rigid Metal Conduit	LF	600				
655.207	1 1/2" Galvanized Rigid Metal Conduit	LF	350				
655.2071	2" Galvanized Rigid Metal Conduit	LF	600				
655.208	3" Galvanized Rigid Metal Conduit	LF	1,040				
655.209	1/2" Liquid Tight Metallic Flexible Conduit	LF	700				
655.210	3/4" Liquid Tight Metallic Flexible Conduit	LF	280				
655.2101	1 1/2" Liquid Tight Metallic Flexible Conduit	LF	100				
655.2102	2" Liquid Tight Metallic Flexible Conduit	LF	100				
655.2103	1" Liquid Tight Metallic Flexible Conduit	LF	100				
655.211	1 1/2" Electrical Metallic Tubing Conduit	LF	180				
655.2111	1" Electrical Metallic Tubing Conduit	LF	180				
655.212	2" Electrical Metallic Tubing Conduit	LF	180				
655.213	3" Electrical Metallic Tubing Conduit	LF	100				
CARRIED FORWARD:							

Item No.	Item Description	Units	Approx. Quantities	Unit Prices in Numbers		Bid Amount in Numbers	
				Dollars	Cents	Dollars	Cents
BROUGHT FORWARD:							
655.214	4" Electrical Metallic Tubing Conduit	LF	100				
655.215	3/4" Electrical Metallic Tubing Conduit	LF	100				
655.221	Type A Pull Box Inside	EA	36				
655.222	Type C Pull Box in Tunnel/Booth Pit	EA	40				
655.223	Type D Pull Box Outdoor Canopy	EA	4				
655.224	Type E Pull Box Steel in Booth	EA	18				
655.225	Type F Pull Box Outside	EA	13				
655.30	12" x 12" x 6" Galvanized Junction Box	EA	100				
655.31	18" x 18" x 6" Galvanized Junction Box	EA	8				
655.40	18" x 24" x 12" Junction Box	EA	6				
655.42	36" x 30" x 20" NEMA 4X Cabinet	EA	6				
655.43	60 AMP 3 Phase Panelboard Cabinet	EA	4				
655.44	100 AMP 3 Phase Panelboard Cabinets	EA	4				
CARRIED FORWARD:							

Item No.	Item Description	Units	Approx. Quantities	Unit Prices in Numbers		Bid Amount in Numbers	
				Dollars	Cents	Dollars	Cents
BROUGHT FORWARD:							
655.50	2" PVC Conduit Condulets	EA	20				
655.51	4" PVC Conduit Condulets	EA	20				
655.511	3/4" Rigid Metal Conduit Condulets	EA	10				
655.52	1" Rigid Metal Conduit Condulets	EA	50				
655.53	1½" Rigid Metal Conduit Condulets	EA	50				
655.54	2" Rigid Metal Conduit Condulets	EA	20				
655.55	3" Electrical Metal Tubing Condulets	EA	20				
655.56	2" Electrical Metal Tubing Condulets	EA	20				
655.57	1 1/2" Electrical Metal Tubing Condulets	EA	20				
655.58	3/4" Electrical Metal Tubing Condulets	EA	20				
655.59	1" Electrical Metal Tubing Condulets	EA	20				
655.63	4-inch x 4-inch PVC NEMA 3R Wireway	LF	630				
655.64	6-inch x 6-inch PVC NEMA 3R Wireway	LF	660				
CARRIED FORWARD:							

Item No.	Item Description	Units	Approx. Quantities	Unit Prices in Numbers		Bid Amount in Numbers	
				Dollars	Cents	Dollars	Cents
BROUGHT FORWARD:							
655.65	8-inch x 8-inch PVC NEMA 3R Wireway	LF	660				
655.66	12-inch x 12-inch PVC NEMA 3R Wireway	LF	400				
655.75	Concrete Encased Conduit	CY	60				
655.80	Lightning Suppression System	LS	1				
655.81	Key Switch	EA	18				
655.82	Duplex Receptacle	EA	20				
655.83	NEMA L5-30R Receptacle	EA	6				
655.84	Quadplex Receptacle	EA	30				
655.90	Space Frame Lighting	LS	1				
655.92	LED Canopy Light Fixture	EA	18				
655.98	Toll Booth Electrical Installation	LS	1				
655.99	LED Bumper Beacon	EA	9				
656.50	Baled Hay, In Place	EA	50				
CARRIED FORWARD:							

Item No.	Item Description	Units	Approx. Quantities	Unit Prices in Numbers		Bid Amount in Numbers	
				Dollars	Cents	Dollars	Cents
BROUGHT FORWARD:							
656.60	Temporary Berms	LF	150				
656.62	Temporary Slope Drains	LF	150				
656.632	30" Temporary Silt Fence	LF	24,000				
659.10	Mobilization	LS	1				
665.002	Communications	LS	1				
800.01	Toll Administration Building	LS	1				
800.22	HVAC Tunnel and Booths	LS	1				
800.23	Tunnel and Toll Stairway Lighting, Fire Alarm, and House Power	LS	1				
800.24	Toll Administration Building Standby Generator	LS	1				
800.40	Tunnel Stair Enclosures	LS	1				
800.41	Tunnel Access Hatch	LS	1				
800.501	Southbound and Northbound Plaza Canopies	LS	1				
800.503	Metal Stairs at Tunnel Staircases	LS	1				
CARRIED FORWARD:							

Item No.	Item Description	Units	Approx. Quantities	Unit Prices in Numbers		Bid Amount in Numbers	
				Dollars	Cents	Dollars	Cents
BROUGHT FORWARD:							
800.51	New Toll Booth Installation	LS	1				
800.62	Radon Mitigation System	LS	1				
801.03	Test Pits	EA	2				
801.132	2 Inch Force Main	LF	50				
801.141	4" PVC Sanitary Sewer (SDR-35)	LF	40				
802.23	Subsurface Wasterwater Leach Field With Geotextile Sand Filter (GSF)	LS	1				
802.241	1250 Gallon Precast Septic Tank with Pump	LS	1				
822.37	16" Ductile Iron Pipe	LF	1,660				
822.60	Water Meter Pit	LS	1				
823.3411	1" Air Release Valve	EA	1				
823.374	16" Gate Valve	EA	2				
832.41	Type A Steel Site Bollard	EA	9				
TOTAL:							

Acknowledgment is hereby made of the following Addenda received since issuance of the Plans and Specifications: _____

Accompanying this Proposal is an original bid bond, cashiers or certified check on _____ Bank, for _____, payable to the Maine Turnpike Authority. In case this Proposal shall be accepted by the Maine Turnpike Authority and the undersigned should fail to execute a Contract with, and furnish the security required by the Maine Turnpike Authority as set forth in the Specifications, within the time fixed therein, an amount of money equal to Five (5%) Percent of the Total Amount of the Proposal for the Contract awarded to the undersigned, but not less than \$500.00, obtained out of the original bid bond, cashier's or certified check, shall become the property of the Maine Turnpike Authority; otherwise the check will be returned to the undersigned.

The performance of said Work under this Contract will be completed during the time specified in Subsection 107.1.

It is agreed that time is of the essence of this Contract and that I (we) will, in the event of my (our) failure to complete the Work within the time limit named above, pay to Maine Turnpike Authority liquidated damages in the amount or amounts stated in the Specifications.

The undersigned is an Individual/Partnership/Corporation under the laws of the State of _____, having principal office at _____, thereunto duly authorized.

_____ (SEAL)

_____ (SEAL)

Affix Corporate Seal
or Power of Attorney
Where Applicable

_____ (SEAL)

By: _____

Its: _____

Information below to be typed or printed where applicable:

INDIVIDUAL:

_____	_____
(Name)	(Address)

PARTNERSHIP - Name and Address of General Partners:

_____	_____
(Name)	(Address)

_____	_____
(Name)	(Address)

_____	_____
(Name)	(Address)

_____	_____
(Name)	(Address)

INCORPORATED COMPANY:

_____	_____
(President)	(Address)

_____	_____
(Vice President)	(Address)

_____	_____
(Secretary)	(Address)

_____	_____
(Treasurer)	(Address)

MAINE TURNPIKE AUTHORITY
CONTRACT AGREEMENT
CONTRACT 2018.20
YORK TOLL PLAZA
MILE 8.8

This Agreement made and entered into between the Maine Turnpike Authority, and sometimes termed the “Authority”, and _____
_____ herein termed the “Contractor”:

WITNESSETH: That the Authority and the Contractor, in consideration of the premises and of the mutual covenants, considerations and agreements herein contained, agree as follows:

FIRST: The parties hereto mutually agree that the documents attached hereto and herein incorporated and made a part hereof collectively evidencing and constituting the entire Contract to the same extent as if herein written in full, are the Notice to Contractors, the Accepted Proposal, the Specifications, the Plans, this Agreement, the Contract Bond and all Addenda to the Contract Documents duly issued and herewith enumerated:

SECOND: The Contractor for and in consideration of certain payments to be made as hereafter specified, hereby covenants and agrees to perform and execute all of the provisions of this Contract and of all documents and parts attached hereto and made a part thereof, and at his own cost and expense to furnish and perform everything necessary and required to construct and complete, ready for its intended purpose, in accordance with the Contract and such instructions as the Engineer may give, acceptable to the Authority, in the times provided, all of the Work covered and included under Contract No. _____ covering _____ as herein described.

THIRD: In consideration of the performance by the Contractor of his covenants and agreements as herein set forth, the Authority hereby covenants and agrees to pay the Contractor according to the Schedule of Prices set forth in the Proposal with additions and deductions as elsewhere herein provided in the times and in the manner stated in the Specifications. This Agreement shall insure to the benefit of, and shall be binding upon the parties hereto, and upon their respective successors and assigns; but neither party hereto shall assign or transfer his interest herein in whole or in part without the consent of the other, except as herein provided.

IN WITNESS WHEREOF the parties to this Agreement have executed the same in quintuplicate.

AUTHORITY -

MAINE TURNPIKE AUTHORITY

By: _____

Title: CHAIRMAN

Date of Signature: _____

ATTEST:

Secretary

CONTRACTOR -

CONTRACTOR

By: _____

Title: _____

Date of Signature: _____

WITNESS:

MAINE TURNPIKE AUTHORITY
CONTRACT BOND
CONTRACT 2018.20
YORK TOLL PLAZA
MILE 8.8

KNOW ALL MEN BY THESE PRESENTS that _____
of _____ in the County of _____ and State of _____
as Principal, and _____ a Corporation duly organized under
the laws of the State of _____ and having a usual place of business in _____

As Surety, are held and firmly bound unto the Maine Turnpike Authority in the sum of _____ Dollars (\$ _____),
to be paid to said Maine Turnpike Authority, or its successors, for which payment, well and truly
to be made, we bind ourselves, our heirs, executors, successors and assigns jointly and severally
by these presents.

The condition of this obligation is such that the Principal, designated as Contractor in the
foregoing Contract No. _____, shall faithfully perform the Contract on his part and
satisfy all claims and demands incurred for the same and shall pay all bills for labor, material,
equipment and all other items contracted for, or used by him, in connection with the Work
contemplated by said Contract, and shall fully reimburse the Oblige for all outlay and expense
which the Oblige may incur in making good any default of said Principal, then this Obligation
shall be null and void; otherwise it shall remain in full force and effect.

Signed and sealed this _____ day of _____, A.D., 201__

Witnesses:

CONTRACTOR

_____ (SEAL)
_____ (SEAL)
_____ (SEAL)

SURETY

_____ (SEAL)
_____ (SEAL)
_____ (SEAL)

(Surety must attach copy of Power of Attorney showing authority of Office or Agent to execute bonds)

MAINE TURNPIKE AUTHORITY
FINAL LIEN AND CLAIM WAIVER AND AFFIDAVIT
CONTRACT 2018.20
YORK TOLL PLAZA
MILE 8.8

Upon receipt of the sum of _____, which sum represents the total amount paid, including the current payment for work done and materials supplied for Project No. _____, in _____, Maine, under the undersigned's Contract with the Maine Turnpike Authority.

The undersigned, on oath, states that the Final Payment of _____ is the final payment for all work, labor, materials, services and miscellaneous (all of which are hereinafter referred to as "Work Items") supplied to the said Project through _____ and that no additional sum is claimed by the undersigned respecting said Project.

The undersigned, on oath, states that all persons and firms who supplied Work Items to the undersigned in connection with said Project have been fully paid by the undersigned for such Work Items or that such payment will be fully effected immediately upon receipt of this payment.

In consideration of the payment herewith made, the undersigned does fully and finally release and hold harmless the Maine Turnpike Authority, and its Surety, if any, from any and all claims, liens or right to claim or lien, arising out of this Project under any applicable bond, law or statute.

It is understood that this Affidavit is submitted to assure the Owner and others that all liens and claims relating to the Work Items furnished by the undersigned are paid.

(Contractor)

By: _____
Title: _____

State of MAINE
County of _____

I, _____, hereby certify on behalf of _____
(Company Officer) (Company Name)
its _____, being first duly sworn and stated that the foregoing representations are
(Title)
are true and correct upon his own knowledge and that the foregoing is his free act and deed in said capacity and the free act and deed of the above-named _____.
(Company Name)

The above-named, _____, personally appeared before me this ____ day of _____ and swears that this is his free act and deed.

(SEAL)

Notary Public:
My Commission Expires: _____

MAINE TURNPIKE AUTHORITY

PART I – SUPPLEMENTAL SPECIFICATIONS

CONTRACT 2018.20

YORK TOLL PLAZA
MILE 8.8

The Supplemental Specifications are not included in these
Contract Documents but are available at
[Maine Turnpike.com](http://MaineTurnpike.com) for download.

(This page left intentionally blank)

MAINE TURNPIKE AUTHORITY
MAINE TURNPIKE

PART II – SPECIAL PROVISIONS

CONTRACT 2018.20

YORK TOLL PLAZA
MILE 8.8

TABLE OF CONTENTS

PART II – SPECIAL PROVISIONS	SP - 2
General Description of Work.....	SP - 2
Plans	SP - 2
101.2 Definition.....	SP - 2
Holidays	SP - 2
103.3.3.1 Prequalification Requirement for Award	SP - 3
103.4 Notice of Award.....	SP - 3
104.2.2 Furnishing of Permits	SP - 3
104.3.4 Workers and Equipment.....	SP - 4
104.3.8 Wage Rates and Labor Laws	SP - 4
104.4.6 Utility Coordination	SP - 8
104.4.7 Cooperation with Other Contractors.....	SP - 10
105.2.7 Use of Explosives	SP - 10
105.8.2 Permit Requirements.....	SP - 17
107.1 Contract Time and Contract Completion Date	SP - 19
107.4.2 Schedule of Work Required	SP - 19
107.4.6 Prosecution of Work	SP - 19
107.4.7 Limitations of Operations.....	SP – 23
110.1 Indemnification.....	SP - 25
110.3.9 Administration & General Provisions.....	SP - 26

MAINE TURNPIKE AUTHORITYSPECIFICATIONSPART II – SPECIAL PROVISIONS

All work shall be governed by the Maine Department of Transportation Standard Specifications, Revision of November 2014, except for that work which applies to sections of the Maine Department of Transportation Standard Specifications which are amended by the Maine Turnpike Supplemental Specifications and the following modifications, additions and deletions.

General Description of Work

The Project consists of highway, structures, building and site work required to construct a new toll facility. The work at Mile 8.8 consists of constructing six (6) open, high-speed (70 mph) E-ZPass center lanes (3 in each direction) with overhead open frame gantries with electronic toll collection equipment, nine (9) cash lanes with toll booths (4 northbound and 5 southbound) with canopies, reconstruction of mainline to accommodate approach and departure lanes at the new toll plaza, construction of a precast pedestrian tunnel for employee access and utilities, driveway from Chases Pond Road, parking lot and Administration Building.

The work includes earthwork, pavement, concrete, signing, overhead sign structures, concrete barrier, guardrail, mechanical work, electrical work, lighting and lightning suppression systems. The work also includes the installation of tolling equipment in the tunnel, canopy, and toll booth, maintenance of traffic and all other work incidental thereto in accordance with the Plans and Specifications.

The general limits of work are from Mile 7.9 (Station 295+00) to Mile 9.6 (Station 386+08) in York.

Plans

The drawings included in these Contract Documents, and referred to as the Plans, show the general character of the work to be done under this Contract. They bear the general title “Maine Turnpike – Contract 2018.20 – York Toll Plaza Mile 7.9 to Mile 9.6”. The right is reserved by the Resident to make such minor corrections or alterations in the Plans as he deems necessary without change in the unit prices on the Schedule of Prices of the Proposal.

101.2 DefinitionHolidays

The following is added after Memorial Day in the Supplemental Specifications:

Christmas Day 2018	12:01 p.m. (Noon) preceding Monday to 6:00 a.m. the following Wednesday
New Year’s Day 2019	12:01 p.m. (Noon) preceding Monday to

	6:00 a.m. the following Wednesday
Independence Day 2019 (Fourth of July)	12:01 a.m. (Midnight) preceding Wednesday to 6:00 a.m. the following Friday
Christmas Day 2019	12:01 p.m. (Noon) preceding Tuesday to 6:00 a.m. the following Thursday
New Year's Day 2020	12:01 p.m. (Noon) preceding Tuesday to 6:00 a.m. the following Thursday
Independence Day 2020 (Fourth of July)	12:01 a.m. (Midnight) preceding Friday to 6:00 a.m. the following Monday
Christmas Day 2020	12:01 p.m. (Noon) preceding Thursday to 6:00 a.m. the following Monday
New Year's Day 2021	12:01 p.m. (Noon) preceding Thursday to 6:00 a.m. the following Monday
Independence Day 2021 (Fourth of July)	12:01 a.m. (Midnight) preceding Friday to 6:00 a.m. the following Tuesday

103.3.3.1 Prequalification Requirement for Award

This Subsection of the Supplemental Specification is deleted and replaced with:

103.3.3.1 Prequalification Requirement for Award - As outlined in the Notice to Contractors Post-Bid Qualification will not be permitted for this project. Bids will only be accepted from contractors Pre-Qualified as outlined in the Notice to Contractors.

103.4 Notice of Award

The following sentence is added:

The Maine Turnpike Authority Board is scheduled to consider the Contract Award on October 18, 2018.

104.2.2 Furnishing of Permits

The Contractor shall obtain the following permits:

State Electrical and State Plumbing permits.

The Contractor will not obtain permits from the Town of York.

104.3.4 Workers and Equipment

This Subsection is amended by the addition of the following paragraph:

The Contractor shall provide a competent, English-speaking Project Manager experienced in the type of Work being performed that will be responsible for the daily management of the York Toll Plaza Project. Two weeks prior to the preconstruction meeting the Contractor shall submit a detailed resume of the proposed Project Manager for MTA approval. The Project manager shall have significant experience managing and completing projects on schedule which had contract values in excess of \$10 million. In addition, the project manager shall have significant experience managing and scheduling sub-contractors. If MTA does not approve the submitted Project Manager the contractor shall proposing another Project Manager until an acceptable Project Manager to the MTA has been submitted. Substitution of the project manager will not be allowed without written permission from the MTA. The Project Manager shall have full authority to manage the Work in accordance with the Contract and will be responsible for managing the work of the Contractor's employees and all Subcontractor's present. The Project Manager and the Project Superintendent shall not be the same person. Such Project Manager must be provided regardless of the amount of Work being done.

104.3.8 Wage Rates and Labor Laws

Section 104.3.8 Wage Rates and Labor Laws has been amended as follows:

The fair minimum hourly rates determined by the State of Maine Department of Labor for this Contract are as follows:

THIS DOCUMENT MUST BE CLEARLY POSTED AT THE PERTAINING STATE FUNDED PREVAILING WAGE CONSTRUCTION SITE

**State of Maine
 Department of Labor
 Bureau of Labor Standards
 Augusta, Maine 04333-0045
 Telephone (207) 623-7906**

Wage Determination - In accordance with 26 MRSA §1301 et. seq., this is a determination by the Bureau of Labor Standards, of the fair minimum wage rate to be paid to laborers and workers employed on the below titled project.

Title of Project -----2018.20-York Toll Plaza Replacement, MM8.8

Location of Project -York, York County

**2018 Fair Minimum Wage Rates
 Highway & Earth York County-Revised-**

<u>Occupation Title</u>	<u>Minimum Wage</u>	<u>Minimum Benefit</u>	<u>Total</u>	<u>Occupation Title</u>	<u>Minimum Wage</u>	<u>Minimum Benefit</u>	<u>Total</u>
Asphalt Raker	\$16.00	\$0.44	\$16.44	Ironworker -- Ornamental	\$23.13	\$4.80	\$27.93
Backhoe Loader Operator	\$20.00	\$2.23	\$22.23	Ironworker - Reinforcing	\$24.79	\$10.60	\$35.39
Boom Truck (Truck Crane) Operator	\$21.66	\$6.86	\$28.52	Ironworker - Structural	\$21.80	\$4.88	\$26.68
Bulldozer Operator	\$22.00	\$4.17	\$26.17	Laborer (Includes Helper-Tender)	\$14.50	\$0.94	\$15.44
Carpenter	\$21.00	\$2.36	\$23.36	Laborer - Skilled	\$17.00	\$2.24	\$19.24
Cement Mason/Finisher	\$17.00	\$0.56	\$17.56	Line Erector-Power/Cable Splicer	\$26.00	\$7.59	\$33.59
Crane Operator => 15 Tons)	\$26.00	\$5.97	\$31.97	Loader Operator - Front-End	\$19.25	\$3.37	\$22.62
Crusher Plant Operator	\$17.50	\$2.01	\$19.51	Mechanic- Maintenance	\$21.00	\$3.15	\$24.15
Diver	\$28.50	\$1.48	\$29.98	Painter	\$17.00	\$0.00	\$17.00
Driller -Rock	\$18.38	\$2.60	\$20.98	Paver Operator	\$18.38	\$1.73	\$20.11
Earth Auger Operator	\$22.97	\$6.17	\$29.14	Pipelayer	\$18.00	\$3.16	\$21.16
Electrician - Licensed	\$26.00	\$4.67	\$30.67	Pump Installer	\$21.00	\$3.73	\$24.73
Electrician Helper/Cable Puller (Licensed)	\$17.00	\$2.84	\$19.84	Reclaimer Operator	\$19.13	\$2.98	\$22.11
Elevator Constructor/Installer	\$19.25	\$1.62	\$20.87	Roller Operator - Earth	\$16.00	\$1.89	\$17.89
Excavator Operator	\$21.13	\$3.36	\$24.49	Roller Operator - Pavement	\$18.03	\$2.19	\$20.22
Fence Setter	\$17.25	\$1.72	\$18.97	Screed/Wheelman	\$18.60	\$3.68	\$22.28
Flagger	\$12.00	\$0.00	\$12.00	Truck Driver - Light	\$17.83	\$3.74	\$21.57
Grader/Scraper Operator	\$21.33	\$5.65	\$26.98	Truck Driver - Medium	\$18.00	\$1.89	\$19.89
Highway Worker/Guardrail Installer	\$16.50	\$0.79	\$17.29	Truck Driver - Heavy	\$16.38	\$1.61	\$17.99
Hot Top Plant Operator	\$23.00	\$3.90	\$26.90	Truck Driver - Tractor Trailer	\$19.00	\$3.18	\$22.18

The Laborer classifications include a wide range of work duties. Therefore, if any specific occupation to be employed on this project is not listed in this determination, call the Bureau of Labor Standards at the above number for further clarification.

Welders are classified in the trade to which the welding is incidental.

Apprentices - The minimum wage rate for registered apprentices are those set forth in the standards and policies of the Maine State Apprenticeship and Training Council for approved apprenticeship programs.

Posting of Schedule - Posting of this schedule is required in accordance with 26 MRSA §1301 et. seq., by any contractor holding a State contract for construction valued at \$50,000 or more and any subcontractors to such a contractor.

Appeal - Any person affected by the determination of these rates may appeal to the Commissioner of Labor by filing a written notice with the Commissioner stating the specific grounds of the objection within ten (10) days from the filing of these rates.

Determination No: HI-138-2018

A true copy

Filing Date: July 13, 2018

Attest: 

Expiration Date: 12-31-2018

Scott A. Cotnoir
 Wage & Hour Director

BLS(Highway & Earth York)

THIS DOCUMENT MUST BE CLEARLY POSTED AT THE PERTAINING STATE FUNDED PREVAILING WAGE CONSTRUCTION SITE

State of Maine
 Department of Labor
 Bureau of Labor Standards
 Augusta, Maine 04333-0045
 Telephone (207) 623-7906

Wage Determination - In accordance with 26 MRSA §1301 et. seq., this is a determination by the Bureau of Labor Standards, of the fair minimum wage rate to be paid to laborers and workers employed on the below titled project.

Title of Project -----2018.20-York Toll Plaza Replacement, MM8.8

Location of Project -York, York County

**2018 Fair Minimum Wage Rates
 Heavy & Bridge York County**

<u>Occupation Title</u>	<u>Minimum Wage</u>	<u>Minimum Benefit</u>	<u>Total</u>	<u>Occupation Title</u>	<u>Minimum Wage</u>	<u>Minimum Benefit</u>	<u>Total</u>
Backhoe Loader Operator	\$20.00	\$2.16	\$22.16	Laborer (Includes Helper-Tender)	\$16.50	\$1.63	\$18.13
Boom Truck (Truck Crane) Operator	\$21.66	\$6.86	\$28.52	Laborer - Skilled	\$21.00	\$4.15	\$25.15
Bricklayer	\$24.00	\$3.99	\$27.99	Line Erector-Power/Cable Splicer	\$25.75	\$7.36	\$33.11
Bulldozer Operator	\$20.00	\$4.06	\$24.06	Loader Operator - Front-End	\$21.00	\$3.21	\$24.21
Carpenter	\$24.31	\$10.58	\$34.89	Mechanic- Maintenance	\$20.00	\$5.72	\$25.72
Carpenter - Rough	\$20.94	\$4.46	\$25.40	Mechanic- Refrigeration	\$24.88	\$4.76	\$29.64
Cement Mason/Finisher	\$17.00	\$0.56	\$17.56	Millwright	\$29.90	\$23.69	\$53.59
Communication Equipment Installer	\$20.00	\$1.85	\$21.85	Painter	\$22.00	\$3.06	\$25.06
Comm Transmission Erector Microwave & Cell	\$19.00	\$3.57	\$22.57	Paver Operator	\$20.00	\$3.78	\$23.78
Crane Operator => 15 Tons)	\$29.00	\$10.84	\$39.84	Pile Driver Operator	\$25.00	\$11.13	\$36.13
Crusher Plant Operator	\$17.75	\$2.48	\$20.23	Pipe/Steam/Sprinkler Fitter	\$22.25	\$8.62	\$30.87
Diver	\$32.00	\$0.00	\$32.00	Pipelayer	\$28.00	\$12.54	\$40.54
Driller -Rock	\$18.38	\$2.60	\$20.98	Pump Installer	\$21.00	\$3.73	\$24.73
Earth Auger Operator	\$23.76	\$6.31	\$30.07	Reclaimer Operator	\$18.50	\$2.85	\$21.35
Electrician - Licensed	\$30.07	\$17.09	\$47.16	Rigger	\$20.00	\$6.12	\$26.12
Electrician Helper/Cable Puller (Licensed)	\$27.00	\$12.01	\$39.01	Roller Operator - Earth	\$15.88	\$1.76	\$17.64
Excavator Operator	\$23.25	\$3.71	\$26.96	Roller Operator - Pavement	\$18.30	\$1.64	\$19.94
Fence Setter	\$16.00	\$1.17	\$17.17	Truck Driver - Light	\$18.15	\$2.88	\$21.03
Flagger	\$12.00	\$0.00	\$12.00	Truck Driver - Medium	\$17.75	\$1.82	\$19.57
Grader/Scraper Operator	\$21.33	\$5.13	\$26.46	Truck Driver - Heavy	\$19.00	\$3.19	\$22.19
HVAC (Heat-Vent-Air Conditioning)	\$23.00	\$3.05	\$26.05	Truck Driver - Tractor Trailer	\$20.50	\$5.46	\$25.96
Ironworker - Ornamental	\$22.48	\$4.85	\$27.70				
Ironworker - Reinforcing	\$26.20	\$12.15	\$38.35				
Ironworker - Structural	\$23.00	\$6.26	\$29.26				

The Laborer classifications include a wide range of work duties. Therefore, if any specific occupation to be employed on this project is not listed in this determination, call the Bureau of Labor Standards at the above number for further clarification.

Welders are classified in the trade to which the welding is incidental.

Apprentices - The minimum wage rate for registered apprentices are those set forth in the standards and policies of the Maine State Apprenticeship and Training Council for approved apprenticeship programs.

Posting of Schedule - Posting of this schedule is required in accordance with 26 MRSA §1301 et. seq., by any contractor holding a State contract for construction valued at \$50,000 or more and any subcontractors to such a contractor.

Appeal - Any person affected by the determination of these rates may appeal to the Commissioner of Labor by filing a written notice with the Commissioner stating the specific grounds of the objection within ten (10) days from the filing of these rates.

Determination No: HB-045-2018

A true copy

Filing Date: July 13, 2018

Attest: Scott A. Cotnoir

Expiration Date: 12-31-2018

Scott A. Cotnoir
 Wage & Hour Director

BLS(Heavy & Bridge York)

THIS DOCUMENT MUST BE CLEARLY POSTED AT THE PERTAINING STATE FUNDED PREVAILING WAGE CONSTRUCTION SITE

**State of Maine
Department of Labor
Bureau of Labor Standards
Augusta, Maine 04333-0045
Telephone (207) 623-7906**

Wage Determination - In accordance with 26 MRSA §1301 et. seq., this is a determination by the Bureau of Labor Standards, of the fair minimum wage rate to be paid to laborers and workers employed on the below titled project.

Title of Project -----2018.20-York Toll Plaza Replacement, MM8.8

Location of Project -York, York County

**2018 Fair Minimum Wage Rates
Building 2 York County
(other than 1 or 2 family homes)**

Occupation Title	Minimum			Occupation Title	Minimum		
	Wage	Benefit	Total		Wage	Benefit	Total
Asbestos/Lead Removal Worker	\$15.10	\$0.57	\$15.67	Ironworker - Ornamental	\$22.85	\$4.85	\$27.70
Backhoe Loader Operator	\$20.00	\$2.16	\$22.16	Ironworker - Reinforcing	\$24.79	\$10.60	\$35.39
Boom Truck (Truck Crane) Operator	\$21.66	\$6.86	\$28.52	Ironworker - Structural	\$21.25	\$3.25	\$24.50
Bricklayer	\$24.00	\$2.81	\$26.81	Laborers (Helper & Tenders)	\$15.00	\$1.10	\$16.10
Bulldozer Operator	\$20.00	\$4.06	\$24.06	Laborer - Skilled	\$17.00	\$2.89	\$19.89
Carpenter	\$23.88	\$4.12	\$28.00	Line Erector Power/Cable Splicer	\$26.00	\$7.59	\$33.59
Carpenter - Acoustical	\$17.00	\$2.68	\$19.68	Loader Operator - Front-End	\$19.13	\$2.95	\$22.08
Carpenter - Rough	\$19.00	\$2.47	\$21.47	Mechanic- Maintenance	\$25.50	\$3.69	\$29.19
Cement Mason/Finisher	\$17.25	\$0.79	\$18.04	Mechanic - Refrigeration	\$25.00	\$4.68	\$29.68
Communication Equip Installer	\$22.00	\$2.02	\$24.02	Millwright	\$26.00	\$11.58	\$37.58
Comm Transmission Erector- Microwave & Cell	\$17.00	\$0.00	\$17.00	Oil/Fuel Burner Serv/Instlr(Lic)	\$26.50	\$2.19	\$28.69
Crane Operator =>15 Tons)	\$25.13	\$5.94	\$31.07	Painter	\$17.00	\$0.55	\$17.55
Driller - Rock	\$18.38	\$2.60	\$20.98	Pipe/Steam/Sprinkler Fitter	\$23.00	\$4.49	\$27.49
Dry-Wall Applicator	\$22.42	\$2.76	\$25.18	Pipelayer	\$28.00	\$12.54	\$40.54
Dry-Wall Taper & Finisher	\$23.00	\$0.00	\$23.00	Plumber (Licensed)	\$26.00	\$4.13	\$30.13
Electrician - Licensed	\$28.00	\$5.22	\$33.22	Plumber Helper/Trainee (Lic)	\$17.57	\$3.31	\$20.88
Electrician Helper/Cable Puller	\$18.00	\$3.73	\$21.73	Propane/Natural Gas Serv/ Inst	\$26.55	\$1.93	\$28.48
Elevator Constructor/Installer	\$57.50	\$24.42	\$81.92	Rigger	\$20.00	\$6.12	\$26.12
Excavator Operator	\$22.00	\$2.08	\$24.08	Roofer	\$18.75	\$0.00	\$18.75
Fence Setter	\$16.00	\$1.17	\$17.17	Sheet Metal Worker	\$20.25	\$3.70	\$23.95
Flagger	\$12.00	\$0.00	\$12.00	Stone Mason	\$20.00	\$0.00	\$20.00
Floor Layer	\$18.75	\$3.72	\$22.47	Tile Setter	\$22.00	\$4.17	\$26.17
Furniture Installer/Assembler	\$16.00	\$1.24	\$17.24	Truck Driver - Light	\$18.15	\$2.88	\$21.03
Glazier	\$21.00	\$3.50	\$24.50	Truck Driver - Medium	\$17.75	\$1.82	\$19.57
Highway Worker/Guardrail Installer	\$16.75	\$0.80	\$17.55	Truck Driver - Heavy	\$16.00	\$2.06	\$18.06
HVAC	\$23.50	\$3.98	\$27.48	Truck Driver - Tractor Trailer	\$17.50	\$2.42	\$19.92
Insulation Installer	\$19.00	\$1.27	\$20.27				

The Laborer classifications include a wide range of work duties. Therefore, if any specific occupation to be employed on this project is not listed in this determination, call the Bureau of Labor Standards at the above number for further clarification.

Welders are classified in the trade to which the welding is incidental.

Apprentices - The minimum wage rate for registered apprentices are those set forth in the standards and policies of the Maine State Apprenticeship and Training Council for approved apprenticeship programs.

Posting of Schedule - Posting of this schedule is required in accordance with 26 MRSA §1301 et. seq., by any contractor holding a State contract for construction valued at \$50,000 or more and any subcontractors to such a contractor.

Appeal - Any person affected by the determination of these rates may appeal to the Commissioner of Labor by filing a written notice with the Commissioner stating the specific grounds of the objection within ten (10) days from the filing of these rates.

Determination No: B2-054-2018
Filing Date: July 13, 2018

A true copy

Attest: Scott R. Cotnoir
**Scott R. Cotnoir
Wage & Hour Director
Bureau of Labor Standards**

Expiration Date: 12-31-2018

BLS 424BU (R2012) (Building 2 York)

104.4.6 Utility Coordination

This Subsection is amended by the addition of the following:

These Special Provisions outline the arrangements which have been established by the Authority for coordination of the work to be accomplished by the utilities. The scope and schedule of utility relocation work is noted herein. The Contractor shall plan and conduct his work accordingly.

General

Utility working days are Monday through Friday, conditions permitting. Times are estimated on the basis of a single crew for each utility. Any times and dates mentioned are estimates only and are dependent upon favorable weather, working conditions, and freedom from emergencies. The Contractor shall have no claim against the Authority if they are exceeded.

The Contractor shall plan and conduct his operations in accordance with the following utility schedule. The Contractor must comply with all OSHA regulations pertaining to work adjacent to utility wires. The Contractor shall plan and conduct his work accordingly.

The following utilities are located within the Project limits. The Contractor shall ascertain the location of the existing utilities and any other necessary information by direct inquiry at the office of the following utility owners:

AERIAL UTILITIESCOMMUNICATION:

Fairpoint Communications

Project Coordination: Marty Pease

5 Davis Farm Road; Portland, Maine 04103

Phone: 207-797-1119

Fax: 207-797-1098

E-mail: mpease@fairpoint.com

Project Construction: Tracy Porell

3 Commerce Drive; Kennebunk, Maine 04043

Phone: 207-985-3513

Fax: 207-985-6149

E-mail: tporell@fairpoint.com

CABLE TELEVISION:

Spectrum

Project Coordination/Construction: Peter Deteso

118 Johnson Road; Portland, Maine 04103

Phone: 207-318-6542

E-mail: peter.deteso@twcable.com

ELECTRIC:

Central Maine Power Company
Project Coordination/Construction: Jamie Cough
162 Canco Road, Portland, Maine 04103
Phone: 207-629-1489
E-mail: cough@cmpeo.com

CENTRAL MAINE POWER (CMP)

Extend Three Phase primary power from Chases Pond Road to proposed Maine Turnpike Authority Administrative building. Provide electrical service for a streetlight at Chases Pond Road. Central Maine Power Company is the pole owner along Chases Pond Road and requires 80 working days to complete the work.

FAIRPOINT COMMUNICATIONS

Extend communication line from Chases Pond Road to proposed Maine Turnpike Authority Administrative building. Fairpoint Communications requires 6 working days once the pole owner has completed their work.

SPECTRUM CABLE

Extend communication line from Chases Pond Road to proposed Maine Turnpike Authority Administrative building. Spectrum Cable requires 15 working days once the pole owner has completed their work

UNDERGROUND UTILITIES

WATER:

York Water District
Superintendent: Donald Neumann, Jr.
86 Woodbridge Road; York, Maine 03909
Phone: 207-363-2265
E-mail: dneumann@yorkwaterdistrict.org

YORK WATER DISTRICT

Install approximately 1,600 linear feet of 16-inch ductile iron water main and associated appurtenances as depicted within the design plans. Contractor shall coordinate all work with York Water District for required inspections, testing, and notifications.

104.4.7 Cooperation with Other Contractors

This Subsection is amended by the addition of the following:

Adjacent contracts currently scheduled for the 2017 and 2018 construction season include:

MTA Contract 2017.08 – Guide Sign Contracts (2017 – 2019)

MTA bridge reconstruction projects at Mountain Road (2019), Littlefield Road (2020), existing York Toll Plaza Demolition (2021), and MaineDOT I-95 Maine/New Hampshire Bridge Wearing Surface project.

The following Subsection is added:

105.2.7 Use of Explosives – Subsection 105.2.7 of the Supplemental Specifications is DELETED and REPLACED with the following.

The use of explosives is permitted. Blasting shall be completed in accordance with the standards the Maine Revised Statutes Performance Standards for Quarries 38 M.R.S.A 490-Z (14). Prior to any blasting the Contractor must submit a detailed blasting plan to the Resident at least three (3) weeks prior to commencing drilling and blasting operations. The pre-blast survey radius shall be 2000 feet, unless the radius can be reduced using the formula at 38 M.R.S. §490-Z(14)(F)(3). The blasting plan shall contain the following information:

- a. Site plan with location of nearest structures and abutters. Plan shall also show the location of all public and private wells.
- b. Plan of each blast showing hole-spacing and delay pattern;
- c. Diameter and depth of each hole;
- d. Amount of explosive per hole;
- e. Total pounds of explosives per delay;
- f. Total amount of explosives per blast;
- g. Type of non-electric delays to be used;
- h. Amount of stemming in each hole;
- i. Type of explosive to be used;
- j. Soil and rock profile in blast zone;
- k. Scale distance to the nearest abutting structure;
- l. Type and location of seismograph to be used;

- m. Size of blasting mats and cover to be used; and,
- n. Safety precautions to be followed.

After submission of the blasting plan, but prior to the start of the blasting program, the blasting Contractor shall meet with the Resident, Maine Turnpike Authority officials, State Police (turnpike barracks), and affected utility representatives. The purpose of the meeting is to advise them of their blasting plan and schedule, accept feedback on the proposed plan, and coordinate the blasting effort.

Should field conditions warrant a change in the general blasting plan, the blasting Contractor shall provide a sketch and blasting plan details based on the actual field conditions prior to the blast for inclusion in the Project records.

The following general requirements are to be adhered to:

- A. Blasting permits shall be obtained by the Contractor from all State and Federal agencies having jurisdictions. Blasting will not be authorized by the Resident without proper permits.

The Contractor shall comply with all applicable laws, rules, ordinances, and regulations of the Federal Government, the State of Maine, and the city or town governing the transportation, storage, handling, and the use of explosives including 38 M.R.S.A 490-Z (14). All labor, materials, equipment, and services necessary to make the blasting operations comply with such requirements shall be provided at no additional costs to the Authority.

The Contractor shall obtain and pay for all permits and licenses required to complete the work of this Section.

In case of conflict between regulations or between regulations and Specifications, the Contractor shall comply with the strictest applicable codes, regulations or Specifications.

The Contractor shall notify all abutters within a 2000 foot radius of the blasting site in accordance with the requirements of the DEP permit.

- B. Obtain the services of a qualified vibration and blasting expert to monitor the blasting. All seismographic instruments shall be capable of producing a permanent record of the information required to determine the particle velocity at any time during all phases of the blasting operation. A copy of all recording shall be furnished to the Authority within two (2) working days after a blast. Seismographic recordings shall be taken at the critical locations and additional instruments shall be furnished, located and operated as deemed necessary by the Resident.

Persons responsible for blasting shall be Licensed Blasters in the State of Maine and shall have had acceptable experience in similar excavations in rock and controlled blasting techniques.

- C. Non-electric detonation systems shall be used. Electric blasting caps will not be permitted.
- D. The Contractor shall conduct all blasting activity in such a manner that the peak particle velocity of ground vibration, measured at the locations of the nearest structures to the blast, does not exceed the “safe limits” recommended by the U.S. Bureau of Mines in

FIGURE B-1 of BUMINES RI 8507, as follows:

FIGURE B-1

BUMINES RI 8507

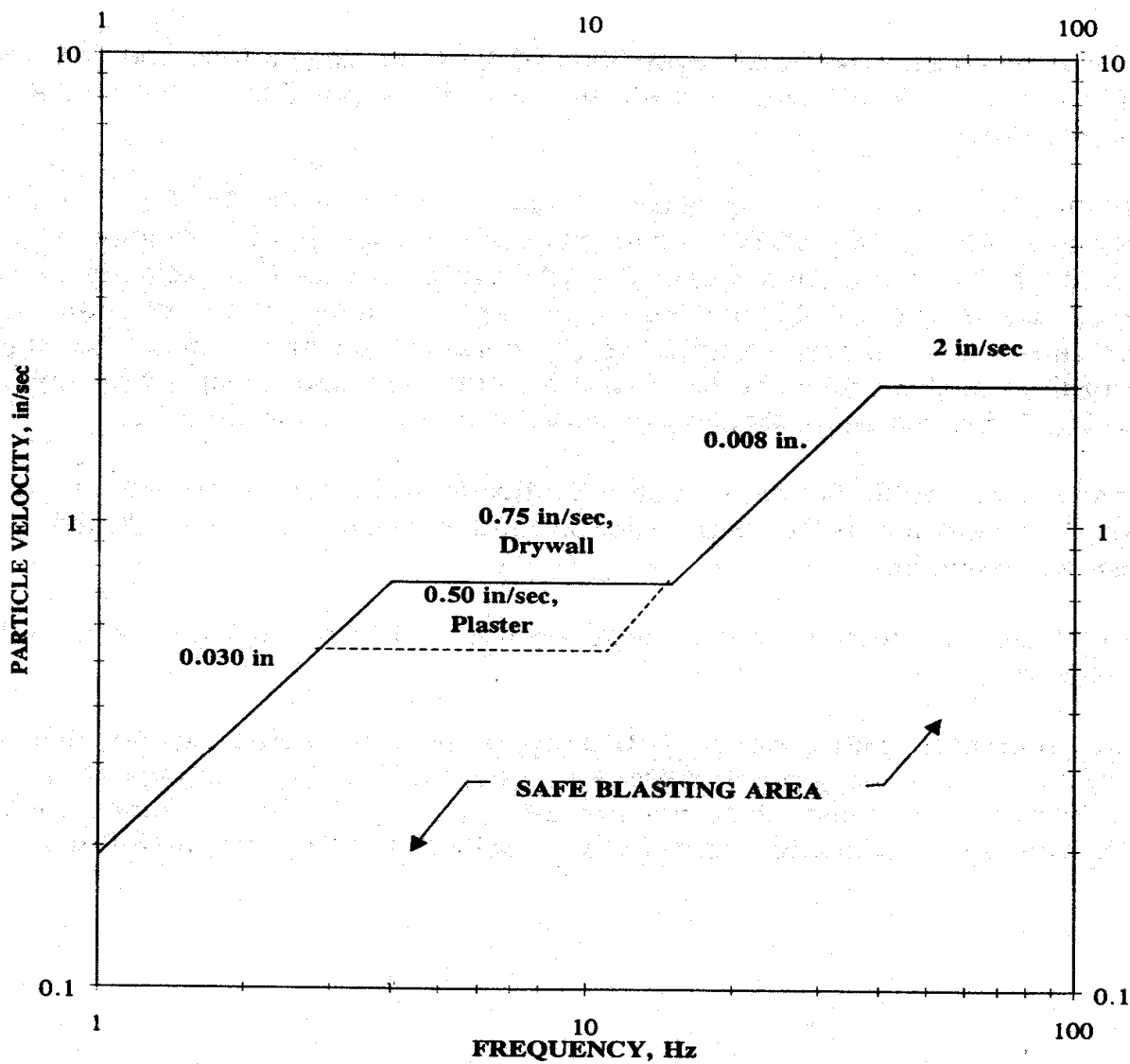

Figure B-1 - Safe levels of blasting vibration for houses using a combination of velocity and displacement

ALTERNATIVE BLASTING LEVEL CRITERIA

- E. The Contractor shall conduct all blasting activity in such a manner that the sound from blasting measured at the locations of the nearest above ground occupied structures to the blast does not exceed the following limits:

<u>Number of Blasts Per Day</u>	<u>Sound Level Limit</u>
1	129 decibels
2	126 decibels
3	124 decibels
4	123 decibels

- F. Scaled distance factors permitted for various distances from blast:

<u>Distance from blast site (ft)</u>	<u>Scaled distance factor to be used without seismic monitoring (ft)</u>
0 to 300	50
300 to 5000	55
5000 and beyond	65

- G. The Contractor shall advise the Resident at least five (5) working days in advance of the dates on which he proposes to perform blasting operations, providing an approximate hour for the Resident's approval. The Authority will provide police at the turnpike site, who will stop traffic in both directions while the blast is detonated. The Contractor will be responsible for providing all traffic control required to close local streets during periods of blasting.

H. Safety Precautions

1. Clearing Danger Area Before Blasting - no blasting shall be permitted until *all* personnel in the danger area have been removed to a place of safety. A loud, audible warning system, devised and implemented by the Contractor, shall be sounded before each blast. The Contractor shall familiarize all personnel on the Project, Authority, Police Officers, Residents, and the general public with the implemented system. The danger area shall be patrolled before each blast to make certain that it has been completely cleared, and guards shall be stationed to prevent entry until the area has been cleared by the blaster following the blast.
2. Explosives shall be stored, handled and employed in accordance with Federal and State regulations.
3. No explosives, caps, detonators or fuses shall be stored on-site during non-working-hours.
4. The Contractor shall use sufficient stemming, matting or natural protective cover to prevent flyrock from leaving property owned or under control of the

Maine Turnpike Authority or from entering protected natural resources or natural buffer strips. Crushed rock or other suitable material must be used for stemming when available; native gravel, drill cuttings or other material may be used for stemming only if no other suitable material is available. Blasting mats shall be used to cover the top and vertical face of all blasts in order to minimize the possibility of excessive throw of rock.

5. The Contractor is advised that the Authority's Maintenance Forces and State Police use two-way radios in the vicinity of the Project. These radios cannot be turned off during loading operations. Therefore, non-electric detonation systems shall be used. Electric blasting caps will *not* be permitted.
6. The Contractor shall be responsible for determining any other safety requirements unique to blasting operations at these particular sites so as not to endanger life, property, utility services, any existing or new construction, or any property adjacent to the site.
7. No requirements of, or omissions to, require any precautions under this Contract shall be deemed to limit or impair any responsibility or obligations assumed by the Contractor under or in connection with this Contract; and the Contractor shall at all times maintain adequate protection to safeguard the public and all persons engaged in the work, and shall take such precautions as will accomplish such end, without undue interference to the public. The Contractor shall be responsible for and pay for any damage to adjacent roadways or structures resulting from work executed under this Section.
8. The Contractor is required to secure all travelways, entrances and exits within 300 feet of the blast zone. No vehicles or pedestrians will be allowed within the 300-foot-zone until the blast is complete, all debris is cleaned from the roadways, and the site is deemed safe by the blasting contractor and the Resident.

I. General Blasting Procedures

1. Explosives will be restricted to non-peak periods per Special Provision 652. The use of explosives is not permitted on Friday, weekends (Saturday and Sunday), holidays, on the eve of a holiday, or during non-daylight-hours unless approved in writing by the Resident. A blast may be allowed early on a Friday morning before 6:00 a.m. if it can be completed during daylight-hours. Specific allowable blasting times are outlined in Special Provision 652 Maintenance of Traffic (Allowable Blasting Time). In order to minimize traffic disruptions, the Contractor shall schedule blasting such that all disrupted traffic shall be cleared between any two successive blasts detonated anywhere on the Project. The Contractor will be allowed as many mainline traffic stoppages as can be cleared in the designated blasting window, provided the blast schedule can be safely coordinated. Each stoppage will be counted as one complete stoppage of mainline traffic. The Authority may withhold permission to blast if, in the opinion of the Authority, actual or anticipated traffic volumes will produce mainline or local road congestion that cannot be cleared in a reasonable amount

of time. The Contractor's blasting operations shall be performed using extreme care to minimize the inconvenience and interruption to traffic and damage to the existing pavement, structures and surrounding areas.

2. The Contractor shall have sufficient equipment available on-site to clear the pavement of blast rock, if it is necessary. At a minimum, the Contractor shall have a vehicle to sweep the pavement and a half-ton pickup equipped with a plow. The blast will not be allowed to occur if this equipment is not present.
3. The Contractor shall coordinate all blasting with the Resident on-site who shall determine in advance when the charges may be set.
4. Blast hole diameter shall not be greater than three inches.
5. No free flowing, pourable or pumpable explosives shall be used unless approved by the Resident. All explosives shall be in cartridges or other semi-rigid containers.
6. Mainline traffic control during blasting periods shall be in accordance with the Plans and Specifications.. Traffic control signs shall meet the requirements of Section 652 and will be paid for under Item 652.35, Construction Signs. The setup and removal of signs and the coordination with State Police for mainline blasting is incidental to Subsection 652.361, Maintenance of Traffic Control Devices.
7. Local traffic control during blasting periods shall be in accordance with MUTCD and local requirements. All temporary signage shall be removed when the daily blasting period is over. Local traffic control signs shall meet MUTCD requirements and will be measured for payment as construction signs. Providing flaggers on local roads, if required for blasting, will be measured for payment.
8. The Contractor shall report to the Resident, in writing, all blasting complaints received by the Contractor within 24-hours of receipt. Each blast complaint report shall include the name and address of the complainant, time received, date and time of blast complained about, and a description of the circumstances which led to the complaint. Upon receipt of a written complaint alleging damage from the blasting, the Contractor's vibration and blasting consultant and/or a representative of the blaster's insurance company shall investigate the claim and a written report shall be issued to the complainant, with a copy to the Resident, of the results of the investigation and the response of the Contractor. This written report shall be received by the complainant and Resident within 15 work days of receipt of the written complaint.
9. The maximum time for which traffic may be stopped at any single time shall be six (6) minutes. This duration shall be measured as the time between the time that the last car passes the Resident, until the time the Resident determines that all travel lanes are cleared of blast debris. The Contractor shall reduce the size of the blast, change the design and method of the blast, use more mats, or otherwise alter the blasting so that the traffic is not stopped for

more than six minutes. If, due to the throw of rock onto the highway or other blasting related activities, traffic is stopped for more than six minutes, the Contractor shall pay a penalty of \$1000.00 per minute for every minute traffic is stopped in excess of the six minute limit. The penalty shall be measured separately on the northbound and southbound roadway (or eastbound and westbound roadway). Total penalties will be deducted from the next pay estimate. Whenever the volume of traffic is excessive such that a six minute interruption would cause objectionable congestion, in the opinion of the Authority, the hours during which blasting may occur may be further restricted.

J. Pre-Blast Condition Survey

The Contractor shall provide a pre-blast survey as described below:

Prior to start of blasting work, the Contractor shall conduct a pre-blast condition survey of all existing structures and conditions on the site, adjacent to the site, or in the vicinity of the site. This survey shall extend to such structures or conditions as may be affected by the Contractor's construction operations. Surveys shall be performed on all structures within 2000 feet of anticipated blasting areas unless the radius can be reduced using the formula at 38 M.R.S. §490-Z(14)(F)(3). As a minimum condition surveys shall be performed on all structures within 500 feet of anticipated blasting. The Contractor is responsible for the following:

1. Coordinate activities, issue notices, obtain clearances and provide whatever photographic and secretarial assistance is necessary to accomplish the survey.
2. Give notice, in writing, to the owner of the property concerned and tenants of the property. Advise in notice, the dates on which surveys are to be made so that they may have representatives present during the examination. Provide copies of all notices to the Resident.
3. The survey shall consist of a description of the interior and exterior conditions of the various structures examined. Descriptions shall locate any existing cracks, damage or other defects existing, and shall include such information so as to make it possible to determine the effect, if any, of the construction operations on the defect. Where significant cracks or damage exist, or for defects too complicated to describe in words, photographs shall be taken and made part of the record.
4. The survey shall include a test of all public and private wells in the area. Water quality tests shall be obtained so that a baseline condition may be developed.

Contractor's record of the pre-blast condition survey shall consist of written documentation and photographs of the conditions identified, or a good quality videotape survey with appropriate audio description of conditions and defects. Prior to start of work, one copy of the Contractor's record of conditions survey shall be submitted to the Resident for review and retention.

Upon completion of all excavation (earth/rock) and blasting work, the Contractor shall make an examination similar to the pre-construction survey of any properties, structures, and conditions where complaints of damage have been received or damage claims have been filed. Notice shall be given to all interested parties so that they may be present during the final examination. Records of the final examination shall be distributed the same as the original preconstruction survey.

K. Payment

No separate measurement or payment will be made for the work outlined in this Section including the detailed blasting program, pre-blast and post-blast surveys, blasting and permit acquisitions. All cost associated with this work shall be incidental to the Rock Excavation item(s).

L. Indemnity

Notwithstanding full compliance with these Specifications, approval of blasting plan, and successful limitation to maximum peak particle velocity noted above, the Contractor shall be solely responsible for any damage, direct or indirect, arising from blasting and shall hold the Authority and Resident harmless from any costs, liens, charges, claims or suits, including the costs of defense, arising from such damage, real or alleged. The Authority and Resident shall be additionally-named insured on any insurance policy covering blasting carried by the Contractor, and this requirement shall also be enforced on any subcontractor.

The Contractor shall provide a pre-blast and post-blast survey including photographs. An inspection of all facilities within and adjacent to the Contract limits shall be made to determine any changes that may occur due to the blasting operations.

The Resident's approval shall not relieve the Contractor of any responsibility for any hazards or damages related to this work. The use of explosives shall conform to all Federal and State laws and regulations. Explosives must not be stored within the turnpike right-of-way. Explosives shall be in the care of competent watchmen at all times, and placement and detonation shall be performed under the direction of a qualified blaster licensed in the State of Maine.

105.8.2 Permit Requirements

The Project is being permitted under the Maine Department of Environmental Protection (MDEP) Site Location of Development Act General Permit for the Maine Turnpike Authority (MTA GP) which authorizes the MTA to construct or cause to be constructed or operate or cause to be operated all developments under the MTA's authority for which approval is required pursuant to the Site Law, 38 M.R.S.A 481-490, after the approval by the DEP of the Notice of Intent as set forth in 38 M.R.S.A. _486-B (3). A copy of the MTA GP is attached in Appendix H. A copy of the MDEP Approval Order is attached in Appendix I.

The project is permitted under a Tier 3 Natural Resources Protection Act (NRPA) issued by MDEP. A copy of the permit MDEP Approval Order is attached in Appendix I.

The Project is being permitted under Section 404 of the Clean Water Act, through the US Army Corps of Engineers Programmatic General Permit, Category 2. The Project is subject to the General Conditions of the Category 2 Authorization dated October 13, 2015 through October 13, 2020. A copy of the USACE General Permit Authorization Letter is attached in Appendix J and a copy of the Maine General Permit is attached in Appendix K.

The Contractor shall prepare a Limit of Disturbance (LOD) plan illustrating the Contractor's proposed limit of earthwork disturbance. The LOD plan shall show all construction access locations, field office locations, material and temporary waste storage locations, as well as include the Contract limits of earthwork disturbance. All applicable erosion and sedimentation control devices needed shall be detailed on the Contractor's LOD plan and are not limited to those devices shown on the Contract LOD plan. **This Plan shall be submitted for review and approval, to the Resident within 14 days of Contract award.** Payment for creating, revising, and completing this plan shall be incidental to Item 659.10, Mobilization.

The LOD for this Contract, which were submitted as part of the Notice of Intent (NOI), has been estimated to be 34 acres.

At any time during the Contract, if the Limit of Disturbance needs to be adjusted to accommodate construction activities, the Contractor shall resubmit the LOD plan (including any additional erosion and sedimentation control measures needed) to the Resident for review and approval prior to any additional disturbance. Changes in the limit of disturbance may require resubmittal of the NOI for MaineDEP approval and/or modifications to ACOE Permit, MDEP Tier III permit and MaineDEP General Permit. Any re-approvals that are necessary, will take several weeks or longer to complete and the Contractor shall not go outside the approved limits until such time that the re-approvals are issued. The Contractor shall not be entitled to any additional compensation for time delays to acquire any re-approvals.

Compliance with the erosion and sedimentation control requirements outlined in this Contract is required by the Contractor.

The Contractor shall comply with the conditions outlined in the Maine Department of Environmental Protection Site location of Development General Permit Notice of Decision, NRPA Permit the US Army Corps of Engineers General Permit and the Maine Pollutant Discharge Elimination System General Permit for stormwater discharge associated with construction activity. The Contractor shall indemnify and hold harmless the Maine Turnpike Authority or its agents, representatives and employees against any and all claims, liabilities or fines arising from or based on the violation of the above noted permits.

This Project is also subject to the requirements of the Maine Pollutant Discharge and Elimination System (MPDES) General Permit for the Discharge of Stormwater from MTA's Municipal Separate Storm Sewer Systems (MS4). MS4 compliance requires all Contractors to be properly trained in Erosion and Sedimentation Control (ESC) measures (as per Special Provision Subsections 105.8.1 and 656.07) and implement measures to reduce pollutants in stormwater runoff from construction activities.

107.1 Contract Time and Contract Completion Date

This Subsection is amended by the addition of the following:

All work shall be completed on or before June 21, 2021. The contract completion shall include completion of all contract work and all punch list items.

107.4.2 Schedule of Work Required

This Subsection is amended by the addition of the following:

The work shall be completed in logical timely increments. The Contractor shall submit a schedule for review that shows large segments of work scheduled for continuous blocks of time. Work in a segment shall be completed over a period of continuous work days. Work shall not be started in an area until the Contractor has scheduled the labor and equipment necessary to complete all work in the segment. The Contractor will not be permitted to “stretch” the Project over the entire Contract period, doing a day or two work per week.

A schedule that shows sporadic work activities through the duration of the Contract will not be approved. Actual work activities that are sporadic will not be allowed.

A two (2) week schedule shall be submitted by the Contractor weekly, the first week shall be detailed. The weekly detailed schedule shall show all lane closures that are anticipated for the following week. Lane closures that are not shown on this schedule will only be allowed if they are deemed emergency lane closures by the Resident.

107.4.6 Prosecution of Work

The following is a summary of the Construction Stages and key dates:

The work at the new toll plaza including the administration building shall be accomplished in three (3) major phases of construction, Phase 1, Phase 2 and Phase 3. Phase A, Phase B and Phase C shall be performed within Phases 1 and 2.

Phase 1 and Phase 2: Project Start to end of Phase 2.

Phase 1:

With traffic maintained in the existing northbound and southbound lanes and reduced outside shoulder widths, the work includes the construction of the northbound and southbound widening at the proposed toll plaza and along the mainline. Work includes clearing; rock excavation; excavation and embankment; granular subbase and base pavement materials; HMA pavement to binder grade; proposed drainage improvements; precast and cast-in-place tunnel construction; utility construction including water and electric; temporary pavement markings and signs; earthwork and pavement for temporary widening; and temporary traffic control.

The Contractor shall provide three (3) 12 foot lanes with existing shoulders along the median with four foot outside shoulders and temporary barriers.

Also included is the construction and completion of the new administration building, access road and parking area.

Phase A:

Included is the full depth pavement construction and pavement shimming from northbound Sta. 1371+50 to Sta. 1379+00 and from southbound Sta. 2370+00 to Sta. 2379+25.

During Phase A, the Contractor shall provide two (2) 12 foot travel lanes with 2' – 4' reduced shoulder widths and temporary barrier in both northbound and southbound directions in order to construct the pavement widening required to support the travel lanes and shoulders required for Phase B.

This work also includes the construction of the drainage culvert at Sta. 374+77 which will require work during off peak hours using daily lane closure(s) to facilitate the construction and maintenance of traffic.

Phase B:

Included is the full depth pavement construction and pavement shimming from northbound Sta. 1371+50 to Sta. 1379+00 and from southbound Sta. 2370+00 to Sta. 2379+25.

The transition from Phase A to Phase B will shift the two mainline travel lanes in each direction onto two (2) 11 foot lanes with 2' minimum shoulders constructed in Phase A. The Contractor shall immediately begin the pavement construction so that the third lane (inside lane) can be opened to traffic, providing three (3) 11 foot travel lanes with 2' - 4' reduced shoulder widths in both directions (2' minimum shoulders).

This work also includes the construction of the drainage culvert at Sta. 374+77 which will require work during off peak hours to provide daily lane closure(s) to facilitate the construction and maintenance of traffic.

The period of time in Phase A and Phase B, during which the northbound and southbound travel lanes are reduced to two lanes with shoulders in each direction, shall be no longer than 24 calendar days with incentive and disincentive payments.

Phase 2:

Upon completion of the permanent and temporary widening necessary in Phase 1, traffic will be shifted from the existing lanes to the temporary lanes shown in Phase 2. Work includes the rock excavation; excavation and embankment; granular subbase and base pavement materials; permanent HMA pavement to binder grade; proposed drainage improvements; precast and cast-in-place tunnel construction; utility construction including water and electric, mechanical, electrical, plumbing and ITS systems in the tunnel; major portions of the northbound and southbound median and cash lane barrier; ORT space frame, footings and concrete slab; canopy footings for inside cash lanes; and temporary traffic control.

The northbound and southbound ORT lanes will be turned over to the Authority for commissioning. No work shall be performed on the ORT lanes and shoulder, including the cash lane barriers, for a distance of 1,400 feet north and south of the ORT facilities.

The system Integrator shall commence ORT lane commissioning testing after both the northbound and southbound ORT facilities are complete and will complete the commissioning no later than 126 calendar days from the Authority's acceptance that both the northbound and southbound ORT facilities are complete. It is preferred that both northbound and southbound ORT are turned over to the Authority for commissioning testing as the same time, but in no case shall one barrel be turned over to the Authority later than 30 calendar days after the first. The 126 days of commissioning for each bound begins from the Authority's acceptance of that bound.

The Contractor shall provide and maintain traffic control associated with the testing of ORT equipment including providing sufficient roadway approaches to ORT facilities to properly test the operation at highway speeds. The Contractor shall coordinate traffic control requirements with the tolling engineer and system integrator including any adjustments to the temporary traffic control measures needed for ORT testing.

The Contractor may continue working in Phase 2, Phase A and Phase B work area during commissioning, except for the area required for the ORT commissioning described above. It is the Contractor's responsibility to maintain long-term lane closures of the ORT zones and cash lanes and maintain all proposed ORT and cash lanes signage covered until the ORT and cash lanes are operational.

Phase C:

Phase C provides for the long term configuration, including winter shutdown, of Phase 2. The work involves shifting the three lanes of northbound and southbound traffic, north of the toll plaza, toward the median by one full travel lane to provide widened shoulders (8 foot minimum) on both sides. The temporary barrier along the outside shoulder from Phase 2 shall remain in place, and the outside lane shall become the outside shoulder. The Contractor shall remove/relocate the temporary barrier on the median side and provide temporary pavement markings and signage to accommodate the lane shifts and widened shoulders. The travel lanes and shoulders, including the pavement supporting the temporary barrels or barrier, shall be at the same elevation – there shall be no longitudinal pavement drop-off.

Phase 3: From Phase 3

Phase 3:

Upon completion of the work on Phase 2, Phase A, Phase B, and the ORT northbound and southbound commissioning, the three travel lanes will be shifted from the outside temporary alignments to the three (3) 12 foot travel lanes with 12 foot shoulders (4 foot minimum) along the ORT lanes in each direction.

The ORT's will be commissioned at this time, but not operational to collect tolls. Work includes completion of the northbound and southbound cash plazas; tunnel construction and mechanical, electrical, plumbing and ITS systems; completion of the median barrier; removal of

temporary pavement and pavement widening; HMA pavement and final surface course; completing side slopes and open drainage to final grades; signing and striping; and commissioning of the northbound and southbound cash plazas, and traffic control.

The Contractor shall maintain a minimum of three (3) 12 foot travel lanes, 2 foot minimum left shoulder and 4 foot minimum right shoulder during construction of the median and median barrier from station 306+00 to 332+00.

The northbound cash lanes and southbound cash lanes will be turned over to the Authority for commissioning. No work shall be performed at the toll plazas or on the pavement from the cash lane barrier to the edge of pavement. The commissioning and testing on the northbound cash lanes may be done separately from the southbound cash lanes to facilitate the construction schedule.

The system Integrator shall commence cash lane commissioning and testing after both the northbound cash plaza and southbound cash plaza are complete, and will complete the southbound plaza commissioning no later than 70 calendar days, and the northbound plaza commissioning no later than 56 days, from the Authority's acceptance that both the northbound plaza facility and southbound plaza facility are complete for commissioning.

The Contractor shall provide and maintain traffic control associated with the testing of cash plaza equipment including providing sufficient roadway approaches to facilities to properly test the operation at highway speeds. The Contractor shall coordinate traffic control requirements with the tolling engineer and system integrator including any adjustments to the temporary traffic control measures needed for plaza testing.

The Contractor may continue working in the Phase 3 work area during commissioning, except for the area required for the plaza commissioning described above. It is the Contractor's responsibility to maintain long-term lane closures of the cash plazas and maintain all proposed signage, and covering of signs, until the cash plazas are operational.

The end of Phase 3 marks the completion of the new toll plaza at MM 8.8. This work shall be completed by **June 21, 2021**.

Supplemental Liquidated Damages

Supplemental liquidated damages of Five Thousand (\$5,000.00) Dollars per calendar day per the following dates or phase durations shall be assessed for each calendar day that activities listed above are not completed:

Interim Completion Date	Supplemental Liquidated Damages Date	Supplemental Liquidated Damages per calendar day
Waterline Completion Date	March 1, 2019	\$5,000

The "day" begins at 12:01 a.m. and ends at 12:00-midnight.

Incentive/Disincentive Payments

Incentive/Disincentive payment for Phase A –Phase B (north end full depth area):

From October 15 to November 16, 2019 or from April 1 to May 6, 2020, a permanent single lane closure will be allowed for Phase A and Phase B.

The Incentive/Disincentive activity is for the period of time during which the northbound or southbound travel lanes are reduced to the two lanes during Phase A and Phase B.

The total duration period for this activity for northbound or southbound is 24 calendar days. The duration begins on the day when the traffic is restricted to 2 lanes in Phase A. The duration ends when the travel lanes are open to three (3) travel lanes and shoulders in Phase B. Traffic shall be traveling on binder pavement at the end of this activity, and work may continue in Phase 2 / Phase B to complete the full depth construction.

An Incentive payment for early completion of Five Thousand (\$5,000.00) Dollars per calendar day shall be paid for each calendar day (up to a maximum of 7 days) that activity listed above are completed prior to a 24 calendar day total duration, for northbound and southbound separately. This is separate and distinct from the Liquidated Damages and Supplemental Liquidated Damages.

A Disincentive penalty of negative Five Thousand (\$-5,000.00) Dollars per calendar day shall apply for each calendar day that the activity is not completed beyond the 24 calendar day duration, for northbound and southbound separately. There is no limit on the disincentive.

107.4.7 Limitations of Operations

Construction dates and restrictions for the construction and testing of the water main shall be in accordance with the requirement of the York Water District per Special Provision 822 Water Supply Main.

Lane and shoulder closures required to perform daily and short term operations, as well as overhead operations and equipment moves, shall be allowed in accordance with the tables provided in Special Provision 652 – Maintenance of Traffic - Specific Project Maintenance of Traffic Requirements. The Contractor shall provide strict adherence to lane and shoulder closures in accordance with these tables unless authorized by Authority.

Wide loads are restricted from moving on the turnpike from a half hour after sunset until a half hour before sunrise.

Wide loads must be able to safely pass all daytime work areas.

The Contractor shall submit the proposed staging and storage areas for approval by the Resident. All equipment and material storage must be located no closer than 30 feet from the edge of travel way, unless protected by temporary barrier. Proposed material and equipment storage locations shall be selected based on (1) proximity to UIS/Protected Natural Resources; (2) minimizing rutting or other actions that may hinder sheet flow from roadway; and (3) spill control and prevention, in the event of a fluid release from the equipment.

Material and equipment and vehicles stored behind temporary barrier must be located beyond the maximum barrier system deflection to allow for proper barrier deflection.

For paving operations under active traffic, the Contractor will be allowed to mill the entire work area prior to beginning the paving operation in that work area provided the milled pavement areas can be surfaced within one week. A maximum mill depth of 4" is required. Longitudinal joints adjacent to active traffic or where traffic drives over joint shall use a safety edge.

Care shall be taken when working near catch basins to ensure foreign material and contaminants do not enter the stormdrain systems. If foreign material and/or contaminants enter a catch basin(s), such material shall be removed prior to the material exiting the catch basin and into the stormdrain system and waterway. The Contractor shall remove and properly dispose of this material to the satisfaction of the Resident. Payment shall be incidental to the Contract.

The Contractor shall not install sheet piling or other driven or hammered systems for temporary excavation support or permanent installations during non-daylight hours or within 10 feet of an active traffic lane.

The Contractor vehicle and equipment access to and from the mainline shall provide the least interference with mainline traffic flow at any time. The Contractor shall locate access locations to the work area(s) which provide adequate acceleration/deceleration length and sight distance to and from the mainline, including appropriate warning signs. The Contractor may use the existing shoulders if available for acceleration/deceleration length, but at no time shall active shoulders be used for queuing construction vehicles. When existing shoulders are not available, the Contractor shall establish, construct and maintain facilities within the work area for acceleration/deceleration and merging with the mainline traffic. When access or egress points are not active, all warning signs shall be covered or removed, and appropriate traffic control devices shall close the access locations. When access or egress points are no longer necessary, signage shall be removed and appropriate traffic control devices shall close the access locations.

The Contractor shall use the I-95 mainline for the hauling and delivery of materials and equipment for the construction of this project. Chases Pond Road shall not be used by the Contractor for hauling and delivery of materials and equipment for construction of this contract, except for the construction of the proposed access road, parking lot and administration building. Chases Pond Road shall be the responsibility of the Contractor to properly repair to original condition, as determined by the Resident.

The length of temporary barrier installed during each Phase of work shall be limited to the Contractor's active work area, unless specifically required. The Contractor shall sequence the work within each Phase in a logical manner that minimizes the length temporary barrier along one or both sides of the active mainline traffic including temporary alignments. When construction or operations in a work area is complete and matches existing surface, the temporary barrier shall be removed or moved away from the active lane providing that a minimum 8 foot paved area can be used as an appropriate shoulder. If the temporary barrier is removed, appropriate traffic control devices will be employed to delineate the mainline edge of shoulder.

The Contractor shall not begin any portion of work that cannot be completed in the construction season prior to winter suspension of work. The intent is to not leave an element of construction incomplete during the winter suspension that will impede mainline traffic flow, maintenance of traffic, winter maintenance operations, or otherwise require the removal and replacement of the work.

The Contractor shall not schedule or begin any work that would require the shift of traffic to the median through the winter months. The Contractor shall not shift traffic toward the median for any portion of work that would remain during the winter months, either as a planned construction event or unforeseen circumstance that would extend this work through the winter months. Should an unforeseen circumstance not allow for the adequate completion of this work, the Contractor shall perform the work necessary to return the traffic to the previous configuration prior to winter suspension of work.

From October 15 to November 16, 2019 or from April 1 to May 6, 2020, a permanent single lane closure will be allowed for Phase A and Phase B.

Temporary transitional pavement ramps will be constructed at the ends of the pavement work transverse to direction of traffic. The pavement ramps shall be constructed prior to opening the lane(s) to traffic. This work shall not be measured separately, but shall be incidental to Item 403.

Permanent signs shall not be installed more than two weeks in advance of the lane or toll facilities for which the sign legend is for being open to traffic. Permanent signs covered until the lanes or toll facilities for which the sign legend is for being open to traffic shall not be covered for more than two weeks.

The commissioning of the northbound and southbound ORT lanes require that the complete electrical and communications services and devices are installed on the ORT pavement and space frame, in the tunnel, and connected to the server room in the administration building. The server room shall be complete to allow for complete operation of the ORT lanes so that commissioning can be completed.

110.1 Indemnification

This Subsection is amended by the addition of the following paragraph:

For any work associated with the water line the Contractor agrees to indemnify , defend , and hold harmless the York Water District and its officers, directors, employees, agents and consultants from and against all claims, actions, torts, costs, losses, and damages for bodily injury (including sickness, disease, or death) and property damage arising out of or relating to this Contract or the performance of Work by the Contractor, its Subcontractors, subconsultants, Engineers, suppliers, any individuals or entities directly or indirectly employed by any of them, or anyone for whose acts any of them may be liable, excepting only claims directly and solely caused by the negligence of the York Water District. Damages covered include, but are not limited to, all Dispute resolution costs including court costs, attorney's fees, and the fees of Engineers and consultants, arbitrators, and other professionals related to Dispute defense and preparation.

110.3.9 Administrative & General Provisions

This Subsection is amended by the addition of the following:

Under Paragraph A, Additional Insured, in addition to the Authority, The York Water District shall also be named as an additional insured.

SPECIAL PROVISIONSECTION 202REMOVING STRUCTURES AND OBSTRUCTIONS

(Abandoning Monitoring Wells)

202.021 Abandoning Monitoring Wells

The following paragraphs are added:

The Maine Turnpike authority has installed monitoring wells within the limits of new work. These wells are comprised of two (2) two-inch-diameter groundwater observation wells installed in borings B-3 and B-13 at respective depths of 2 feet to 6 feet below the ground surface in B-3 and from 2 feet to 12 feet below the ground surface in B-13; both wells were completed at the surface with standpipes.

These wells shall be tremie grouted beginning from the well screen bottom and continuing upward to the ground surface. The plugging material shall consist of either:

1. Cement with a 2%-5% by volume weight of bentonite mixture; or
2. High solids bentonite grout.

The cement/grout mixture shall be mixed according to the manufacturers specifications to produce a flowable (i.e. pumpable) consistency. The well shall be filled with grout to within 2 feet of the downcut casing. The last 2 feet of casing shall be filled with cement or clean soil to ensure a solid surface exists at ground surface. The surface casing shall be cut down to a minimum of 2 feet below proposed grade.

202.05 Method of Measurement

Abandoning monitoring wells shall be measured as unit price each for each well abandoned regardless of depth.

202.06 Basis of Payment

The accepted quantity of monitoring wells shall be paid for at the contract unit price each, which price shall include all work, labor, materials and equipment and shall include disposal of any well casing removed.

Payment will be made under:

<u>Pay Item</u>	<u>Pay Unit</u>
202.60 Abandon Monitoring Well	Each

SPECIAL PROVISION

SECTION 202

REMOVING STRUCTURES AND OBSTRUCTIONS

(Removing Existing Manholes or Catch Basins)
(Abandoning Existing Manhole or Catch Basin)

202.05 Removing Manholes or Catch Basins

The following sentence is added:

Frames and grates shall be removed, transported and stacked at the York Maintenance Facility.

Contractor shall remove existing manhole or catch basin whenever the center of an existing structure is located within 10 feet center to center distance of a proposed manhole, catch basin, or other similar structure. If the center of existing structure that is not incorporated in the proposed structure is more than 10-feet from a proposed structure, the structure shall be abandoned in place as described below.

Add the following section:

202.051 Abandoning Existing Manhole or Catch Basin

Existing manholes or catch basins to be abandoned as indicated on the plans or as directed by the Resident shall be have the frame and grate/removed, transported and stacked at the York Maintenance Facility. The top of the structure shall be removed such that no part of the structure is within three-feet of proposed finish grade and then completely filled with flowable fill meeting the requirements of Special Provision 602.

202.07 Method of Measurement

The last paragraph is deleted and replaced with the following:

Removing Manholes or Catch Basins will be measured by each unit satisfactorily removed.

Abandoning Existing Manhole or Catch Basin will be measured by each unit satisfactorily abandoned.

202.08 Basis of Payment

The following is added after the first sentence of the fourth paragraph:

Removing, transporting and stacking the frames and grates will not be paid for separately, but shall be incidental to the Removing Existing Manholes or Catch Basin item.

The following paragraph is added after the fourth paragraph:

The accepted quantity of Abandoning Existing Manhole Catch basin will be paid for at the contract unit bid price each, which price shall include all work, materials, labor and equipment. Removing, transporting and stacking the frames and grates/covers will be paid for separately, but shall be incidental to the Abandoning Existing Manhole or Catch Basin item.

Payment will be made under:

<u>Pay Item</u>		<u>Pay Unit</u>
202.15	Removing Manhole or Catch Basin	Each
202.151	Abandoning Existing Manhole or Catch Basin	Each

SPECIAL PROVISION

SECTION 202

REMOVING STRUCTURES AND OBSTRUCTIONS

(Removing Existing Pipe)
(Abandoning Existing Pipe)

202.01 Description

The following paragraphs are added:

This work shall consist of removing wholly or in part, and satisfactory disposing of all designated pipe to be removed and abandoning existing pipes in places as designated as part of the contract documents.

The following Subsection is added:

202.052 Removing Existing Pipe

When an existing pipe not part of the proposed project is within 10-feet as horizontally measured, of a proposed pipe, Contractor shall remove wholly or in part, existing pipe as indicated within contract documents. Contractor shall backfill and compact, level with adjacent grade, entire void space with material meeting the gradation of gravel borrow, unless area is subject to other improvements; ie. pavement section, structure, etc.

Add the following section:

202.053 Abandoning Existing Pipe

As designated on the plans or as directed by the Resident, existing pipes shall be abandoned by installing a cap or masonry plug on the downgradient outlet of the pipe and completely filling with flowable fill meeting the requirements of Special Provision 602. Once the pipe is completely filled, a cap or masonry plug shall be installed on the upstream end of the pipe.

202.07 Method of Measurement

The following paragraphs are added:

Removing Existing Pipe shall be measured by the length in linear feet along the centerline of the pipe removed.

Abandoning Existing Pipe shall be measured by the length in linear feet along the centerline of the pipe abandoned.

202.08 Basis of Payment

The following are added after the last paragraph:

Payment for Removing Existing Pipe will be made at the contract unit price per linear foot, which price shall include all work, materials, labor, and equipment to satisfactorily perform the work.

Payment for Abandoning Existing Pipe will be made at the contract unit price per linear foot, which price shall include all work, materials, labor, and equipment to satisfactorily perform the work.

Payment will be made under:

<u>Pay Item</u>		<u>Pay Unit</u>
202.16	Removing Existing Pipe	Linear Foot
202.161	Abandoning Existing Pipe	Linear Foot

SPECIAL PROVISION

SECTION 202

REMOVING STRUCTURES AND OBSTRUCTIONS

(Removing Pavement Surface)

202.01 Description

The following sentence is added:

This work shall also consist of removing the surface of the bituminous concrete pavement to the depth, width, grade, and cross section as shown on the Plans or as approved by the Resident.

The following Subsection is added:

202.061 Removing Pavement

The equipment for removing the bituminous surface shall be a power-operated milling machine or planer capable of removing the bituminous concrete pavement to the required depth. The milling machine shall be capable of accurately establishing profile grades by referencing from a floating straight edge, a minimum of 50 feet. The equipment shall also have an effective means for removing excess material from the surface and for preventing accidents from flying material in compliance with Subsection 105.2.45, Compliance with Health and Safety Laws.

All pavement grindings shall be disposed of by the Contractor off of the turnpike right-of-way in accordance with the Maine Department of Environmental Protection Solid Waste Management Requirements.

SPECIAL PROVISION

SECTION 202

REMOVING STRUCTURES AND OBSTRUCTIONS

(Rumble Strips)

202.01 Description

The following sentences are added after the first paragraph:

This work shall consist of cutting a pattern of rumble strips from MM 7.9 to MM 9.6 on the northbound and southbound roadways at the locations shown on the Plans. Rumble strips shall not be placed across ramp openings or on bridges.

The following Subsections are added:

202.065 Rumble Strips

The rumble strips shall not be cut until the Contractor has placed the permanent pavement markings at the required locations.

At proposed rumble strip locations, the bituminous concrete paved surface shall be removed by milling in strips as detailed on the Plans and as directed by the Resident. The pattern will be 80 feet of rumble strips followed by a 20 foot space repeated along the entire length on the outside shoulder. The inside shoulder shall be continuous. The rumble strips shall be normal to the baseline of the roadway on tangent sections and radial on curves. The Contractor shall be responsible for the layout of the rumble strips. The milling machines for this type of rumble strip are designed by:

Surface Preparation Technology
81 Texaco Road
Mechanicsburg, PA 17055
Tel. (717) 697-1450

L&C Flashing Barricades
60 Walpole Street
Canton, MA 02021
Tel. (508) 580-6700

Thomas Grinding
110 Fox Lane Southwest
Moore Haven, FL 33471
Tel. (863) 946-1461

The milling machine shall be equipped with a 20 foot pointer to provide longitudinal grade control.

202.07 Method of Measurement

The following paragraph is added:

Rumble Strips will be measured by the actual number cut, completed and accepted.

Layout of rumble strips, disposal of milled bituminous pavement and roadway cleanup will not be measured separately for payment, but shall be incidental to this item.

202.08 Basis of Payment

The following sentences are added:

Rumble Strips will be paid for at the Contract unit price per each, which price shall be full compensation for all labor, materials, equipment and incidental items of work for a complete installation.

Payment will be made under:

<u>Pay Item</u>		<u>Pay Unit</u>
202.205	Rumble Strips - Shoulder	Each

SPECIAL PROVISIONSECTION 203EXCAVATION AND EMBANKMENT

(Clay Borrow)

203.01 Description

The following sentence is added:

This work shall include furnishing, placing, grading and densifying clay borrow as shown on the Plans or as approved by the Resident.

203.02 Materials

The following sentence is added:

Clay borrow shall meet the following requirements:

Sieve Size	Max % Passing by Weight
1/2"	100
no.10	95-100
no.40	90-100
no.60	85-100
no.100	75-100
no.200	50-100

The clay material shall have a maximum permeability of 1.0 e-5 cm/s.

203.04 General

The following paragraph is added:

Clay borrow shall be placed and graded to a uniform slope as shown on the Plans. Densification shall be achieved with an approved manually-operated power compactor or as directed by the Geotechnical Consultant.

203.18 Method of Measurement

The following sentence is added:

Clay Borrow shall be measured by the cubic yard complete and accepted in place.

203.19 Basis of Payment

The following sentences are added:

Clay Borrow will be paid for at the Contract unit price per cubic yard which shall be full compensation for all labor, materials, equipment, and incidentals necessary to complete the work.

Payment will be made under:

<u>Pay Item</u>		<u>Pay Unit</u>
203.245	Clay Borrow	Cubic Yard

SPECIAL PROVISIONSECTION 203EXCAVATION AND EMBANKMENT

This Section is amended as follows:

All references to “waste storage areas” shall be deleted.

203.01 Description

The following paragraph is added:

This work shall consist of cutting, removing and disposing of the full depth of existing bituminous concrete pavement within the limits of full depth pavement excavation as shown on the Plans or as approved by the Resident. The pavement shall be sawcut to the full depth of pavement at the limits of the excavation to provide a clean, vertical cut surface.

203.04 General

The third paragraph is deleted and replaced with the following:

There are no approved waste storage areas or waste areas within the Project limits. Unsuitable materials shall be disposed of off-site in accordance with Subsection 203.06.

Any temporary earth support required to install or remove drainage structures and utilities and support existing or proposed utilities will not be measured separately for payment, but shall be incidental to the Excavation items.

All excavations shall be accomplished in accordance with the applicable OSHA Standards. The Resident reserves the right to request the Contractor to prepare an excavation plan. This plan shall include, but not necessarily be limited to, the limit and depth of excavation, side slope, shoring, trench box and utility support.

203.10 Embankment Construction - General

The thirteenth and fourteenth paragraphs are deleted and replaced with the following:

All portions of the embankment shall be compacted in accordance with the designated embankment compaction requirements specified for the Project.

The existing slopes should be benched as shown on the drawings prior to placing additional fill. Embankment fill should be placed in lifts which extend laterally beyond the limits of the design side slopes such that the specified degree of compaction is achieved within the limits of the completed embankment. The slopes should then be trimmed back to design dimensions.

203.11 Construction of Earth Embankment - Layer Method

The second, third, and fourth paragraphs are deleted and replaced with the following:

Layers shall be placed in lifts not to exceed 12 inches after compaction. Common borrow shall be compacted using vibratory compaction equipment to 92 percent of the material's maximum dry density as determined by ASTM D-1557. The compacted material shall appear firm and stable. Strict moisture control shall be utilized by the Contractor when using a cohesive fill material and the moisture content of the compacted material should not exceed four percent above the material's optimum moisture content.

The first sentence of the fourth paragraph is amended as follows:

Satisfactory compaction of granular borrow is defined as not less than 95 percent of the maximum density.

203.12 Construction of Earth Embankment with Moisture and Density Control

The last sentence of the second paragraph is amended as follows:

Each granular borrow layer placed with controlled moisture shall be compacted to not less than 95 percent of the maximum density.

The following paragraph is added:

Common borrow shall be placed in lifts not to exceed 12 inches after compaction. Common borrow shall be compacted using vibratory compaction equipment to 92 percent of the material's maximum dry density as determined by ASTM D-1557. The compacted material shall appear firm and stable. Strict moisture control shall be utilized by the Contractor when using a cohesive fill material and the moisture content of the compacted material should not exceed four percent above the material's optimum moisture content.

203.16 Winter Construction of Embankments

The word "core" is deleted from the first and second sentences in the first paragraph.

203.18 Method of Measurement

Any reference to borrow will be deleted from the first paragraph.

The pay quantity of common borrow and granular borrow shall be 115 percent of the compacted quantity measured in place.

The following sentence is added:

There will be no additional payment for the required excavation plan, and costs shall be incidental to the Excavation items.

SPECIAL PROVISION

SECTION 203

EXCAVATION AND EMBANKMENT

(Rock Excavation)

203.04 General

The following paragraphs are added:

The quantity of rock excavation is approximate and based on a subsurface exploration program. The exploration locations are illustrated on the Plans. The actual limits of ledge shall be determined by probing without the removal of the overburden or by cross section after the removal of the overburden. The Contractor shall propose a method of verifying the quantities to the Resident for approval.

203.19 Basis of Payment

The following paragraphs are added:

The Contractor shall not be compensated for any additional costs associated with verifying quantities by the method approved by the Resident. The Contractor shall be compensated for the actual quantity of ledge excavated at the unit price submitted. No unit price adjustment will be considered if the actual rock excavation quantity differs from the estimated quantity.

SPECIAL PROVISION

SECTION 206

STRUCTURAL EXCAVATION

206.02 Construction Methods

The following paragraphs are added:

There are no approved waste storage areas or waste areas within the Project limits. Unsuitable materials shall be disposed of off-site in accordance with Subsection 203.06.

SPECIAL PROVISION

SECTION 304

AGGREGATE BASE AND SUBBASE COURSE

303.04 Shaping, Compacting and Stabilizing

The following paragraph was added:

Once compaction is complete, the Contractor shall perform a plate load test on the subbase material for the ORT slabs. Perform one test per slab in accordance with ASTM D1196M. The subgrade must achieve a minimum subgrade modulus of at least 250 pci. Provide the test results to the Engineer for approval before placing the concrete.

304.07 Basis of Payment

The following paragraph was added:

Performing plate load tests on the subbase for the ORT slabs will not be measured separately for payment, but shall be incidental to pay item 304.14 listed below.

SPECIAL PROVISIONSECTION 401HOT BITUMINOUS PAVEMENT

(HMA using Hydrated Lime)

The following sections of Section 400 have been revised with following additional requirements.

401.01 Description

The Contractor shall compose Hot Mix Asphalt (HMA) Pavement with aggregate, Performance Graded Asphalt Binder (PGAB), hydrated lime, and mineral filler if required. Hydrated Lime shall be utilized in all mixtures so denoted in Special Provision 403 - Hot Mix Asphalt Pavement.

401.02 Materials

Materials shall meet the requirements specified.

Hydrated Lime

AASHTO 216

401.03 Composition of Mixtures

The Contractor shall compose the Hot Mix Asphalt Pavement with aggregate, Performance Graded Asphalt Binder (PGAB), hydrated lime and mineral filler if required. HMA shall be designed and tested according to AASHTO R35 and the volumetric criteria in Table 1. The Contractor shall size, uniformly grade, and combine the aggregate fractions in proportions that provide a mixture meeting the grading requirements of the Job Mix Formula (JMF).

Hydrated lime shall be used in all HMA at a rate of one percent (1%) by weight of the total dry aggregate including RAP aggregate, if used. The Contractor shall obtain a shipping ticket for each shipment of hydrated lime. The Contractor shall provide the Resident with a copy of each shipping ticket from the supplier, including the date, time and weight of hydrated lime shipped and used in HMA production. The Contractor shall submit a material data sheet for the hydrated lime to the Resident for approval.

The Contractor shall provide the following information with the proposed JMF:

- Material Safety Data Sheets (MSDS) for hydrated lime
- Supplier and source for Hydrated Lime

401.13 Preparation of Aggregates

The Contractor shall add water to the aggregates as required to maintain a minimum total aggregate moisture content of 3 percent. The Contractor shall mix the lime uniformly with the aggregate before introducing the aggregate into the dryer or dryer drum. Hydrated lime introduction systems must be controlled by a proportioning device to the amount required on the JMF plus or minus 0.1% of the target.

The Contractor shall add lime to the aggregate by one of the following methods:

- A. The Contractor shall add lime to the combined cold feed aggregate using an enclosed in-line cold feed mechanical pugmill mixer. The Contractor shall use a twin-shaft, continuous mixing pugmill with mixing paddles to thoroughly blend the lime with the aggregate. The Contractor shall adjust the retention time of the mixture in the pugmill so no unmixed lime is visible after the lime and aggregate exit the pugmill.
- B. The Contractor shall add lime to the produced aggregates during stockpiling using a pugmill. The Contractor shall distribute the lime per the stockpile ratios stated in the asphalt concrete mix design. A minimum moisture content of 2 percent by dry weight for coarse aggregate and 4 percent by dry weight for fine aggregate is required at the time the aggregates and lime are mixed. The Contractor shall marinate treated aggregate in stockpiles from 24 hours to 60 days before using in asphalt concrete mix. Do not use aggregate marinated longer than 60 days.
- C. The Contractor shall add lime to the combined cold feed aggregate by introducing the lime between aggregate layers as the aggregate flows from the cold feed bins. The Contractor shall thoroughly mix the lime and aggregate on the conveyor belt. The Contractor shall provide a lime introduction system so that no unmixed lime is visible before the lime and combined aggregate enter the drum.
- D. Other methods of hydrated lime introduction as approved by the Authority.

The cold storage for hydrated lime shall be a separate bulk storage bin with a vane feeder or other approved feeder system which can be readily calibrated. The system shall provide a means for convenient sampling of the hydrated lime additive and verifying the quantity of lime dispensed. If the hydrated lime is to be introduced directly into the plant then the additive equipment shall be synchronized with the cold feed controls to operate concurrently with the cold feed operation. The system will be configured to automatically adjust the hydrated lime feed to variations in the cold aggregate feed. The hydrated lime system shall have out-of-tolerance sensing ability by weight, and have a means to indicate the out-of-tolerance condition.

401.14 Mixing

Hydrated lime shall be added into the HMA aggregate mixture prior to the aggregate blend mixing with the PGAB. Aggregate feed rate, or pugmill mixing times shall be adjusted to ensure complete blending of Hydrated Lime and aggregate before the PGAB is added.

401.18 Quality Control

The Contractor shall provide a written supplement to the project specific QCP outlining the proposed methods of adding and mixing the hydrated lime for approval by the Authority. This written summary shall also provide information describing how the Contractor will perform quality control on the addition of hydrated lime, specifically the method of introduction and how the lime use will be measured to assure that the specified percentage is consistently added, and appropriately mixed. The supplemental QCP covering hydrated lime introduction shall be provided to the Authority at least one week prior to the prepave meeting.

SPECIAL PROVISIONSECTION 401HOT MIX ASPHALT PAVEMENT

Section 401 of the Maine Turnpike Authority 2016 Supplemental Specifications is modified as follows:

401.01 Description

The following paragraph is added:

A Quality Control Plan(QCP) is required.

401.02 Materials

Section 401.02 is deleted in its entirety and replaced with the following:

Aggregates for HMA Pavements Coarse Aggregate and fine aggregate for HMA pavements shall be graded such that when combined in the proper proportions, including filler if required, the resultant blend will meet the composition of mixture for the type of pavement specified. Materials shall meet the requirements specified in Section 700 – Materials:

Asphalt Cement	702.01
Aggregates for HMA Pavement	703.07
RAP for HMA Pavement	703.08
HMA Mixture Composition	703.09

Surface HMA Coarse aggregate: The material retained on the No. 4 sieve, shall consist of angular fragments obtained from crushed quarry stone and be free of dirt or other objectionable materials. Coarse aggregate shall have a Micro-Deval value of 16.0 percent or less as determined by AASHTO T 327. The crushed stone shall have a maximum of 1.5% material finer than the No. 200 mesh when tested in accordance with AASHTO T-11. Flat and elongated particles shall not exceed a maximum of 8% at a 5:1 ratio in accordance with ASTM D-4791. Coarse aggregate angularity shall be a minimum of 95/90 in accordance with AASHTO T-335.

Surface HMA Fine aggregate: The material passing the No. 4 sieve, shall be crushed manufactured sand free from dirt, clay balls, or other objectionable material. Natural sand may be incorporated into the mix at a rate no greater than 13 percent by weight of total aggregate. The unconfined void content of the fine aggregate blend shall be a 45 minimum value when tested in accordance with AASHTO T-304, method A. AASHTO T-176 sand equivalent value shall be 45 minimum.

Asphalt Low Modulus Joint Sealer: Asphalt Low Modulus Joint Sealer shall be a modified asphalt and rubber compound designed for sealing and improving the strength and performance of the base asphalt cement and shall conform to ASTM D6690 Type IV and the following specifications:

Cone Penetration	90-150
Flow @ 60°C [140°F]	3.0mm [1/8 in] max
Bond, non-immersed	Three 12.7mm [1/2 in] specimens pass 3 cycles @ 200% extension @ -29°C [-20°F]
Resilience, %	60 min
Asphalt Compatibility, ASTM D5329	pass*

* There shall be no failure in adhesion, formation of any oily exudate at the interface between the sealant and asphaltic concrete or other deleterious effects on the asphaltic concrete or sealant when tested at 60°C [140°F].

The Contractor shall provide the Resident or authorized representative with a copy of the material manufacturer's recommendations pertaining to heating, application, and reheating prior to the beginning of operations or the changing of materials.

Section 401.03 Composition of Mixtures

Section 401.03 is deleted in its entirety and replaced with the following:

The Contractor shall compose the Hot Mix Asphalt Pavement with aggregate, Performance Graded Asphalt Binder (PGAB), and mineral filler if required. HMA shall be designed and tested according to AASHTO R35 and the volumetric criteria in Table 1. The Contractor shall size, uniformly grade, and combine the aggregate fractions in proportions that provide a mixture meeting the grading requirements of the Job Mix Formula (JMF). The Contractor may use a maximum of 15 percent reclaimed asphalt pavement (RAP) in any base, binder, surface, or shim course, unless otherwise noted. Current MaineDOT approved designs will be allowed on local roads.

The Contractor shall submit a job mix formula (JMF) developed for each specified mixture at least 30 days prior to placement.

The JMF shall establish a single percentage of aggregate passing each sieve size within the limits shown in Subsection 703.09. The mixture shall be designed and produced, including all production tolerances, to comply with the allowable control points for the particular type of mixture as outlined in Subsection 703.09. The JMF shall state the original source, gradation, and percentage to be used of each portion of the aggregate and mineral filler if required. It shall also state the proposed PGAB content, the name and location of the refiner, the supplier, the source of PGAB submitted for approval, the type of PGAB modification if applicable, and the location of the terminal if applicable.

In addition, the Contractor shall provide the following information with the proposed JMF:

- Properly completed JMF indicating all mix properties (Gmm, VMA, VFB, etc.).

- Stockpile Gradation Summary.
- Individual aggregate consensus properties
- Design Aggregate Structure Consensus Property Summary.
- Design Aggregate Structure Trial Blend Gradation Plots (0.45 power chart).
- Trial Blend Test Results for at least three different aggregate blends.
- Selected design aggregate blend.
- Test results for the selected design aggregate blend at a minimum of three binder contents.
- Test results for final selected blend compacted to N_{max} .
- Specific Gravity and temperature/viscosity charts for the PGAB to be used.
- Recommended mixing and compaction temperatures from the PGAB supplier.
- Material Safety Data Sheets (MSDS) For PGAB.
- Asphalt Content vs. Air Voids trial blend curve.
- Test report for Contractor's Verification sample.
- Summary of RAP test results (if used), including count, average and standard deviation of binder content and gradation.

At the time of JMF submittal, the Contractor shall identify and make available the stockpiles of all proposed aggregates at the plant site. There must be a minimum of 150 ton for stone stockpiles, 75 ton for sand stockpiles, and 50 ton of blend sand before the Authority will sample. The Authority shall obtain samples for laboratory testing. The Contractor shall also make available to the Authority the PGAB proposed for use in the mix in sufficient quantity to test the properties of the asphalt and to produce samples for testing of the mixture. Before the start of paving, the Contractor and the Authority shall split a production sample for evaluation. The Contractor shall test its split of the sample and determine if the results meet the requirements. If the results are found to be acceptable, the Contractor will forward their results to the Authority's Lab, which will test the Authority's split of the sample. The results of the two split samples will be compared and shared between the Authority and the Contractor. If the Authority finds the mixture acceptable, an approved JMF will be forwarded to the Contractor. The Authority will then notify the Contractor that paving may commence. The first day's production shall be monitored, and the approval may be withdrawn if the mixture exhibits undesirable characteristics such as checking, shoving or displacement. The Contractor shall be allowed to submit aim changes within 24 hours of receipt of the first Acceptance test result for an individual JMF. Adjustments will be allowed of up to 2% on the percent passing the 2.36 mm sieve through the 0.075 mm and 3% on the percent passing the 4.75 mm or larger sieves. Adjustments will be allowed on the %PGAB of up to 0.2 percent. Adjustments will be allowed on GMM of up to 0.010.

The Contractor shall submit a new JMF for approval each time a change in material source or materials properties is proposed. The same approval process shall be followed. The cold feed percentage of any aggregate except natural sand may be adjusted up to 10 percentage points from the amount listed on the JMF, however no aggregate listed on the JMF shall be eliminated. Natural sand may be adjusted up to 5 percent from the amount listed on the JMF but shall not exceed 13% by weight of total aggregates. The cold feed percentage for RAP may be reduced up to five percentage points from the amount listed on the JMF and shall not exceed the percentage of RAP approved in the JMF or for the specific application.

TABLE 1
VOLUMETRIC DESIGN CRITERIA

Design ESAL's (Millions)	Required Density (Percent of G _{mm})			Voids in the Mineral Aggregate (VMA)(Minimum Percent)					Voids Filled with Binder (VFB) (Minimum %)	Fines/Eff. Binder Ratio
				Nominal Maximum Aggregate Size (mm)						
	N _{initial}	N _{design}	N _{max}	25	19	12.5	9.5	4.75		
10 to <30	≤89.0	96.0	≤98.0	13.0	14.0	15.0	16.0	16.0	65-80*	0.6-1.2

* For 9.5 mm nominal maximum aggregate size mixtures, the maximum VFB is 82.

* For 4.75 mm nominal maximum aggregate size mixtures, the maximum VFB is 84.

* For 4.75mm nominal maximum aggregate size mixtures, the Fines/Effective Binder Ratio is 0.6-1.4

As part of the JMF submittal, there are Hamburg Wheel Tracker requirements, the Contractor shall provide the Authority the test results in accordance with AASHTO T324. The results shall be generated by a third party independent testing laboratory as approved by the Authority. The test results shall meet the requirements of Table 1A

TABLE 1A
HAMBURG WHEEL TRACKER REQUIREMENTS

Specified PG Binder Grade	Test Temperature (°C)	Maximum Rut Depth (mm)	Minimum Number of Passes	Minimum Allowable SIP*
64-28	45	12.5	20,000	15,000
64E-28	45	8.0	20,000	15,000

* As calculated by the most recently published version of the Maine DOT HWT worksheet, which is available online at <http://www.maine.gov/mdot/contractors/publications/>

Section 401.091 Material Transfer Vehicle (MTV)

The fourth paragraph shall be deleted and replaced with:

The MTV shall be designed so that the mix receives additional mixing action.

Section 401.165 Longitudinal Joint Density

The first paragraph shall be deleted and replaced with:

When noted in Special Provision Section 403, the Authority will measure the pavement density of longitudinal joints between adjoining mainline travel lanes in both the unconfined and confined condition as determined by the days paving operation.

The eighth paragraph shall be deleted and replaced with:

The minimum density of the completed pavement shall be 91.5 percent of the theoretical maximum density obtained. Two consecutive failing tests shall result in production shut down. Prior to resuming paving operations, the Contractor quality control unit shall satisfy the Authority that the paving operation will produce joint densities in compliance with the Specifications.

The eleventh paragraph and associated table shall be deleted and replaced with:

Payment reduction will be applied to each subplot that has a density lower than 91.5% as outlined below.

PERCENT COMPACTION	PERCENT PAY
91.5 or greater	100
90.0 to 91.4	95
89.9 or less	90

Section 401.17 Joints

The fourth paragraph shall be deleted and replaced with:

When required by Special Provision Section 403, Mainline Longitudinal joints shall be constructed as notched-wedge joint and constructed in a manner that will best ensure joint integrity.

Section 401.191 Inspection/Testing

In paragraph nine delete and replace Item #8 with:

- 8. Secure High Speed Internet Access

SPECIAL PROVISIONSECTION 403HOT BITUMINOUS PAVEMENT403.01 Description

The following paragraph is added:

This work shall also consist of the construction, maintenance and removal of all temporary bituminous ramps at locations as shown on the Plans or as directed by the Resident.

403.02 General

The following paragraph is added:

The Contractor shall compose the Hot Mix Asphalt Pavement with aggregate, Performance Graded Asphalt Binder (PGAB), and mineral filler if required. The Performance Graded Asphalt Binder (PGAB) shall be polymer modified as detailed in this special provision and shall conform to the requirements of AASHTO M 320. The PG64E-28 Binder shall contain a minimum of 2.5% Styrene-Butadiene-Styrene (SBS) polymer {BWT} in a homogeneous blend. The stability of the modified binder shall be verified in accordance with ATSM D7173 using the Dynamic Shear Rheometer (DSR). The DSR $G^*/\sin(\delta)$ results from the top and bottom sections of the ATSM D7173 test shall not differ by more than 10%. The results of ASTM D7173 shall be included on the Certified Test Report. The binder shall meet the requirements of AASHTO M 332 (including Appendix X1).

403.03 Construction

The following paragraphs are added:

All areas which have been milled or overlaid shall have a minimum length temporary ramp constructed as determined by the Resident at the milled or overlaid limits prior to opening the roadway to traffic. Temporary ramps shall be constructed using the same material as being placed on that day or as directed by the Resident. All temporary ramps are to be constructed on a sand joint. The Contractor shall be responsible for all repairs and maintenance required for the temporary ramps.

The Contractor shall be responsible for the layout of the longitudinal centerline between the travel lanes.

The sand and loose debris adjacent to the median guardrail shall be removed and disposed of by the Contractor off of Turnpike property.

The forty-five degree pavement safety wedge shall be provided along all longitudinal paving joints and shall be incidental to the 403 pay items.

A minimum test strip of 100 tons placed at a nominal depth of 1 ½ inches, full lane width, shall be required. It shall be evaluated under testing requirements for mix volumetric and

density. The exact location will be identified by the Authority. Prior to placement of the test strip, a leveling course (Item 403.211) shall be placed at the chosen location. A fog coat of Item 409.15, Bituminous Tack Coat, shall be applied to the level course prior to the placement of the HMA surface course, payment to be made under the 409.15 pay item. The test strip will be excluded from the remainder of the projects' QA analysis. The Contractor shall notify the Authority at least 48 hours in advance of placing the test strip. The test strip is intended to allow the Contractor to establish a method of compaction and adjust plant settings prior to mainline plant production.

403.04 Method of Measurement

The following paragraphs are added:

The construction and removal of temporary ramps on sand joints, and maintaining the ramps will not be measured separately for payment, but shall be incidental to Items 403.

The removal of sand and loose debris will not be measured separately for payment, but shall be incidental to paving items.

SPECIAL PROVISIONSECTION 403HOT MIX ASPHALT PAVEMENT
(Pavement Table)

Course	HMA Grading	Item Number	Total Thickness	No. of Layers	Complimentary Notes
--------	-------------	-------------	-----------------	---------------	---------------------

Northbound and Southbound Mill and Pave

Surface	12.5mm	403.2081	1.5"	1	A,C,F,G,H,I,J,K,L,M,N
Shim	4.75	403.211	½"	1	B,F,J,L,N

Northbound and Southbound Shim and Pave

Surface	12.5mm	403.2081	1.5"	1	A,C,F,G,H,I,J,K,L,M,N
Binder	12.5mm	403.213	1.5"	1	B, F,J,L,N
Base	19.0 mm	403.207	Varies	2 ½" max. lift	B, F,J,L,N
Shim	4.75mm	403.211	Varies 0" to 1½"	1	B,F,J,L,N
Shim	12.5 mm	403.211	Varies 1 ½" to 3"	1	B,F,J,L,N

Northbound and Southbound Full Depth Construction and Full Depth Pavement Removal

Surface	12.5mm	403.2081	1.5"	1	A,C,F,G,H,I,J,K,L,M,N
Binder	12.5mm	403.213	1.5"	1	B,F,J,L,N
Base	19.0 mm	403.207	7.5"	3	B,F,J,L,N

Access Road

Surface	12.5mm	403.208	2"	1	B,F,J,L,N
Binder	12.5mm	403.213	2"	1	B,F,J,L,N

Parking

Surface	12.5mm	403.208	2"	1	B,F,J,L,N
Binder	12.5mm	403.213	2"	1	B,F,J,L,N
Base	19.0 mm	403.207	2 ½"	1	B,F,J,L,N

COMPLEMENTARY NOTES

- A. The required PGAB for this mixture shall be **64E-28**.
- B. The required PGAB for this mixture shall be **64-28**.
- C. A maximum of 15 percent RAP may be used.
- D. RAP may not be used.
- E. The Maine DOT will conduct the job mix verification. The aggregate qualities shall meet the design traffic level of 3 to <10 million ESALS for mix placed under this contract. The design verification, Quality Control, and Acceptance tests for this mix will be performed at **XX gyrations**. (N design) Minimum and Maximum PGAB content shall not apply.
- F. The MTA will conduct the job mix verification. The aggregate qualities shall meet the design traffic level of 10 to <30 million ESALS for mix placed under this contract. The design verification, Quality Control, and Acceptance tests for this mix will be performed at **75 gyrations**. (N design)
- G. A material transfer vehicle (MTV) shall be used for the placement of Hot Mix Asphalt wearing surface on all roadways including acceleration and deceleration lanes and all ramps.
- H. Joints shall be constructed as the “notched wedge” type in accordance with Subsection 401.17.
- I. Joint density will be measured in accordance with Subsection 401.165.
- J. Tack coat shall be applied between all layers of pavement at a rate of 0.04 G/SY.
- K. PGAB shall conform to the provisions of 403.02 – Polymer Modified PGAB for HMA
- L. The Contractor shall furnish a quality control technician equipped with an approved densometer to ensure density requirements are met.
- M. Hydrated Lime shall be incorporated into the mixture.
- N. No vehicular loads shall be permitted on newly completed pavement until adequate stability has been attained and the material has cooled sufficiently to prevent distortion or loss of fines. The newly paved area may be opened to traffic after the internal temperature of the pavement has cooled to 120° F. The Resident will test the internal temperature of the pavement and shall be the sole judge as to the opening to traffic. The period of time before opening to traffic may be extended at the discretion of the Resident. The lane closure may not be removed until the internal temperature has cooled to 120° F.

SPECIAL PROVISIONSECTION 409BITUMINOUS TACK COAT409.02 Bituminous Material

This Subsection is deleted and replaced with the following:

Bituminous material shall conform to the Specifications for Emulsified Asphalt RS-1h, or RS-1 of the AASHTO Designation M-140.

409.05 Equipment

Add “or as determined by the Resident”, after the words “gal/yd²” in the fourth line of the second paragraph of this Subsection.

409.06 Preparation of Surface

The following paragraph is added:

All existing pavement and shoulder areas on which bituminous concrete mixtures are to be placed shall receive a tack coat. The surface area where the tack coat is to be applied shall be dry and cleaned of all dirt, sand, and loose material. Cleaning shall be accomplished by use of revolving brooms or mechanical sweepers. Undesirable material not removed by the above means shall be cleaned by hand sweeping or scraping, or a combination of both. Small areas otherwise inaccessible may be swept with hand brooms. The tack coat shall be applied only when the existing surface is dry.

409.08 Method of Measurement

The following paragraphs are added:

Measurement will be based on delivery slips made out in duplicate by the Contractor and signed by the Resident, or his representative, at the point of delivery. One of these slips shall be retained by the Resident and one by the Contractor. Delivery slips shall be furnished by the Contractor and shall provide space for identifying the vehicle and driver, for stating the volume of material carried, the source of the material, the date, and the Resident or his representative's signature.

Material included in the delivery slips and not used or rejected shall be deducted from the amount being measured for payment. Each day's delivery slips shall be reconciled by the Contractor and the Resident within 24-hours.

Cleaning of the surface area where tack coat is to be applied shall be incidental to Item 409.15, Bituminous Tack Coat - Applied.

409.09 Basis of Payment

The following pay items are added:

<u>Pay Item</u>		<u>Pay Unit</u>
409.15	Bituminous Tack Coat – Applied	Gallon

SPECIAL PROVISIONSECTION 419SAWING AND SEALING JOINTS IN BITUMINOUS PAVEMENT

(Sawing Bituminous Pavement)

419.01 Description

This work consists of sawing bituminous concrete pavement as shown on the Plans, as specified herein or as approved by the Resident.

419.02 General

The bituminous concrete pavement to be sawed shall be accurately marked before cutting. The marking shall be in accordance with the locations as shown on the Plans or as approved by the Resident. Cutting shall be with an approved power driven saw with an abrasive blade.

Unless otherwise noted or directed, the sawcut shall be vertical, a minimum of 3/8 inch wide, and extend to the depth as shown on the Plans.

Residue or debris from the sawing operation shall be removed immediately and legally disposed of by the Contractor.

419.03 Method of Measurement

Sawing Bituminous Pavement will be measured by the linear foot of pavement actually cut and accepted. No additional payment will be made for variations in the pavement thickness.

419.04 Basis of Payment

Sawing Bituminous Pavement will be paid for at the Contract unit price per linear foot which shall be full compensation for all materials, tools, equipment labor, and all incidentals necessary for the completion of the work to the satisfaction of the Resident. The disposal of sawcut residue shall be incidental to this item.

Payment will be made under:

<u>Pay Item</u>	<u>Pay Unit</u>
419.30 Saw Cutting Bituminous Pavement	Linear Foot

SPECIAL PROVISIONSECTION 502STRUCTURAL CONCRETE

This specification amends Maine Turnpike Authority Supplemental Specification 502.

502.01 Description

The following is added:

This work shall consist of furnishing and placing Portland Cement Concrete for structures and incidental construction in accordance with these Specifications and in conformity with the lines, grades and dimensions shown on the Plans.

502.03 Materials

The following paragraph is added:

Waterstops for cast-in-place portions of the tunnel shall consist of the following:

- 1) Hydrophilic waterstops (at construction joints) shall be non-bentonite, modified chloroprene rubber. The waterstop shall have a delay coating to inhibit initial expansion due to moisture present in fresh concrete. Install in accordance with manufacturer's requirements. Hydrophilic waterstops shall be one of the following:
 - a. Hydrotite by Greenstreak, 3400 Tree Court Industrial Blvd., St. Louis, MO 63122, Tel: (800) 325-9504
 - b. Aquafin Waterstop by Aquafin, Inc., 505 Blue Ball Rd. #160, Elkton, MD 21921, Tel: (410) 392-2300
- 2) Dumbbell waterstops (at locations indicated on the Drawings) shall be polyvinylchloride (PVC) and conform to the requirements of United States Army Corp of Engineers Specification CRD C-572. Dumbbell waterstops shall be ribbed centerbulb configuration and be minimum 6" wide. No reclaimed PVC shall be used. Install in accordance with manufacturer's requirements. Dumbbell waterstops shall be one of the following:
 - a. Durajoint PVC waterstop Type 4 by Durajoint Concrete Accessories, 10421 Industrial Drive, Garrettsville, OH 44231, Tel: (800) 833-8308
 - b. Sika Greenstreak PVC waterstop Type 703 as manufactured by Sika
 - c. Sealtight PVC waterstop Type 6316 by W. R. Meadows, 70 Hannant Court, Milton, ON L9T 5C1, Tel: (800) 342-5976
- 3) Dumbbell waterstops without centerbulb (at locations indicated on the Drawings) shall be polyvinylchloride (PVC) and conform to the requirements of United States Army Corp of Engineers Specification CRD C-572. Dumbbell waterstops shall be ribbed and be minimum 6" wide. No reclaimed PVC shall be used. Install in

accordance with manufacturer's requirements. Dumbbell waterstops shall be one of the following:

- a. Durajoint PVC waterstop Type 15 by Durajoint Concrete Accessories, 10421 Industrial Drive, Garrettsville, OH 44231, Tel: (800) 833-8308
- b. Sika Greenstreak PVC waterstop Type 783 as manufactured by Sika

502.04 Shipping and Storage

The following paragraph is added:

Store waterstops under tarps to protect from oil, dirt, sunlight, and premature exposure to water.

502.05 Composition and Proportioning

The following paragraph is added:

Cast-in-Place concrete barrier with a minimum compressive strength of 4,500 psi shall be Class AAA-Deck (without synthetic reinforcement). Synthetic Fiber Reinforcement shall be added to mixes for cash lane roadway concrete structural slabs and ORT concrete slabs in accordance with Special Provision 503 "Synthetic Fiber Reinforcement."

502.0502 Quality Assurance

The first sentence of paragraph A. Surface Tolerance shall be replaced with the following:

Exposed horizontal and sloping portions of toll island concrete, space frame pedestals, barriers, and exposed concrete cash lane structural slabs and ORT slabs will be measured at randomly generated locations within a 10 foot straightedge once per 100 ft².

The following paragraph is added to paragraph C. Plumb and Batter:

Vertical faces of pedestals for space frame posts, canopy columns, and CCTV poles will be measured at a minimum of two faces at right angles to each other.

502.11 Placing Concrete

The following section is added:

H. Sawcut Joints:

Sawcut all joints shown on the Plans at cash lane structural slabs and ORT concrete slabs. Elastomeric joint sealant shall be used to fill sawcuts. The joint sealant supplied shall be an approved two component, elastomeric joint sealant capable of 50 percent joint movement. Both components shall be in liquid form and the combining ratio of components by volume shall be as recommended by the manufacturer. Elastomeric joint sealant shall conform to ASTM C 920.

502.14 Finishing Concrete

The following paragraph is added:

The concrete finish for cast-in-place portions of the tunnel shall be similar to the precast portions as specified in Section 534.17 of the MaineDOT Standard Specifications.

The following shall be added to Table 5:

Concrete ORT and Plaza Roadway Structural Slab Surfaces	3 mm [1/8 in.]
Toll Island Concrete Surfaces	3 mm [1/8 in.]
Cast-in-Place Tunnel	3 mm [1/8 in.]
Utility Pit Surfaces	6 mm [1/4 in.]

The following section shall be added:

F. Broomed Finish:

Provide a broomed finish at cash lane structural slabs and ORT slabs.

502.14 Finishing Concrete Surfaces

The following sentence is added:

Provide a rubbed finish at all exposed concrete surfaces at the toll islands.

502.18 Method of Measurement

Paragraph B of this section shall be replaced with the following:

B. The limits to be used in determining the quantities of the aforementioned structural concrete items will be as follows:

1. Structural Concrete, Space Frame and Overhead Sign Support Structure Pedestals. The limits will be the space frame and overhead sign support structure pedestals from the top of the drilled shaft to the top of the pedestal (match barrier elevations at the median pedestals).
2. Structural Concrete, Canopy Column Foundations. The limits will be the column foundation from the bottom of the spread footing to the top of the footing pedestal (bottom of grout for canopy column base plate).
3. Structural Concrete, ORT Slabs. The limits will be both ORT slabs, each bounded transversely and longitudinally by the extreme ends.
4. Structural Concrete, Plaza Structural Slabs. The limits will be the plaza structural slabs including the toll islands and bounded transversely and longitudinally by the extreme ends or edges of concrete.
5. Structural Concrete, Toll Islands. The limits will be the entire concrete island (within limits of curb), transversely and longitudinally. Concrete ramparts, bumpers, curtain walls placed atop the plaza islands, island slab, structural slab within island, concrete

within Toll Island Type C placed against traffic barrier, are included in this item. Cast-in-place concrete sections above precast tunnel stair case segments are also included.

6. Structural Concrete, Utility Pits. The limits will be the four utility pit walls and bottom slab at each toll island.
7. Structural Concrete, CCTV Pole Foundations. The limits will be the pole foundations from the bottom of the spread footing to the top of the footing pedestal above finished grade.
8. Structural Concrete Rigid Frame Structures[Tunnel] (Cast-in-Place Sections). The limits will be the cast-in-place portions of the tunnel at each tunnel staircase location as shown on the Drawings and the cast-in-place portion of the tunnel adjacent to the toll administration building (i.e., cast-in-place connector tunnel) as shown on the Drawings.

502.19 Basis of Payment

The following is added:

The procurement and installation of the electric conduit and anchorages placed within the concrete pedestals for space frames, overhead sign structures and canopies will not be measured separately for payment, but shall be incidental to the applicable pay items listed below.

All work required for furnishing and installing elastomeric joint sealant, grout, embedded PVC sleeves for conduit and utility pipes, utility pit drains, saw-cutting, closed cell foam, backer rods, and preformed filler will not be measured separately for payment, but shall be incidental to the work provided under the applicable pay items listed below.

Concrete for drilled shafts, reinforcing steel, GFRP reinforcement, and synthetic fiber reinforcement, will be measured and paid for separately.

Precast concrete tunnel and staircase sections will be measured and paid for separately as described in Section 534.

Payment will be made under:

<u>Pay Item</u>	<u>Pay Unit</u>
502.231 Structural Concrete, Space Frame and Overhead Sign Support Structure Pedestals	Cubic Yard
502.233 Structural Concrete, Canopy Column Foundations	Cubic Yard
502.265 Structural Concrete, ORT Slabs	Cubic Yard
502.266 Structural Concrete, Plaza Structural Slabs	Cubic Yard
502.267 Structural Concrete, Toll Islands	Cubic Yard
502.268 Structural Concrete, Utility Pits	Cubic Yard
502.269 Structural Concrete, CCTV Pole Foundations	Cubic Yard
502.28 Structural Concrete, Rigid Frame Structures [Tunnel]	Cubic Yard

SPECIAL PROVISIONSECTION 503REINFORCING STEEL

(GFRP and Synthetic Fiber Reinforcement)

503.01 Description

The first paragraph is amended to read:

This work shall consist of fabrication, delivery and placing glass fiber reinforced polymer (GFRP) reinforcement in accordance with these Specifications and in conformance with the Plans, Supplemental Specifications and Special Provisions.

This work shall also consist of furnishing synthetic macro fiber reinforcement in the concrete cash lane slabs and ORT concrete slabs.

503.02 Materials

The following paragraphs are added:

Materials shall meet the following requirements:

All GFRP reinforcement shall conform to the requirements shown in AASHTO Bridge Design Guide Specifications for GFRP - Reinforced Concrete Bridge Decks and Traffic Railings (November 2009), except as shown on the Plans, and as stated herein. All GFRP reinforcement bar shall be sand coated or both deformed and sand coated. Deforming methods shall be performed during the fabrication process. GFRP reinforcement shall not be deformed in the field.

GFRP bars shall be from one of the following approved manufacturers:

1. Aslan 100 by Hughes Brothers Inc.
2. V-Rod by Pultrall Inc.
3. ComBAR by Schock Bauteile.
4. Mateen-Bar by Sigma Development Group, LLC.

All GFRP bars in the same structural component shall be supplied by the same manufacturer.

Synthetic fibers shall be STRUX 90/40 as manufactured by W. R. Grace & Co. or an approved equal.

Documentation

For all GFRP reinforcement bar used on Authority projects, the bar manufacturer shall furnish the Resident with one hardcopy and one electronic copy of written certifications that GFRP reinforcement meets the requirements of this specification. In addition, the certification shall list the test values and test procedures used to determine the physical properties of the

GFRP reinforcement. Certifications bearing the notarized signature of a responsible authorized representative of the bar manufacturer are required. Each bundle of GFRP reinforcement shall be identified with a corresponding lot number with the lot numbers affixed to each bundle by means of a durable tag.

Provide manufacturer's required lap splice lengths for all bar sizes shown on the Plans.

Repair Material

The material used to repair the cut ends of GFRP reinforcement shall comply with the requirements established by the bar manufacturer.

The following Subsection shall be added:

503.031 Dosage

The dosage rate for synthetic fibers shall be five lbs per cubic yard of concrete.

503.04 Protection of Material

The following paragraphs are added:

Delivery, storage and handling of GFRP reinforcing bars shall be in accordance with these Specifications. Prevent bending, coating with earth, oil, or other material, or otherwise damaging the reinforcement. When handling reinforcement, use equipment to avoid damaging or abrading the bar. Do not drop or drag reinforcement.

GFRP reinforcement shall be stored on skids or other supports a minimum of 12 inches above the ground surface and protected at all times from damage and surface contamination. The storage supports shall be constructed of wood, or other material that will not damage the surface of the reinforcement. Bundles of bars shall be stored on supports in a single layer. Each bundle shall be placed on the supports out of contact with adjacent bundles. Reinforcing bars expected to be stored outdoors for a period in excess of two months, shall be protected from ultraviolet radiation. Prevent exposure of reinforcing to temperatures above 120 degrees Fahrenheit during storage.

All handling of reinforcing bars by mechanical means shall be done by equipment having padded contact areas, or by the use of nylon webbing slings. The use of chains or wire rope slings shall not be allowed, even when used with padding. All bundles of bars shall be lifted with a strong back, spreader bar, multiple supports or a platform bridge to prevent bar-to-bar abrasion from sags in the bundles. Support points during lifting or transporting of bundled reinforcing bars shall be spaced at a maximum of 15 feet, or as required by the manufacturer, whichever is more restrictive.

Bundled bars shall be strapped together with non-metallic or padded straps in a manner to prevent bar-to-bar abrasion due to relative movement between bars.

Bars loaded for transport shall be loaded and strapped down in a manner that will prevent damage from motion and vibration, to the greatest extent possible. Bundles of bent bars shall be

transported strapped to wooden platforms or shall be crated. All individual bundles and layers of bundles shall be separated, and supported by dunnage.

Individual bars shall be handled in a manner that prevents damage due to abrasion or impact, and at no time shall any bar be moved by dragging over any surface, including other reinforcing bars. Sufficient personnel shall be assigned to assure compliance with the above.

For GFRP bars the maximum total visible damage permitted on each linear foot shall not exceed two percent of the surface area in that linear foot of bar. The depth of the permissible damage shall not exceed 0.04 inches. If the visible damage exceeds these requirements, the Contractor shall lap splice a new GFRP bar matching the size of the damaged bar. The new bar shall extend the required lap length on each side of the damaged area.

503.06 Placing and Fastening

The following paragraphs are added:

All reinforcement shall be accurately placed in the positions shown on the Plans and shall be firmly held there during the placing and setting of the concrete. Immediately before placing concrete the reinforcement shall be free from all foreign material which could decrease the bond between the reinforcing and concrete. Such foreign material shall include, but not be limited to: dirt, paint, oil, bitumen and dried concrete mortar.

Reinforcing bars within the formwork shall be secured to prevent movement during concrete placement. The bars must be adequately supported or tied to resist settlement, floating upward, or movement in any direction during concrete placement.

Field bending of GFRP is not allowed.

Field cutting of GFRP will be permitted only with the approval of the Resident. The field cutting shall be with a high speed cutter, fine blade saw, diamond blade or masonry saw. The GFRP bars shall not be shear cut.

Proper distances from the forms shall be maintained by means of stays, blocks, ties, hangers or other approved means. Blocks used for this purpose shall be precast Portland cement mortar blocks of approved shape and dimensions. Chairs may be used for this purpose and, when used, must be GFRP or plastic. The use of pebbles, pieces of broken stone or brick, steel materials, or wooden blocks shall not be permitted. The placing of reinforcement as concrete placement progresses, without definite and secure means of holding the bar in its correct position, shall not be permitted. Reinforcing bars used as support bars and spreader bars shall be the same type used for the main reinforcing.

Bars shall be fastened together at all intersections except where spacing is less than one foot in either direction, in which case, fastening at alternate intersections of each bar with other bars will be permitted providing this will hold all the bars securely in position. This fastening may be plastic or nylon ties only.

Reinforcement shall be inspected and approved by the Resident before any concrete is placed.

503.07 Splicing

The following sentence is added:

Lap splice length for GFRP bars shall be as per manufacture's recommendation.

503.10 Method of Measurement

The first sentence of the first paragraph is amended as follows:

GFRP reinforcing bars shall be measured by the computed number of pounds of reinforcement authorized.

Synthetic fiber reinforcement will be measured by the pound.

503.11 Basis of Payment

This following is added:

<u>Pay Item</u>		<u>Pay Unit</u>
503.18	Glass Fiber Reinforced Polymer (GFRP) Reinforcing Bars, Fabricated and Delivered	Pound
503.19	Glass Fiber Reinforced Polymer (GFRP) Reinforcing Bars, Placing	Pound
503.90	Synthetic Fiber Reinforcement	Pound

The accepted quantity of GFRP reinforcing will be paid for at the Contract unit price per pound for each item involved, completed, and accepted.

SPECIAL PROVISIONSECTION 504STRUCTURAL STEEL

(Space Frame Canopy, Fabricated and Delivered)
(Space Frame Canopy, Erection)
(Space Frame Steel Support Posts and Anchorage Assembly)

504.01 Description

The following paragraphs are added:

This work shall also consist of designing, fabricating and erecting a space frame canopies in accordance with the Plans, these Specifications, and as directed by the Engineer. The space frame canopies shall be fabricated from steel and hot-dipped galvanized after fabrication.

This work shall also consist of fabricating and erecting steel support post systems to support each space frame canopy in accordance with the Plans, these Specifications, and as directed by the Engineer. The steel support post systems shall be fabricated from steel and hot-dipped galvanized after fabrication.

The space frames shall be designed, fabricated and manufactured by one of the following companies, or an approved equal:

- Delta Structures, Inc., 811 Eagle Drive, Bensenville, IL 60106
- Novum Structures, LLC, W126 N8585 Westbrook Crossing, Menomonee Falls, WI 53051
- Gossamer Space Frames, 5622 Research Drive, Ste. B, Huntington Beach, CA 92649

Design of the space frame canopies and steel post support systems shall be in accordance with the Plans, the Specifications, and the AASHTO Standard Specifications for Structural Supports for Highway Signs, Luminaries, and Traffic Signals, 6th Edition, with 2015 Interims. Design calculations, shop drawings, and analysis data shall be stamped by a Professional Engineer licensed in the State of Maine.

Fabrication of the space frame canopies and steel post support systems shall be completed in accordance with Standard Specification Subsections 504.14 through 504.39 with modifications included in this Special Provision.

Erection of the space frame canopy and steel post support system shall be completed in accordance with Standard Specification Subsections 504.40 through 504.56 with modifications included in this Special Provision.

Welding of hollow structural steel posts shall be performed in accordance with AWS D1.1 (latest edition).

504.02 Materials

The following paragraphs are added:

The space frame canopy and steel post support system shall be fabricated from the following:

- Structural steel plates and shapes shall be ASTM A572, Grade 50 and shall meet the requirements of AWS D1.1, Section 4, Part D for CVN testing.
- Hollow Structural Steel (HSS) steel posts shall be ASTM A500, Grade B (Fy = 46 ksi) (minimum)
- Pipes for use in the space frame canopy shall conform to one of the following:
 - ASTM A500, Grade B (Fy = 46 ksi) (minimum)
 - ASTM A53, Grade B.

Anchor rods shall conform to ASTM F1554, Grade 105.

Nuts, washers, and anchor rods shall be hot dip galvanized. Bolts and anchor rods shall be furnished with double nuts and washers. Threaded length shall be in accordance with the details shown.

Materials not specifically covered in the Plans and Specifications shall be in accordance with the AASHTO Standard Specifications for Structural Supports for Highway Signs, Luminaries, and Traffic Signals, 6th Edition, with 2015 Interims, and shall be subject to approval by the Engineer.

504.03 Drawings

The first sentence of the first paragraph is deleted and replaced with the following:

The Contractor shall submit design computations, fabrication drawings, erection plans and other necessary working drawings in accordance with Subsection 105.07, Working Drawings.

This Subsection is amended by the addition of the following:

When structural steel erection is to take place over travel ways, the Contractor shall submit a structural steel erection plan stamped by a Professional Engineer licensed in the State of Maine. The erection plan shall include the number and location of crane(s), the weight of the pick, crane capacities, bracing locations and all other pertinent information needed to demonstrate the structural steel can be safely erected and assembled.

504.04 Facility Requirements

This Subsection is deleted and replaced with the following:

Fabricate steel in a facility that participates in the AISC Quality Certification Program and is designated an AISC-Certified Plan, Category BU.

All materials fabricated in a shop that does not have the aforementioned certification will be rejected. Work shall not be subcontracted to a non-certified facility, except that machining operations may be performed in non-certified facilities, as approved by the Fabrication Engineer.

504.06 Inspection

The second paragraph is deleted and replaced with the following:

Quality Control and all testing of welds shall be certified by a qualified laboratory engaged by the Contractor and approved by the Engineer. The Contractor shall forward the certifications to the Engineer and shall pay for all costs of weld inspection and certification as herein specified.

The Engineer reserves the right to inspect, by nondestructive testing techniques, all welds and adjacent base metal as deemed warranted. All such additional testing shall be paid for by the Authority.

504.14 Materials for Bridges

This Subsection is deleted and replaced with the following:

Materials for space frame canopy and steel post support system shall meet the requirements of Subsection 504.02 and the Plans.

504.141 Design

This Subsection is added and includes the following:

Design, detail and load requirements shall conform to the AASHTO Standard Specifications for Structural Supports for Highway Signs, Luminaries, and Traffic Signals, 6th Edition, with 2015 Interims, and shall be subject to approval by the Engineer.

504.161 Fabrication of Space Frame Canopies and Steel Post Support Systems

This Subsection is added and includes the following:

Fabrication shall be in accordance with *ANSI/AASHTO/AWS D1.1 Structural Welding Code* (the D1.1 Code) as modified herein, and the Specifications.

Ends of sections shall be cut true and smooth, free from burrs and ragged breaks. Open ends of tubular sections shall be capped. Drain holes shall be provided where required and as noted on the Plans.

End connections for the space frame canopy chords to the nodal points shall be bolted. No welding shall be used for the field assembly of the space frame canopy. Crimped end connections for tubular members shall not be used in the space frame canopy structure.

Material shall be handled in a manner that prevents nicks, gouges or other damage from chains, wire ropes or other handling devices during all phases of construction.

All surfaces of the completed steel support post system shall be finished with a galvanized coating. The support post system components shall be fabricated in complete units as shown on the Plans, so as to provide for ease of handling in pickling and galvanizing tanks so that galvanizing may be done on the fabricated section. Any repair of zinc coatings damaged by handling and erection shall be kept to a minimum. Damaged galvanized coatings shall be repaired in accordance with ASTM A780.

504.28 Welded Fabrication

The following paragraphs are added:

All welding shall be done in the shop by the inert gas shielded arc method. The procedures, techniques, standards of acceptance, inspection and methods of repair for all welded joints shall be in accordance with AWS D1.1. Any defects detected shall be corrected by removing and replacing the entire weld. Welding electrodes shall be E70XX.

All welds shall be visually inspected and meet the acceptance requirements specified in Sections 6 (Inspection) and 9 (Tubular Structures) of the structural welding code. All welds not meeting these requirements shall be repaired and/or replaced by the Contractor to meet these requirements and check tests, without additional cost to the Authority.

Welds shall be tested using the magnetic particle inspection procedure in accordance as follows:

- 100 percent of the welds securing the support post columns to their base plates.
- No less than 25 percent of all other welds within the completed structure.

Transverse butt welds shall be tested throughout their entire length using radiographic inspection procedures. Longitudinal seam welds shall be tested throughout their entire length using ultrasonic inspection procedures.

504.41 Methods and Equipment

This Subsection is deleted and replaced with the following:

The erection of the space frame canopy shall be in accordance with the space frame canopy Manufacturer's recommendations, as approved by the Engineer, and with the Specifications. A manufacturer's representative of the space frame canopy shall be onsite to supervise the assembly and erection of the space frame canopy.

After the support posts for the canopy have been placed over the anchor bolts onto the leveling nuts, the nuts shall be adjusted until the support posts are truly vertical. The upper nuts shall then be tightened and the space between the concrete base and the underside of the base plate shall be completely filled with non-shrink grout. Following placement of the grout, exposed surfaces of the grout and concrete shall be kept moist for at least 72-hours by means of wet burlap or fabric mats.

Under no circumstances shall the space frame canopy be erected before the expiration of the curing period for the grouted portion of all pedestals.

Verify elevations at top of steel posts prior to erecting space frame canopies. Field-welding of space frame canopy support nodes to steel post cap plates is not permitted. Bolted connections shall be provided between space frame canopy and steel post support system.

Attention is directed to Section 652 of the MTA Supplemental Specifications regarding maintenance and protection of traffic during work adjacent to, or over active roadways. Work adjacent to, or over active roadways will not be permitted unless appropriate traffic control measures are in place and have been approved by the Resident.

504.641 Method of Measurement

The following Subsection is added:

Fabrication and delivery of the accepted space frame canopies will be measured as one lump sum.

Erection of the space frame canopies will be measured as one lump sum.

The steel post support system will be measured as one lump sum, satisfactorily fabricated, delivered and erected.

Any temporary false work or support systems required for the erection process will not be measured for payment separately, but shall be considered incidental to the related Contract items.

504.65 Basis of Payment

This Subsection is deleted and replaced with the following:

The space frame canopy and steel post support system will be paid for at the Contract Lump Sum price for the respective pay items. Payment will be full compensation for all materials, fabrication, inspection, testing, installation, false work, equipment, labor and incidentals necessary to fabricate, deliver, and erect the space frame canopies and post support systems.

Payment will be made under:

<u>Pay Item</u>		<u>Pay Unit</u>
504.80	Space Frame Canopies, Fabricated and Delivered	Lump Sum
504.81	Space Frame Canopies, Erection	Lump Sum
504.90	Space Frame Steel Support Posts and Anchorage Assemblies	Lump Sum

SPECIAL PROVISIONSECTION 504STRUCTURAL STEEL

(Mounting Bracket Assemblies)

504.01 Description

The following paragraphs are added:

This work shall consist of fabricating and erecting Mounting Bracket Assemblies for the support of overhead signs and ORT equipment as shown on the Plans. ORT equipment will be furnished and mounted by others in accordance with the Plans and as directed by the Engineer.

Fabrication and Erection of the Mounting Bracket Assemblies shall be completed in accordance with Subsections 504.01 through 504.11 and with Subsections 504.57 through 504.61.

504.02 Materials

The following paragraphs are added:

The Mounting Bracket Assemblies shall be constructed of hot-dipped galvanized Unistrut Brand materials, manufactured by Unistrut Corporation, or an approved equal.

Nuts, washers, and all miscellaneous hardware, unless otherwise noted, shall be stainless steel conforming to ASTM A276, Type 304. All bolts shall be furnished with nuts and lock washers.

Neoprene spacer pads shall be provided between stainless steel and hot-dipped galvanized surfaces to prevent galvanic corrosion.

Materials not specifically covered in the Plans and Specifications shall be in accordance with the AASHTO Standard Specifications for Structural Supports for Highway Signs, Luminaries, and Traffic Signals, 6th Edition, with 2015 Interims, and shall be subject to approval by the Engineer.

504.03 Drawings

The first sentence of the first paragraph is deleted and replaced with the following:

The Contractor shall submit product data, design computations, fabrication drawings, erection plans, and other necessary working drawings in accordance with Subsection 105.07, Working Drawings.

All Submittals under this Item shall be signed and stamped by a Professional Engineer registered in the State of Maine.

504.16 Fabrication

This Subsection is deleted and replaced with the following:

Ends of sections shall be cut true and smooth, free from burrs and ragged breaks. Material shall be handled in a manner that prevents nicks, gouges or other damage from chains, wire ropes or other handling devices during all phases of fabrication.

All connections between the mounting bracket assemblies and the supporting space frame shall be bolted. No welding will be permitted for field assembly or erection of the mounting bracket assemblies.

All surfaces of the completed mounting bracket assemblies shall be hot dip galvanized. Any repair of zinc coatings damaged by handling and erection shall be kept to a minimum. Damaged galvanized coatings shall be repaired in accordance with ASTM A780.

504.41 Methods and Equipment

This Subsection is deleted and replaced with the following:

The erection of the mounting bracket assemblies shall be in accordance with the Plans, as approved by the Engineer, and with these Specifications.

Attention is directed to Section 652 of the MTA Supplemental Specifications regarding maintenance and protection of traffic during work adjacent to, or over active roadways. Work adjacent to, or over active roadways will not be permitted unless appropriate traffic control measures are in place and have been approved by the Resident.

504.65 Method of Measurement

The following is added:

The specified quantity of Mounting Bracket Assemblies will be measured as one lump sum, satisfactorily fabricated, installed and accepted by the Resident.

504.66 Basis of Payment

This Subsection is deleted and replaced with the following:

Mounting Bracket Assemblies will be paid for at the Contract Lump Sum price for the respective pay items. Payment will be full compensation for all materials, fabrication, installation, equipment, labor and incidentals necessary for furnishing and erecting the Mounting Bracket Assemblies.

Payment will be made under:

<u>Pay Item</u>	<u>Pay Unit</u>
504.91 Mounting Bracket Assemblies	Lump Sum

SPECIAL PROVISION

SECTION 506

SHOP APPLIED PROTECTIVE COATING - STEEL

(Hot-Dip Galvanizing)

506.01 General Specifications

The first paragraph is deleted and replaced with the following:

This work shall consist of applying a hot-dip galvanizing protective coating to metal stair components and support framing in accordance with the Plans and Specifications.

506.05 Inspection

This section is amended by the addition of the following:

The QAI shall be given ample notice in order to inspect the product. "Ample notice" shall be defined at the Pre-Job meeting depending on shop or site conditions.

506.17 Handling and Storage

This section is amended by the addition of the following:

Material shall not be loaded for shipment until the shop coating has been inspected and accepted. The components will be stamped "APPROVED" only after the loading has been completed and approved, and no material shall be shipped without the prior approval of the Resident.

SPECIAL PROVISIONSECTION 506SHOP COATING APPLICATION506.01 Description

This Specification covers the shop cleaning and painting of the steel framing at canopies and stair enclosures (including all connections). Handrails within the tunnel staircases shall also be shop-cleaned and painted per this Specification.

The work shall consist of furnishing all supervisory personnel, competent person(s), labor, tools, equipment, Quality Control activities, materials, and incidentals necessary for satisfactory completion of the work.

506.02 Materials

Materials shall comply with the requirements of the respective Subsections of this Specification.

506.03 Submittals

The Contractor shall submit for review by the Authority a materials list and other such details as described within the Plans and the respective Subsections of this Specification.

506.05 Quality Control

For the purpose of this Specification, the following definitions shall apply:

Quality Assurance Inspector (Q.A.I.): The Authority's authorized representative for shop inspection.

Quality Control Inspector (Q.C.I.): The Contractor's authorized representative for shop surface preparation and application.

Quality Control (Q.C.) is the responsibility of the Contractor. The Q.C.I. shall inspect all aspects of the work and shall supervise required testing. The Q.C.I. shall record measurements and test results in a Job Control Record (JCR). The Q.C.I. shall reject materials and workmanship that do not meet Contract requirements. The results of all testing shall be documented and a copy made available to the Q.A.I. on a daily basis or as requested by the Resident or Q.A.I.

The JCR shall include the following, as applicable:

- Surface Preparation Cleanliness and Anchor Profile – before application of the first or primer coat.
- Environmental Conditions – Ambient temperature, surface temperature, relative humidity, and dew point.

- Dry Film Thickness (DFT) – After the coating has cured and before the application of any subsequent coating.
- Type of testing equipment, model, serial number, and calibration data, if applicable.
- Type of application equipment.
- Coating batch and/or lot number, date of manufacture, and shelf life.
- Manufacturer’s certification of conformance.
- Name(s) of applicator(s).
- Cure data, cure times, temperature, and relative humidity.
- Final inspection by the Q.C.I. and acceptance by the Resident or Q.A.I.

Quality Assurance (Q.A.) is the prerogative of the Authority. The Q.A.I. will ensure that the Q.C. is being performed properly, verify documentation, periodically inspect workmanship and witness testing. Q.A. testing deemed necessary by the Resident in addition to the minimum test requirements shall be scheduled to minimize interference with the production schedule.

Quality Assurance Inspector’s Authority

The Q.A.I. will have the authority to reject material or workmanship that does not meet the Contract requirements. The acceptance of material or workmanship by the Q.A.I. will not preclude subsequent rejection, if materials or workmanship is found unacceptable, by other authorized representatives of the Authority.

Rejections

Rejected material or workmanship, as described above, shall be corrected or replaced by the Contractor at no additional cost to the Authority.

506.08 Contractor Qualification

Shop applied coating systems shall be applied in facilities holding a current AISC Sophisticated Paint Endorsement (SPE) or has been qualified in accordance with SSPC QP3-Standard Procedure for Evaluating Qualifications of Shop Painting Applicators.

All Contractor and Subcontractor SSPC certifications specified above shall be current and in-place prior to bid opening. The Contractor shall ensure that all required SSPC certifications are kept current throughout the duration of the Contract until final acceptance of the work. A copy of valid current certifications shall be transmitted with the Bid Package.

COATING SYSTEM

506.11 Materials

This Subsection is deleted and replaced with the following:

The following coating system shall be used. Alternately, an equivalent system may be proposed and used by the Contractor, subject to approval by the Authority:

Manufacturer:	The Sherwin Williams Company
Primer:	Corothane I Galvapak 1K zinc-rich primer
Intermediate:	Corothane I Ironox B moisture-cure urethane
Finish:	Corothane I HS moisture-cure urethane

All three coats of the paint system shall be contrasting colors as follows:

Primer:	Default by the manufacturer
Intermediate:	As approved by the Resident
Finish:	“Toll Booth Dark Blue”: Color formula to be provided by the Resident

The Contractor shall provide a dried sample of the specified finish color to the Authority for approval prior to the batching of the finish coat. Sample size, shape, and material shall be agreed upon with the Resident prior to submission.

The Contractor shall provide the paint batch description, lot number, date of manufacture, shelf life, and the manufacturer’s published storage requirements to the Resident. The Contractor shall provide the manufacturer's product data sheet for each coating. The product data sheets shall include the manufacturer’s recommended requirements for the equipment, surface cleanliness, mixing, thinning, application, environmental conditions, touch-up/repair procedures, and cure times for the entire range of allowable environmental conditions. All product data sheets and MSDS shall be submitted to the Resident for approval prior to initiating any coating work.

The product data sheets shall also provide the minimum and maximum recoat times for the primer and intermediate coat over the expected range of temperatures, relative humidity, and range of acceptable dry film thicknesses. The manufacturer’s product data sheets at the time of submission shall be those used during the duration of the Project. Newly published product data sheets may be substituted as approved by the Resident.

506.12 Limits of Work

This Subsection is deleted and replaced with the following:

The approved 3-coat system shall be applied to all canopy and sign steel framing and connections. Refer to Sheet Nos. S-39 through S-41 for steel framing sizes and connections details.

The approved 3-coat system shall be applied to all stair enclosure steel framing and connections. Refer to Sheet No. S-32 for steel framing sizes and connection details.

The approved 3-coat system shall be applied to all tunnel staircase handrails. Refer to Sheet Nos. A-05 and A-06 for handrail details.

The faying surfaces of bolted connections shall be painted with one coat of the zinc-rich primer meeting the AASHTO/RCSC requirements for Class B slip-critical connections. This coat shall not exceed the maximum thickness nor fail to meet the minimum cure time specified on the manufacturer’s product data sheet. Both surfaces of bolted connections shall be masked off

within two inches of bolt holes after application and curing of the primer for subsequent coating application. Areas required to be field painted after welding and bolting is complete shall meet the application requirements of Subsection 506.36 Coating Repairs and Touch-up.

506.13 Surface Preparation

This Subsection is deleted and replaced with the following:

Prior to abrasive blast cleaning, all corners and edges of members and plates, whether rolled cut or sheared, exposed in the assembled product shall be rounded to approximately an 1/8-inch radius. A series of tangents to the approximate radius will be considered as a rounded. The Contractor shall prepare a plate approximately 2-inch x 12 inch with the appropriate rounded corner and edge. The Q.C.I. and Q.A.I. shall agree upon the acceptability of the corner preparation and the plate shall become the Job Standard. The plate shall remain the property of the Contractor.

Surfaces to be coated shall be abrasive blast cleaned to meet the requirements of SSPC-SP 10/NACE No. 2 or the coating manufacturer's published recommendations, whichever is the more stringent. SSPC-VIS 1 shall be used to determine acceptable cleanliness. The Q.C.I. and Q.A.I. shall evaluate the first piece using VIS 1 as a comparator. No further blast cleaning shall be done until the Q.C.I. and Q.A.I. agree upon the acceptable Job Standard for cleanliness. If more than one method of abrasive blast cleaning is used (e.g., centrifugal blast and compressed air), the acceptable Job Standard shall be established for each method. At the Contractor's option, a sample piece may be abrasive blast cleaned and sealed with a clear coating to preserve the surface preparation and the sample piece may be used as a comparator to establish the agreed upon Job Standard.

After abrasive blast cleaning, the surface shall be visually inspected for fins, tears, delamination's and other discontinuities. Fins, tears, and other discontinuities shall be removed with a grinder or other suitable power tool and the area shall be blended at a slope of approximately 1:20. The affected area(s) shall be abrasive blast cleaned to develop an acceptable anchor profile.

The anchor profile shall meet the requirements of the coating manufacturer's published recommendations. The blast media shall contain enough grit to provide an angular anchor profile. The anchor profile shall be measured in accordance with ASTM D 4417 Method C. If the anchor profile fails to meet the minimum requirements, the Contractor shall re-blast the substrate until the minimum required anchor profile is achieved. If the anchor profile exceeds the maximum allowed in the manufacturer's published recommendations, the substrate shall be coated only with the approval of the Resident.

The Q.C.I. shall measure the anchor profile of the substrate on each plane of the first piece and each additional piece with a significant change in size or geometry. The Q.A.I. will witness the testing. After it has been established to the satisfaction of the Resident, that the abrasive blast equipment is capable of providing uniform, acceptable surface preparation, a diminished degree of testing may be agreed upon by the Q.C.I. and Q.A.I. The Quality Assurance Inspector may require that the anchor profile be measured and recorded on any surface that is, in the judgment of the Quality Assurance Inspector, unacceptable. Failure to

measure anchor profile as required will result in rejection of the surface preparation on the piece in question.

If there is a significant change in surface cleanliness or anchor profile due to blast media degradation or other reasons, the Contractor shall cease the blast operation until corrective action is taken.

If compressed air is used for abrasive blast cleaning, a blotter test shall be performed in accordance with ASTM D 4285 at the beginning of each shift and at any other time the Q.A.I. directs it. The Q.C.I. and Q.A.I. shall be present to witness the blotter test.

The allowable time between abrasive blast cleaning and primer application shall not exceed the manufacturer's published recommendations or eight-hours, whichever is less. If the substrate develops flash rust (rust bloom) before the primer is applied or before the primer application is completed, the piece shall be re-blasted to bare substrate and re-coated.

506.14 Mixing and Application

This Subsection is deleted and replaced with the following:

All protective coating shall be applied using either conventional or airless spray equipment meeting the manufacturer's published recommendations. Striping and touchup of areas less than 36 in² may be applied by other methods with the approval of the Resident.

Protective coating shall not be applied when the ambient temperature in the immediate vicinity of the piece(s) in question is above 90°F or below 40°F. Thinning and mixing of coatings shall be in conformance with the manufacturer's published instructions. Thinner shall be measured using a graduated cup or other container that clearly indicates the amount of thinner being added. Mixing shall be done using the method, equipment and for the amount of time recommended by the coating manufacturer.

Primer, intermediate, and top coat shall be applied in accordance with the manufacturer's published recommendations. Environmental conditions in the immediate vicinity of the surfaces to be coated shall be within the range of the manufacturer's published requirements both during the coating operation and during the curing period. Primer shall not be force-cured.

Environmental conditions shall be measured by the Q.C.I. in the immediate vicinity of the surfaces to be coated. The Q.A.I. may perform environmental testing in addition to the testing performed by the Q.C.I. If there are significant differences between the test results, the differences shall be resolved or explained to the satisfaction of the Resident prior to coating application. The results of the environmental testing shall be recorded in the JCR.

Corners, fasteners, welds, and inaccessible locations shall be striped in accordance with SSPC-PA 1. The Contractor shall meet the minimum Dry Film Thickness (DFT) requirements on all surfaces. The Contractor may stripe with the intermediate coat if approved by the Resident.

Recoat time shall be in accordance with the manufacturer's published requirements for the environmental conditions at the time of application and cure. If the coating is contaminated with dust, debris, over spray or other deleterious material, the surface shall be cleaned in

accordance with SSPC-SP 1 immediately prior to recoating. Other methods of cleaning may be used if approved by the Resident.

The Q.A.I. shall be given ample notice in order to inspect the product prior to coating, recoating or removal of paint from the area. "Ample notice" shall be defined at the Pre-Job meeting depending on shop or site conditions.

Substrates that are primed or surfaces that are recoated without notification of the Q.A.I. will be rejected and no further coating shall be done on the piece. Coating applied without notification of the Q.A.I. will be investigated by destructive and non-destructive testing as approved by the Resident and by a review of the JCR. The Resident may reject, conditionally accept, or accept the coating based on documentation and test results. Rejected coating shall be removed and reapplied. Conditionally accepted coatings shall be made acceptable as approved by the Resident. The cost of additional testing and repairs shall be borne by the Contractor.

506.15 Dry Film Thickness

This Subsection is deleted and replaced with the following:

DFT shall be measured in accordance with SSPC-PA 2. The results shall be documented in the JCR. The JCR documentation shall include the actual gage readings, spot average and the location(s).

506.16 Coating Repairs and Touch-up

This Subsection is deleted and replaced with the following:

Touch-up shall be done in accordance with the manufacturer's product data sheet and this Specification. Areas to be touched-up shall be prepared to assure proper adhesion of each coat. Each existing coat shall be feathered back to assure that each touch-up coat is continuous with each corresponding existing coat. The top-coat shall be smooth and uniform in appearance.

Damaged or unacceptable coatings shall be repaired using the same coating system. Environmental conditions cure times, and DFTs shall be in accordance with manufacturer's product data sheet for the coating being applied. Repairs to topcoat shall result in a uniform gloss and color match. The Resident shall have final authority concerning acceptable appearance.

506.17 Handling and Storage

This Subsection is deleted and replaced with the following:

The coating shall be adequately cured before handling, but under no circumstances shall the product be handled before the coating has achieved the manufacturer's published minimum cure time. Coated steel members shall be handled in a manner to avoid damage to the coating. Members shall be lifted and moved using non-metallic slings, padded chains and beam clamps, softeners, or other non-injurious methods. Material shall be stored, both at the coating facility and in the field, in a manner that prevents damage to the coating.

Material shall not be loaded for shipment until the shop coating has adequately cured and

been inspected. The components will be stamped "APPROVED" only after the loading has been completed and approved, and no material shall be shipped without the prior approval of the Resident.

Damage to the coating that is discovered after the product is loaded for shipment to the jobsite shall be documented by the Q.C.I. Repairs shall not be made unless the damaged area is repaired in accordance with Subsection 506.26 Coating Repairs and Touch-up. Repairs that cannot be acceptably done on the truck shall be done in the shop or in the field at the Contractor's option.

506.65 Method of Measurement

This Subsection is deleted and replaced with the following:

Shop Coating of New Steel shall be measured for payment by lump sum for the toll plaza work, complete, and accepted. The limits shall be as described within these Specifications.

506.66 Basis of Payment

This Subsection is deleted and replaced with the following:

All work for Shop Coating of New Steel will be paid for at the Contract lump sum price for the toll plaza work. Payment will be full compensation for furnishing all material, labor, equipment, and incidentals necessary for the satisfactory performance of the work.

Payment will be made under:

<u>Pay Item</u>	<u>Pay Unit</u>
506.15 Shop Coating of New Steel	Lump Sum

SPECIAL PROVISIONSECTION 508HIGH PERFORMANCE WATERPROOFING MEMBRANE

(Tunnel and Tunnel Staircases)

508.01 Description

Revise this section to read as follows:

“This work shall consist of furnishing and applying an approved high performance (exterior) waterproofing membrane system to: (1) the roof and sides of the tunnel (both precast and cast-in-place portions) and (2) the roof and sides of the tunnel staircases (both precast and cast-in-place portions located below roadway level). The high performance waterproofing membrane system and its installation shall be in accordance with this specification, other applicable Contract documents and the manufacturer’s published recommendations, complete, in place and accepted. The high performance waterproofing membrane system shall be spray or liquid applied as opposed to a peel and stick (sheet) membrane.

508.02 Materials

Revise this section to read as follows:

“High performance membrane shall include all materials, as recommended by the manufacturer, to produce a waterproof barrier on the specified concrete surface. In addition to the membrane, these materials may include primer, protection board, etc. The following systems have been pre-approved for use on this project:

- 1) Eliminator by Sterling Lloyd Products, Inc., 152 Rockwell Road, Newington, CT 06111, Tel. (860) 666-5008.
- 2) Monolithic Membrane (MM) 6125 by American Hydrotech, Inc., 303 E. Ohio Street, Chicago, IL 60611, Tel. (800) 877-6125
- 3) Procor Composite Waterproofing System by GCP Applied Technologies, Inc., 62 Whittemore Avenue, Cambridge, MA 02140, Tel. (866) 333-3726

The following paragraph is added:

508.07 Installation – Spray Applied High Performance Membrane

The following paragraphs are added:

“Concrete surfaces shall have a uniform, fine-textured finish that is free of protrusions prior to application of the high performance waterproofing membrane system. All honeycombed areas and surface cavities in new and existing concrete

shall be cleaned and filled with approved patching materials. All surfaces to be membraned shall be clean and free of laitance, oil and foreign materials.

Immediately prior to application of the primer, the surface shall be cleaned by brooms and compressed air. The concrete surface shall be inspected and approved by the Resident prior to priming.

Damaged membrane shall be repaired in accordance with manufacturer’s recommendations.”

508.08 Method of Measurement

Revise this section to read as follows:

“High Performance Waterproofing Membrane System for the tunnel (roof and sides), and tunnel staircases (roof and sides located below the roadway) shall be measured by the square yard, complete in place and accepted.”

508.09 Basis of Payment

Revise this section to read as follows:

“High Performance Waterproofing Membrane will be paid for at the Contract unit price, which shall be payment in full for furnishing all materials, labor and equipment, including cleaning of concrete surfaces and providing a moisture meter, and all incidentals necessary to provide a waterproof barrier on the specified concrete surface that is properly adhered to the concrete substrate. Adhesive primer, protection board, etc. provided as part of the waterproofing membrane manufacturer’s system shall be included in the unit price for waterproofing membrane. Cleaning and filling of all honeycombed areas and surface cavities in new and existing concrete surfaces to which membrane is to be applied with approved patching materials shall be included in the unit price for High Performance Waterproofing Membrane. Damage to new or existing concrete surfaces, resulting from the Contractor’s placement or curing operations, or any damage caused by the Contractor’s operations shall be repaired at no cost to the Authority.

Payment will be made under:

<u>Pay Item</u>	<u>Pay Unit</u>
508.14 High Performance Waterproofing Membrane	Square Yard

SPECIAL PROVISIONSECTION 508WATERPROOFING MEMBRANE

(Membrane Waterproofing)

508.01 Description

The following paragraph is added:

The work shall also include furnishing and applying an approved membrane waterproofing system to the canopy column pedestals and utility pit walls as shown on the Plans.

508.02 Materials

The following paragraph is added:

Membrane Waterproofing for the canopy column pedestals and utility pit walls shall consist of an adhesive primer, preformed waterproofing membrane sheet and mastic designed to work as one system. The following systems may be used:

- 1) Jiffy-Seal 140/60 Cold Weather membrane, VOC 100 Primer, 160H Mastic – Manufactured by Protecto Wrap Co.
- 2) 104-AHT membrane, 740 Primer, 104CM Mastic – Manufactured by Royston Laboratories, Inc.
- 3) Bituthene Low Temperature, Bituthene Primer B2, Bituthene Mastic – Manufactured by W.R. Grace

The following paragraphs are added:

508.055 Installation – Membrane Waterproofing

For the canopy column pedestals and utility pit walls, the concrete surfaces shall have a uniform, fine-textured finish that is free of protrusions prior to application of the Membrane Waterproofing system. All honeycombed areas and surface cavities in new and existing concrete shall be cleaned and filled with approved patching materials. All surfaces to be membraned shall be clean and free of laitance, oil and foreign materials.

Immediately prior to application of the primer, the surface shall be cleaned by brooms and compressed air. The concrete surface shall be inspected and approved by the Resident prior to priming.

The adhesive primer shall be thoroughly mixed before use and applied by roller only and allowed to cure in accordance with the manufacturer's recommendations.

Membrane shall be installed in a shingled pattern so that water is permitted to drain without accumulating against seams. The membrane shall be pressed or rolled into place to assure bond with the primed surface and elimination of air bubbles. Lap joints at the beginning and end of rolls shall be staggered with those of adjacent rolls and shall be sealed in accordance with the manufacturer's recommendation.

Torn or damaged membrane shall be repaired in accordance with manufacturer's recommendations.

508.08 Method of Measurement

The following paragraph is added:

Membrane Waterproofing for the canopy column pedestals and utility pit walls will be measured for payment as one lump sum.

508.09 Basis of Payment

The following paragraphs are added:

Membrane Waterproofing will be paid for at the Contract lump sum price, which shall be payment in full for furnishing all materials, labor and equipment, including cleaning of concrete surfaces and providing a moisture meter, and all incidentals necessary to provide a waterproof barrier on the specified concrete surface that is properly adhered to the concrete substrate. Adhesive primer, preformed waterproofing membrane sheets, mastic, and protective board provided as part of the membrane waterproofing manufacturer's system shall be included in the lump sum price for Membrane Waterproofing. Cleaning and filling of all honeycombed areas and surface cavities in new and existing concrete surfaces to which membrane is to be applied with approved patching materials shall be included in the lump sum price for Membrane Waterproofing. Damage to new or existing concrete surfaces, resulting from the Contractor's placement or curing operations, or any damage caused by the Contractor's operations shall be repaired at no cost to the Authority.

Payment will be made under:

<u>Pay Item</u>	<u>Pay Unit</u>
508.15 Membrane Waterproofing	Lump Sum

SPECIAL PROVISIONSECTION 511COFFERDAMS

(Temporary Earth Support Systems)

Section 511, Cofferdams, is deleted in its entirety and replaced with the following:

511.01 Description

This work shall consist of the complete design, construction, maintenance and removal of temporary earth support systems and other related work, including dewatering and inspection, required to allow for the excavation of foundation units, to permit and protect the construction of tunnel, tunnel staircase or other structural units, and to protect adjacent roadways, adjacent public or private rights-of-way, embankments, or other structural units, in accordance with the Contract.

Temporary earth support structures may require pumping or dewatering to complete the Project work. The locations of temporary earth support structures may, or may not, be shown on the Plans whether required for the completion of the Contract or not. Temporary earth support structures do not require seal concrete.

511.02 Materials

The Contractor shall submit Working Drawings for the proposed temporary earth support systems for review and acceptance. The submission shall include plans, details and calculations, for each phase of the construction, designed and sealed by a Professional Engineer licensed in the State of Maine. This Professional Engineer may be directly employed by, or otherwise retained by, the Contractor. Working drawings shall consist of plan views and cross sections to illustrate clearances, limits, and retainment heights as applicable at roadway cuts, cofferdams, abutment footings, and phased construction areas. Construction shall not be started on temporary earth support systems until such submittals are accepted. Any review of or comment on, or any lack of review of or comment on, these Working Drawings by the Department shall not result in any liability upon the Department and it shall not relieve the Contractor of the responsibility for the satisfactory functioning of the earth support system.

Temporary earth retaining structures shall be designed to support all appropriate combinations of earth, hydrostatic, and surcharge loads (from traffic, construction equipment, material stockpiles, and other sources) imposed on the system during all phases of construction. Temporary earth support systems adjacent to traveled ways, shall additionally be designed to resist any vibration or impact forces due to traffic and shall incorporate sufficient protection against impact by errant vehicles. Sufficient redundancy shall be designed into the support system so that failure of one member will not cause the collapse of the entire system. The Contractor's design shall consider the means and methods and construction sequencing proposed by the Contractor.

The Working Drawings shall also show the Contractor's proposed method of excavation, water diversion and dewatering methods (sumps, wells, seal concrete, or well points) to minimize the flow of groundwater into the excavation. Such methods should preserve the undisturbed condition of the subgrade and permit foundation construction in-the-dry.

Design computation shall be in accordance with the AASHTO LRFD Bridge Design Specifications, Latest Edition. The applied loads as well as the load and resistance factors used in the calculations shall be clearly stated on the drawings or submitted calculations.

Following construction of each temporary earth support system the Professional Engineer responsible for the design of the system shall inspect the installation and provide a certification to the Resident stating that construction was completed in conformance with the accepted working drawings. The certification shall be signed and sealed by the Professional Engineer responsible for the design of the system.

511.03 Temporary Earth Support System Construction

Temporary earth support systems shall, in general, be carried well below the elevation of the bottom of footings or approach slabs, and shall be well braced and watertight. In cases where pile foundations contain batter piles, the temporary earth support system shall be installed to accommodate, without obstruction, the proper placement and alignment of the batter piles, either by staggering the depth of the support system or by increasing the annulus between the foundation and the support system. The interior dimensions of temporary earth support systems shall provide sufficient clearance for the construction and inspection of forms and to permit pumping outside of forms. Exterior dimensions of the temporary earth support system shall be limited to the size shown on the Plans or those illustrated in the Project permits, whichever is more stringent.

Temporary earth support systems shall be constructed such that water will not come in contact with concrete as required in Section 502, Structural Concrete.

Temporary earth support systems, including all sheeting and bracing involved, shall be completely removed after the completion of the work unless otherwise noted on the Contract Drawings. Care shall be taken not to disturb or otherwise injure the finished masonry or foundation elements.

No timber or other bracing shall be used in temporary earth support systems in such a way as to remain in the substructure masonry.

511.04 Pumping

Pumping from the interior of any foundation enclosure shall be done in such a manner as to prevent any current of water that would carry away or segregate the concrete.

Pumping to dewater a sealed temporary earth support system shall not commence until the seal concrete has set sufficiently to withstand the hydrostatic pressure. In no case will pumping be permitted until a minimum of five (5) days has elapsed since the completion of the installation of the seal concrete, when the temperature of the water body outside the temporary earth support system is greater than 4°C [40°F], or a minimum of seven (7) days

has elapsed since the completion of the installation of the seal concrete, when the temperature of the water body outside the temporary earth support systems is less than 4°C [40°F].

Sediment laden water will not be allowed to leave the Project area. The Contractor shall be required to install appropriate erosion and sedimentation control devices as approved by the Resident. Erosion and sedimentation control devices may include plain riprap, haybales, silt fence and sedimentation basins.

All water and materials pumped from excavation shall be pumped into a sedimentation basin which is of sufficient volume to detain the pumped water and materials. The water and materials removed from the excavation shall be pumped at a rate that permits infiltration of the water into the earth, preventing any overland flow or direct discharge into a stream or other waterbody.

511.05 Method of Measurement

Temporary Earth Support Systems shall be measured for payment as one lump sum per Contract, regardless of the number of Temporary Earth Support structures required at the Project site or sites, which price shall include full compensation for design, furnishing materials, excavation beyond the pay limits, installation, removal, tools, equipment and labor necessary to construct, maintain and remove the work in accordance with the Plans or as called for in the Contract.

If Temporary Earth Support Systems is not required due to the acceptance of a Value Engineering Proposal in accordance with Subsection 109.6, the cost of the deleted Temporary Earth Support Systems shall be included as part of the Value Engineering Proposal.

511.06 Basis of Payment

The accepted quantity of Temporary Earth Support Systems will be paid for at the Contract lump sum price, per Contract. Such payment shall be full compensation for furnishing and installing all materials required to construct the Temporary Earth Support Systems including, but not limited to steel sheeting and shoring, timber bracing and cribbing, seal concrete, crushed stone. Payment will also be full compensation for excavation, dewatering, erosion control and other incidentals required to construct, maintain and remove the Temporary Earth Support Systems.

When required, the elevation of the bottom of footing of any substructure unit may be lowered, without change in the price to be paid for Temporary Earth Support Systems. However, if the average elevation of more than 25 percent of the area of the excavation is more than three feet below the elevation shown on the Plans, and if requested by the Contractor, then the entire cost of the Temporary Earth Support Systems will be paid in accordance with Subsection 109.7, Equitable Adjustments to Compensation, instead of the Contract lump sum price.

All costs of constructing, maintaining and removing sedimentation basins; water testing; and pumping or transporting water and other materials to the sedimentation basin will not be measured separately for payment, but shall be incidental to the Temporary Earth Support Systems pay item.

All costs of related temporary soil erosion and water pollution controls, including inspection and maintenance, will not be measured separately for payment, but shall be incidental to the Temporary Earth Support Systems item.

Payment will be made under:

<u>Pay Item</u>		<u>Pay Unit</u>
511.091	Temporary Earth Support Systems	Lump Sum

SPECIAL PROVISIONSECTION 515PROTECTIVE COATING FOR CONCRETE SURFACES

(Clear Concrete Protective Coating)

Section 515, Protective Coating for Concrete Surfaces, is deleted in its entirety and replaced with the following:

515.01 Description

The work shall include the surface preparation and application of a clear protective coating on concrete surfaces to protect new cast-in-place and precast concrete.

The coating system shall be applied to all exposed toll islands, bumpers, curbs, fascia, concrete barriers, walls, pedestals, exposed wearing surfaces on concrete slabs, and other exposed concrete surfaces in accordance with the Plans, Specifications and the manufacturer's published recommendations.

515.02 Materials

The penetrating sealer shall be StandOff® SLX100 Water & Oil Repellent, as manufactured by ProSoCo, Inc., or an approved equal. The sealer shall have the following properties:

Active Substance:	modified alkyl alkoxy silane
Active Content:	> 90%
Form:	clear liquid
VOC:	< 3.5 pounds per gallon

The product shall comply with regulations limiting the Volatile Organic Compound (VOC) content of architectural and industrial maintenance coatings.

The Contractor shall submit the ProSoCo's product data sheets, material safety data sheets and recommended instructions for application of the StandOff® SLX100.

Materials shall be delivered to the site in original packages or containers bearing the manufacturer's labels and identification.

515.021 Substitute Materials

The Contractor shall submit a written request for approval of proposed substitute material naming the proposed manufacturer and product. This request shall be accompanied by:

1. Test data from an independent testing laboratory stating that the proposed substitute meets or exceeds the specified requirements as listed and has been tested in accordance with the specified test standards.

2. Documentation that the proposed material has a proven record of performance when used in the intended application as confirmed by actual field tests and successful installations in place on at least five similar projects.
3. Certification that if two or more types of products are intended to be used as part of a system, they will be supplied by the same manufacturer to ensure compatibility of materials, and to maintain single source manufacturer responsibility.

The Resident reserves the right to require additional testing to evaluate any proposed substitute product at no additional cost to the Authority. The Resident's decision as to the acceptability or non-acceptability of the proposed product shall be final.

515.03 Surface Preparation

All caulking, patching, and joint sealant shall be installed prior to application of the sealer. On new surfaces to be treated, all voids shall be dressed by dry rubbing to remove form marks and blemishes to present a neat appearance. Concrete surfaces shall be cleaned free of dust, surface dirt, oil, efflorescence and contaminants to ensure penetration of the sealer. The surface may be slightly damp at the time of treatment.

The Contractor may use, when required, appropriate cleaning materials recommended by the sealer manufacturer in conjunction with high pressure water for cleaning the concrete.

515.04 Application

The Contractor shall apply the clear concrete protective coating in strict accordance with the manufacturer's published recommendations.

The application shall not be conducted when surface and air temperatures are below 40°F or above 90°F. The work shall not be conducted when there is a chance of the surface temperature falling below 40°F in the 24-hours following application; nor should it be applied on hot, windy days.

The treatment shall not be applied during rain to wet surfaces or when there is a chance of rain within 24-hours after application. After treatment, surfaces should be protected from rain for not less than 48-hours. It shall not be applied when winds are sufficient to carry airborne chemicals to unprotected surfaces.

Prior to applying the sealer, the Contractor shall protect all surrounding non-concrete surfaces, landscape and lawn areas, and surfaces not designated for treatment, from contact with the penetrating sealer, and prevent overspray of the penetrating sealer caused by wind drift.

The Contractor shall ensure that all safety equipment, facilities and precautions recommended by the product manufacturer are furnished and/or strictly adhered to.

The sealer material shall be applied in the manner and with the equipment recommended by the product manufacturer. Coverage will vary depending on condition, texture and porosity of the surfaces. Pre-testing is required.

Sealer shall be applied as packaged without dilution or alteration. The sealer shall be applied with low pressure (20 psi) airless spray equipment or with a heavily saturated brush or roller unless otherwise permitted by the Resident. Sufficient material shall be applied to thoroughly saturate the surface making sure to brush out excess material that does not penetrate.

When the sealer is applied to horizontal surfaces, it shall be applied in a single saturating application with sufficient material and applied so the surface remains wet for one to two minutes before penetration into the concrete. Surface residues, pools and puddles shall be broomed-out thoroughly until they completely penetrate into the surface.

When the sealer is applied to vertical and sloped surfaces, it shall be applied in a "wet-on-wet" application for best results on most porous materials. In the case of extremely dense concrete, it may be necessary to restrict the amount of material applied to one saturating application in order to prevent surface darkening. Apply from the bottom up with sufficient material to thoroughly coat the surface and create a slight rundown below the spray pattern. Allow the first application to penetrate the concrete surface, and within a few minutes after the first coat appears dry, reapply in the same saturating manner.

When the sealer is applied to vertical and sloped surfaces, it shall be applied in two applications, 10 minutes apart, with a low pressure (20 psi) airless sprayer.

515.05 Method of Measurement

Clear Protective Coating for Concrete Surfaces will be measured for payment by the square yard, satisfactorily applied and accepted.

515.06 Basis of Payment

Clear Protective Coating for Concrete Surfaces will be paid at the Contract unit price per square yard which price shall be full compensation for all labor, materials, equipment and incidentals required for furnishing and applying the clear concrete protective coating as shown on the Plans, in accordance with these Specifications or as approved by the Resident.

Surface preparation, vegetation removal, and protection of surfaces not designated for treatment will not be measured separately for payment, but shall be incidental to the Clear Concrete Protective Coating item.

Payment will be made under:

<u>Pay Item</u>	<u>Pay Unit</u>
515.202 Clear Protective Coating for Concrete Surfaces	Square Yard

SPECIAL PROVISIONSECTION 515PROTECTIVE COATING FOR CONCRETE SURFACES

(Epoxy Overlay)

515.01 Description

The first paragraph is amended to read:

This special provision describes furnishing and applying two layers of a two-component polymer overlay system in accordance with what is shown on the Plans or as approved by the Resident. The total thickness of the overlay system shall be 1/4 inch.

515.02 Materials

Furnish materials specifically designed for use over concrete. Pre-qualified polymer liquid binders are as follows:

<u>Product Trade Name</u>	<u>Manufacturer or Supplier</u>	<u>Telephone</u>
Mark-163 Flexogrid	PolyCarb, Inc.	(866) 765-9227
E-Bond 526 Lo-Mod*	E-Bond Epoxies, Inc.	(954) 566-6555
Propoxy DOT Type III	Unitex	(816) 231-7700
Sure Level Epoxy (J-57)	Dayton Superior	(888) 977-9600
ICO Flexi-Coat	International Coatings, Inc.	(800) 624-8919
Flexolith	Euclid Chemical Co.	(800) 321-7628

*Preferred product by MTA.

Polymer Resin

The polymer resin base and hardener shall be composed of two-component, 100 percent solids, 100 percent reactive, thermosetting compound with the following properties:

Property	Requirements	Test Method
Gel Time ^A	15 - 45 minutes @ 75° F	ASTM C881
Viscosity ^A	7 - 70 poises	ASTM D2393, Brookfield RVT, Spindle No. 3, 20 rpm
Shore D Hardness ^B	60-75	ASTM D2240
Absorption ^B	1% maximum at 24 hour	ASTM D570
Tensile Elongation ^B	30% - 70% @ 7 days	ASTM D638
Tensile Strength ^B	>2000 psi @ 7 days	ASTM D638
Flexural Strength ^B	>4500 psi @ 7 days	ASTM D790
Chloride Permeability ^B	<100 coulombs @ 28 days	AASHTO T277

^A Uncured, mixed epoxy binder ^B Cured, mixed epoxy binder

Aggregates

Furnish natural or synthetic aggregates that have a proven record of performance in applications of this type. Furnish aggregates that are non-polishing, clean, free of surface moisture, fractured or angular in shape; free from silt, clay, asphalt, or other organic materials; and meet the following properties and gradation requirements:

Aggregate Properties:

<u>Property</u>	<u>Requirement</u>	<u>Test Method</u>
Moisture Content	≤0.2%	ASTM C566
Hardness	≥6.5	Mohs Scale
Fractured Faces	100% with at least 1 fractured face & 80% with at least 2 fractured faces of material retained on No.16	ASTM 5821

Gradation:

<u>Sieve Size</u>	<u>% Passing by Weight</u>
No. 4	100
No. 8	30 – 75
No. 16	0 – 5
No. 30	0– 1

515.21 Required Properties of Overlay System

The required properties of the overlay system are listed in the table below:

<u>Property</u>	<u>Requirement ^A</u>	<u>Test Method</u>
Minimum Compressive Strength at 8 Hrs. (psi)	1,000 psi @ 8 hours 5,000 psi @ 24 hours	ASTM C 579 Method B, Modified ^B
Thermal Compatibility	No Delaminations	ASTM C 884
Minimum Pull-off Strength	250 psi @ 24 hours	ACI 503R, Appendix A

^A Based on samples cured or aged and tested at 75°F

^B Plastic inserts that will provide 2-inch by 2-inch cubes shall be placed in the oversized brass molds.

515.22 Approval of Polymer Overlay System

Submit product data sheets and specifications from the manufacturer, and a certified test report to the Resident for approval.

For materials not pre-qualified, in addition to the above submittals, submit product history/reference projects and a certified test report from an independent testing laboratory showing compliance with the requirements of the specification.

Product data sheets and specifications from the manufacture consists of literature from the manufacturer showing general instructions, application recommendations/methods, product properties, general instructions, or any other applicable information.

515.23 Construction

Conduct a pre-installation conference with the manufacturer's representative prior to construction to establish procedures for maintaining optimum working conditions and coordination of work. Furnish the Resident a copy of the recommended procedures and apply the overlay system according to the manufacturer's instructions. The manufacturer's representative familiar with the overlay system installation procedures shall be present at all times during surface preparation and overlay placement to provide quality assurance that the work is being performed properly.

Store resin materials in their original containers in a dry area. Store and handle materials according to the manufacturer's recommendations. Store all aggregates in a dry environment and protect aggregates from contaminants on the jobsite.

Surface Preparation

Determine an acceptable shotblasting machine operation (size of shot, flow of shot, forward speed, and/or number of passes) that provides a surface a profile meeting CSP 5 according to the International Concrete Repair Institute Technical Guideline No. 03732. If the Resident requires additional verification of the surface preparation, test the tensile bond strength according to ACI 503R, Appendix A of the *ACI Manual of Concrete Practice*. The surface preparation will be considered acceptable if the tensile bond strength is greater than or equal to 250 psi or the failure area at a depth of 1/4 inches or more is greater than 50 percent of the test area. Continue adjustment of the shotblasting machine and necessary testing until the surface is acceptable to the Resident or a passing test result is obtained.

Prepare the entire surface using the final accepted adjustments to the shotblasting machine as determined above. Thoroughly blast cleans with hand-held equipment any areas inaccessible by the shotblasting equipment. Do not perform surface preparation more than 24-hours prior to the application of the overlay system.

Just prior to overlay placement, clean all dust, debris, and concrete fines from the concrete surface including vertical faces of curbs and barrier walls up to a height of one inch above the overlay with compressed air. When using compressed air, the air stream must be free of oil. Any grease, oil, or other foreign matter that rests on or has absorbed into the concrete shall be removed completely.

The Resident may consider alternate surface preparation methods per the overlay system manufacturer's recommendations. The Resident will approve the final surface profile and cleanliness prior to the Contractor placing the epoxy overlay.

Application of the Overlay

Perform the handling and mixing of the epoxy resin and hardening agent in a safe manner to achieve the desired results according to the manufacturer's instructions. Do not apply the overlay system if any of the following exists:

- a. Ambient air temperature is below 50°F;
- b. Concrete surface temperature is below 50°F;
- c. Moisture content in the concrete exceeds 4.5 percent when measured by an electronic moisture meter or shows visible moisture after two-hours when measured in accordance with ASTM D4263;
- d. Rain is forecasted during the minimum curing period;
- e. Materials component temperatures below 50°F;
- f. Concrete age is less than 28 days unless approved by the Resident.

After the concrete surface has been shotblasted or during the overlay curing period, only necessary surface preparation and overlay application equipment will be allowed on the concrete surface. Begin overlay placement as soon as possible after surface preparation operations.

The polymer overlay shall consist of a two-course application of epoxy and aggregate. Each of the two courses shall consist of a layer of epoxy covered with a layer of aggregate in sufficient quantity to completely cover the epoxy. Apply the epoxy and aggregate according to the manufacturer's requirements. Apply the overlay using equipment designed for this purpose. The application machine shall feature positive displacement volumetric metering and be capable of storing and mixing the polymer resins at the proper mix ratio. Disperse the aggregate using a standard chip spreader or equivalent machine that can provide a uniform, consistent coverage of aggregate. First course applications that do not receive enough aggregate before the epoxy gels shall be removed and replaced. A second course applied with insufficient aggregate may be left in place, but will require additional applications before opening to traffic.

After completion of each course, cure the overlay according to the manufacturer's instructions. Follow the minimum cure times as prescribed by the manufacturer. Remove the excess aggregate from the surface treatment by sweeping, blowing, or vacuuming without tearing or damaging the surface; the material may be re-used if approved by the Resident and manufacturer. Apply all courses of the overlay system before opening the area to traffic. Do not allow traffic on the treated area until directed by the Resident.

After the first layer of coating has cured to the point where the aggregate cannot be pulled out, apply the second layer. Prior to applying the second layer, broom and blow off the first layer with compressed air to remove all loose excess aggregate.

Prior to opening to traffic, clean all debris and polymer from the roadway. If required by the Resident, a minimum of three days following opening to traffic, remove loosened aggregates from the concrete and approach pavement.

Application Rates

Apply the epoxy overlay in two separate courses in accordance with the manufacturer's instructions, but not less than the following rate of application.

Course	Minimum Epoxy Rate ^A (GAL/100 SF)	Aggregate ^B (LBS/SY)
1	2.5	10+
2	5.0	14+

^A The minimum total applications rate is 7.5 GAL/100 SF.

^B Application of aggregate shall be of sufficient quantity to completely cover the epoxy.

Minimum Curing Periods

As a minimum, cure the coating as follows:

Course	Average temperature of concrete surface, epoxy and aggregate components in °F					
	60-64	65-69	70-74	75-79	80-84	85+
1	4 hrs.	3 hrs.	2.5 hrs	2 hrs	1.5 hrs.	1 hr.
2 *	6.5 hrs.	5 hrs.	4 hrs.	3 hrs.	3 hrs.	3hrs.

*Cure course 2 for eight hours if the air temperature drops below 60° F during the curing period.

515.05 Method of Measurement

The Authority will measure Epoxy Overlay in area by square yards completed and accepted, in accordance with the Plans.

515.06 Basis of Payment

Payment is full compensation for preparing the surface; for tensile bond testing; for providing the overlay; for cleanup; for sweeping/vacuuming and disposing of excess materials; and for labor, equipment, tools, and incidentals necessary to complete the work.

Payment will be made under:

Pay ItemPay Unit

515.23 Epoxy Overlay

Square Yard

SPECIAL PROVISIONSECTION 515PROTECTIVE COATING FOR CONCRETE SURFACES

(Pigmented Concrete Protective Coating – Tunnel Walls and Ceiling)
(Pigmented Concrete Protective Coating – Tunnel Floor)

This Section is deleted in its entirety and replaced with the following:

515.01 Description

The work shall include the surface preparation and application of a pigmented concrete protective coating system to protect new concrete and masonry structures. The coating system shall be applied to the interior walls, ceiling, and floor of the tunnel in accordance with the Plans, Specifications and the manufacturer's published recommendations.

515.02 MaterialsFor Walls and Ceiling:

The pigmented concrete protective coating system shall consist of Drylok Masonry Waterproofing, as manufactured by UGL, or an approved equal, consisting of the following:

- One primer coat of latex-based Drylok masonry waterproofer. Color: White.
- One finish coat of latex-based Drylok masonry waterproofer. Color: White.

For Floors:

The pigmented concrete protective coating system shall consist of Drylok Concrete Floor Paint, as manufactured by UGL, or an approved equal, consisting of the following:

- One primer coat of latex-based Drylok concrete floor paint. The floor paint shall be brush applied per manufacturer's instructions to provide a non-skid surface. Color: Gray ("Gull").
- One finish coat of latex-based Drylok concrete floor paint. The finish coat shall be brushed or roller applied per manufacturer's instructions to provide a non-skid surface. Color: Gray ("Gull").

The products shall comply with regulations limiting the Volatile Organic Compound (VOC) content of architectural and industrial maintenance coatings.

The Contractor shall submit product data sheets, material safety data sheets and instructions for application of the coating products.

Materials shall be delivered to the site in original packages or containers bearing the manufacturer's labels and identification.

515.021 Substitute Materials

The Contractor shall submit a written request for approval of proposed substitute material naming the proposed manufacturer and product. This request shall be accompanied by:

1. Test data from an independent testing laboratory stating that the proposed substitute meets or exceeds the specified requirements as listed and has been tested in accordance with the specified test standards.
2. Documentation that the proposed material has a proven record of performance when used in the intended application as confirmed by actual field tests and successful installations in place on at least five similar projects.
3. Certification that if two or more types of products are intended to be used as part of a system they will be supplied by the same manufacturer to ensure compatibility of materials, and to maintain single source manufacturer responsibility.

The Resident reserves the right to require additional testing to evaluate any proposed substitute product at no additional cost to the Authority. The Resident's decision as to the acceptability or non-acceptability of the proposed product shall be final.

515.03 Surface Preparation

All caulking, patching, and joint sealant shall be installed prior to application of the concrete protective coating system. The surface shall be prepared in strict accordance with the instructions of the approved manufacturer. Surface shall be fully cured, dry, and free from contamination such as asphalt coatings, oil, grease, loose particles, decaying matter, moss, algae growth, and curing compounds.

The Contractor may use, when required, appropriate cleaning materials recommended by the coating manufacturer for cleaning the concrete or masonry.

A technical representative from the approved coating manufacturer shall visit the site prior to the coating application at no additional cost to the Authority to certify that the concrete surface is suitable for the coating application.

515.04 Application

The materials shall be mixed and applied in strict accordance with the instructions of the approved manufacturer.

The Contractor shall, in the presence of the Resident, apply the materials on a sample area which is representative of a jobsite application. When color and application methods are approved, the sample area shall serve as a standard of acceptance for all further work.

The coatings shall not be applied in direct sunlight when the air or surface temperature is greater than 90°F, or when air or surface temperature is below 35°F. The coatings shall not be applied when air or surface temperature is below 40°F or as approved by the Resident.

The primer coat shall be allowed to dry for a minimum of eight-hours before applying the finish coat. Under poor drying conditions this time shall be extended. The finish coat shall not be applied until the primer coat is dry. The finish coat should be applied by brush or roller.

The finish coat material shall be applied per the manufacturer's recommended application rate and in strict accordance with the manufacturer's written instructions. The finish coat shall provide consistent color without light spots or shadows. The Resident reserves the right to have the Contractor recoat the finish coat if the dried finish coat(s) lack consistent color or show light spots or shadows.

Protect walls, ceiling, and utilities during application of the final coat from splatter.

515.05 Method of Measurement

Pigmented Concrete Protective Coating will be measured for payment by the square yard of final coated surface, satisfactorily applied and accepted. The quantity of primer coat and finish coat will not be measured separately.

515.06 Basis of Payment

Pigmented Concrete Protective Coating will be paid at the Contract unit price per square yard, which price shall be full compensation for all labor, materials, equipment and incidentals required for furnishing and applying the pigmented concrete protective coating as shown on the Plans, in accordance with these Specifications or as approved by the Resident.

Surface preparation and protection of surfaces not designated for treatment will not be paid for separately, but shall be incidental to the Pigmented Concrete Protective Coating item.

Payment will be made under:

<u>Pay Item</u>	<u>Pay Unit</u>
515.2011 Pigmented Concrete Protective Coating - Tunnel Walls & Ceiling	Square Yard
515.2012 Pigmented Concrete Protective Coating – Tunnel Floor	Square Yard

SPECIAL PROVISIONSECTION 526CONCRETE BARRIER

(Temporary Concrete Barrier Type I - Supplied by Authority)

526.01 Description

The following paragraphs are added:

This work shall consist of loading, transporting, setting, resetting, removing, transporting and stacking Temporary Concrete Barrier Type I – Supplied by Authority. The barrier shall have attachments allowing individual sections to be connected into a continuous barrier.

The work also includes supplying connecting pins and furnishing and mounting retro-reflective delineators, per Subsection 526.02 and 526.03.

Concrete barriers supplied by Authority shall be available at the following location(s):

<u>Maintenance Area</u>	<u>Linear Feet of Barrier</u>
Kennebunk Maintenance Area	4,000

Upon substantial completion of work, the Contractor shall remove and transport the barrier back to its maintenance area of origin. All barrier shall be returned, sorted and stacked according to type in locations directed by the project Resident or maintenance area foreman.

Temporary traffic barrier required for maintenance of traffic, above and beyond the 4,000 linear feet provided by the Authority in this Section, shall be provided in accordance with Section 652 – Temporary Barrier.

526.021 Acceptance

The Resident shall have the authority to accept or reject all Temporary Concrete Barrier Type I – Supplied by Authority used on the Project that does not meet the requirements of this specification

526.03 Construction Requirements

The following paragraphs are added:

The Contractor shall notify the Resident prior to the scheduled pick-up and delivery of concrete barrier. No barrier shall be removed from or stacked at the Turnpike Maintenance Area without approval of the Resident.

The Contractor shall move and place barrier-utilizing methods that will not damage the barrier. Barrier that is damaged by the Contractor by failing to use proper methods shall be replaced by the Contractor at no additional cost to the Maine Turnpike Authority.

Concrete barrier supplied by the Authority consists of several different styles. Not all barriers may be compatible. The Contractor shall utilize caution when setting barrier to use identical barrier types as adjacent barrier. Non-compatible barrier that cannot be attached together shall be overlapped by a minimum of 10 feet with the blunt end on the non-traffic side of the barrier. This work will not be measured separately for payment, but shall be incidental to the concrete barrier.

Concrete barrier placed at roadway low points shall be shimmed on 1" by 2" by 2' long wood planks to allow drainage to pass under the barrier. In addition, the Resident may direct the Contractor to shim the concrete barrier at other locations to provide for proper roadway drainage. All labor, material, and equipment necessary to shim the barrier will not be measured separately for payment, but shall be incidental to the Concrete Barrier.

The removal of concrete barrier from adjacent to the travel lane may be conducted without a lane closure if it is accomplished in accordance with the following requirements:

1. Barrier is removed from the trailing end and the workmen and equipment involved in the operation are always behind the barrier. No workmen or equipment shall enter the travel lane.
2. Barrier shall be dragged away from the travel lane to at least a 30-degree angle by the use of a cable.
3. Barrier shall be lifted no more than six inches while within 10 feet of the travel lane.

Retro-Reflective Delineators shall be mounted as follows:

4. One on top of each barrier.
5. One on the traffic side of every barrier used in a taper.
6. One on the traffic side of every other barrier at regularly spaced intervals and locations.
7. Delineators shall be installed on both sides of the barrier if barrier is used to separate opposing traffic.
8. Delineators shall be physically adhered so as to withstand the force of throw from a snow plow.
9. If more than 25% of delineators in any 50 foot section of barrier fall off for any reason, the Contractor will be responsible for reinstalling all the delineators in that run at that their own cost.
10. Contractor is required to submit the installation method for review and approval to the Resident.

526.04 Method of Measurement

The following paragraphs are added:

Temporary Concrete Barrier Type I – Supplied by Authority shall be measured for payment by the lump sum.

The loading, transporting, setting, resetting, removing, transporting, sorting and stacking of the barrier, the furnishing, installation and maintenance of the barrier delineators, and furnishing and installing connector pins will not be measured separately for payment, but shall be incidental to the cost of the Barrier. Temporary storage of Concrete Barrier between construction phases, if required, will not be measured separately for payment, but shall be incidental to the cost of the Barrier. All equipment required to load, unload, transport and stack Concrete Barrier shall be supplied by the Contractor.

Any Barrier lost or damaged by the Contractor shall be replaced by the Contractor at no additional cost to the Authority.

526.05 Basis of Payment

The fifth paragraph is deleted and not replaced.

The following paragraphs are added:

Temporary Concrete Barrier Type I – Supplied by Authority will be paid for at the Contract lump sum price, complete in place. Such payment shall be full compensation for loading, transporting, setting, resetting, temporary storage, removing, transporting and stacking at the area designated, furnishing all materials, and all other incidentals necessary to complete the work. Temporary Concrete Barrier Type I – Supplied by Authority and all connecting pins shall remain the property of the Authority, and shall be returned to the Turnpike Maintenance Area as designated in Subsection 526.01.

Payment of Concrete Barrier shall be based on a percentage of the work accomplished during that pay period.

Payment will be made under:

<u>Pay Item</u>	<u>Pay Unit</u>
526.306 Temporary Concrete Barrier Type I – Supplied by the Authority	Lump Sum

SPECIAL PROVISION

SECTION 526

CONCRETE BARRIER

(Temporary Barrier Markers)

526.01 Description

The following paragraphs are added:

This work shall consist of furnishing, installing and maintaining temporary barrier markers on all temporary barrier supplied by the Contractor and the Authority.

526.02 Materials

The following paragraphs are added:

Temporary barrier markers shall be "Big Dog" barrier markers manufactured by Custom Products Corporation, or approved equal. Markers shall be bi-directional with a minimum effective reflective area of 96 square inches (48 square inches each side) as approved by the Resident. The reflectors shall meet MUTCD reflectivity requirements and shall be orange in color.

526.03 Construction Requirements

The following paragraphs are added:

Temporary barrier markers shall be mounted as follows:

1. One on top of each barrier, including all barriers supplied by the Authority and all barriers furnished by the Contractor.
2. Delineators shall be physically adhered so as to withstand the force of throw from a snow plow.
3. If more than 25% of delineators in any 50 foot section of barrier fall off for any reason, the Contractor will be responsible for reinstalling all the delineators in that run at that their own cost.
4. Contractor is required to submit the installation method for review and approval to the Resident.

526.04 Method of Measurement

The following paragraphs are added:

Temporary barrier markers shall not be measured for payment separately but shall be incidental to the temporary barrier item.

526.05 Basis of Payment

The following paragraphs are added:

Temporary barrier markers shall not be paid for separately but shall be incidental to the temporary barrier item.

SPECIAL PROVISIONSECTION 526CONCRETE BARRIER

(Median Barrier Type I, IA, IB, II, IIIA, IIIB,)
(Median Barrier Transition Type I, IA, IB, II, LP-A, LP-B)

526.1 Description

This Section is deleted and replaced with the following:

This work shall consist of the furnishing, constructing, erecting, and setting permanent concrete barrier and associated elements in accordance with these Specifications and the lines and grades shown on the Plans or established by the Resident. The length of each precast barrier segment shall be in accordance with the parameters shown on the Plans. The Contractor shall minimize the number of joints in the final barrier assembly to the extent possible.

Median Barrier Type I – Precast Double faced single slope barrier 2'- 0" wide at the base, 48" high and 45" reveal as shown on the Plans.

Median Barrier Type IA - Precast Double faced single slope barrier 2'- 3 3/4" wide at the base, 60" high and 45" reveal as shown on the Plans.

Median Barrier Type IB - Precast Double faced single slope barrier 2'- 9 1/2" wide at the base, 78" high and 45" min. reveal as shown on the Plans.

Median Barrier Type II – Precast Double faced single slope barrier 4'- 0" wide at the base, 60" high and 57" reveal as shown on the Plans.

Median Barrier Type II – Cast in Place Double faced single slope barrier 4'- 0" wide at the base, 60" high and 57" reveal as shown on the Plans.

Median Barrier Type IIIA – Precast Double faced single slope barrier 1'- 6 5/8" wide at the base, 60" high and 57" reveal as shown on the Plans.

Median Barrier Type IIIB - Precast Single faced single slope barrier 1'- 9 1/2" wide at the base, 78" high and 45" reveal as shown on the Plans.

Median Barrier Transition Type I - Precast Section of barrier to transition from double faced single slope barrier to vertical section for guardrail attachment as shown on the Plans.

Median Barrier Transition Type II - Precast Section of barrier to transition from Median Barrier Type I to Median Barrier Type II as shown on the Plans.

Median Barrier Transition Type IA - Precast Section of barrier to transition from Median Barrier Type I to Median Barrier Type IA as shown on the Plans.

Median Barrier Transition Type IB - Precast Section of barrier to transition from Median Barrier Type IA to Median Barrier Type IB as shown on the Plans.

Median Barrier Transition Type LP-A Section of barrier to transition from Median Barrier Type IA to Median Barrier With Mounted Light Pole Type LP-A as shown on the Plans.

Median Barrier Transition Type LP-B Section of barrier to transition from Median Barrier Type IB to Median Barrier With Mounted Light Pole Type LP-B as shown on the Plans.

Median Barrier With Mounted Light Pole Type LP-A - Cast in Place Section of barrier to transition from Median Barrier Type IA to Median Barrier Type LP-A as shown on the Plans.

Median Barrier With Mounted Light Pole Type LP-B - Cast in Place Section of barrier to transition from Median Barrier Type II to Median Barrier Type LP-B as shown on the Plans.

526.2 Materials

The second paragraph is deleted in its entirety and replaced with the following:

All concrete Median Barrier and Median Barrier Transitions, except Median Barrier Type II, Median Barrier with Mounted Light Pole Type LP-A, Median Barrier with Mounted Light Pole Type LP-B, shall be supplied as precast units produced by an approved commercial precasting plant. Precast concrete shall be Class P, in accordance with Supplemental Specifications, Section 502.05 - Composition and Proportioning, with a minimum compressive strength of 4,500 psi. Cast-in-Place concrete shall be Class AAA-Deck (without synthetic reinforcement) in accordance with Supplemental Specifications, Section 502.05 - Composition and Proportioning, with a minimum compressive strength of 4,500 psi.

Materials for barrier connection assemblies shall be fabricated in accordance with MaineDOT Standard Specification 504. All barrier connection assemblies shall be hot dip galvanized after fabrication in accordance with ASTM A123 and A153.

The second paragraph is amended by the addition of the following:

All reinforcing steel for concrete barrier shall be epoxy coated. Reinforcing steel shall be fabricated and placed in accordance with the Standard Specifications, Section 503.

526.3 Construction Requirements

The first and second paragraphs are deleted and replaced with the following:

All permanent concrete barrier and transition barrier shall be constructed in accordance with the provisions of Special Provision 502 – Composition and Proportioning, through Section 502.15 – Curing Concrete, inclusive, with the following additions:

- a. The following is added to Section 502.10 A. – Construction of Forms, after Construction of Forms: “Permanent concrete barrier shall not be formed using slip forming methods. Temporary concrete barrier may be formed by precasting and/or prestressing methods.”

The following paragraphs are added after the fourth paragraph:

- d. Sections of barrier shall be uniform in color and in good condition, free from cracked or spalled surfaces.
- e. Defects shall be divided into two categories, minor defects and major defects. Minor defects in the barrier may be repaired in the field. Major defects shall be cause for rejection of the section or, at the Authority's sole discretion, the section shall be repaired in a manner directed by the Resident.

Minor defects are defined as holes, honeycombing or spalls which are 6 inch or less, in diameter, and which do not expose the outermost surface of the steel reinforcement. Surface voids 3/8 inch, or less, in diameter and 3/8 inch, or less, in depth are not considered defects and do not require repair.

Major defects are defined as any defect which does not meet the definition of a minor defect or minor defects which, in aggregate, comprise more than 2% of the surface area of the barrier section.

The repair of hardened concrete shall be as follows:

- Minor Defect Repair: Repair shall be made with a fast set non-shrink patching material included on MaineDOT's list of prequalified materials. Methods of repair shall be acceptable to the Resident. The color of the repaired portion shall match as nearly as practicable, the color of the surrounding concrete. Repaired portions shall match shape and tolerance requirements.
- Major Defect Repair: Major defect repair shall be pre-approved by the Engineer.

The following paragraphs are added at the end of this section:

The layout and placement of the concrete barriers shall be to the alignment and elevations shown on the Plans or as directed. Before any barrier or transitions may be placed, the subbase shall be compacted to 95 percent density and fine graded to a tolerance of +/- 1/2 inch of the true grade at any location under the barrier.

All Cast-in-Place barrier adjacent to precast barriers shall include hardware for the barrier connection as detailed in the Plans.

526.4 Method of Measurement

The following paragraphs are added:

Median Barrier Type I, IA, IB II – Precast, II – Cast in Place, and IIIA, and IIIB will be measured for payment by the linear foot from end to end of each run of barrier measured along the centerline of the barrier complete in place. No deduction in pay length will be made for joints between abutting barrier sections.

Median Barrier Transition Type I, IA, IB, II, LP-A, and LP-B will be measured by each barrier as shown on the Plans.

Median Barrier with Mounted Light Pole Type LP-A and LP-B will be measured by each barrier as shown on the Plans.

526.5 Basis of Payment

The following paragraphs are added:

The accepted quantities of Median Barrier Type I, IA, IB, II, IIIA and IIIB will be paid for at the Contract unit price per linear foot, as specified, complete in place. Such payment shall be full compensation for furnishing all material, assembling and all incidentals necessary to complete the work.

The accepted quantities of Median Barrier Transition Type I, IA, IB, II, IIIA and IIIB shall be paid for at the Contract unit price per each, as specified, complete in place.

Payment will be made under:

<u>Pay Item</u>	<u>Pay Unit</u>
526.351 Median Barrier Type I - Precast	Linear Foot
526.3511 Median Barrier Type IA - Precast	Linear Foot
526.3512 Median Barrier Type IB - Precast	Linear Foot
526.352 Median Barrier Type II - Precast	Linear Foot
526.3522 Median Barrier Type II – Cast in Place	Linear Foot
526.3531 Median Barrier Type IIIA - Precast	Linear Foot
526.3532 Median Barrier Type IIIB - Precast	Linear Foot
526.361 Median Barrier Transition Type I - Precast	Each
526.3611 Median Barrier Transition Type IA - Precast	Each
526.3612 Median Barrier Transition Type IB - Precast	Each
526.3613 Median Barrier Transition Type LP-A	Each
526.3614 Median Barrier Transition Type LP-B	Each
526.362 Median Barrier Transition Type II - Precast	Each
526.371 Median Barrier with Mounted Light Pole Type LP-A – Cast in Place	Each
526.372 Median Barrier with Mounted Light Pole Type LP-B – Cast in Place	Each

SPECIAL PROVISION

SECTION 527

ENERGY ABSORBING UNIT

(Work Zone Crash Cushion)

527.01 Description

The first paragraph is deleted in its entirety and replaced with the following:

The Contractor shall furnish and install work zone crash cushions where shown on the Plans, as specified herein, in Special Provision 652, or as approved by the Resident. Work zone crash cushions are required at each exposed end of temporary barrier or guardrail.

The exposed end of the concrete barrier within 30 feet of the mainline travel lane shall be protected at all times. Barrier shall not be reset until after the work zone crash cushion(s) has been set to protect the exposed end of the barrier.

527.02 Materials

The following paragraph is added:

Only work zone crash cushions meeting the NCHRP Report 350 TL-3 crash test requirements may be used on the turnpike and local roadways with posted speeds of 45 MPH or greater. Work zone crash cushions meeting the NCHRP Report 350 TL-2 crash test requirements may be used on local roadways with posted speeds of 40 MPH or less. The Contractor shall provide the Resident with documentation of the proposed work zone crash cushion's NCHRP Report 350 Crash Test Results prior to installation at the jobsite.

527.03 Construction Requirements

The following is added to the end of the first paragraph:

The design speeds for work zone crash cushions shall be 45 mph for local road and 70 mph for turnpike roadways unless otherwise noted on the Plans.

527.04 Method of Measurement

Work Zone Crash Cushions will be measured separately for payment by the unit.

527.05 Basis of Payment

Payment will be made under:

<u>Pay Item</u>	<u>Pay Unit</u>
527.341 Work Zone Crash Cushions – TL-3	Unit

SPECIAL PROVISIONSECTION 527ENERGY ABSORBING UNIT(Center Barrier Crash Attenuator)527.01 Description

This task shall include furnishing, installing and securing the energy absorbing units as described in the Plan drawings and detailed by the vendor. Drawings and general provisions of this Contract, including General Provisions and Special Conditions, apply to work of this Section.

527.02 Materials

Energy absorbing units shall be Smart Cushion[®] manufactured by Work Area Protection Corp., or an approved equal. Units must be fully re-directive, non-gating and suitable for installation on a concrete or asphalt surface. The energy absorbing units shall be approved by AASHTO Manual for Assessing Safety Hardware (MASH) Test Level 3 with a 70 mph impact speed and must be approved by the Resident.

527.03 Execution

Installation and securing of the energy absorbing units shall be done according to the manufacturer's recommendations so that the unit meets MASH Test Level 3 criteria with a 70 mph impact speed. Installation must be approved by the Resident.

Basis of Payment

The energy absorbing units will be paid for at the Contract unit price per each which shall include all associated hardware and equipment required for a complete operational system which meets MASH Test Level 3 with a 70 mph impact head.

Payment will be made under:

<u>Pay Item</u>	<u>Pay Unit</u>
527.306 Center Barrier Crash Attenuator	Each

SPECIAL PROVISIONSECTION 534PRECAST STRUCTURAL CONCRETE

(Precast Concrete Tunnel and Tunnel Staircase Structures)

534.02 Materials

Revise the paragraph that begins “Bedding and backfill material shall conform...” to read as follows:

“Bedding and backfill material shall conform to the requirements of Standard Specification 304 for Aggregate Base Course Type A.”

The following information is added:

Joint Sealants:

Self-leveling joint sealant (to be used at top exterior surface of joint) shall be Sikaflex 1C-SL or an approved equal. Material shall be a premium-grade, high-performance, self-leveling one-part polyurethane sealant. Material shall meet Federal Specification TT-S-00230C, Type I, Class A; ASTM C920, Type S, Grade P, Class 25; and shall exhibit the following minimum data properties at 21 days:

Shore A Hardness: 40 +/-5 (ASTM D2240)
 Tensile Strength: 150psi (ASTM D412)
 Elongation @ Break: 450% (ASTM D412)
 Modulus of Elasticity: 110psi (ASTM D412, @ 100%)

Non-sag joint sealant (to be used on vertical surfaces) shall be Sikaflex 1A or an approved equal. Material shall be a premium-grade, high-performance, moisture cured polyurethane-based elastomeric sealant. Material shall meet Federal Specification TT-S-00230C, Type II, Class A, and ASTM C920, Type S, Grade NS, Class 35.

Shore A Hardness: 40 +/-5 (ASTM D2240)
 Tensile Strength: 175psi (ASTM D412)
 Elongation @ Break: 550% (ASTM D412)
 Modulus of Elasticity: 85psi (ASTM D412, @ 100%)

Non-Shrink Grout Materials:

Non-shrink grout material shall be chosen from the MaineDOT qualified product list for grout materials. The design compressive strength shall be no less than 5,000 psi.

Gasket Materials:

Gasket material for sealing the joints between adjacent precast segments shall be BW™ gasket for box structures as manufactured by Vertex, Inc., or an approved equal. The gasket shall be a continuous one-piece rubber gasket, which is installed in the manufacturing facility onto the outer peripheral surface of each spigot in such that the gasket encircles the spigot. The gasket shall be comprised of a synthetic rubber compound which meets the requirements of ASTM C1619 Class C and ASTM C443. Material shall be shaped with rounded-corners and shall exhibit the following minimum data properties:

Shore A Hardness: 50 +/-10 (ASTM D2240)
 Tensile Strength: 1200 psi (ASTM D412)
 Elongation @ Break: 350% (ASTM D412)
 Watertightness: 13 psi (ASTM C1677)
 Installation: Per manufacturer's instructions

Connection Rods:

Connection rods and corresponding nuts and bearing plates shall be galvanized and shall be made of a high strength steel material such as a DSI Dywidag system or an approved equal. Connections rods, nuts and bearing plates shall be in conformance with the following minimum data properties:

Bar Diameter: 1 inch (26 mm) (min.)
 Ultimate Stress: $f_u = 150$ ksi (ASTM A722)
 Ultimate Tensile Load: $F_u = 127.5$ kips
 Bearing Plates: $F_y = 36$ ksi (ASTM A36)

534.11 Reinforcing Steel

The following paragraph is added:

“The mild steel reinforcing shall be Grade 60 ksi in accordance with ASTM A615 and shall be epoxy coated in accordance with ASTM A775.”

534.12 Voids and Inserts

The following paragraph is added:

“The Contractor shall take notice that there are voids/penetrations identified in several tunnel segments for the installation of utilities. This information shall be shown on the shop drawings. Steel reinforcement layout shall be predetermined to avoid conflicts with penetrations. Penetrations shall be formed with sleeves prior to casting of the segments. Field drilling will not be permitted without written consent from the Engineer of Record.”

534.14 Process Control Test Cylinders

Revise this subsection to read:

“534.14 Acceptance and Quality Control Testing of Concrete Refer to Special Provision Section 712.061.”

534.16 Tolerances

Revise this section to read:

Dimensional tolerances shall conform to the following:

- A. The internal dimensions shall not vary by more than 1 percent from the design dimensions or one-quarter inch, whichever is less, with the exception of the cross diagonal dimension, which shall not vary by more than one-half inch from the design dimension.
- B. The haunch dimensions shall not vary by more than one-quarter inch from the design dimension.
- C. The dimensions of the legs shall not vary by more than one-quarter inch from the dimension shown on the reviewed Working Drawings.
- D. The slab and wall thickness shall not be less than the design thickness by more than one-quarter inch. A thickness greater than the design thickness shall not be cause for rejection.
- E. Variations in laying lengths of two opposite surfaces shall not be more than 1/8 inch/foot of the internal span with a maximum of one-half inch in any unit.
- F. The under-run in length of any unit shall not be more than one-half inch.
- G. The position of reinforcement shall not vary from the approved shop drawings by more than 1/2 inch in any direction. Place reinforcement so the indicated cover clearance does not deviate more than +/- 1/4 inch). Provide 1-1/2 inch minimum cover at the mating surface, as measured to the end of the joint.
- H. Joint gap between segments shall be no more than 1/2 inch (to minimize joint sealant materials).
- I. Variations in slab or wall thicknesses between adjacent segments shall not exceed 1/4 inch. Lipping on internal surfaces between adjacent segments shall not exceed 1/8 inch.

534.20 Installation of Precast Units

Revise the first sentence of the second paragraph to read as follows:

“Precast tunnel and staircase sections shall be sealed with a flexible joint sealant in accordance with this Section (see Paragraph 534.02 above).”

Revise the paragraph that begins “Completely fill the exterior face of joints....” to read as follows:

“Completely fill the exterior face of joints between precast units with a material from the MaineDOT QPL and cover with a minimum 12 inch wide joint wrap. Additionally, for precast tunnel and staircase elements, cover the entire top surface and entire sides with exterior high performance waterproofing membrane in accordance with Special Provision Section 508. The surfaces shall be free of dirt and deleterious materials before applying the filler material and joint wrap. Install the external wrap in one continuous piece over each unit joint, taking care to keep the joint wrap in place during backfilling.”

Revise the fourth sentence of the sixth paragraph to read as follows:

“Compact the bedding and backfill in accordance with Section 203.12, Construction of Earth Embankment with Moisture and Density Control, except that the minimum required compaction shall be 98 percent of maximum density, as determined by AASHTO T-180, Method C or D.”

The following paragraphs are added:

“Precast tunnel segments shall be erected as shown on the Plans. Subbase materials shall be installed to the grades and compactness shown on the plans prior to setting the tunnel segments. Manufacturer-installed gaskets shall be checked prior to setting each segment to ensure the gasket is securely affixed at the concrete joint. Defective gaskets shall be immediately replaced, and gaskets not securely fastened to the concrete shall be repaired with factory-supplied adhesive for field installation.

The precast tunnel segment shall be set to the elevation and location shown on the Plans. Once in position, the next tunnel segment shall be aligned and adjoined to the previous segment. When adjoining segments care shall be taken to prevent subbase materials from fouling the lap splice joint and the adhesive material along the bottom lap splice joint. Prevention of subbase migration into the joint may be accomplished using a thin sheet of pressure-treated plywood. In lieu of plywood, a low-friction sheet material may be used. Sheet materials may be left in place if less than 1/4 inch thick.

Prior to releasing subsequent segments from the crane support, the segment shall be tightened to the adjoining segment by installing the connection rods at the interior pocket locations to create a watertight seal at the joint. Bearing plates and nuts shall be readily available on-hand to commence the tightening of the rods. To overcome the bottom friction between the tunnel segment and the subbase materials, the crane may be used to lift the tunnel segment and to slightly lift the previously installed tunnel segment to enable a tight fit at the joint. Once the joint is tight and the rods are hand-tightened, the position of the tunnel segments shall be checked for alignment and condition. Tolerances shall be checked and maintained, including the gap between the segments. Upon successful inspection by the resident, the crane may release the segments and tunnel construction may continue.

After setting all of the tunnel segments within the specific construction phase, and after tightening of the connection rods, the joint sealant material shall be applied to the segment gaps per the joint sealant manufacturer's instructions. Backer rod material may be used around the perimeter of the joint so that the depth of the joint sealant material is no greater than 1 inch. Special care shall be taken to ensure full application along the gaps of the segment with the exception of the exterior gap of the base slab, which will not receive any joint sealant material. Non-sag joint sealant material shall be used on the vertical surfaces and ceiling, while self-leveling joint sealant material shall be used on the top exterior surface of the joint as well as the floor.

Joint wrap shall be applied at joints prior to application of the exterior waterproofing membrane system.

Exterior waterproofing membranes shall be applied to the exterior tunnel faces (including underground sections of the stairwells) once all tunnel sections are fully installed for the designated construction phase. Full installation shall include snug-tight fitting of the tunnel segments and hand-tightening of the connection rods. Exterior perimeter drainage and backfill shall be installed upon completion of the waterproofing installation.

Temporary earth support systems placed at the opening of the tunnel segments in support of phased construction shall be installed in accordance with Section 511 of these Specifications. Care shall be taken to prevent any damage, settlement, or shifting of the tunnel segments during installation of the temporary earth support system.

Bolt pockets (connection rod locations) shall be filled with non-shrink grout.

The walls and ceiling of the tunnel shall be coated with a pigmented coating as described in Special Provision 515. Wall and ceiling coating shall be applied prior to installation of utilities.

The floor of the tunnel shall be coated with a non-skid coating material as described in Special Provision 515. The floor coating shall only be applied once all tunnel segments and architectural enclosures are installed and the tunnel is weather tight.”

534.21 Method of Measurement

Revise this section to read:

“Precast concrete portions of the tunnel and tunnel staircase structures will be measured as one lump sum, complete, in place and accepted.”

534.22 Basis of Payment

The following paragraph is added:

“Mechanical bar splicers (couplers) embedded in precast elements for continuation of reinforcement with adjacent cast-in-place reinforced concrete (e.g., at the interface of the precast staircase elements and the cast-in-place stair enclosure barriers) will not be measured and paid for separately, but will be incidental to the lump sum pay item.”

Revise the last paragraph as follows:

Payment will be made under:

<u>Pay Item</u>		<u>Pay Unit</u>
534.71	Precast Concrete Tunnel and Tunnel Staircase Structures	Lump Sum

SPECIAL PROVISIONSECTION 602PIPE LINING

(Flowable Concrete Fill)

602.01 Description

This work shall consist of providing and placing flowable concrete fill at the locations designated on the Plans.

602.02 Materials

Materials shall conform to the requirements specified in the following Subsections of Division 700 — Materials:

- | | |
|-----------------------------|-----------------------|
| ▪ Portland Cement | 701.01 |
| ▪ Water | 701.02 |
| ▪ Air Entraining Admixtures | 701.03 |
| ▪ Water Reducing Admixtures | 701.04 |
| ▪ Fly Ash | 701.10 |
| ▪ Fine Aggregate | 703.01 |
| ▪ Accelerating Admixtures | AASHTO M-194 Type “C” |

602.03 Composition and Proportioning

Flowable concrete fill shall be composed of a homogeneous mixture of Portland Cement and/or pozzolans, fine aggregate, water, and chemical admixtures proportioned according to these Specifications.

The flowable concrete fill shall be proportioned to produce a 28 day compressive strength of 110-500 psi.

The water cement ratio for flowable concrete fill shall not be high enough to cause segregation of the mix.

Air content of five to 15 percent is the target. Higher air contents may be acceptable but will increase set time. All flowable concrete fill shall be air entrained by the addition of an air entraining admixture or other chemical admixtures.

At least 30 days prior to the first placement, a flowable concrete fill mix design shall be submitted by the Contractor to the Resident for approval. No flowable concrete fill shall be placed on the Project until the mix design is approved by the Resident. At a minimum, the mix design submitted by the Contractor shall include the following:

- A. Target water cement ratio
- B. Target strength

C. Target air content

602.04 Quality Control

Process control measurements of air content, mix temperature, and slump shall be performed on the portion or portions of flowable concrete fill batches delivered to the site. At least one (1) set of measurements for air content, temperature, and slump of flowable concrete fill mix shall be performed per placement or per day, whichever is less frequent. Test cylinders will not be required.

Air content shall be measured following the requirements of AASHTO T152 utilizing Type B equipment.

Slump shall be measured by Modified Slump Test as described below.

Apparatus:

Scoop, measuring tape, flat edge, 3 in. x 6 in. cylinder mold open at both ends, and a flat non-absorbent surface.

Procedure:

1. Set cylinder upright on flat non-absorbent surface.
2. Scoop representative sample of flowable concrete fill.
3. Fill the cylinder, with the sample in one lift without tamping. Strike-off the top with the flat edge to form a level surface.
4. Clear any residue from around the bottom of the cylinder.
5. During a count of three seconds, lift the cylinder straight up allowing the sample to spread on the flat surface.
6. Measure the spread diameter to the nearest 1/2 inch. A spread of nine to 14 inches is considered flowable.

602.05 Batching

Measuring and batching of materials shall be performed at an approved batching plant, either commercial or otherwise.

602.06 Mixing and Delivery

The Contractor shall provide a Certificate of Compliance as described in Standard Specification Section 502, Structural Concrete, Subsection 502.0501, Quality Control METHOD C, for each truckload of flowable concrete fill.

602.07 Cold Weather Placement

The following amended requirements of Standard Specification Section 502, Structural Concrete, Subsection 502.08, Cold Weather Concrete, will apply.

The Cold Weather Temperature Table does not apply to flowable concrete fill. The minimum concrete temperature as placed shall be 40°F. No housing framework or heating will be required when placed under approved cold weather conditions.

602.08 Forms and Containment Berms

When necessary to contain flowable concrete fill within a defined area, berms shall be constructed of compacted granular material.

602.09 Placing Flowable Concrete Fill

Flowable concrete fill shall not be placed until forms and/or containment berms have been checked and approved. Flowable concrete fill shall not be placed under water. The method and sequence of placing flowable concrete fill shall be approved by the Resident before any flowable concrete fill is placed.

All flowable concrete fill shall be placed before it has taken its initial set. Flowable concrete fill shall be placed in such a manner as to avoid separation and segregation of the mix. Consolidation, tamping, and vibration is not required or allowed.

Flowable concrete fill shall be discharged directly from the truck into the space to be filled. The drop height of the flowable concrete fill shall be as low as practicable. Flowable concrete fill shall not flow down the vertical face of a trench causing erosion of the trench face. Finishing and curing of flowable concrete fill is not required.

Flowable concrete fill placed will not be opened to traffic or covered with structural concrete or pavement for a minimum of 24-hours.

602.10 Method of Measurement

Flowable Concrete Fill will not require measurement as it is incidental to other Pay Items within the Contract.

SPECIAL PROVISIONSECTION 603PIPE CULVERTS AND STORM DRAINS

(Reinforced Concrete Pipe)
(Concrete Collar)
(Corrugated Polyethylene Pipe)
(Ductile Iron Storm Drain Pipe)

603.01 Description

The following paragraphs are added:

This work shall also consist of furnishing and installing Class III or Class V reinforced concrete pipe at the locations as shown on the Plans or as approved by the Resident. These pipes shall meet the requirements of Subsection 706.02.

This work also consists of furnishing and installing a concrete collar to join existing concrete pipe to the proposed concrete or Corrugated High Density Polyethylene (HDPE) pipe in accordance with the details as shown on the Plans. The Contractor shall note that the concrete pipe ends may be of different sizes and may not fit snugly together.

This work shall also consist of furnishing and installing various sizes of corrugated HDPE pipe, including a dual wall adaptor fittings by Hancor or an approved equal as shown on the plans. No other pipe types within the Option III alternatives will be accepted.

603.02 Materials

Corrugated Steel Pipe is not allowed as an Option III pipe material.

All Corrugated High Density Polyethylene (HDPE) pipe for storm water and drainage systems shall meet the requirements of Subsection 706.06.

Ductile iron storm drain pipe shall be supplied in 18 or 20 foot lengths having Tyton joints or equivalent as specified in ANSI/AWWA C111/A21.11 (for push on joints). Pipe shall be Class 52 unless otherwise specified, Pipe shall be manufactured in full conformance with ANSI/AWWA C151/A21.51 standards. The exterior of the pipe shall be bituminous asphalt coated to 1 mil thick as specified in ANSI/AWWA C151/A21.51. Field application of exterior coatings is prohibited. The finished coating shall be continuous, smooth, neither brittle when cold or sticky when exposed to the sun, and strongly adherent. Pipe shall be furnished with gasket and gasket lubricants as standard accessories.

Push on Joint pipe shall be assembled and installed in strict accordance with the manufacturer's instructions, in accordance with ANSI/AWWA C600, and as described below.

- a. Completely, clean the bell socket and insert the gasket, making sure that it faces the proper direction and that it is correctly seated. Lay pipe with bell ends facing upstream.

b. After cleaning dirt or foreign material from the plain end, apply an approved lubricant in accordance with the pipe manufacturer's recommendations. The lubricant is supplied in sterile cans and every effort shall be made to keep it sterile.

c. Make sure that the plain edge is beveled, square or sharp edges may damage or dislodge the gasket and cause a leak. When pipe is cut in the field, bevel the plain end with a heavy file, grinder or pipe saw to remove all sharp edges.

d. Push the plain end of the pipe into the bell of the pipe. Keep the joints straight while pushing. Make deflection after the joint is assembled. Small pipe can be pushed into the bell socket with a long bar. Large diameter pipe (12" and greater) requires additional power, such as a pipe jack, lever or backhoe. A piece of wood blocking should be used between the pipe and jack or backhoe bucket to avoid damage to the pipe. Care should be taken to avoid "slamming" the pipe together potentially causing a joint failure.

603.11 Method of Measurement

The following paragraph is added:

The Concrete Collar shall be measured by each unit installed, complete in place and accepted. This shall be full compensation for furnishing labor and materials to construct a Concrete Collar to connect the existing and proposed pipe ends in a working like manner, or as a closure pour for concrete pipe culverts where directed by the resident.

Dual Wall Adapter Fitting shall be included for payment as three additional linear feet of the largest pipe involved.

Tees and wyes for ductile iron storm drain pipe shall be included for payment as three additional linear feet of the largest pipe involved. Adaptors if required to connect ductile iron pipe to dissimilar material underdrain pipe are incidental to the pipe and no separate measurement will be made.

603.12 Basis of Payment

Concrete Collars will be paid for at the Contract unit price each regardless of the size of the existing and proposed pipes.

Corrugated HDPE pipe will be paid for under the appropriate sized Culvert Pipe Option III pay items.

Tees and wyes for ductile iron storm drain pipe shall be included for payment as three additional linear feet of the largest pipe involved. Adaptors if required to connect ductile iron pipe to dissimilar material underdrain pipe are incidental to the pipe and no separate payment will be made.

Payment will be made under:

<u>Pay Item</u>		<u>Pay Unit</u>
603.155	12 Inch Reinforced Concrete Pipe - Class III	Linear Foot
603.165	15 Inch Reinforced Concrete Pipe - Class III	Linear Foot
603.175	18 Inch Reinforced Concrete Pipe - Class III	Linear Foot
603.205	30 Inch Reinforced Concrete Pipe - Class III	Linear Foot
603.215	36 Inch Reinforced Concrete Pipe - Class III	Linear Foot
603.2353	48 Inch Reinforced Concrete Pipe - Class V	Linear Foot
603.28	Concrete Collar for Reinforced Concrete Pipe	Each
603.90	12 Inch Ductile Iron Storm Drain	Linear Foot

SPECIAL PROVISION

SECTION 604

MANHOLES, INLETS AND CATCH BASINS

(Catch Basins and Manholes)
(Doghouse Manholes)
(Inlet and Outlet Control Structures)

604.01 Description

This Subsection is amended by the addition of the following:

The work locations are listed on the Drainage Summary sheets of the Plans.

604.02 Materials

The third paragraph should be deleted and replaced with:

Catch Basin Frames and Grates shall be as outlined below and be manufactured by EJ Company of Brockton, Massachusetts or an approved equal and shall meet or exceed the AASHTO M306 Loading Requirements.

Catch Basin Frames shall be manufactured by EJ Company of Brockton, Massachusetts (or an approved equal) with the following product numbers:

5521Z - 8 Inch Frame Product Number 00552111
5546Z – 6 Inch Frame Product Number 00554611
5544Z - 4 Inch Frame Product Number 00554411

Catch Basin Frames shall be 8” frames unless otherwise specified by the plans or approved by the resident.

Catch Basin Grates shall be a square holed grate as manufactured by EJ Company of Brockton, Massachusetts (or an approved equal) with the following product number:

5520M5 Grate Product Number 00552060

If a cascade catch basin grate is specified on the plans then it shall be manufactured by EJ Company of Brockton, Massachusetts (or an approved equal) with the following product numbers depending on the direction of flow:

5520M8 Product Number 00552084 or 5520M8 Product Number 00552085

604.04 Altering, Adjusting, and Rebuilding Catch Basins and Manholes

This Subsection shall be amended with the addition of the following paragraphs:

When adjusting the existing catch basins they shall be dismantled sufficiently to allow reconstruction in accordance with the following requirements and as shown on the Plans:

Any frame or grate damaged by the Contractor's operations shall be replaced by the Contractor at no additional cost to the Authority. Replacement frame and grate shall meet the requirements of Subsection 604.02. Damaged frames and grates shall become the property of the Contractor and shall be removed from Turnpike property.

604.05 Method of Measurement

Section shall be deleted in its entirety and replaced as follows:

Catch basins, manholes, and accessories of the respective types will be measured by the number of units, measures as follows, complete, and accepted in place.

- a. Complete Structures Each structure (catch basin, manhole, inlet, or other) will be measured per each complete and accepted in place.
- b. Existing Structures Existing structures to be altered, adjusted, or modified or rebuilt will be measured per each, regardless of the number of modification, alterations, adjustments made.
- c. Abandon Existing Structures Each existing structure to be abandoned will be incidental to the contract.
- d. Pipe Stub Installation of pipe stubs to connect new structures to existing pipes to remain, will be incidental to the cost of the new structure.
- e. Pipe Caps/Plugs Installation of masonry plugs and caps (for pvc pipes) in existing pipes to be abandoned at proposed structures shall be incidental to the cost of the new structure.

604.06 Basis of Payment

The second paragraph is deleted and replaced with the following:

Excavation and backfill will not be measured separately for payment, but shall be incidental to the following pay items.

Sawing bituminous pavement will not be measured separately for payment, but shall be incidental to the related drainage items.

Payment will be made under:

<u>Pay Item</u>		<u>Pay Unit</u>
604.09	Catch Basin Type B1	Each
604.0901	Catch Basin Type B1 with Flat Top	Each
604.152	48 Inch Manhole	Each
604.1542	72 Inch Outlet Control Structure	Each
604.1561	96 Inch Doghouse Manhole	Each
604.1581	Inlet Control Structure	Each
604.26	Catch Basin Type B5	Each

SPECIAL PROVISION

SECTION 605

UNDERDRAINS

(Tunnel and Tunnel Staircases)

605.02 Materials

The following paragraph is added:

Filter fabric for underdrains shall be Mirafi 160N nonwoven polypropylene geotextile for soil separation and drainage or equivalent meeting the requirements of MaineDOT Standard Specification 722 for both drainage (722.02) and soil separation (722.04).

605.04 Underdrain Construction

The following paragraph is added:

Install filter fabric in accordance with manufacturer's guidelines.

605.07 Basis of Payment

The following paragraph is added:

Filter fabric as well as the aggregate contained within the filter fabric as shown on the drawings will be considered incidental to the cost of underdrains.

SPECIAL PROVISION

SECTION 605

UNDERDRAINS

(8" Underdrain Outlet)

Standard Provisions Apply

605.07 Basis of Payment

The following is added:

Pay Item

Pay Unit

605.105 8 Inch Underdrain Outlet

Linear Foot

SPECIAL PROVISION

SECTION 606

GUARDRAIL

(31" W-Beam Guardrail – Mid-way Splice (7' Steel Posts, 8" Offset Blocks, Single Faced)

606.01 Description

The section is amended by the addition of the following:

This work shall consist of furnishing and installing guardrail components the required locations in accordance with the Specifications and in reasonably close conformity with the lines and grades shown on the Plans. The types of guardrail are designated as follows:

31" W-Beam Guardrail – Mid-way Splice (7' Steel Posts, 8" Offset Blocks)

606.02 Materials

The section is amended by the addition of the following:

Steel posts shall be 7 feet or 8 feet long as specified in the plans.

The guardrail elements shall be per the Components' List found on Sheet No. 2 of 2 of draft Drawing SGR47 – 31" W-Beam Guardrail with Standard 8" Offset Block in the Task Force 13 Report noted above and/or as noted in the Contract Documents unless noted otherwise.

606.04 Rails

The section is amended by the addition of the following:

Height of top of rail shall be 31" measured from final grade. Height transition from 31" W-Beam, mid-spliced guardrail to existing guardrail shall occur over a 25' length.

606.08 Method of Measurement

The section is amended by the addition of the following:

31" W-Beam Guardrail – Mid-way Splice (7' Steel Posts, 8" Offset Blocks) will be paid for at the contract unit price per linear foot of rail satisfactorily installed and accepted.

606.09 Basis of Payment

The section is amended by the addition of the following:

The accepted quantity of 31" W-Beam Guardrail – Mid-way Splice (7' Steel Posts, 8" Offset Blocks) will be paid for at the contract unit price per linear foot of rail and shall be full compensation for furnishing all labor, equipment and materials necessary to complete the work.

Payment will be made under:

Pay Item

Pay Unit

606.13	31" W-Beam Guardrail – Mid-way Splice (7' Steel Posts, 8" Offset Blocks, Single Faced)	Linear Foot
--------	---	-------------

SPECIAL PROVISIONSECTION 606GUARDRAIL

(Bridge Transition - Type III, Modified)

606.01 Description

The following sentence is added:

This work shall consist of furnishing and installing Bridge Transitions - Type III, Modified at concrete median barrier ends along the Turnpike as shown in the Contract Documents.

The following Subsection is added:

606.071 Guardrail Attachments at Concrete Median Barriers

Bridge Transitions - Type III, Modified shall be used at concrete median barrier end locations as shown on the plans.

606.08 Method of Measurement

The following sentence is added:

Bridge Transition- Type III, Modified will be measured by each unit of the type specified, installed and accepted.

606.09 Basis of Payment

The following paragraphs are added:

Bridge Transition - Type III, Modified will be paid for at the Contract unit price each complete in place and shall be full compensation for furnishing all labor, equipment and materials necessary to complete the work consisting of, but not necessarily limited to, the following: furnishing and installing guardrail, modifications to concrete end wall to accept terminal anchor, one terminal connector, precast concrete transition curb, including terminal connector anchorage and all other detailed accessories; furnishing and installing all required posts, rails, offset brackets, back-up lates, nuts, bolts, washers, and all other items necessary to make for a complete installation as shown on the Plans or as approved by the Resident.

Payment will be made under:

<u>Pay Item</u>	<u>Pay Unit</u>
606.1724 Bridge Transition - Type III, Modified	Each

SPECIAL PROVISION

SECTION 606

GUARDRAIL

(Terminal End - Anchored End)
(Terminal End - Anchored End, Thrie Beam)

606.01 Description

The following sentence is added:

This work shall consist of furnishing and installing Terminal End – Anchored End, and Terminal End, Anchored End – Thrie Beam end treatments in accordance with these Specifications, the AASHTO-AGC-ARBTA Joint Committee Task Force 13 Report: A Guide to Standardized Highway Barrier Hardware, dated May 1995; and in reasonably close conformity with the lines and grades as shown on the Plans or as approved by the Resident.

606.02 Materials

The following sentences are added:

The guardrail elements shall be per the Components' List found on Sheet No. 2 of 2 of Drawing SEW02a – Trailing End Terminal – Foundation Tube Option in the Task Force 13 Report noted above and/or as noted in the Contract Documents.

The following Subsection is added:

606.042 Terminal End - Anchored End

Installation of the Terminal End – Anchored End shall be in strict accordance with the AASHTO-AGC-ARBTA Joint Committee Task Force 13 Report and the Details on Sheet No. 1 of 2 of Drawing SEW02a – Trailing End Terminal – Foundation Tube Option.

Height of installation of Terminal End – Anchored End units shall be 27.5-inches to the top of rail, transitioning to the standard height of 30-inches over a 25-foot length of Type 3d rail located immediately after the last post of the Anchored End unit.

Height of installation of Terminal End – Anchored End, Thrie Beam units shall be 32.0-inches to the top of rail, transitioning to the standard height of 30-inches over a 25-foot length of Type 3d rail located immediately after the last post of the Thrie Beam Anchored End unit.

The reveal on the soil tube for the Anchored End units shall not exceed 3.5-inches. If site grading is required to achieve the required rail height and soil tube reveal height, then such work will be incidental to the installation of the Anchored End units.

606.08 Method of Measurement

The second paragraph is amended by the addition of: “, Terminal End - Anchored End,” after the words “breakaway cable terminal”.

606.09 Basis of Payment

The second paragraph is amended by the addition of: “, Terminal End - Anchored End,” after the words “breakaway cable terminal”.

Payment will be made under:

<u>Pay Item</u>		<u>Pay Unit</u>
606.278	Terminal End - Anchored End	Each
606.279	Terminal End - Anchored End, Thrie Beam	Each

SPECIAL PROVISIONSECTION 606GUARDRAIL

(Reflectorized Beam Guardrail Delineator)

606.01 Description

The following paragraphs are added:

Reflectorized beam guardrail delineators shall be installed on existing guardrail to remain in place, guardrail noted to be removed, modified and reset (single and/or double rail) or new guardrail, at the locations noted on Maintenance of Traffic plans or as approved by the Resident. The delineators shall be installed prior to traffic being shifted closer to the identified guardrail run. The color for the reflective sheeting shall be silver (white) when installed on the outside shoulder and yellow when installed on the inside shoulder.

Reflectorized beam guardrail delineators shall be mounted as follows:

1. Delineators on guardrail adjacent to a shifted detour should be spaced every other guardrail post and located at the bolt in the valley of the guardrail beam.
2. On existing steel bridge rail, the delineators shall be mechanically attached towards the top, every 10 feet, and bottom, every 20 feet. Delineators shall also be mechanically attached in a similar pattern to concrete endposts that are 10 feet or longer.
3. If more than 25% of delineators in any 50 feet of guardrail, bridge rail, or endposts fall off for any reason, the Contractor will be responsible for reinstalling all delineators in that run at that their own cost.
4. In no instance shall delineators be installed on guardrail which deviates substantially from the alignment (horizontal or vertical) of the roadway or which is located more than eight feet from the edge of pavement.
5. On Tangents, mount delineators every 62.5-feet or every 10th post.
6. On Curves, mount delineators every 31.25-feet or every 5th post.

Exceptions and/or modifications will only be made with the approval of the Resident.

Contractor is required to submit installation method for review and approval to the Resident.

606.02 Materials

The fourth paragraph is deleted and replaced with the following:

The reflectorized beam guardrail delineators shall be fabricated from galvanized steel.

Reflective sheeting shall meet the requirements of Subsection 719.01, Reflective Sheeting – minimum ASTM Type XI; 3M™ Diamond Grade™ DG³ Reflective Sheeting Series 4000 or approved equal.

606.08 Method of Measurement

The following paragraph is added:

Reflectorized Beam Guardrail Delineators will be measured by each unit of the kind specified and installed. Maintenance and replacement of delineators will not be measured separately for payment unless otherwise approved by the Resident.

606.09 Basis of Payment

The second and third sentences in the first paragraph are deleted and replaced with the following:

Reflectorized Beam Guardrail Delineators will be paid for at the Contract unit price each when installed on existing guardrail, complete in place, which price shall be full payment for furnishing and installing all components and for all incidentals necessary to complete the installation. Reflectorized Beam Guardrail Delineators will not be paid for on new guardrail.

Payment will be made under:

<u>Pay Item</u>	<u>Pay Unit</u>
606.352 Reflectorized Beam Guardrail Delineator	Each

SPECIAL PROVISIONSECTION 606GUARDRAIL

(Underdrain Delineator Post)
(Delineator Post – Remove and Stack)

606.01 Description

The following paragraphs are added:

This work shall also consist of furnishing and installing new delineator posts and/or removing and resetting and/or removing and stacking existing delineator posts at the Kennebunk Maintenance Facility. The existing reflectorized delineator panels shall be removed and replaced with new reflectorized delineator panels as required by the Resident.

Existing and new delineator posts shall be located as follows, with the indicated panel:

Outside Shoulder:

- One at guardrail trailing ends (green delineator).
- Two at guardrail approach ends (one red delineator on first post and one red delineator on angle points.)

Median:

- One at guardrail trailing ends (green delineator, facing traffic).
- Two at guardrail approach ends (one red delineator on first post of CAT units, green on guard rail side, red on median opening side; and one red (both sides) delineator at angle point.)
- One at all other median guardrail angle points (red on both sides)

Other Locations:

- One at culvert outlets (green delineator).
- Twenty per mile evenly spaced at the edge of outside shoulder (white delineator).
- One at electrical junction boxes not associated with another item (red delineator).
- One at communication only junction boxes not associates with another item (orange delineator).

Delineator posts that do not exist in the locations described above shall be supplied and installed by the Contractor. The installation of the delineator post shall include the demountable reflectorized delineator panel.

White edge delineators shall not be installed on any portion of the widened shoulder for Energy Absorbing End Terminal installations, and shall not be installed behind the terminal end rail segments.

606.02 Materials

The following paragraphs are added:

Non-guardrail Delineator Posts shall conform to Subsection 606.02 paragraph 3.

The seventh through ninth sentences of the fourth paragraph are deleted and replaced with the following:

Reflectorized flexible guardrail markers shall be a minimum of 2-inches in diameter, a maximum of 36" in length, ovalized at the top of the post to allow application of 3 inch by 9 inch high intensity reflective sheeting, and shall be capable of recovering from repeated impacts. The flexible guardrail delineator markers shall be grey and capped at the top with a flexible rubber cap; Safe-Hit Flexible Guardrail Delineator or approved equal. Reflective material shall meet the requirements of ASTM Type IX Diamond Grade VIP (Visual Impact Performance).

The demountable reflectorized delineator panels shall meet the material requirements of Subsection 719.06. The delineator panel shall be rectangles measuring 9" x 3".

606.03 Posts

The following paragraphs are added:

The top of delineator posts shall be installed 4' - 6" (54") above edge of pavement elevation. Delineators shall be installed four feet from edge of pavement except those delineating end treatments, culverts and electrical items.

Mile marker posts shall be mounted on breakaway supports. The bottom of the sign shall be 5' - 0" (60") above the pavement at the solid white line and shall be offset five feet from the edge of pavement.

A mock-up of the guardrail delineator posts shall be submitted to the Resident for approval prior to installation.

Any materials damaged by the Contractor's operations shall be replaced at no additional cost to the Authority.

Top of the delineator panel shall be flush with the top of post.

606.08 Method of Measurement

The following paragraphs are added:

Delineator Posts shall be measured by each unit satisfactorily installed. Delineator Posts – Removed and Reset shall be measured by each unit satisfactorily removed and reset. Delineator Posts – Removed and Stacked shall be measured by each unit satisfactorily removed and stacked.

Mile Marker post shall be measured for payment as Delineator Post. The breakaway supports shall be incidental to the Underdrain Delineator Post pay item.

606.09 Basis of Payment

The following sentences are added:

The accepted quantity of Delineator Posts will be paid for under the Underdrain Delineator Post item, at the Contract unit price per each which price shall be full compensation for the post and specified delineator or mile marker panel, complete in place.

The accepted quantity of Delineator Post – Removed and Reset will be paid for at the Contract unit price per each, which price shall be full compensation for removing and resetting the delineator panel or mile marker panel and post and all incidentals necessary to complete the work.

The accepted quantity of Delineator Post – Removed and Stacked will be paid for at the Contract unit price per each, which price shall be full compensation for removing and stacking the delineator panel or mile marker panel and post and all incidentals necessary to complete the work.

Payment will be made under:

<u>Pay Item</u>	<u>Pay Unit</u>
606.3562 Delineator Post – Remove and Stack	Each

SPECIAL PROVISION

SECTION 606

GUARDRAIL

(Guardrail – Remove, Modify and Reset, Single Rail)
(Guardrail – Remove, Modify and Reset Thrie Beam, Double Rail)
(Guardrail – Remove, Modify and Reset Thrie Beam, Single Rail)

606.01 Description

The following paragraphs are added:

This work shall also consist of removing existing single and double guardrail elements, component parts and hardware suitable for replacement as approved by the Resident. Any guardrail elements, posts, component parts and hardware unsuitable for reuse shall become property of the Contractor.

Stockpiled materials, suitable for reuse, shall be utilized on Remove, Modify and Reset items prior to new materials being paid for.

Guardrail materials may be temporarily stockpiled at the Kennebunk Maintenance Facility.

This work shall consist of removing, disposing of existing guardrail elements, component parts and hardware, as directed by the Resident. All materials shall become the property of the Contractor and shall be removed from the site at the completion of the Project. The Contractor shall provide the Resident with an affidavit stating the final location of all disposed material and that the material was disposed of in accordance with the Maine Department of Environmental Protection Solid Waste Regulations.

606.02 Materials

The following paragraph is added at the end of the subsection:

New non-wood offset blocks conforming to NCHRP 350 Test Level 3 shall be installed on all guardrail being reset. The existing steel offset brackets and backup plates shall become the property of the Contractor.

The following Subsection is added:

606.021 General

All existing guardrail to be raised or lowered shall be completed prior to new guardrail or end treatments being attached.

Earth around each adjusted or reset post shall be raked and compacted with a minimum 8-pound hand tamper or an approved device. Holes created due to adjusting or resetting a post shall be filled with a similar surrounding material and compacted.

606.08 Method of Measurement

The following paragraphs are added:

Raking and compacting the earth around each reset post with a minimum 8-pound hand tamper or an approved device, and infilling and compacting holes created due to resetting posts with a similar surrounding material will not be paid separately, but shall be incidental to the Guardrail - Remove, Modify and Reset pay items.

Guardrail removed and not reset or stacked shall be incidental to Contract Items and include all removal, disposal, equipment and labor necessary to satisfactorily complete the work.

Steel posts to replace damaged posts shall come from the stockpile of guardrail components to be disposed of, from this Contract and will not be measured separately for payment. If, in the opinion of the Resident, there are no suitable steel posts in the stockpile then steel posts will be measured for payment.

W-beam rail elements to replace damaged rail elements shall come from the stockpile of guardrail from the Remove and Stack or the guardrail to be disposed of from this Contract and will not be measured separately for payment. If, in the opinion of the Resident, there are no suitable W-beam rail elements in the stockpile then the W-beam rail elements will be measured for payment.

606.09 Basis of Payment

The following paragraphs are added:

The removing and disposing of all guardrail elements, component parts and hardware not used for resetting the guardrail shall be included in the Contract Unit Price bid for Remove, Modify, and Reset guardrail items. Stockpiling existing rail elements, posts, and component parts will not be measured separately for payment, but shall be incidental to the guardrail items.

Payment will be made under:

<u>Pay Item</u>	<u>Pay Unit</u>
606.3605 Guardrail – Remove, Modify, and Reset, Single Rail	Linear Foot
606.3610 Guardrail – Remove, Modify, and Reset Thrie Beam, Single Rail	Linear Foot
606.3611 Guardrail – Remove, Modify, and Reset Thrie Beam, Double Rail	Linear Foot

SPECIAL PROVISIONSECTION 606GUARDRAIL

(Guardrail – Remove and Stack or Dispose)

606.01 Description

The following paragraph is added:

This work shall consist of removing and stacking or disposing of existing single and double guardrail elements, component parts and hardware as approved by the Resident. The Resident shall designate which existing guardrail shall be stacked and which existing guardrail shall be disposed of. Guardrail to be stacked shall be transported and delivered to the Kennebunk Maintenance Area. All remaining existing unsuitable guardrail elements, posts, component parts and hardware shall become the property of the Contractor and shall be removed from turnpike property. The Contractor shall provide the Resident with an affidavit stating the final location of all disposed material and that the material was disposed of in accordance with the Maine Department of Environmental Protection Solid Waste Regulations

606.8 Method of Measurement

The following paragraph is added:

Guardrail – Remove and Stack or Dispose will be measured on a linear foot basis of guardrail satisfactorily Removed and Stacked or Disposed, whether single rail or double rail. Double twisted end sections will be measured for payment on a linear foot basis as 25 feet of guardrail removed.

606.9 Basis of Payment

The following paragraphs are added:

The accepted quantity of Guardrail - Remove and Stack or Dispose will be paid for at the Contract unit price bid per linear foot, which price shall be full compensation for removing, stacking, transporting, and/or disposing all guardrail elements, component parts and hardware, equipment, labor and all incidentals necessary to complete the work. No additional payment will be made for double rail. Stockpiling existing rail elements, posts, and component parts will not be measured separately for payment, but shall be incidental to Item 606.3631.

Payment will be made under:

Pay ItemPay Unit

606.3631	Guardrail – Remove and Stack or Dispose	Linear Foot
----------	---	-------------

SPECIAL PROVISIONSECTION 606GUARDRAIL

(Widen Shoulder for Energy Absorbing End Terminal)

606.01 Description

The following sentence is added:

Widen Shoulder for Energy Absorbing End Terminal work shall consist of widening the existing shoulder at specified Energy Absorbing End Terminal locations by excavating, furnishing, grading and compacting new shoulder aggregate subbase course gravel, granular borrow, common borrow, and asphalt grindings in accordance with the thickness and typical sections as shown on the Plans or as approved by the Resident.

The following Subsections are added:

606.021 Granular Borrow

Granular borrow shall be material meeting the requirements of Subsection 703.19.

606.022 Fill Material

Fill material shall be existing excavation or common borrow from an outside source.

606.023 Asphalt Grindings

Asphalt grindings shall consist of pavement millings created by the cold planning process. The asphalt grindings stockpile must be viewed and approved by the Resident prior to any grindings being placed at any location.

The grindings shall be reprocessed (crushed) to meet the following gradation:

SIEVE DESIGNATION	GRADING
3/4"	100
1/2"	95 - 100
No. 4	50 - 80
No. 50	18 - 28
No. 200	3 - 10

606.024 Aggregate Subbase Course-Gravel

Aggregate subbase course-gravel shall be material meeting the requirements of Subsection 703.06.

606.051 Compaction - Asphalt Grindings

The asphalt grindings shall be placed and compacted to a minimum thickness of three inches unless otherwise designated by the Resident.

606.08 Method of Measurement

Widen Shoulder for Energy Absorbing End Terminal will be paid at the contract unit price per each.

Common borrow will be measured in accordance with Section 203 of these Specifications.

Loam, seed and mulch will not be measured separately but shall be incidental to the Widen Shoulder for Energy Absorbing End Terminal pay item and the Modify Widened Shoulder for Energy Absorbing End Terminal.

606.09 Basis of Payment

The following paragraphs are added:

The accepted quantity of Widen Shoulder for Energy Absorbing End Terminal shall also include the excavation, asphalt grindings, aggregate subbase course gravel, granular borrow, loam, seed, fertilizer, and mulch.

Common borrow will be measured in accordance with Section 203 of these Specifications.

Payment will be made under:

<u>Pay Item</u>	<u>Pay Unit</u>
606.754 Widened Shoulder for Energy Absorbing End Terminal	Each

SPECIAL PROVISIONSECTION 606GUARDRAIL

(Guardrail – Flared Terminal – 31” W-Beam Guardrail)

606.01 Description

The following sentences are added:

This work shall consist of furnishing and installing a FLEAT (Flared Energy Absorbing Terminal) for use with the 31” W-Beam Guardrail – Mid-way Splice (7’ Steel Posts, 8” Offset Blocks, Single Faced) as manufactured by Road Systems, Inc., 1507 East 4th Street, Big Spring, Texas 79720, (915) 263-2435, and retroreflective adhesive sheeting in accordance with these Specifications and the manufacturer’s installation instructions, and in reasonably close conformity with the lines and grades as shown on the Plans or as approved by the Resident.

606.02 Materials

The following sentence is added:

Guardrail – Flared Terminal – 31” W-Beam Guardrail components shall be comprised of those shown in the manufacturers installation instructions. 8” blocks shall be used.

Reflective sheeting shall meet the requirements of Subsection 719.01, Reflective Sheeting – minimum ASTM Type XI; 3M™ Diamond Grade™ DG³ Reflective Sheeting Series 4000 or approved equal, color WHITE.

The contractor shall request for the impact face object marker, black chevron on yellow background, to be included in the shipped materials when installation is on the left side of roadway.

The following Subsections are added:

606.03 Posts

Wood offset blocks shall be toe-nailed in two locations to the wood post to prevent the blocks from moving.

606.035 Construction Requirements

The Contractor shall submit a set of installation drawings to the Resident for approval. The system shall be installed in accordance with the manufacturer’s recommendation and the installation drawings.

A reflective adhesive sheeting shall be applied to the nose of the FLEAT System after installation. The existing sheeting shall be replaced on FLEAT systems to be removed, modified, and reset. Color – WHITE.

606.041 Reflective Sheeting

The color for the reflective sheeting shall be silver (WHITE) when installed on the outside shoulder and shall be black chevron on yellow background only when installed on the inside shoulder.

606.08 Method of Measurement

The second paragraph is amended by the addition of: “Guardrail – Flared Terminal – 31” W-Beam Guardrail, ” after the words “Terminal section, ”.

Guardrail – Flared Terminal – 31” W-Beam Guardrail will be measured by each unit satisfactorily complete in place and accepted.

606.09 Basis of Payment

The first paragraph is amended by the addition of: “Guardrail – Flared Terminal – 31” W-Beam Guardrail, ” after the words “Terminal section, ”.

The second paragraph is amended by the addition of: “, Guardrail – Flared Terminal – 31” W-Beam Guardrail, and ” after the words “NCHRP 350 end treatments ”.

The retroreflective sheeting will not be measured separately for payment, but shall be incidental to the Guardrail – Flared Terminal – 31” W-Beam Guardrail item.

Payment will be made under:

<u>Pay Item</u>	<u>Pay Unit</u>
606.791 Guardrail – Flared Terminal – 31” W-Beam Guardrail	Each

SPECIAL PROVISION

SECTION 607

FENCES

(Dumpster Enclosure)

607.01 Description

The following paragraphs are added:

This work shall consist of installing a Dumpster Enclosure of dimensions conforming to the Plans and at the location depicted on the Plans.

The installation shall include the assembly and erection of all parts and materials complete at the location as shown on the Plans.

607.02 Materials

The following sentences are added:

Privacy Slats shall be UV light stabilized fiber-glass reinforced plastic slats, not less than 0.06 inches thick, size to fit mesh specified for direction indicated. Color shall be as indicated on the drawings.

Polymer Coated Fabric shall be per ASTM F668, Class 1 over zinc coated steel wire. Color shall be as indicated on the drawings.

607.05 Chain Link Fence

The following sentences are added:

e Privacy Slats: Privacy slats shall be installed in a vertical direction, per manufacturer's recommendations.

607.06 Method of Measurement

Dumpster Enclosure will be measured by each unit of the kind specified and installed.

607.07 Basis of Payment

Dumpster enclosure will be paid for at the Contract lump sum price, complete in place, which payment shall be compensation for furnishing and installing fence enclosure panels/slats with necessary hardware, excavation, concrete, and backfill.

Payment will be made under:

Pay Item

Pay Unit

607.4211 Dumpster Enclosure

Lump Sum

SPECIAL PROVISIONSECTION 607FENCES

(Pipe Entry Gate)

607.01 Description

The following paragraphs are added:

This work shall also consist of installing a pipe entry gate in reasonably close conformity with the lines and grades as shown on the Plans or as approved by the Resident.

The installation shall include the assembly and erection of all parts and materials complete at the locations as shown on the Plans or as approved by the Resident.

607.02 Materials

The following sentences are added:

The pipe entry gate width is designated on the Plans.

Pipe entry gate and associated hardware shall be of galvanized steel as specified in AASHTO M181 and shall be galvanized in accordance with the applicable requirements of ASTM A153.

607.06 Method of Measurement

Pipe Entry Gate will be measured by each unit of the kind specified and installed.

607.07 Basis of Payment

Pipe Entry Gate will be paid for at the Contract price each, complete in place, which payment shall be compensation for furnishing and installing all necessary hardware, excavation and concrete.

Payment will be made under:

<u>Pay Item</u>	<u>Pay Unit</u>
607.2325 Pipe Entry Gate	Each

SPECIAL PROVISION

SECTION 607

FENCES

(ROW Fence with Habitat Barrier Fence)

607.01 Description

The following paragraph is added:

Construct Right of Way Fence with Habitat Barrier Fence as indicated on plans or as directed by Resident.

607.07 Method of Measurement

The following paragraph is added:

Right of Way Fence with Habitat Barrier Fence, Metal Posts will be measured by the linear foot accepted in place. Measurement will be along the gradient of the fence from outside to outside of end posts for each continuous run of fence and shall include fence at bracing assemblies and embedment of the barrier mesh as shown on the details.

607.08 Basis of Payment

The following paragraphs are added:

The accepted quantities of Right of Way Fence with Habitat Barrier Fence, Metal will be paid for at the contract unit price per linear foot. Payment shall be full compensation for furnishing and assembling all materials inclusive of bracing materials and posts, for excavating and backfilling holes, excavation and backfill to embed the barrier mesh as shown on the details and for all incidentals necessary to complete the work.

Clearing or removing of trees, stumps or boulders, required to install the fence shall be included in the work of pay items under this section.

Payment will be made under:

Pay Item

Pay Unit

607.093 Right of Way Fencing with Habitat Barrier Fence, Metal Posts

Linear Foot

SPECIAL PROVISION

SECTION 607

FENCES

(Chain Link Fence – 3’ High)
 (Post Assemblies for Chain Link Fence – 3’ High)

607.01 Description

The following paragraph is added:

The work shall consist of fabricating and erecting 3’-0” high barrier mounted chain link fence and barrier mounted post assemblies for support of chain link fence and/or road signs as shown on plans.

607.02 Materials

The following paragraph is added:

All materials for the chain link fence and Post Assemblies shall be hot dip galvanized after fabrication in accordance with ASTM A123 or A153 as applicable.

All anchor bolts shall be drilled and anchored into concrete barrier using an approved chemical anchoring material selected from the Maine DOT list of qualified anchoring materials. The use of cementitious grouts will not be allowed.

607.06 Method of Measurement

The following paragraphs are added:

Post Assemblies for Sign or Chain Link Fence shall be measured by each unit satisfactorily fabricated and installed.

607.07 Basis of Payment

The following paragraphs are added:

Payment for Post Assembly for Sign or Chain Link Fence shall include furnishing and installing anchor rods and related hardware required to fasten the post assemblies to the precast barrier.

Payment will be made under:

<u>Pay Item</u>		<u>Pay Unit</u>
607.40	Chain Link Fence – 3’ High	Linear Foot
607.41	Post Assembly for Sign Or Chain Link Fence	Each

SPECIAL PROVISIONSECTION 608SIDEWALKS(Reinforced Concrete Sidewalks)(Reinforced Concrete Site Slabs)

The provisions of Section 608 of the Standard Specifications shall apply with the following additions and modifications.

608.01 Description

Delete this section in its entirety and replace as follows:

This work shall consist of furnishing all materials for and constructing sidewalks and site slabs of concrete, in conformance with this specification and all other applicable Contract Documents.

608.021 Sidewalk Materials

Revise this section by removing the second paragraph which begins with “Portland cement concrete shall...” in its entirety and replace with “Portland cement concrete shall be Class A and meet the requirements of Supplemental Specification Section 502 – Structural Concrete.”

608.031 Portland Cement Concrete Sidewalks

Subsection “c.” – Placing Concrete

Revise this section by removing the second sentence which begins with “The proportioning, mixing, and placing...” in its entirety and replace with “The proportioning, mixing, and placing of the concrete shall be in accordance with the requirements of Supplemental Specification Section 502 – Structural Concrete.”

608.035 Construction Sidewalk

Revise this by adding the following at the end of the first sentence, “This work shall be considered incidental to the 608.08 item and no separate measurement or payment will be made.”

608.05 Method of Measurement

Section shall be deleted in its entirety and replaced as follows:

Reinforced Concrete Sidewalks/Site Slabs will be measured by the square-yard of finished surface, complete in place. Construct sidewalks is incidental to the sidewalk/site slab item and no separate measures will be made.

608.06 Basis of Payment

Section shall be deleted in its entirety and replaced as follows:

The accepted quantity of concrete sidewalk/site slabs will be paid for at the contract unit price per square yard. Expansion joint material, joint filler, and other related items will not be paid for separately but the cost, thereof, shall be included in the cost of the sidewalk.

The Contractor is responsible for protecting cast-in-place concrete from vandalism until it is cured. No payment will be made for concrete that has been vandalized by inscribed initials, footprints and hand prints, embedded items or other acts of vandalism.

For constructing sidewalk, the cost for excavation, furnishing and placing new aggregate and necessary incidentals to bring the grade to prepave/preplacement grade is incidental to the sidewalk items and no separate payment will be made.

Payment will be made under:

<u>Pay Item</u>	<u>Pay Unit</u>
608.08 Reinforced Concrete Sidewalk/Site Concrete Slabs	Square Yard

SPECIAL PROVISION

SECTION 610

STONE FILL, RIPRAP, STONE BLANKET AND STONE DITCH PROTECTION

(Temporary Stone Check Dams)

(Permanent Stone Check Dams)

610.01 Description

Paragraphs (g) and (h) are added as follows:

(g) Temporary Stone Check Dams – Machine placed stone, including the placement, removal and storage of the stone used for temporary stone check dams.

(h) Permanent Stone Check Dams – Machine placed stone used for temporary stone check dams.

610.032.e. Stone Check Dams

The following paragraph is added:

Stone check dams shall be constructed in accordance with the details as shown on the Plans, detailed in the MaineDOT's latest Best Management Practices, or as approved by the Resident. The stone shall be placed in one operation without special handling or handwork except to create a low point along the top gradient above the ditch flow lines.

The following Subsection is added:

610.033 Removing Stone

The stone for temporary stone check dams shall be removed after vegetation has been established in the ditches as approved by the Resident.

Any damage to the slopes and ditches caused by the removal of the stone check dams shall be repaired by the Contractor at his own expense.

The area directly under the temporary stone check dams shall be loamed, seeded and mulched immediately after the removal of the stone check dams. The loam, seed and mulch will be measured for payment under the appropriate pay items.

Stone used for temporary stone check dams shall be removed and stored and shall become the property of the Contractor at the completion of the Project.

The following Subsection is added:

610.034 Maintenance

Stone check dams shall be maintained by the Contractor. Sediment deposits behind check

dams shall be removed when the depth of sediment reaches 50 percent of the check dam height.

610.05 Method of Measurement

The following paragraphs are added:

Stone for Temporary Stone Check Dams will be measured by the cubic yard complete in place. The removal and storage of the stone will not be measured separately for payment, but shall be incidental to the Temporary Stone Check Dam item. This shall include the transporting and unloading of the stone. If this stone is reused on the Project, it will be measured separately for payment under the appropriate pay item.

The removal and disposal of sediment from behind the Temporary Stone Check Dams will not be measured separately for payment, but shall be incidental to the Temporary Stone Check Dam pay item.

Stone for Permanent Stone Check Dams will be measured by the cubic yard complete in place. This shall include the transporting and unloading of the stone.

610.06 Basis of Payment

The following sentences are added:

The accepted quantities of stone for Stone Check Dams will be paid for at the Contract unit price per cubic yard.

Payment will be made under:

<u>Pay Item</u>		<u>Pay Unit</u>
610.181	Temporary Stone Check Dam	Cubic Yard
610.182	Permanent Stone Check Dam	Cubic Yard

SPECIAL PROVISION

SECTION 619

MULCH

(Temporary Mulch)
(Bark Mulch)

619.01 Description

The first paragraph is modified by the addition of the following:

“as a temporary or permanent erosion control measure” after the word “mulch”.

619.03 General

The first paragraph is deleted and replaced with the following:

Cellulose fiber mulch shall not be used within 200 feet of a wetland or stream. The limits shall be 200 feet upstation and downstation of the wetland or streams as well as the slopes adjacent to the stream. The application of hay or straw mulch with an approved binder shall be used at these locations to prevent erosion.

The use of cellulose fiber mulch will only be allowed at other areas with the approval of the Resident. The Contractor may be required to demonstrate that the material may be applied in a manner that will prevent erosion and will aid in the establishment of permanent vegetation. The Resident reserves the right to require the use of hay or straw mulch at all locations if he determines that the cellulose mulch is ineffective. Cellulose fiber mulch is not acceptable for winter stabilization.

619.04 Applying Mulch

The third paragraph is deleted and replaced with the following:

Newly disturbed earth and ditches shall be mulched or otherwise stabilized by the end of each work day and maintained on a daily basis as described in Subsection 105.8.1.11 (b) in the Special Provisions. The Contractor is responsible for applying temporary mulch as necessary, in accordance with the latest edition of the BMP's, to minimize soil erosion prior to the application of the final slope treatment.

Temporary mulch applied during the winter months of November 1st through April 15th shall be applied at twice the standard temporary stabilization rate or 150 lbs. per 1,000 square feet or three tons/acre. Mulch shall not be spread on top of snow and shall be anchored with mulch netting on slopes steeper than eight percent unless erosion control blankets or erosion control mix is being used on the slopes.

The Contractor shall review his construction operations and staging to determine how much temporary mulching is required.

619.06 Method of Measurement

The following sentence is added:

Temporary Mulch will be paid for by the lump sum.

619.07 Basis of Payment

The following paragraphs are added:

Temporary Mulch will be paid for at the Contract price per lump sum which shall be full compensation for furnishing and spreading the Temporary Mulch as many times as necessary as determined by the Contractor's operations and staging. The price shall also include the additional mulch netting and snow removal necessary during the winter months.

Payment will be made under:

Pay Item

Pay Unit

619.1202 Temporary Mulch
 619.13 Bark Mulch

Lump Sum
 Cubic Yard

SPECIAL PROVISIONSECTION 621LANDSCAPING(Evergreen Trees)(Deciduous Trees)(Deciduous Shrubs)

The provisions of Section 621 of the Standard Specifications shall apply with the following additions and modifications:

621.0001 Description

This work shall consist of the Contractor furnishing and planting trees, shrubs, vines, and other plants and shall include all planting operations and material as well as the care and replacement of the plants during the establishment period, all in accordance with the specifications, planting plans and schedules and the directions of the Resident.

Landscaping shall include the placement of loam and mulch in planting best as shown on the drawings.

621.0036 Establishment Period

Contractor shall adhere to all provisions of 621.0036.

621.0037 Method of Measurement

The quantity of plants to be measured for payment shall be the number of individual plants furnished and planted as required and accepted excluding replacements.

Wood fiber mulch for the planting and tree areas is to be incidental to the installation of the landscape plants. No separate measurement or payment will be made.

621.0038 Basis of Payment

Each item of "Planting shall be paid for at the contract unit price for each accepted plant furnished and placed. Payment shall constitute full compensation for; furnishing and placing plants, digging, delivering, rodent protection, preparing plant pits, beds and drains; planting, watering, fertilizing, mulching, pruning, and the cleanup of planting areas; for all, fertilizer, mulch and other necessary materials; all labor, equipment, tools, Maintenance Period work, Replacement and Bonding (if required by Special Provision) and any other incidentals necessary to complete the work.

When a bid item calls for a "Group" of trees, shrubs, vines or other plants, the Contractor shall furnish each individual species within this "Group" for the same unit bid price.

The name and estimated number of individual species within each "Group" will be shown on the estimated quantities on the plans.

Payment will be made under:

<u>Pay Item</u>	<u>Pay Unit</u>
621.037 Evergreen Tree (5'-6'), Group GP A <i>Thuja O. Douglass (Douglass Arborvite)</i>	Each
621.291 Large Deciduous Tree (4" cal.), GP A <i>Nyssa Sylvatica (Tupelo)</i>	Each
621.535 Deciduous Shrub (No. 3 Cont), GP A <i>Dievilla Lonicera (Bush Honeysuckle)</i> <i>Myrica Gale (Sweetgale)</i>	Each

SPECIAL PROVISION

SECTION 625

WATER SERVICE SUPPLY LINES

(2-Inch Copper Tubing)
(2-Inch Non Metallic Pipe)
(8-Inch non Metallic Pipe Sleeve)

625.01 Description

This work shall consist of providing and installing high density polyethylene water service pipe and high density polyethylene pipe sleeve as shown on the plans.

625.02 Materials

Materials shall conform to the requirements as indicated below:

Water Service (Metallic)

1. Material:

- A. Type K malleable Copper Tubing conforming to ASTM Standard B-88 and the attest revision of AWWA Standard C800

Water Service (non Metallic)

1. Material:

- A. High Density Polyethylene Pipe, Copper Tube Size

2. Diameter:

- A. Copper Tube Size
- B. The I.D. shall be a minimum of 1.62”
- C. The O.D. shall be a maximum of 2.125”
- D. The minimum wall thickness shall be 0.236”

3. Pressure Rating:

- A. The minimum working pressure rating shall be 200 PSI (SDR-9)
- B. The pipe shall conform to AWWA C901

Pipe Sleeve

1. Material:

- A. High Density Polyethylene Pipe, Ductile Iron Pipe Size

2. Diameter:

- A. Ductile Iron Pipe Size
- B. The I.D. shall be a minimum of 6.917”
- C. The O.D. shall be a maximum of 9.050”
- D. The minimum wall thickness shall be 1.006”

3. Pressure Rating:

- A. The minimum working pressure rating shall be 250 PSI (SDR-9)
- B. The pipe shall conform to standard AWWA C901

Pipe Insulators

1. Polyethylene Casing Insulators
2. Dielectric Strength (ASTM D-149): 450-500 Volts/Mil
3. Flexural Strength (ASTM D-790): 4600psi
4. Compressive Strength (ASTM D-695): 4600psi
5. Tensile Strength (ASTM D-638): 4600psi
6. Water Absorption (ASTM D-570): <0.01%
7. Impact Strength (ASTM D-256) 1.3 ft.lb/in
8. Maximum Continuous Operating Temperature: 180° F

625.03 Method of Measurement

Pipe sleeve, metallic pipe and non-metallic pipe will be measured by the linear foot.

625.04 Basis of Payment

The accepted quantities of pipe sleeve, metallic pipe and non-metallic pipe will be paid for at the contact unit price per linear foot for the types and sizes specified complete and accepted in place, which payment will be compensation for furnishing and installing all necessary fittings for connecting to supply water main and service facility. Compensation shall also include coordinating with any regulatory agency/district having jurisdiction including but not limited to York Water District, and performing all necessary testing procedures required by agencies for acceptance of installation.

Excavation, backfill and compaction will not be paid for separately, but will be considered included in the work of the contract items.

Pipe Insulators and end skirts shall be considered included in the contract unit price for the pipe sleeve item.

Payment will be made under:

<u>Pay Item</u>		<u>Pay Unit</u>
625.086	2 Inch Copper Tubing	Linear Foot
625.16	2 Inch Non-Metallic Pipe	Linear Foot
625.145	8 Inch Non-Metallic Pipe Sleeve	Linear Foot

SPECIAL PROVISION

SECTION 626

FOUNDATIONS, CONDUIT, AND JUNCTION BOXES
FOR HIGHWAY SIGNING, LIGHTING AND SIGNALS

(4'x 4' Splice Box)

626.02 General

The following paragraphs are added:

4'x4' Splice Boxes for telecommunications and data shall be two-piece precast concrete units with a separate base slab. Concrete shall have a minimum compressive strength of 5,000 psi at 28-days and rated for H-20 loading. Boxes shall have a minimum clear opening of 4'x4' with a wall thickness of 5-inches.

Splice box frame and cover shall be rated for H-20 loading and shall be manufactured by EJ Company of Brockton, Massachusetts (or an approved equal) with the following product numbers:

1810 5-58" Tall Manhole Assembly Communication Product Number 00182018

626.04 Method of Measurement

The following sentence is added:

4'x4' Splice Box shall be measured by each unit complete in place and accepted. Furnishing and installing splice box access frame and cover shall be considered incidental to pay item 626.13 and no measurement will be required.

626.05 Basis of Payment

The following sentence is added:

The accepted quantity of 4'x4' Splice Box will be paid for at the Contract Unit Price per each. Payment shall include furnishing and installing the precast concrete splice box, manhole frame and cover and all materials and labor needed to complete the work. Excavating and backfilling for splice boxes will be considered incidental to the pay item. Rock excavation, if required for installation will be paid under item 206.07 Structural Rock Excavation- Drainage and Minor Structures.

Payment will be made under:

Pay Item

Pay Unit

626.113	4'x4' Splice Box	Each
---------	------------------	------

SPECIAL PROVISIONSECTION 626FOUNDATIONS, CONDUIT, AND JUNCTION BOXES
FOR HIGHWAY SIGNING, LIGHTING AND SIGNALS

(Primary Electric Manhole (CMP))

626.02 General

The following paragraphs are added:

Primary Electric Manhole for electricity shall be a two-piece precast concrete unit of dimensions depicted within the drawings. Concrete shall have a minimum compressive strength of 5,000 psi at 28-days and rated for H-20 loading.

Manhole frame and cover shall be rated for H-20 loading and as shown on the details.

626.04 Method of Measurement

The following sentence is added:

Primary Electric Manhole shall be measured by each unit complete in place and accepted. Providing and installation electrical manhole frame and cover shall be considered incidental to pay item 626.13 and no measurement will be required.

626.05 Basis of Payment

The following sentence is added:

The accepted quantity of Primary Electric Manholes will be paid for at the Contract Unit Price per each. Payment shall include furnishing and installing the precast concrete manhole, manhole frame and cover and all materials and labor needed to complete the work. Excavating and backfilling for manholes will be considered incidental to the pay item. Rock excavation, if required for installation will be paid under item 206.07 Structural Rock Excavation- Drainage and Minor Structures.

Payment will be made under:

<u>Pay Item</u>		<u>Pay Unit</u>
626.13	Primary Electric Manhole (CMP)	Each

SPECIAL PROVISION

SECTION 626

FOUNDATIONS, CONDUIT, AND JUNCTION BOXES
FOR HIGHWAY SIGNING, LIGHTING AND SIGNALS

(Non Metallic Conduit, Concrete Encased)

626.01 Description

The following paragraph is added:

“This work shall consist of furnishing and installing concrete encased nonmetallic conduit as shown on the plans.”

626.021 Miscellaneous Materials

The following paragraph is added:

“All concrete for concrete encasement of conduit shall be Fill Class concrete in accordance with the applicable requirements of Section 502 – Structural Concrete.”

626.031 Conduit

Revise the fifth paragraph which begins with “After the trench has been...” by adding the following to the end of it:

“Where concrete encasement is required around the conduit, backfilling with approved material may begin adjacent to and above the encased conduit no sooner than 24 hours after concrete placement.

Concrete encasement shall consist of a minimum of 4 inches of concrete above, below and on both sides of the conduit that shall have a minimum compressive strength of 3000 psi and a maximum aggregate size of 1-inch (Fill Class concrete). The concrete encasement may be backfilled no sooner than 24 hours after placement.

Reinforcing bar size and spacing shall be provided in accordance with the utility provider’s specifications and standard details.

Concrete encasement shall include #4 bare copper ground wire within the duct bank as shown on the details”

626.04 Method of Measurement

The following paragraph is added:

“Concrete encasement, reinforcing and grounding wire for concrete encased conduit is incidental to the linear foot price of the conduit and no separate measurement will be made.”

626.05 Basis of Payment

Amend the third paragraph which reads “Payment will be made for the total number of linear feet of each type of underground or exposed conduit actually furnished, installed, and accepted at the contract price per linear foot. This price shall include the cost of: furnishing and installing the conduit; excavating; furnishing special backfilling materials, pull wire, fittings, groundings and bonding; test cleaning interiors of conduits and all materials, labor, equipment and incidentals necessary to complete the work.” by adding the following to the end of it:

“This price shall include furnishing and installing concrete encasement, reinforcing bars and grounding wire.”

Payment will be made under:

<u>Pay Item</u>		<u>Pay Unit</u>
626.2214	4” Non-Metallic Conduit, Concrete Encased	Linear Foot
626.2215	5” Non-Metallic Conduit, Concrete Encased	Linear Foot

SPECIAL PROVISION

SECTION 626

FOUNDATIONS, CONDUITS, AND JUNCTION BOXES FOR
HIGHWAY SIGNING, LIGHTING, AND SIGNALS

(36-Inch Diameter Drilled Shaft)
(30-Inch Diameter Drilled Shaft – Rock Socket)

626.01 Description

The following paragraphs are added:

The work shall also consist of furnishing and constructing cast-in-place reinforced concrete drilled shafts for the open road tolling (ORT) overhead gantry and overhead guide sign support structures at the locations shown on the Plans.

626.02 General

The following are added:

Reinforcing Steel Section 503

626.022 Equipment List and Drawings

The following are added:

A. Submittals

All submittals shall be made in accordance with Subsection 105.7 of these Specifications.

1. Construction Experience Submittal

Prior to the start of shaft construction, the Contractor shall electronically submit a project reference list to the Engineer for approval verifying the successful completion by the Contractor of at least three separate foundation projects with shafts of diameters and depths similar to or larger than those shown in the Plans, and ground conditions similar to those identified in the Contract. A brief description of each listed project shall be provided along with the name and current phone number of the project owner or the owner's Contractor.

Prior to the start of shaft construction, the Contractor shall electronically submit a list identifying the on-site supervisors and drill rig operators potentially assigned to the project to the Engineer for approval. The list shall contain a brief description of each individual's experience in shaft excavation operations and placement of assembled steel reinforcing bar cages and concrete in shafts. The individual experience lists shall be limited to a single page for each supervisor or operator.

- a. On-site supervisors shall have a minimum two years experience in supervising construction of shaft foundations of similar size (diameter and depth) and scope to those shown in the Plans, and similar geotechnical conditions to those described in the boring logs and summary of geotechnical conditions. Work experience shall be direct supervisory responsibility for the on-site shaft construction operations. Project management personnel who are indirectly supervising on-site shaft construction operations are not acceptable for this experience requirement.
- b. Drill rig operators shall have a minimum of one year experience in construction of shaft foundations.

The Engineer will approve or reject the Contractor's qualifications and field personnel in accordance with Subsection 105.7 after receipt of the submission. Work shall not be started on any shaft until the Contractor's qualifications and field personnel are approved by the Engineer. The Resident may suspend the shaft construction if the Contractor substitutes unapproved personnel. The Contractor shall be fully liable for the additional costs resulting from the suspension of work, and no adjustments in Contract time resulting from the suspension of work will be allowed.

2. Shaft Installation Narrative Submittal

Drilled Shaft Installation Plan - The Contractor shall submit an installation plan for review and approval of the Engineer at least 30 days prior to the anticipated date of beginning drilled shaft work. This plan shall provide the following:

- a. Details of proposed equipment, methods, and sequence of operations in soils and rock to be used to:
 1. excavate and maintain an open shaft;
 2. perform final cleaning of the excavation and checking the cleanliness and soundness of the shaft walls and bottom bearing surface;
 3. produce, maintain, mix and reclaim slurry;
 4. place reinforcing steel;
 5. place concrete;
 6. pre-excavate, remove, and dispose of obstructions;
- b. Welding procedures and qualifications of welders and tackers as specified in AWS D1.1 for casing steel and AWS D12.1 for reinforcing steel. Test reports and installation logs as specified herein. Submit proposed installation log forms for acceptance.
- c. Methods of excavation and vibration control through overburden, soil with cobbles and boulders, and bedrock.
- d. Include details of the methods and materials used to fill or eliminate all voids between the plan shaft diameter and excavated shaft diameter. Include a disposal plan for any contaminated water or concrete expelled from the top of the shaft.
- e. Details of the proposed method(s) for ensuring drilled shaft stability during excavation and concrete placement.
- f. Method of monitoring plumbness and location of the shaft during construction.

- g. Details for the use of drilling slurry including methods to mix, circulate, de-sand, maintain and dispose of the slurry. Include a discussion of the suitability of the proposed drilling slurry in relation to the anticipated subsurface conditions.
- h. A plan for quality control of drilling slurries. In the quality control plan, include property requirements, required tests and test methods to ensure the slurry performs as intended. Submit to the Engineer the name and current phone number of the slurry manufacturer's representative who will provide technical assistance during construction.
- i. Data from the drilling slurry supplier giving the recommended physical and chemical properties of the slurry. During construction, furnish the results of quality control tests performed on the slurry promptly after the tests are completed. Submit record copies upon completion of drilled shaft construction.
- j. Method and location of slurry preparation, site distribution, reclamation, and disposal.
- k. Slurry mix composition, conditioners, additives, and methods of monitoring and testing to comply with requirements specified.
- l. Method of monitoring and continuously maintaining slurry level in drilled shafts including methods of monitoring and maintaining slurry level in excavation left overnight, or over an extended period of time.
- m. If drilling fluids other than bentonite are proposed, the submittal must include evidence that a stable excavation can be maintained and a description of the proposed slurry method. Furnish manufacturer's proposed modifications to the physical and chemical properties and method of testing specified herein for bentonite drilling fluid.
- n. Method of maintaining stability of drilled shafts in the event of sudden slurry loss or loss of slurry stabilization properties.
- o. Reinforcing steel shop drawings and details of reinforcement placement, including bracing, centering and lifting methods and the method for supporting the reinforcement on the bottom of the shaft excavation. Include details for ensuring the reinforcing cage position is maintained during construction. Include details for attaching the cross hole sonic logging test access tubes to the reinforcing cage.
- p. Evidence that the proposed materials and concrete mix design conform to all applicable Specifications.
- q. Details of concrete placement, including proposed operational procedures for pumping and/or tremie methods and methods of curing and protecting the concrete. Include details for grout placement in the cross hole sonic logging test access tubes after testing is completed and shaft has been accepted by the Engineer.
- r. Detailed procedures for temporary casing installation and removal, including casing dimensions. Calculations for design of the temporary casing due to all loads imposed upon it from earth and live loads including surcharge from traffic.
- s. The Engineer shall approve or reject the drilled shaft installation plan after receipt of all submissions. The Contractor shall provide any additional information and submit a revised plan, if requested, for review and approval.

- t. All procedural approvals given by the Engineer will be subject to trial in the field and will not relieve the Contractor of the responsibility to satisfactorily complete the work. The Contractor shall submit requests for modification of adopted procedures to the Engineer. All portions of proposed construction shall be described on shop drawings and submitted to the Engineer for approval. No work shall commence prior to receiving the written approval of the proposed methods and equipment by the Engineer. This approval shall be considered in no way as relieving the Contractor of the responsibility to satisfactorily complete the work in accordance with the Plans and Specifications.

The Engineer will evaluate the shaft installation narrative for conformance with the Plans, Specifications, and Special Provisions, within the review time specified in Subsection 105.7.

626.034 Concrete Foundations

This Subsection is replaced in its entirety with the following:

The Authority has completed a test boring program to evaluate subsurface conditions in the general vicinity of proposed foundations. The associated boring log(s), as well as foundation requirements and any foundation-specific information are provided in the geotechnical report for this Project. Foundations shall consist of cast-in-place reinforced concrete drilled shafts to the size and depths shown on the Plans. Alternative foundation designs including but not limited to steel piles, spread footings, and precast elements will not be considered.

Drilled shafts shall not be permanently cased so that the concrete may be cast directly against the surrounding soil. Temporary casings may be used prior to installation of the concrete in the presence of weak or collapsible soil conditions. If soil conditions or bedrock elevations differ materially from those described on the boring logs, the Contractor shall stop work on that foundation and contact the Resident. Drilled shafts shall be installed to the depths shown on the Plans.

36 Inch Diameter drilled shaft foundations shall be cast directly against the surrounding soil and shall be rock-socketed into bedrock to the depth shown on the Plans. In areas where rock or ledge is encountered above the proposed bottom of the foundation, the Contractor shall notify the Resident who will record the differential of the depth and will forward this information to the Engineer of Record for determination whether adjustments are to be made to the proposed depth of the rock-socket. In areas where rock or ledge is deeper than the proposed bottom of the foundation, the Contractor shall notify the Resident who will record the differential of the depth. Concrete fill and reinforcement cages shall extend to the bottom of the rock socket regardless of the differential in elevations. Reinforcement for the 36-Inch Diameter Drilled Shafts shall be comprised of traditional steel rebar elements.

A. Record Information

1. Drilled shafts shall be located and staked by the Contractor who shall maintain and be responsible for all location and elevation stakes. The Contractor shall maintain a construction method log during shaft excavation and concreting of

each drilled shaft. This record shall be available for the Engineer's inspection upon request. The log shall contain for each shaft the following information:

- a. Shaft number, date, and time of installation.
 - b. Excavation procedures and equipment.
 - c. Description and approximate top and bottom elevation of each soil or rock material encountered.
 - d. Quantity of obstructions (where encountered), type of obstruction material, and drilling rate.
 - e. Condition of the bottom of excavation.
 - f. Volume of slurry for the excavation and theoretical and actual volumes of total excavation.
 - g. Elevations of the top and bottom of the shaft showing deviations (if any) from the plans.
 - h. Level and variation of the piezometric surface and slurry level.
 - i. Diameter of the as-built shafts.
 - j. Plumbness and deviation of shaft from plan location.
 - k. Type, diameter, and depth of temporary casing used during construction as required per contract drawings.
 - l. Type, diameter, and depth of permanent casing installed as required per contract drawings.
 - m. Time, type, diameter, and length(s) of reinforcing steel cage placement.
 - n. Time, method, and duration of placement of concrete.
 - o. Time and quantity of additional water added to the concrete mix on site (if applicable).
 - p. A chart showing theoretical and actual quantity of concrete placed versus depth or elevation of top of concrete in shaft during placement.
 - q. Slurry test data.
 - r. Records of any vibration monitoring performed by the Contractor or any subcontractors.
2. Submit draft record information for each completed shaft upon completion. Submit final record information for each drilled shaft no more than three weeks after completion of the Work.
 3. Results of quality control tests performed on slurry shall be reported to the Authority/Engineer as soon as each test is completed. Submit final record information for each drilled shaft no more than three weeks after completion of the Work.

B. Shaft Construction Tolerances

The following construction tolerances apply to drilled shafts unless otherwise stated in the contract documents:

1. The drilled shaft shall be within 3 inches of plan position in the horizontal plane at the plan elevation for the top of the shaft.
2. The vertical alignment of a shaft excavation shall not vary from the plan alignment by more than 1% of plumb for the total length of shaft.
3. After all the concrete is placed, the top of the reinforcing steel cage shall be no more than 6 inches above and no more than 3 inches below plan position.

4. The top elevation of the shaft shall be within 1 inch of the plan top of shaft elevation.
5. The bottom of the shaft excavation shall be perpendicular to the axis of the shaft within 1 inch per foot of shaft diameter.
6. When the shaft steel reinforcement is to extend into the structural column or cap, all plan, vertical, and elevation tolerances shall meet the structural column or cap requirements. Drilled shaft excavations constructed in such a manner that the concrete shaft cannot be completed within the required tolerances are unacceptable. Correction methods shall be submitted by the Contractor for the Engineer's review and approval before continuing with any drilled shaft construction. Correction procedures are dependent on analysis of the effect of the degree of misalignment and improper positioning.

C. Shaft Excavation

1. General

- a. Excavate drilled shafts by non-displacement methods such as rotary drilling, augering, or other accepted methods to advance the excavation through overburden materials to the required bottom elevation. Bottom elevations of drilled shafts shown on the Contract Drawings are based on design criteria developed by the Engineer and subsurface conditions based on previous borings at the site. The bottom elevation may be lowered by the Engineer to obtain the required design capacity based on the elevation and quality of the bearing material encountered during installation of each shaft. The Engineer shall be the sole judge as to the classification of the material encountered during drilled shaft excavation.
- b. Excavation equipment shall be capable of drilling through dense soils containing cobbles and boulders and into bedrock. Avoid over excavation. Conduct operations in a manner that does not damage existing facilities. Keep excavation stable at all times.
- c. Do not allow vibration or excessive wheel loads to affect drilled shafts during construction.
- d. Protect the excavation walls with a steel cylinder casing and drilling slurry, as necessary to prevent cave-ins, settlement of the surrounding earth, water intrusion, and damage to adjacent facilities from construction operations. As a minimum, when required by the contract plans a temporary steel casing shall be provided from ground surface to at least to the top of rock. Permanent casing when required by contract plans shall be provided from ground surface to at least to the top of rock. Maintain the indicated neat lines of excavation.
- e. Excavation shall proceed under slurry during shaft excavation below the groundwater level. Excavation shall not be advanced below the bottom of casing when excavating below the groundwater level in all strata overlying bedrock. Slurry shall be added to the shaft as necessary to maintain the slurry level at least 5 feet above the local piezometric groundwater level at all times.
- f. Remove all loose material, debris and muck prior to reinforcing steel and concrete placement. Airlift and suction equipment, or other suitable methods

- as accepted by the Engineer, must be available on the jobsite at all times.
- g. Monitoring and evaluation of the shafts at each stage will be performed by the Engineer. The Contractor shall provide to the Engineer safe access and assistance as required to measure the depth to the bearing stratum to determine compliance with the specification requirements. Shaft shall not be concreted until the shaft excavation has been accepted by the Engineer.
 - h. If an obstruction is encountered, notify the Engineer immediately. Refer to Section 626.034.C.6 of this specification for pertinent information and definitions.
 - i. Drilled shafts shall be installed at the proper locations within the tolerances specified herein and on the Drawings, or as directed by the Engineer. Shaft locations shall be checked during installation and appropriate measures taken, as necessary, to maintain the correct shaft location. Verticality tests shall be taken at 15 foot intervals from existing ground surface to the bottom of the drilled shaft and as directed by the Engineer.
 - j. Drilled shaft excavations that are abandoned for any reason shall be backfilled to existing ground surface with flowable fill.
 - k. The Contractor shall use excavation techniques that are technically adequate and cost effective to meet the geologic conditions encountered at the site. Excavation for drilled shafts shall be made so that the sidewalls of the hole are stable at all times.
 - l. Drilled shafts shall be excavated to the dimensions and elevations shown or as directed. Materials removed from the shaft excavations and slurry shall be disposed of according to the applicable federal, state and local regulations and shall not be discharged into any stream, waterway, or storm water drainage system.
 - m. If approved by the Engineer, a partially excavated shaft may be left open overnight, provided that the excavation is stabilized at the bottom, sides and surface to prevent soil caving or swelling or a reduction of soil strength, and is covered at the surface to protect the public.
 - n. Should the Engineer have reason to believe that the drilled shaft excavation techniques or workmanship have been deficient, so that the integrity of any excavation is in question, work on that drilled shaft shall be stopped. Drilled shaft excavation will not be allowed to resume until the deficient excavation techniques or workmanship have been changed to the satisfaction of the Engineer.
 - o. The drilled shaft dimensions and alignment shall be verified with approved methods. Final shaft depths shall be measured with a suitable weighted tape or other approved method after final cleaning. The drilled shaft excavation may be extended if the Engineer determines that the subsurface materials encountered are not capable of providing the required bearing capacity or differ from those anticipated in the design of the drilled shafts.

2. General Shaft Casing Requirements

- a. Casings shall be steel, clean, watertight, and of ample strength to withstand handling and installation induced stresses and the pressure from both concrete, surrounding earth materials and live load surcharges. The inside diameter (I.D.) of casings shall not be less than the specified size of shaft.

Casings may be either placed in a predrilled hole or advanced through the ground by twisting, driving or vibration before being cleaned out, provided the holes remain stable at all times.

- b. Permanent casings shall be used as shown on the contract plans. In areas where temporary casing are called for, permanent casings shall be used only upon written approval by the Engineer. The casing shall be continuous between top and bottom elevations.
- c. Temporary casings when /where required shall be provided to aid shaft alignment and position, to prevent sloughing of the shaft excavation, and to prevent excessive deformation around the hole unless the Contractor demonstrates to the satisfaction of the Engineer that the casing is not required.
- d. As the temporary casing is withdrawn, the level of concrete (and drilling fluid/slurry, if used) shall be maintained with a sufficient head to prevent any water and/or other extraneous materials from entering the drilled shaft. In addition to the foregoing, the level of concrete in the temporary casing shall be maintained a minimum of 5 feet above the bottom of the casing. As the casing is withdrawn, care shall be exercised to maintain an adequate level of concrete within the casing so that fluid trapped behind the casing is displaced upward and discharged at the ground surface without contaminating or displacing the shaft concrete.

3. Steel Casings

This specification covers cylindrical steel casings of uniform cross section and diameter throughout its length in which the cylindrical casing acts as a load-carrying member.

- a. Temporary casings shall be of a grade selected by the Contractor and shall be in good condition without strength impairing defects. Temporary casings shall be the responsibility of the Contractor and shall be welded ASTM A36 AASHTO M183 or A252. The thickness shall be as required to support soil, water pressure, live load surcharge and withstand handling stress, but not less than $\frac{1}{4}$ inch, unless noted otherwise on the Drawings.
- b. Permanent casings shall conform to the requirements of ASTM A252. Permanent casings shall not have been previously used. Casings having seams of spiral-lap welded construction will not be permitted for use as permanent steel casings. The thickness shall be as required to support soil, water pressure, live load surcharge and withstand handling stress, but not less than $\frac{1}{4}$ inch, unless noted otherwise on the Drawings.

4. Rock Socket Excavation

Rock socket excavation is excavation that requires rock-specific tools and/or procedures to accomplish hole advancement, such as rock augers and core barrels. All excavation, performed below the depth where rock socket excavation is authorized shall be considered incidental to the work regardless of the density, strength, hardness, or changes in type or character of materials encountered.

5. Bottom of Shaft Excavation

Appropriate means, such as a cleanout bucket or air lift, shall be employed to clean the bottom of the drilled shaft excavations. After excavation is complete, the bottom of the shaft shall be measured and sounded with a steel rod (AW) and/or a weighted tape. A check of the bearing surface by sounding shall be made in the presence of the Engineer, who shall determine if the drilled shaft excavation is acceptable. The bearing surface shall be sounded again immediately before placing concrete. Unless otherwise stated in the plans, no more than 1 inch of loose or disturbed material will be allowed at the bottom of the excavation. No more than 2 inches of loose or disturbed material will be allowed at the bottom of the excavation for skin friction drilled shafts. The drilled shaft excavation may be extended if the Engineer determines that the subsurface materials encountered are not capable of providing the required bearing capacity or differ from those anticipated in the design of the drilled shafts. If caving occurs during any construction procedure, the construction operation shall be stopped, the Engineer shall be notified, and the shaft excavation shall be stabilized by approved methods.

Measure and record the bottom elevation of the shaft excavation in the presence of the Engineer at the following stages to determine whether soil from sides of the excavation or other sediment has collected:

- a. Immediately after excavation to final depth.
- b. Immediately after cleaning and desanding.
- c. Immediately before and immediately after placement of steel.
- d. Immediately before placement of concrete.

The Engineer shall be notified of completion of each drilled shaft excavation to permit inspection before proceeding with construction.

If caving occurs during any construction procedure, the construction operation shall be stopped, the Engineer shall be notified, and the shaft excavation shall be stabilized by approved methods.

6. Shaft Obstructions

- a. Any and all objects, materials, and structures encountered during excavation shall be removed to their full depth, unless specified otherwise, or directed otherwise by the Engineer. Obstructions are defined as impenetrable objects (not including bedrock) that cannot be removed or excavated using conventional rock or soil augers, down-hole percussion hammers, drilling buckets, casing twistors, and cause a significant decrease in the rate of excavation advancement as compared to before the obstruction was encountered or as compared to shafts in close proximity advanced using the same techniques and equipment. Those obstructions located within 5 feet (1.52 m) of the top level of the ground surface during shaft drilling at shaft locations shall be removed at the expense of the Contractor. Such obstructions may include man-made materials such as old foundations, utilities, tunnels, and natural materials such as boulders and wood.
- b. The Engineer will consider the equipment, techniques, and level of effort by the Contractor and shall be the sole judge of the significance of any reduced rate of shaft advancement and the classification of obstruction excavation.

Special procedures/tools needed to remove obstructions may include: core barrels, chisels, boulder breakers, down-hole hammers, hand excavation, temporary casing, and increasing the hole diameter. Blasting shall not be permitted unless specifically approved in writing by the Engineer. The Contractor shall specifically log the depth and rate of removal of the obstruction.

- c. All obstructions encountered during shaft drilling at shaft locations shall be measured and paid for under contract unit price per linear foot.
- d. Ensure that structures and utilities are not affected by excavation. Use appropriate means and methods to preclude undermining of adjacent structures and utilities. Excavate in a manner that does not cause movement or loss of ground. The use of slurry capable of maintaining hydrostatic pressure against excavation sides may be used for excavation.
- e. Support sides of excavation and protect existing structures and utilities in accordance with all legal regulations, and all applicable specifications, including (but not limited) to OSHA Labor 29 CFR Subpart P, Excavations, Parts 1926.650 to .652 and per Appendix A whichever is the most stringent. If pre-excavation or removal of obstructions is required below the water table, or if the Contractor proposes to excavate below the water table, Contractor shall submit proposed means and methods for review and acceptance by the Engineer, including methods of backfilling excavations below the water table with flowable fill or grout.
- f. Backfilling: For shallower excavation above the water table, backfill may consist of clean sand or gravel borrow, which may be mixed with bentonite and cement in a proportion that provides a stable material capable of supporting construction equipment and will not slough during subsequent excavation and drilling operations. Place backfill as soon as practicable after pre-excavation.
- g. To the extent practical, limit removal of curbs, and pavement during excavation. Restore to the same condition that existed prior to construction using materials that match those existing at the start of construction. Excavation Work shall be incidental to the cost of construction of drilled shaft foundation work.
- h. Drilling tools that are lost in the excavation shall not be considered obstructions and shall be promptly removed by the Contractor without compensation. All costs due to lost tool removal shall be borne by the Contractor including but not limited to, costs associated with the repair of hole degradation due to removal operations or an excessive time that the hole remains open.
- i. The rate of occurrence of obstruction encounters during the excavation and construction of drilled shafts may vary considerably from what is inferred from the boring logs due to sampling limitations of the boring(s), sampling bias due to the diameter differences between the drilled shaft and the boring(s), and spatial variability of the soil deposit.
- j. The Engineer shall be present to evaluate the occurrence of obstructions, to authorize, and to approve the designation of such. Sloping bedrock and/or higher than anticipated bedrock, as inferred from the borings, shall not be considered obstruction excavation.

10. Maintenance of a Stable Shaft Excavation

The Contractor shall demonstrate to the satisfaction of the Resident that stable conditions are being maintained. If the Resident determines that stable conditions are not being maintained, the Contractor shall immediately take action to stabilize the shaft. The Contractor shall submit a revised shaft installation narrative that addresses the problem and prevents future instability. The Contractor shall not continue with shaft construction until the damage that has already occurred is repaired in accordance with the Specifications and Special Provisions, and until receiving the Resident's approval of the revised shaft installation narrative.

11. Protection of Existing Structures and Facilities

Provide temporary covering wherever necessary to protect adjacent structures, pavements, and other facilities from spillage of excavated material, slurry, and concrete. At the completion of drilled shaft construction, restore adjacent exterior surfaces to their original conditions.

The Contractor shall control his operations to prevent damage to existing structures and utilities. Preventive measures shall include, but are not limited to, selecting construction methods and procedures that will prevent caving of the shaft excavation, monitoring and controlling the vibrations from construction activities such as the driving of casing or sheeting and drilling of the shaft. The Contractor shall be responsible for selecting and using equipment and procedures that keep deformations of adjacent structures within acceptable levels as determined by the Engineer.

D. Drilling Slurry

1. Drilling slurry shall conform to one of the following specifications. Reports of all required tests shall be furnished to the Engineer upon completion of each drilled shaft. Slurry shall be a stable suspension of powdered bentonite in potable water. Bentonite shall be pure premium grade, sodium cation based bentonite consisting mainly of montmorillonite and shall conform to the requirements of API Specification 13A. Maintain characteristics of slurry that are compatible with characteristics of the excavated soil.
 - a. Bentonite Slurry - Bentonite slurry shall be premixed thoroughly with water and adequate time, as prescribed by the manufacturer, shall be allotted for hydration prior to introduction into the shaft hole. Slurry tanks of adequate capacity are required for slurry circulation, storage, and treatment. Control tests shall be performed on the bentonite slurry by the Contractor to determine density, viscosity, sand content, fluid loss and pH. Properties of bentonite slurry in water shall meet the following range of values:

Property	Value Required	Test Method
Density (Unit Weight)*	65-80 lb/ft ³ (during drilling)	Mud Density API 13B-1 Section 1
Density (Unit Weight)*	65-70 lb/ft ³ (prior to concrete placement)	Mud Density API 13B-1 Section 1
Viscosity	40-50 sec/qt	Marsh Funnel and Cup API 13B5-1 Section 2.2
pH	7-11	Glass Electrode, pH Meter, or pH Paper
Sand Content	4.0% by volume maximum	Sand Content API 13B-1 Section 5
Fluid Loss	25cc Maximum in 30 min.	Filter Press

*To be increased by 2lb/ft³ in salt water or brackish water.

Tests to determine density, viscosity and pH shall be performed during shaft excavation to establish a consistent working pattern. Four sets of tests shall be made during the first 8 hours of slurry use. When the results show consistent behavior, one set of testing shall be made every 4 hours of slurry use thereafter. Test fluid loss every two days.

1. Yield: 90 barrel per ton, minimum.
 2. Dwell time in mixer: As required to achieve proper blending of slurry for the type of mixer used: 10 minutes maximum.
 3. Storage time to allow hydration: Bentonite slurry shall not be used for a period of at least 8 hours after it is initially mixed except where permitted by the Authority.
- b. Polymer Slurry - Natural or synthetic slurry shall have specific properties at the time of mixing and of concreting that are in conformance with the written recommendations of the manufacturer and the Contractor's Drilled Shaft Installation Plan as accepted by the Engineer. The Contractor shall perform the required tests at the specified frequency and shall provide slurry that complies with the maximum and/or minimum property requirements for the subsurface conditions at the site and with the construction methods that are used. Whatever product is used, the sand content at the base of the shaft excavation shall not exceed 1% when measured by the API sand content test, immediately prior to concreting.
- c. Contractor shall anticipate encountering brackish groundwater, ash, and cinder fill, leakage from storm and sanitary sewers, and other agents that may be deleterious to the slurry. Contractor is responsible for and shall modify the slurry mix as required so as to maintain a stable suspension at all times.

2. Control Testing of Bentonite Slurry.

Perform control testing of bentonite slurry in accordance with American Petroleum Institute (API) Specification 13B, using suitable apparatus, to determine the following parameters:

- a. Density, by mud density balance.
- b. Viscosity, by Marsh Cone Method.
- c. Fluid loss, by filter press.
- d. pH.
- e. Sand-content.
- f. Fresh Bentonite Slurry: Measure density, pH, fluid loss and Marsh Cone viscosity of every new supply of bentonite slurry. Tests shall be made on freshly mixed as well as fully hydrated slurry as a check on the quality of slurry being formed. Density measuring device shall be calibrated to an accuracy of ± 0.05 pcf.
- g. Bentonite Slurry Inside Shaft Excavation: Perform tests specified below to verify that properties of slurry inside the excavation are within specified limits. Measure density, Marsh Cone viscosity, and fluid loss of bentonite slurry at the point of supply. Measure pH from samples collected from inside the top and bottom of shaft. Frequency of testing is every 2 hours of work on each shaft, unless specified otherwise. Field conditions may require more frequent testing to ensure acceptable slurry properties.
 - i. Density.
 - ii. Viscosity.
 - iii. Fluid Loss: Every 2 days.
 - iv. pH: Every 2 hours and when viscosity is above specified limits.
- h. Bentonite Slurry in Shaft Prior Placing Concrete: Immediately prior to placing concrete in any shaft excavation, take a sample of the slurry within 12 inches of the bottom of shaft, and test it for density, viscosity and sand content. Modify or replace the slurry in the excavation if the test parameters of the sample exceed limits specified. Do not place any concrete in the excavation until the density of the slurry in the excavation is correct and the sand content has been found to be 4 percent by volume or lower. Additional tests shall be performed at this time if requested by the Authority or Engineer.
- i. Measure the level of slurry in each open shaft excavation at the beginning and end of every shift or as directed by the Engineer.
- j. Results of quality control tests performed on the slurry shall be reported to the Engineer as soon as each test is completed.

E. Steel Reinforcement Configuration and Placement

1. Where it is not practical to deliver the assembled reinforcing steel to the jobsite as a complete unit ready for installation, make splices on site prior to lowering the assembly into the hole. Provide splices only as shown on the Contract Drawings or on accepted Shop Drawings.
2. Prior to installation of reinforcing steel, inspect and clean steel of materials that prevent effective bonding.
3. Place reinforcing steel in excavation shaft immediately after cleaning and sounding the bottom as specified herein. Reinforcing steel shall be equipped with non-corrosive non-metallic centralizers to provide specified minimum concrete cover. Concrete or plastic rollers less than 3 inches wide shall not be allowed. Centralizers shall be spaced at intervals necessary to maintain specified cover, but in no case shall the

- spacing be greater than 10 feet. The spacing of the spirals and/or ties may be adjusted slightly to accommodate the rotation of the centering devices. Cylindrical concrete feet, or approved alternate bottom supports, shall be provided to ensure that the bottom of the cage is maintained 3 inches above the base. Dropping or forcing of steel into the shaft shall not be permitted. If the reinforcing steel does not properly or smoothly enter the excavation, it shall be retrieved and the excavation adjusted and properly cleaned as specified until the reinforcing fits smoothly. Repair or replace damaged reinforcing.
4. After installation of reinforcing steel and immediately prior to concrete placement, the bottom of the excavation shall be measured and inspected as specified herein to determine if sediment has accumulated on the shaft bottom. If sediment is found to have accumulated on the shaft bottom, clean the bottom of the excavation with an air-lift or other equipment acceptable to the Engineer, which is capable of removing the sediment.
 5. The clear spacing between bars of the steel reinforcement cage shall be at least 5 times the size of the maximum coarse aggregate size of concrete. Hooks at the top of the steel reinforcement cage shall not be bent outward where temporary casing is used. Similarly, interior hooks must be designed to permit adequate clearance for a concrete tremie pipe.
 6. The assembled steel reinforcement cage outside diameter must be at least 6 inches smaller than the drilled hole diameter. This clear space is necessary both to permit free flow of concrete up the annular space between the cage and the hole perimeter and to provide adequate concrete cover over the steel reinforcement cage.
 7. The steel reinforcement cage, consisting of longitudinal bars, spirals and/or ties, cage stiffener bars, spacers, centralizers, and other necessary appurtenances, shall be completely assembled and placed as a unit immediately after the shaft excavation is inspected and accepted. The steel reinforcement cage shall be supported by positive methods to prevent its displacement during concrete placement.
 8. Welding of the reinforcing bars shall not be permitted without the written approval of the Engineer.

F. Placing Concrete

1. Concrete Cover Over Reinforcing Bars

Reinforcing bars shall be placed as shown in the Plans with concrete cover as noted in the Plans.

2. Concrete Class for Shaft Concrete

Concrete for drilled shafts shall be Class AAA in accordance with Section 502, Structural Concrete, with the following exceptions:

- a. Minimum cement factor of 7-1/2 bags per cubic yard.
- b. Sand proportions high enough for proper flow and placement of the tremie concrete.
- c. Rounded gravel aggregate or crushed stone with maximum size of 3/8 inch.
- d. Slump: 7 to 9 inches.
- e. Fly ash: 10 percent minimum.
- f. Air content: 4 percent plus or minus 1-1/2 percent, when tested at the point of

discharge from the truck mixer.

Precast foundations will not be permitted.

3. Concrete Placement Requirements

- a. Place concrete immediately after inspection by the Engineer of the completed excavation and placement of reinforcement.
- b. Drilled shaft concrete shall be carefully placed so as to form a consolidated monolith composed of a cylindrical shaft to at least 1 foot above cutoff to ensure removal of slurry contaminated concrete. Concrete shall be placed through a tremie.
- c. When temporary casing is used to support the excavation:
 - i. Withdraw the casing while concrete is still fluid, before initial set.
 - ii. Withdraw the temporary steel casing used to support the excavation walls as the drilled shaft concrete is being placed unless otherwise indicated, or unless the Engineer requires that the casing is to be left in place. Withdraw casing when concrete pressure at casing seal exceeds water and soil pressure at that level. Tremie concrete shall be a minimum of 5 feet above the bottom of the steel casing at all times as the casing is being withdrawn. Remove the steel casing in a manner that prevents water and earth from entering the casing at the bottom. Do not damage or displace reinforcing cage when withdrawing casing. No temporary steel casing shall be withdrawn prior to commencing placement of tremie concrete within the cased zone. Ensure that fluid trapped behind the casing is displaced upward and discharged at the ground surface without contaminating or displacing the drilled shaft concrete.
- d. Cure and finish the top of the shaft to comply with the Drawings.
- e. Shafts that are not concreted within 8 hours after completion of drilling shall have the slurry re-circulated and re-cleaned using an airlift and a de-sanding unit to maintain slurry uniformity throughout the depth of the shaft prior to placing concrete.

4. Additional Requirements For Slurry Displacement Method

- a. Maintain the slurry level at least five feet above the groundwater level and a sufficient distance above unstable zones to prevent caving or sloughing of earth.
- b. Test the slurry as specified herein to verify satisfactory characteristics before concrete placement is started. Place concrete within 2 hours of completion of reinforcing steel placement. Pump the displaced slurry to a holding tank. Do not spill slurry on the site or use holding pits. Dispose of slurry in a legal manner when no longer needed.
- c. Place concrete by accepted tremie method, using at least eight inch inside diameter tremie pipe.
- d. Use a tremie pipe made with watertight joints.
- e. Tremies used to place cement concrete shall consist of a tube of sufficient

length, weight, and diameter to discharge cement concrete at the shaft base elevation.

- f. The tremie shall not contain aluminum parts that will have contact with the concrete.
- g. The tremie inside diameter shall be at least 6 times the maximum size of aggregate used in the cement concrete mix but shall not be less than 8 inches for tremie pipe or 4 inches for pump hose.
- h. The inside and outside surfaces of the tremie shall be clean and smooth to permit both flow of cement concrete and unimpeded withdrawal during concreting.
- i. The wall thickness of the tremie shall be adequate to prevent crimping or shear bends that restrict cement concrete placement.
- j. An alternate delivery system that can be used in case of failure of the primary delivery system shall be provided.
- k. Place an inflatable spherical separator in the tremie pipe immediately prior to introduction of concrete, to separate the concrete from the slurry. Keep the bottom of the tremie pipe within 8 inches of the shaft bottom until the separator floats to the surface of the excavation.
- l. The discharge end of the tremie shall be constructed to permit the free radial flow of concrete during placement operations.
- m. If concrete is placed under water or slurry, all displaced water or slurry shall be disposed of in an approved manner. When groundwater, the drilling water or slurry in the shaft excavation is to be removed by pumping during concrete placement, a standby pump shall be kept available on-site.
- n. Keep the tremie pipe embedded in the concrete at least 10 feet throughout the concrete placement to maintain a seal against slurry mixing into the concrete. No horizontal movement of the tremie pipe will be permitted.
- o. Remove and dispose of the first portion of concrete, contaminated with slurry that reaches the top of the shaft.

5. Sequencing and Scheduling

Drilled shaft excavation and cement concrete placement shall be scheduled so that each drilled shaft is cast immediately after drilling operations are complete. After the first drilled shaft on a project has been accepted, no significant change in construction methods, equipment, or materials used shall be made in the construction of subsequent shafts, unless approved by the Engineer. Construction of subsequent shafts shall not proceed until the first drilled shaft has been approved by the Engineer. Drilling may commence on a subsequent shaft at an approved location provided that the cement concrete placement operation on the previous drilled shaft is in progress and there are sufficient workers present to complete all required operations.

- a. For a minimum period of 24 hours after completion of the cement concrete placement operation in a newly constructed shaft, including withdrawal of casing if applicable, none of the following operations shall be permitted within 15 feet of the newly constructed shaft:

1. Excavation for adjacent shafts;
2. Construction of footings;
3. Application of equipment loads;
4. Introduction of vibrations with a peak particle velocity of greater than 1/4 inch per second.

G. Cross-hole Sonic Testing (CSL)

Cross-hole sonic logging (CSL) is a down-hole ultrasonic test method used to evaluate the condition of the concrete within drilled shafts. The test shall meet ASTM. D-6760 requirements as modified herein. This method involves using a piezoelectric transducer (emitter), to generate a signal that propagates as a sound wave (sonic) within the concrete, and another transducer (receiver) is used to detect the signal. Both transducers are placed into a vertical steel pipe filled with water that acts as a coupling medium between the transducer and the tube. These pipes are attached to the reinforcement cage. The transducers are lowered to the bottom of their respective pipes and placed in the same horizontal plane. The emitter transducer generates a sonic pulse that is detected by the receiver in the opposite pipe. While the pulses are generated, the two transducers are simultaneously raised within the pipes until they reach the top of the drilled shaft. This process is repeated for each possible pipe combination. The existence of a flaw or defect (void, soil inclusion, or necking within the shaft) will slow down the signal. The signal arrival times are plotted with depth to generate a log for the particular pipe combination. In addition, the energy of each signal (integration of the amplitude with time) is also plotted with depth. Lower energy or longer arrival times would indicate the occurrence and location of the defects.

1. Requirements.

Provisions for sonic testing shall be made for all shafts. The testing subcontractor and test method to be used for sonic testing shall be approved by the Engineer. A record of experience of the testing subcontractor shall be submitted to the Engineer along with written description of the testing procedures, operation manuals for the testing equipment, and samples of previous test results indicating both sound and defective shaft.

2. Installation of Pipes.

The Contractor shall furnish and install a minimum of four 1.5 to 2 inch internal diameter steel pipes to provide access for sonic testing in each drilled shaft. The pipes shall be installed such that all internal joints are flush. If the number and placement of the pipes are not called out in the construction drawings, then the following guidelines shall be used:

Shaft Diameter \leq 5 feet	4 Pipes Minimum
5 feet < Shaft Diameter \leq 8 feet	6 Pipes Minimum
Shaft Diameter > 8 feet	8 Pipes Minimum

The steel pipes shall be connected so that the transducers can pass through unobstructed. The tubes shall be clean from any corrosion or dirt to ensure a good bond between the tube and concrete. The pipes shall be watertight (including at

joints) and capped at the bottom and the top. The top cap must be removable (i.e. threaded) for access of the transducers during testing.

The pipes shall be attached to the interior of the reinforcement cage or as specified in the contract documents. However, if the clear spacing between longitudinal bars is less than 5 inches, the pipes shall be offset from the rebar cage by 3 inches toward the center of the shaft. The pipes shall be located in a symmetric pattern depending on the size of the shaft and the number of pipes. Tie wire or spacers shall be used to attach the pipes to the reinforcement cage so that they remain as vertical and parallel as possible during cage installation. The pipes shall extend from 6 inches above the bottom of the shaft (accounting for to 3 feet above the top of the shaft, or ground surface, whichever is higher). The pipes shall not be placed on the bottom of the shaft.

The pipes shall be full of clean water prior to cement concrete placement. The caps must be sealed to prevent debris from entering the pipes after the water is placed. The pipes must be handled with care during installation and capping (i.e. no twisting or impacting). After completion of CSL testing and upon approval of the Drilled Shaft by the Engineer, the water shall be removed from the pipes to be completely filled with a cement or sand-cement grout.

3. Sonic Logging Equipment.

The Sonic Logging equipment furnished by the Contractor shall consist of the following components:

- a. Ultrasonic emitter and receiver probes capable of producing records with good signal amplitude and energy through concrete.
- b. A measurement wheel or other suitable linear measuring device to record the depth of the transducers.
- c. A microprocessor based system, with data filtering amplification and synchronized triggering of records with pulses that is capable of permanent recording of data, display of individual records, and printing of logs. The Contractor shall also furnish all necessary supplies, support equipment, power, and provide reasonable access to the shaft top for performance of the sonic logging.

4. Sonic Logging Test Procedure

Completed drilled shafts shall be tested between 1 and 7 days after placing of cement concrete. Information on the drilled shafts to be provided to the CSL consultant shall include: Shaft bottom and top elevations, pipe lengths and positions, and construction dates including cement concrete placement. Sonic Logging shall be performed between all possible tube combinations. Tests shall be performed in the same horizontal plane in all pairs of pipes directly across from each other. Tests involving different horizontal planes would be conducted if requested by the Engineer or when necessary to further evaluate defects. The probes shall be raised simultaneously from the bottom of the pipes by winch ensuring that all slack is taken out of the cables before the analyzer is switched on. The speed of ascent should be less than 1 foot per second. A depth wheel or similar measuring device shall be used

to provide accurate depth measurements. Measurements shall be taken at 0.2 feet intervals or as otherwise directed by the Engineer.

5. Results of Testing.

The Contractor shall provide a CSL Report signed by a Professional Engineer providing the results and recommendations for acceptance or correction of each shaft tested. The report shall include the following:

- a. The cross-hole sonic logs with potential defects indicated. Records of the initial pulse arrival time and energy/amplitude vs. depth for each pipe combination. Related interpretation and discussion of the results.
- b. Defects identified by longer arrival times or lower energy signals shall be promptly reported to the Engineer. Any further tests required by the Engineer to evaluate the extent of the defects shall be duly carried out.

6. Acceptance.

Any indicated drilled shaft defects shall require further integrity testing. The Engineer may require other non-destructive tests upon evaluation of the data. These tests may include cross-hole tomography, Single-hole Sonic Logging, Pulse Echo Method, or others.

If the additional tests and records are inconclusive, the Engineer may require core holes of the defective shaft, at the expense of the Contractor. If the cores show defects in the shaft, these defects shall be repaired at the Contractor's expense by methods acceptable to the Authority.

H. Defective Drilled Shafts

Defective drilled shafts are defined as exhibiting flaws that result in inadequate performance (deflections criteria) or unsafe performance (capacities criteria) under the shaft design loads, as determined by the Engineer, based on the shaft construction records, or NDE.

The Contractor shall submit a plan for remedial action to the Engineer for acceptance. Modifications to the structural integrity and/or load transfer mechanism caused by the remedial action shall require that calculations and working drawings stamped by a Professional Engineer registered in the Commonwealth of Massachusetts for all elements affected, be provided. All labor and materials necessary to complete the remedial work shall be furnished without cost to the Authority.

626.04 Method of Measurement

This Section is replaced in its entirety with the following:

Foundation Pay Items 626.3321, and 626.3322 will be measured by the linear foot based on the proposed elevations for each element as shown on the Plans.

For Pay Item 626.3321, 36-Inch Diameter Drilled Shaft, the limits of measurement shall be from the top of bedrock to the top elevation of the drilled shaft as shown on the Plans.

For Pay Item 626.3322, 30-Inch Diameter Drilled Shaft – Rock Socket, the limits of measurement shall be from the bottom of the rock socket to the top of bedrock. The theoretical length per rock socket is shown on the Plans. In the event that a deeper rock socket is required as determined by the Engineer of Record, the limit of measurement shall include the full constructed length of the rock socket.

626.05 Basis of Payment

This Section is replaced in its entirety with the following:

The accepted quantity of 36-Inch Diameter Drilled Shaft will be paid for at the Contract unit price per linear foot of shaft drilled and installed. This payment shall include: drilling/excavation of the soil, dewatering, installation and removal of temporary casings (if necessary), concrete, steel reinforcing, and all incidentals necessary to complete the work.

The accepted quantity of 30-Inch Diameter Drilled Shaft – Rock Socket will be paid for at the Contract unit price per linear foot of shaft rock socketed. This payment shall include: drilling/excavation of the rock, dewatering, concrete, steel reinforcing, and all incidentals necessary to complete the work.

Drilled shaft reinforcement which extends above the top of the drilled shaft shall be incidental to the drilled shaft pay item.

Dewatering shall be incidental to the respective drilled shaft pay items.

Payment will be made under:

<u>Pay Item</u>		<u>Pay Unit</u>
626.3321	36-inch Diameter Drilled Shaft	Linear Foot
626.3322	30-inch Diameter Drilled Shaft – Rock Socket	Linear Foot

SPECIAL PROVISIONSECTION 626FOUNDATIONS, CONDUIT, AND JUNCTION BOXES
FOR HIGHWAY SIGNING, LIGHTING AND SIGNALS

(Quazite Junction Box (36x24))
(Barrier Junction Box)

626.02 General

The following paragraph is added:

Junction boxes for the electrical and communication conduit associated with the toll equipment and intelligent transportations systems shall be polymer concrete as manufactured by QUAZITE® a division of Hubbell Power Systems. The boxes shall be 36" x 24" and 24" deep. The words ELECTRICAL or COMMUNICATION or LIGHTING shall be stamped on the cover as noted in the Plans or directed by the Resident. The boxes shall have an 22,000 lb. load rating. All existing QUAZITE® Junction Boxes shall be abandoned as directed by the Resident Engineer.

All existing Precast Junction Boxes shall be removed and salvaged to the MTA as directed by the Resident Engineer. New boxes shall have the word LIGHTING stamped on the cover.

Barrier Junction boxes for the electrical associated with highway lighting to be installed in the barrier shall be 18" x 12" x 9" and shall be made from stainless steel.

626.04 Method of Measurement

The following sentence is added:

Quazite junction box shall be measured by each unit in place and accepted existing or new. Barrier junction box shall be measured by each unit in place and accepted.

626.05 Basis of Payment

The words, "polymer concrete" shall be added after the words, "precast concrete" in the second sentence of the second paragraph.

Payment will be made under:

<u>Pay Item</u>		<u>Pay Unit</u>
626.12	Quazite Junction Box (36 x 24)	Each
626.111	Barrier Junction Box	Each

SPECIAL PROVISION

SECTION 626

FOUNDATIONS, CONDUIT, AND JUNCTION BOXES
FOR HIGHWAY SIGNING, LIGHTING AND SIGNALS

(Light Standard Foundation)

General

The following paragraph is added:

Light standard foundations shall be pre-cast concrete as manufactured and shall be meet the requirements of the light standard manufacturer for bolt circle diameter, anchor bolt thickness, anchor bolt projection, depth, and width.

The light standard foundation shall accommodate break away devices and shall meet all MTA and Maine DOT requirements.

Method of Measurement

The light standard foundation shall be measured by each unit in place and accepted existing or new.

Basis of Payment

The light standard foundation shall be paid for by each unit in place including all excavation, backfill, equipment, material and labor to complete the installation.

Payment will be made under:

<u>Pay Item</u>	<u>Pay Unit</u>
626.341 Light Standard Foundation	Each

SPECIAL PROVISION

SECTION 627

PAVEMENT MARKINGS

(Pavement Marking Tape)
(Pavement Marking Tape – White Dotted Lane Line, 6-inch Width)

627.01 Description

The following sentence is added:

This work shall consist of furnishing and placing reflective pavement marking tape in conformity with the Plans, as specified herein and as directed by the Resident.

The pavement marking tape shall be installed at all locations.

627.02 Materials

The following sentence is added:

For the Broken White Line (BWL), Pavement Marking Tape shall be 3M Stamark™ High Performance Tape Series 380AW – High Performance pavement marking tape, color- white, six (6) inch width, as manufactured by 3M of St. Paul, Minnesota.

For the White Dotted Lane Line (WDLL), Pavement Marking Tape shall be 3M Stamark™ High Performance Tape Series 380I ES – High Performance pavement marking tape, color- white, six (6) inch wide and twelve (12) inch wide, as manufactured by 3M of St. Paul, Minnesota.

3M Traffic Safety Systems Division
Mr. Michael D. Allen
Tel: (401) 368-0438
Email: mdallen@mmm.com

627.04 General

The following paragraphs are added:

The tape shall be used as a supplemental broken white lane line. The tape shall be installed between the painted Broken White Line (BWL) spaced eighty (80) foot center to center as shown on the Plans. The length of the tape shall be three (3) feet.

The tape shall also be used to mark a White Dotted Lane Line (WDLL) and shall be installed on parallel deceleration and acceleration lanes at locations as noted in the Plans. On deceleration lanes, the tape shall be installed from the beginning of the full width deceleration lane and shall extend to the theoretical gore markings. On acceleration lanes, the WDLL shall extend from the theoretical gore markings to a point one-half of the total length of the acceleration lane (including the lane taper length). Layout data is noted on the Plans. White Dotted Lane Line tape

shall be three (3) foot in length and shall be spaced nine (9) feet apart. Spacing from the Solid White Line (SWL) or the Theoretical Gore Markings shall be nine (9) feet.

627.05 Preparation of Surface

The following paragraph is added:

The Contractor shall mill a groove in the pavement for each tape length to be placed (“in-and-out” pattern). Continuous grooving for installation of the tape shall not be allowed. The groove length shall be the required tape length plus 12 inches on both ends. Tape length spacing shall be as shown on the plans. The groove width for inlaid tape pavement marking shall be the pavement marking width plus 1 inch, with a tolerance of $\pm \frac{1}{4}$ inch. The groove shall have a uniform depth of 150 Mils (± 20 Mils). Groove position shall be a minimum of 2 inches from the edge of the pavement marking to the longitudinal pavement joint. The bottom of the groove shall have a smooth, flat finished surface. The use of gang stacked Diamond cutting blades is required for asphalt pavement surfaces. The spacers between blade cuts shall be such that there will be less than a 10 mil rise in the finished groove between the blades.

Grooves shall be clean, dry and free of laitance, oil, dirt, grease, paint or other foreign contaminants. The Contractor shall prevent traffic from traversing the grooves, and re-clean grooves, as necessary, prior to application of the primer and pavement marking tape. Depth plates shall be provided by the Contractor to assure that desired groove depth is achieved.

Reference is made to 3M Information Folder 5.18 Grooving Applications, May 2011, “Application Guidelines for Pavement Marking in Grooved Pavement Surfaces.”

627.09 Method of Measurements

The following paragraph is added:

The quantity of Pavement Marking Tape measured for payment will be the linear feet of tape in place and accepted. The measurement will not include the gaps. The groove shall be measured by the square foot.

627.10 Basis of Payment

The following paragraphs are added:

The accepted quantity of pavement marking tape will be paid for at the Contract unit price per linear foot which price shall include all material, equipment, labor and incidentals necessary to complete the work. Pavement grooving shall be paid per square foot.

Payment will be made under:

<u>Pay Item</u>		<u>Pay Unit</u>
627.4072	Pref Pave Mark Tape Line, Groove Install	Square Foot
627.94	Pavement Marking Tape	Linear Foot
627.941	Pavement Marking Tape – White Dotted Lane Line, 6-inch Width	Linear Foot

SPECIAL PROVISION

SECTION 627

PAVEMENT MARKINGS

(Temporary 6 Inch Pavement Marking Tape)
(Temporary 6 Inch Black Pavement Marking Tape)

627.01 Description

The following sentence is added:

This work shall also consist of furnishing, placing, maintaining and removing temporary pavement marking tape at locations shown on the Plans or as directed by the Resident.

This work shall also consist of furnishing, placing, maintaining and removing temporary black pavement marking tape at locations shown on the Plans or as directed by the Resident. Temporary 6 Inch Black Pavement Marking Tape shall be used to cover conflicting existing pavement marking paint.

627.02 Materials

The following paragraph is added:

Temporary pavement marking tape shall be Stamark Wet Reflective Removable Pavement Marking Tape Series 710 as manufactured by 3M of St. Paul, Minnesota or an approved equal.

Temporary pavement marking tape shall be Stamark Removable Black Line Mask Tape Series 715 as manufactured by 3M of St. Paul, Minnesota or an approved equal.

627.04 General

The following paragraphs are added:

Work under this item shall be in accordance with the manufacturer's recommendations. A factory representative from 3M shall be present for the first application of all temporary pavement marking tape to insure proper application and product performance.

The pavement markings shall be applied mechanically to clean dry pavement as recommended by the manufacturer and approved by the Resident.

Temporary pavement markings shall consist of applying six inch solid white, six inch broken white, and six inch yellow reflectorized pavement marking tape for traffic maintenance during construction as shown on the Plans or as directed by the Resident.

Temporary pavement marking tape that loses reflectivity, becomes broken, dislodged or missing during the life of the Contract shall be replaced by the Contractor at no additional cost to

the Authority.

627.06 Application

The following paragraphs are added:

For application of the tape, when the pavement temperature is below 50°F, heat shall be applied to the pavement surface, if deemed necessary by the factory representative or as directed by the Resident, at no additional cost to the Authority. Proper primer for the temperatures shall be used as directed by the manufacture.

The pavement mark tape shall be rolled over with a vehicle once application is complete and then scored every 20 feet when placed in long runs to prevent full length unraveling.

627.08 Removing Lines and Markings

The following sentence is added:

Removal of temporary pavement marking tape shall be accomplished without the use of heat, solvents, grinding or sandblasting and in such a manner that no damage to the pavement results.

627.09 Method of Measurement

The following paragraph is added:

Temporary Pavement Markings - Tape will be measured for payment by the linear foot. The measurement of broken lines will not include the gaps.

627.10 Basis of Payment

The following paragraphs are added:

Payment for the Temporary Pavement Markings - Tape will be made at the Contract bid price per linear foot, which price shall include furnishing, installing, maintaining and removing the temporary tape and all materials, labor, equipment and incidentals necessary to accomplish the work. Replacement of Temporary Pavement Markings - Tape, as described above, will be incidental and no separate payment will be made.

Payment for the Temporary 6 Inch Black Pavement Marking Tape will be made at the Contract bid price per linear foot installed, which price shall include furnishing, installing, maintaining and removing the temporary tape and all materials, labor, equipment and incidentals necessary to accomplish the work. Replacement of 6 Inch Black Temporary Pavement Marking Tape, as described above, will be incidental and no separate payment will be made.

Payment will be made under:

Pay Item

Pay Unit

627.73	Temporary 6 Inch Pavement Marking Tape	Linear Foot
627.731	Temporary 6 Inch Black Pavement Marking Tape	Linear Foot

SPECIAL PROVISION

SECTION 627

PAVEMENT MARKINGS

(Temporary Raised Pavement Markers)

627.01 Description

The following sentence is added:

This work shall consist of furnishing, placing and removing temporary raised pavement markers at locations as shown on the Plans or as directed by the Resident.

627.02 Materials

The second paragraph is deleted and replaced with the following:

The temporary raised pavement markers shall be white or yellow one way markers (Type Tom W-1, Y-1, Grade WZ) as distributed by Davidson Plastics Co. (DAPCO), Kent, WA, or an approved equal. Colors shall conform to 2009 MUTCD requirements.

627.04 General

The following sentences are added:

Temporary raised pavement markers shall be used to delineate travel lanes (BWLL) after placement of the surface course (HMA 12.5 mm).

Temporary raised pavement marker that lose reflectivity, becomes broken, dislodged or missing during the life of the Contract shall be replaced by the Contractor at no additional cost to the Authority.

The spacing and number of temporary pavement markers installed as edge lines shall be the same as shown for the BWLL on the Plans for Temporary Pavement Marking.

627.09 Method of Measurement

The following sentence is added:

Temporary Raised Pavement Markers will be measured by each unit, complete in place, maintained and accepted.

627.10 Basis of Payment

The following paragraphs are added:

The accepted quantity of Temporary Raised Pavement Markers white and/or yellow will be paid for at the Contract price each. This price shall include all labor and materials to furnish, install, maintain, and remove the markers.

Payment will be made under:

<u>Pay Item</u>		<u>Pay Unit</u>
627.812	Temporary Raised Pavement Markers	Each

SPECIAL PROVISION

SECTION 627

PAVEMENT MARKINGS

(Temporary Painted Pavement Markings)

627.01 Description

The following paragraphs are added:

This work shall consist of furnishing and placing permanent pavement marking paint and temporary painted pavement markings at locations shown on the Plans or as approved by the Resident.

Lines on the turnpike shall be six inches wide. Lines on local roads shall be four inches wide.

Temporary raised pavement markers will not be allowed as a substitute for temporary painted pavement marking lines unless approved by the Resident for use as a transition between the existing pavement markings and the temporary painted pavement marking lines. Temporary raised pavement markings may be used as a substitute for temporary painted pavement markings when the markings are immediately adjacent to a concrete barrier or guardrail such that the markings will not be subject to traffic. The temporary raised pavement markers will be measured for payment as temporary painted pavement markings when their use has been approved by the Resident.

627.02 Materials

This Subsection is deleted in its entirety and replaced with the following:

Pavement marking paint shall be 100 percent acrylic, low VOC, fast drying, white and yellow waterborne traffic paint.

The paint shall be formulated and processed specifically for service as a binder for beads, in such a manner as to produce maximum adhesion, refraction, and reflection. Any capillary action of the paint shall not be such as to cause complete coverage of the beads. The binder shall be 100 percent acrylic, as determined by infrared analysis according to ASTM D2621. VOC levels shall comply with ASTM D3960. Lead percentage shall comply with ASTM D3335. The paint shall be rated as non-combustible.

627.04 General

The third paragraph is deleted and replaced with the following:

Broken lines shall consist of alternate 10 foot painted line segments and 30 foot gaps.

Dotted white lines (DWL) shall consist of alternate three foot painted line segments and

nine foot gaps.

627.09 Method of Measurement

Painted pavement marking lines will be measured by the linear foot.

The second and third sentences in the second paragraph are deleted and replaced with the following:

The measurement of broken white lines, both permanent and temporary, will include the gaps when painted. Temporary Painted Pavement Marking lines will be measured for payment by the linear foot.

Removal of the Temporary Painted Pavement Marking lines will be measured for payment as Removing Existing Pavement Markings.

627.10 Basis of Payment

The following paragraphs are added:

The accepted quantity of Painted Pavement Marking lines will be paid at the Contract price per linear foot. This price shall include all labor and materials to furnish, install and maintain the paint markings.

Payment will be made under:

<u>Pay Item</u>	<u>Pay Unit</u>
627.681 Temporary 6 Inch Painted Pavement Marking Line – Yellow or White	Linear Foot

SPECIAL PROVISION

SECTION 627

PAVEMENT MARKINGS

(Pavement Marking Symbol)

627.01 Description

The following paragraphs are added:

This work shall consist of furnishing and placing permanent pavement marking symbols pavement markings at locations shown on the Plans or as approved by the Resident.

627.02 Materials

The following sentence is added:

For the Symbols, Pavement Marking Symbols shall be 3M Stamark™ High Performance or approved equal, as manufactured by 3M of St. Paul, Minnesota.

3M Traffic Safety Systems Division
Mr. Michael D. Allen
Tel: (401) 368-0438
Email: mdallen@mmm.com

627.04 General

The following paragraphs are added:

The symbols shall be added to the toll plaza approach as shown on the plans.

627.05 Preparation of Surface

The following paragraph is added:

The surface to which the symbol shall be applied shall be clean, dry and free of laitance, oil, dirt, grease, paint or other foreign contaminants. The Contractor shall prevent traffic from traversing on the symbol area, and re-clean grooves, as necessary, prior to application of the primer and pavement marking.

627.09 Method of Measurements

The following paragraph is added:

The quantity of Pavement Symbol measured for payment will be Each installed in place and accepted.

627.10 Basis of Payment

The following paragraphs are added:

The accepted quantity of pavement marking symbols will be paid for at the Contract unit price per Each which price shall include all material, equipment, labor and incidentals necessary to complete the work.

Payment will be made under:

<u>Pay Item</u>		<u>Pay Unit</u>
627.9011	Pavement Marking Symbol	Each

SPECIAL PROVISION

SECTION 631

EQUIPMENT RENTAL

(Air Compressor Including Operator)
(Air Tool Including Operator)
(Jackhammer Including Operator)
(All Purpose Excavator Including Operator)
(Truck-Small Including Operator)
(Chain Saw Rental Including Operator)
(Culvert Cleaner Including Operator)
(Foreperson)
(Bucket Truck)
(Scissor Lift)
(Electrician)
(Electrician's Apprentice)

631.02 General

The following sentences are added:

Jackhammer - To be included under category of air tool.

Bucket truck - Approved one man, able to reach 30 feet high bucket truck with 10 feet lateral extension.

Scissor Lift - Hydraulic scissors lift with a minimum capacity of three workers.

Electrician - Licensed by State of Maine.

Electrician's Apprentice - Enrolled in an accredited program.

631.08 Basis of Payment

The following paragraphs are added:

Such related costs such as use of hand tools, meal and room expenses, benefits, insurance, retirement, travel time, overtime, overhead and profit will not be measured separately for payment, but shall be incidental to the unit price for the bid item.

Note: For extra materials required for miscellaneous work the General Contractor shall be allowed 15 percent overhead and profit on the cost of materials and rental equipment (not covered by miscellaneous unit items). Rates for Subcontractor owned equipment required to perform miscellaneous work, not otherwise provided for in the Contract, shall be negotiated.

The General Contractor will be allowed 10 percent overhead and profit on the subcontractor's cost of materials, and subcontractors rented equipment (not covered by

miscellaneous unit items). The General Contractor shall include his markup on the Subcontractor's labor in the pay items.

The labor hour bid items shall include labor and labor burdens, benefits, supervision, transportation, travel time and allowances, overnights, small tools and equipment, subcontractor overhead and profit, and General Contractor overhead and profit. Time will be measured from the start of work to the stoppage of work at the project site; less the time taken for lunch. No deduction of time will be taken for the standard morning "coffee break".

Payment will be made under:

<u>Pay Item</u>	<u>Pay Unit</u>
631.10 Air Compressor (including operator)	Hour
631.11 Air Tool (including operator)	Hour
631.115 Jackhammer (including Operator)	Hour
631.12 All Purpose Excavator (including operator)	Hour
631.171 Truck-small (including operator)	Hour
631.18 Chain Saw Rental (including operator)	Hour
631.32 Culvert Cleaner (including operator)	Hour
631.36 Foreperson	Hour
631.51 Bucket Truck	Hour
631.52 Scissor Lift	Hour
631.53 Electrician	Hour
631.54 Electrician's Apprentice	Hour

SPECIAL PROVISION

SECTION 633

PROPANE GAS UTILITY

(Propane Service Line)

633.01 Description

This work shall include furnishing and installing a new HDPE propane service line from the propane tanks to the proposed gas connection on the plaza building.

633.02 Propane Tank Connection

After completing installation of the new service line from the plaza building to the tanks, the Contractor shall coordinate with the Maine Turnpike Authority's propane supply company for connecting the service line to the tanks (to be supplied by propane supply company).

633.03 Method of Measurement

Propane Service Line satisfactorily placed and accepted shall be measured by the linear foot.

633.04 Basis of Payment

The accepted quantity of Propane Service Line will be paid for at the Contract unit price per linear foot. Payment shall be full compensation for excavation, backfill material, furnishing and installation of the new service line and all equipment, labor and incidentals necessary to complete the work.

Payment will be made under:

<u>Pay Item</u>	<u>Pay Unit</u>
633.021 Propane Service Line	Linear Foot

SPECIAL PROVISIONSECTION 634HIGHWAY LIGHTING

(Highway Lighting)

634.01 Description

The following paragraph is added:

All new luminaires shall also consist of furnishing and installing disconnect fuse kits in the pole base of light standards.

The work shall also consist of furnishing, delivering to the Authority's Sign Shop at Mile 58.3 Northbound, unloading and stacking five (5) 120-240-277V Conventional Multi-Tap LED spare luminaires. The spare luminaires shall be furnished with a fuse kit, photo cell and ROAM nodes.

One load center shall be included as detailed on the plans. Load Center No. 2 shall be a stand-alone load center/meter box installed at the intersection of the Access Drive and Chases Pond Road. Additionally, all electrical components required for the mile 8.8 lighting not included with the building electrical shall be included under this item.

634.02 General

The following paragraphs are added:

All Contract work shall be overseen by a Maine licensed Master Electrician. The lead person for the field installations shall be either a Maine licensed Master Electrician, or a Maine licensed Journeyman Electrician. Apprentice Electricians, Helper Electricians, Journeyman-In-Training Electricians, and helpers may work under the Master or Journeyman Electrician as permitted under the law.

The Contractor shall comply with National Electrical Code (NFPA 70) as applicable to construction and installation of electrical cable, wire and connectors; provide electrical cable, wire and connectors, which have been listed and labeled by Underwriters Laboratories, and comply with National Electrical Manufacturers Association/Insulated Power Cable Authorities Association Standards publications pertaining to materials, construction and testing wire cable, where applicable.

At a minimum the Contractor shall provide the following field quality control:

- Prior to energizing, check wire for continuity of circuitry and for short circuits with ohmmeter type testing equipment. Correct malfunction when detected.
- Subsequent to wire hook-ups, energize circuitry and demonstrate functioning in accordance with requirements.

634.021 Materials

The following paragraphs are added:

Disconnect fuse kits in pole bases shall be Ideal SLK Disconnect Fuse Kit 30-S2212, or similar approved Ideal SLK Disconnect Fuse Kit, matched to the pole wiring configuration. All hot and neutral wires shall be fused. Ground wires do not need to be fused.

The 120-277V Conventional Multi-Tap LED fixtures shall be one of the following:

- Model # ATB2-80BLEDE85-series, as manufactured from American Electric Lighting
- Road Focus # 241Watt 112LED 4K series, as manufactured by Philips Roadway Lighting

No substitute 120-277V Conventional Multi-Tap LED fixtures will be considered. All Luminaires located on the shoulders and at the administration building shall be equipped with house side shields.

Each luminaire shall be provided with a 7 pin NEMA receptacle, a ROAM node, a photocell and a shorting cap. All “spare” photocells and shorting caps shall become property of the Authority.

The Manufacturer shall provide a minimum 5-year warranty on all fixtures, installed and spares, from the Project Completion date.

All fixtures shall be submitted and approved before the fixtures are ordered. Submittals shall include Product Data sheets clearly identifying the product and accessories being proposed, Test Reports and Certifications, and Product Warranties.

All light poles shall be labeled with their respective pole number and circuit number with a minimum 2” letter height visible from approaching traffic. All wiring in the junction boxes shall be labeled with their applicable circuit number.

The Contractor shall supply a scaled drawing of the load center cabinet and/or wall-mounted installation showing the layout and size of each component. Load center cabinets shall be NEMA 4X rated constructed from Grade 316 Stainless Steel. The ROAM node shall be installed to each luminaire.

The Contractor shall supply and install the ROAM Concierge lighting control system with a (3) three year service package with Acuity Brands Lighting. The ROAM system shall consist of a ROAM node at each light fixture, one gateway (1 Ethernet mile 8.8, wiring for Ethernet drops, Google Maps, System Start Up and Training.

634.04 Cable Installation

The following paragraphs are added:

All conductors from load center to light poles shall be meggar tested and meggar sheets shall be submitted to MTA for approval.

634.092 Method of Measurement

Replace the second sentence with the following:

Light standards, for addition or reduction of quantity, will be measured by the single unit, complete in place and accepted.

Add the following paragraph:

LED Luminaries, for the addition or reduction of quantity, will be measured by the single unit, complete in place and accepted.

634.093 Basis of Payment

Delete Basis of Payment and replace with the following:

Lump sum payment for Highway Lighting shall be shall be full compensation for furnishing, installing and erecting the complete highway lighting system including: ballast, lamps, wiring in underground conduit, pole wiring, and all other wiring (irrespective of the number of wires or total linear feet of wire required to complete the work), transformer enclosures, luminaires, LED fixture, break-away devices when applicable, all identification tags, light standard, bracket arm, breakaway transformer base, break away devices, bracket arm, and all materials, labor, equipment, tools, miscellaneous hardware and incidentals necessary to complete the work. Payment shall also include removing and resetting light standards, and for furnishing portable electric power units.

Disconnect Fuse Kit, Installation will be considered incidental to Highway Lighting item.

Verifying the voltage of the existing luminaire(s) before installing the new LED luminaire(s) will not be paid separately, but shall be incidental to the Highway Lighting item.

Furnishing and installing Load Center shall include cabinet, foundation, panelboards, contactors, breakers, utility service connections and all components required for a fully functional system and all incidentals necessary to complete the work will not be paid separately, but shall be considered incidental to Highway Lighting item.

ROAM lighting control system shall include all nodes, gateways, Google Maps, 3 year monitoring service, system start up and training, wiring, wiring for system gateways, mounting and all incidentals to compete the work shall not be paid separately, but shall be incidental to the Highway Lighting item.

Furnishing, delivering to the Authority's Sign Shop at Mile 58.3 Northbound, unloading and stacking five (5) 120-240-277V Conventional Multi-Tap LED spare luminaire including fuse kit, photo cell and ROAM nodes, and all incidentals necessary to complete the work shall not be paid separately, but shall be incidental to the Highway Lighting item.

Payment for furnishing and installing LED Luminaires, for addition or reduction of quantity, will be made for the accepted quantity at the contract unit price of each, which shall include: ballast, lamps, wiring in underground conduit to the junction box, pole wiring, and all other wiring (except prewired conduit), transformer enclosures, luminaires, LED fixture, fuse kit, photo cell, ROAM node, all identification tags, and all materials, labor, equipment, tools, miscellaneous hardware and incidentals necessary to complete the work.

The accepted quantity of Conventional Light Standard, for addition or reduction of quantity, will be paid for at the contract unit price each, irrespective of the type or size. Payment shall be full compensation for furnishing, installing and erecting the light standard, bracket arm, breakaway transformer base, break away devices, bracket arm and all incidentals necessary to complete the work.

Payment will be made under:

<u>Pay Item</u>		<u>Pay Unit</u>
634.16	Highway Lighting	Lump Sum
634.2042	LED Luminaires	Each
634.210	Conventional Light Standard	Each

SPECIAL PROVISION

SECTION 639

ENGINEERING FACILITIES

(Field Office, Type A)

639.04 Field Offices

This Subsection is amended by the addition of the following:

The Resident’s Field Office shall be furnished and installed by the Contractor. The Contractor shall be responsible for furnishing and maintaining electricity, propane heat, and high speed wireless internet service for the entire duration of the Contract, which includes periods of time which Work has been suspended. All of the costs associated with the above shall be the responsibility of the Contractor.

639.09 Telephone

This subsection is deleted in its entirety.

639.11 Basis of Payment

This Subsection is amended by the addition of the following:

The accepted quantity of field office will be paid at the Contract unit price each which will be full payment for providing electricity, propane heat, and wireless internet service. No additional markup will be allowed.

The accepted quantity shall also include set up and demobilization of trailer for two separate locations. First location shall be in MTA York Maintenance Yard; the second location shall be in the area behind the proposed dumpster parking area.

Payment will be made under:

<u>Pay Item</u>		<u>Pay Unit</u>
639.18	Field Office Type A	Each
639.19	Field Office Type B	Each

SPECIAL PROVISIONSECTION 641FLAGPOLE

(Aluminum Flag Pole)

641.01 Description

This work shall consist of furnishing and installation of a 30 foot aluminum flagpole, ground mounted spot light and concrete foundation in accordance with these Specifications, and in reasonably close conformity with the lines and grades shown on the Plans or as approved by the Resident.

641.02 Materials

Flagpole shall be by American Flagpole, Concord Industries Inc. or EMC, a Division of Eder Manufacturing Corp.

Flagpole shall be a six inch diameter, seamless cone tapered aluminum 6063-T6 alloy, 30' height (exposed) with a mechanical Class I clear anodized finish for two flags. All fittings, such as ball finial, double revolving truck, two halyard and four snap hooks, tow cleats, and pole mounting assembly shall be as manufactured by or recommended by the flagpole manufacture.

Concrete shall be Class "A" cement concrete (4000 PSI).
Reinforcing steel shall meet the requirements of Section 503.
Lighting shall meet the requirements of Part III Division 800.

641.03 General

When flagpole is to be stored on-site for an extended period before installation, all wrapping material shall be removed and pole stored in a dry place, off the ground.

641.04 Method of Measurement

The flagpole will be measured by each unit. Lighting, conduit and wiring is included under Pay Item 800.01 Administration Building.

641.05 Basis of Payment

The accepted quantity of flagpole will be paid for at the Contract unit price each which payment shall be full compensation for furnishing and installing flagpole, and all accessories, foundation including anchor bolts, reinforcing steel, rubbing, penetration sealer, excavation, backfill, compaction, tools, equipment, labor and all incidentals necessary to complete the work.

Payment will be made under:

Pay Item

Pay Unit

641.35 Aluminum Flag Pole

Each

SPECIAL PROVISIONSECTION 643TRAFFIC

(Flashing Beacon - Solar Powered)

643.1.1 Description

The following paragraphs are added:

This special provision provides for the installation of two dual head flashing beacons at the end of each concrete barrier separating the cash lanes from the open road tolling lanes.

All provisions of Section 652, except as modified or changed below, shall apply.

1. Contractor shall furnish (12 inch) amber flashing beacons powered by solar panel with battery backup. Units shall have internal programmable timings for flash interval.
2. The beacons shall be mounted (11.5 feet) above the elevation of the adjacent edge of pavement.

643.7 Method of Measurement

The following paragraphs are added:

Flashing beacons will be measured by each unit authorized and installed on the Project.

The following list of major materials applies:

- 2 – P & K signal pole model SP-114 or approved equal.
- 2 – 12 inch amber flashing beacon powered by solar panel. Units shall be JSF Technologies FL Series -24 Hour Flashing Beacon FL -2400 or an approved equal.

643.8 Basis of Payment

The following paragraphs are added:

The accepted quantity of Flashing Beacon – Solar Powered will be paid for at the Contract unit price per unit. This price shall be full compensation for all labor, materials and equipment necessary to furnish and install Flashing Beacons.

Payment will be made under:

<u>Pay Item</u>	<u>Pay Unit</u>
643.63 Flashing Beacon – Solar Powered	Each

SPECIAL PROVISIONSECTION 643TRAFFIC SIGNALS

(Lane Use Signal Installation)

643.01 Description

This work shall consist of supply and installation of lane use signals (Non-Flashing). All equipment, installation of equipment and other incidental work shall conform to the latest applicable provisions of: NEC, MUTCD, NESC, NEMA, and the ITE Standards for traffic control equipment. All work shall be done to the satisfaction of the Resident. The meaning of specific terms shall be as defined in MUTCD, NESC, and the ITE Standards for traffic control equipment.

643.02 Materials

The lane use signal heads shall be Trans-Tech DOT2424RG-175 or approved equal. See Appendix for technical product details.

643.03 Installation

The new lane use signal housing and LED signal shall be installed and wired over the center of the new lane. New Pelco (or equal) mounting brackets may be needed and will be incidental to the installation of the new lane use signal. The Contractor shall provide a 1-year warranty on all material and workmanship related to the installation of the new lane use signal. Installation of the Lane Use Signal shall also include the installation of the MTA provided canopy override switch (COS) and all needed wiring and incidentals from the power source to the COS and to the lane use signal.

643.04 Method of Measurement

Lane use signals will be measured by each unit, installed and accepted.

643.05 Basis of Payment

Lane Use Signals will be paid for at the Contract unit price each which payment shall be full compensation for the furnishing and installation of new lane use signals, and all other materials, labor, tools, equipment and incidentals necessary to complete the work.

Payment will be made under:

<u>Pay Item</u>	<u>Pay Unit</u>
643.712 Lane Use Signal	Each

SPECIAL PROVISIONSECTION 645HIGHWAY SIGNING

(Canopy Mounted Dynamic Message Sign)

645.01 Description

This work shall consist of the installation of a canopy mounted dynamic message sign (DMS) located above one cash lane of the new York Toll Plaza. All needed electrical and communication wiring will be included as part of the installation. The sign is mounted on framing supports and mounted on brackets to the top of the toll plaza canopy.

The Contractor shall provide existing power wiring and two (2) direct burial type, Category 5e cables and needed conduit for the DMS sign to be connected. Both Category 5e cables shall be connected to the lane controller in the tunnel. Ten (10) feet of slack cable for routing of the cable within the booth shall be provided. The Contractor shall coordinate with the MTA Toll System and ITS Manager for sign installation.

645.02 Materials

The DMS to be installed at the new York Toll Plaza will be the following:

Daktronics model VC6-64x160-19.8-RGB-SF or approved equal.

Sign shall also include a DM-100 hand controller.

645.04 Method of Measurement

Canopy Mounted Dynamic Message Sign shall be measured as complete units each for provision and installations accepted by the MTA.

645.05 Basis of Payment

Canopy Mounted Dynamic Message Sign shall be full compensation for furnishing and the installation of the new DMS framing supports, brackets and for all other materials, labor tools, equipment and incidentals necessary to complete the work. The item also includes all necessary electrical and communication wiring.

Payment will be made under:

<u>Pay Item</u>	<u>Pay Unit</u>
645.1092 Canopy Mounted Dynamic Message Sign	Each

SPECIAL PROVISIONSECTION 645HIGHWAY SIGNING

(Overhead Guide Sign)

645.09 Basis of Payment

This subsection is amended by the addition of the following:

Foundations (concrete pedestals and drilled shafts) shown on Sheet Nos. S-45 and S-46 for the overhead guide sign support structures shall not be included under the Section 645 Pay Items listed below. These foundations will be paid for under the following Pay Items:

- 1) Item No. 502.231 – Structural Concrete, Space Frame and Overhead Sign Support Structure Pedestals [concrete for pedestals]
- 2) Item No. 503.14 – Epoxy-Coated Reinforcing Steel, Fabricated and Delivered [steel reinforcement for pedestals]
- 3) Item No. 503.15 – Epoxy-Coated Reinforcing Steel, Placing [steel reinforcement for pedestals]
- 4) Item No. 626.3321 – 36-Inch Diameter Drilled Shaft [drilled shaft section in soil]
- 5) Item No. 626.3322 -30-Inch Diameter Drilled Shaft – Rock Socket [drilled shaft section in rock]

Rock and soil excavation, dewatering, temporary excavation support, and fine grading work for installation of concrete pedestal foundations shall be incidental to the Section 645 Pay Items listed below.

Payment will be made under:

<u>Pay Item</u>		<u>Pay Unit</u>
645.121	Overhead Guide Sign 1 (Sta. 281+45 NB)	Lump Sum
645.122	Overhead Guide Sign 2 (Sta. 306+65 NB)	Lump Sum
645.123	Overhead Guide Sign 3 (Sta. 318+81 NB)	Lump Sum
645.124	Overhead Guide Sign 4 (Sta. 332+00 NB)	Lump Sum
645.125	Overhead Guide Sign 5 (Sta. 359+50 SB)	Lump Sum
645.126	Overhead Guide Sign 6 (Sta. 374+50 SB)	Lump Sum
645.127	Overhead Guide Sign 7 (Sta. 382+50 SB)	Lump Sum
645.128	Overhead Guide Sign 8 (Sta. 414+90 SB)	Lump Sum

SPECIAL PROVISION

SECTION 645

HIGHWAY SIGNING

(Remove and Reset Sign)

(Remove and Stack Sign)

645.07 Demounting and Reinstalling Existing Signs and Poles

The following paragraphs are added:

At locations noted on the Plans, existing ground-mounted signs are designated to be removed and reset. This work shall consist of removing the sign panels, removing and resetting or disposing of the existing wood post and resetting the sign panels on a new wood post if required in the appropriate specified location. The Resident will determine if a new wood post is required.

At locations as shown on the Plans, existing ground-mounted signs and overhead mounted signs are designated to be removed and stacked. This work shall consist of removing and delivering existing sign panels, posts, concrete foundations, steel bridge sign supports and breakaway devices to the MTA Sign Shop at Mile 58 NB. All aluminum sign support structures shall be disposed of by the Contractor.

Excavations shall be backfilled and ground restored to the satisfaction of the Resident. Existing foundations for overhead sign structures shall be abandoned by removing the foundation to 6 inches below finished grade and disposed.

Any existing signs not shown on the Plans are to remain in their existing condition unless directed otherwise by the Resident.

645.08 Method of Measurement

The following sentences are added:

Removing and Resetting existing ground-mounted signs shall be measured as complete unit each, removed, reset and accepted.

Removing and stacking existing signs, regardless of the type of sign stacked, shall be measured as complete units each removed and stacked.

645.09 Basis of Payment

The following paragraphs are added:

The accepted signs removed and stacked shall be paid for at the Contract unit price each as specified for each type of sign designated on the plans. Such price shall include removing and

stacking sign panels and supports, and removing or abandoning foundations at the location specified.

The accepted signs Removed and Reset will be paid for at the Contract unit price each as specified. Such price will include removing and resetting sign panels, removing and resetting or disposing existing wood post and resetting the sign panels on the existing or new wood post and new hardware as required to complete the sign installation. Any signs or supports damaged by the Contractor shall be replaced by him with new signs or supports conforming to the applicable Specifications at no additional cost to the Authority.

Payment will be made under:

<u>Pay Item</u>	<u>Pay Unit</u>
645.105 Remove and Stack Sign	Each
645.1051 Remove and Stack Ground Mount Sign and Structure	Each
645.109 Remove and Reset Sign	Each
645.501 Remove and Reset Mainline Sign 1	Lump Sum
645.502 Remove and Reset Mainline Sign 2	Lump Sum
645.503 Remove and Reset Mainline Sign 3	Lump Sum

SPECIAL PROVISION

SECTION 645

HIGHWAY SIGNING

(Canopy Mounted Sign)

645.01 Description

The following paragraph is added:

Canopy mounted signs are defined as signs fabricated from sheet aluminum as identified in the Plans. Each static sign is mounted on framing supports and mounted on brackets to the top of the toll plaza canopy with an attached luminaire.

The following Subsection is added:

645.08 Method of Measurement

The following sentence is added:

Canopy Mounted Signs will be measured by each complete unit of the kind specified and installed.

645.09 Basis of Payment

The following paragraphs are added:

The accepted quantity of Canopy Mounted Signs shall be paid for at the Contract unit price each as specified. Such price shall include all hardware, labor and equipment necessary to complete this task. The item also includes all necessary electrical wiring.

Payment will be made under:

<u>Pay Item</u>	<u>Pay Unit</u>
645.14 Canopy Mounted Sign	Each

SPECIAL PROVISION

SECTION 645

HIGHWAY SIGNING

(Canopy Mounted DMS Remove and Reset)

645.01 Description

The following paragraph is added:

The removal and resetting of the existing canopy mounted DMS on the southbound approach shall be paid under this item. The sign is mounted on framing supports on top of the toll plaza canopy.

The following Subsection is added:

645.08 Method of Measurement

The following sentence is added:

Canopy Mounted DMS Remove and Reset shall be measured as a complete unit for each DMS removed and reset.

645.09 Basis of Payment

The following paragraphs are added:

The accepted quantity of Canopy Mounted DMS Remove and Reset shall be paid for at the Contract unit price each for each DMS as specified. Such price shall include removing sign panels and hardware framing supports, sign controllers and all electrical components associated with the signs and re-installing on the new toll plaza canopy. This includes all hardware, wiring, configuration, labor and equipment necessary to complete this task.

Any signs, or supports damaged by the Contractor shall be replaced with new signs or supports conforming to the applicable Specifications at no additional cost to the Authority.

Pay Item

Pay Unit

645.141	Canopy Mounted DMS Remove and Reset	Each
---------	-------------------------------------	------

SPECIAL PROVISION

SECTION 645

HIGHWAY SIGNING

(Variable Speed Limit Sign)

645.01 Description

The following sentence is added:

This work shall also include the fabrication and installation of new Variable Speed Limit Signs on the NB and SB Space Frame.

645.021 Materials

The following paragraph is added at the end of this Subsection:

The Variable Speed Limit Sign shall be manufactured by Daktronics or approved equal, Vanguard model VS-5220 VSLS. A detail will be provided in Appendix E.

645.08 Method of Measurement

The following sentence is added:

Variable Speed Limit Signs will be measured by each unit in place.

645.09 Basis of Payment

Payment will be made under:

<u>Pay Item</u>		<u>Pay Unit</u>
645.155	Variable Speed Limit Sign	Each

SPECIAL PROVISION

SECTION 645

HIGHWAY SIGNING

(Wood Post)

645.01 Description

The following sentence is added:

This work shall include installing a 6" x 6" pressure treated wood post which is break away and foundation for all signs as specified on the Sign Summary Plans.

645.021 Materials

The following paragraph is added at the end of this Subsection:

The wood post shall be to Maine Turnpike or Section 720.12 of the Maine DOT Standard Specifications.

645.08 Method of Measurement

The following sentence is added:

Wood Post will be measured by each unit in place.

645.09 Basis of Payment

The following paragraphs are added:

The accepted quantity of Wood Posts shall be paid for at the Contract unit price each as specified. Such price shall include all hardware, labor and equipment necessary to complete this task.

Payment will be made under:

Pay Item

Pay Unit

645.28 Wood Post

Each

SPECIAL PROVISION

SECTION 652

MAINTENANCE OF TRAFFIC

(Flaggers)

The following section of the Supplemental Specification Section 652 has been revised as follows:

Section 652.2.4 Other Devices

Paragraph five is deleted and replaced with:

STOP/SLOW paddles shall be the primary and preferred hand-signaling device. Flags shall be limited to emergencies. The paddle shall have an octagonal shape and be at least 18 inches wide with letters at least 6 inches high and should be fabricated from light semi-rigid material.

Section 652.4 Flaggers

Last sentence in first paragraph is deleted and replaced with:

Only flashing SLOW/STOP paddles shall be used and the flagger station shall be illuminated to assure visibility in accordance with 652.6.2.

The following paragraph is added:

Flaggers are not permitted to stop traffic on mainline or ramps.

652.7 Method of Measurement

The following paragraph is added:

Flaggers shall only be measured for payment when utilized on Chase's Pond Road when the Contractor is actively working within 200 feet of Chase's Pond Road. Flaggers used for the convenience of the Contractor, will not be measured for payment and shall be considered incidental to the various pay items.

SPECIAL PROVISIONSECTION 652MAINTENANCE OF TRAFFIC

(Specific Project Maintenance of Traffic Requirements)

This Specification describes the specific project maintenance of traffic requirements for this Project.

The following minimum traffic requirements shall be maintained. These requirements may be adjusted based on the traffic volume when authorized by the Authority.

Local Road Traffic Control Requirements

Two lanes of traffic (one in each direction) on Chases Pond Road shall be maintained at all times. For construction of the new access road connection at Chases Pond Road, standard lane or shoulder closures shall be developed by the Contractor from the typical details provided in the Plans. All operations requiring lane and/or shoulder closures shall be approved by the Resident prior to start of work.

Maine Turnpike Traffic Control Requirements

All work shall be performed within Supplemental Specification 107.3 Allowable Work Times.

Three-lane traffic in each direction shall be maintained on I-95 at all times, unless when one or two lanes of traffic are allowed by these Specifications and Plans. Minimum shoulder widths on both sides of the travel lanes shall be provided at all times, unless allowed under "Temporary Shoulder Closures" in the tables below.

Maintenance of Traffic plans have been developed for three major phases of construction, Phase 1, 2 and 3, which provide for three lanes of traffic in each direction. The exception is Phase A and B which allow for two lanes of traffic in each direction for the construction of a portion of the I-95 improvements for a limited duration. The Contractor shall schedule this work in accordance with the requirements provided in the tables below.

For all other operations, standard lane or shoulder closures shall be developed by the Contractor from the typical details provided in the Plans and shall coordinate and not conflict with the traffic control devices set up for Phases 1, 2 and 3, and Phase A and B. All operations requiring lane and/or shoulder closures shall be approved by the Resident prior to start of work.

During the erection and removal of overhead structures or signs, traffic may be stopped and held for periods no longer than 25 minutes during these operations. Before the roadway is opened, all materials shall be properly attached and secured, or removed from traffic so as to not endanger traffic passing underneath. The Contractor shall reimburse the Authority at a rate of \$2500.00 per five-minute period beyond the 25 minute maximum time limit that each roadway (northbound and southbound) is not reopened to traffic.

TABLE 1 - Mainline Northbound						
September 10, 2018 to June 14, 2019						
September 9, 2019 June 12, 2020						
September 14, 2020 to June 11, 2021						
	Erection / Removal of Overhead Structures/ Signs	Equipment Moves	Temporary Single Lane Closures ¹	Temporary Double Lane Closures ³	Temporary Shoulder Closures	
Days of Week:	Monday through Thursday					
	6:00 a.m. to 6:00 p.m.		Allowed	Allowed ²		Allowed
	6:00 a.m. to 9:00 a.m.		Allowed	Allowed		Allowed
Days of Week:	Sunday Night through Friday Morning					
	6:00 p.m. to 6:00 a.m. following day		Allowed	Allowed		Allowed
	10:00 p.m. to 6:00 a.m. following day		Allowed	Allowed	Allowed	Allowed
	10:00 p.m. to 5:00 a.m. following day	Allowed	Allowed	Allowed	Allowed	Allowed
Day of Week:	Friday					
	6:00 a.m. to 8:00 p.m.		Allowed	Allowed ⁴		Allowed
Days of Week:	Friday Night through Saturday Morning					
	8:00 p.m. (Friday) to 8:00 a.m. (Saturday)		Allowed	Allowed		Allowed
	11:00 p.m. (Friday) to 5:00 a.m. (Saturday)	Allowed	Allowed	Allowed	Allowed	Allowed

Days of Week:	Saturday Night through Sunday Morning					
	6:00 p.m. (Saturday) to 9:00 a.m. (Sunday)		Allowed	Allowed		Allowed
	8:00 p.m. (Saturday) to 9:00 a.m. (Sunday)		Allowed	Allowed	Allowed	Allowed

- From October 15 to November 16, 2018, or from April 1 to May 6, 2019, or from October 14 to November 15, 2019, or from March 30 to May 4, 2020, a permanent single lane closure will be allowed for Phase A and Phase B (see Special Provision 107.4.6 and the Maintenance of Traffic plans).
- Monday through Thursday:

Single Lane closure NOT allowed between the hours of 9:00 a.m. and 5:00 p.m. for the following dates:

Year	2018	2019	2020	2021
Dates	November 15 - 26	November 21 - December 2	November 19 - 30	November 19 - 29

- Monday through Thursday:

Double Lane closure NOT allowed for the following dates:

Year	2018	2019	2020	2021
Dates	February 16 – 26	February 15 – 25	February 14 – 24	February 12 – 22
	April 20 – June 15	April 19 – June 14	April 17 – June 12	April 16 – June 11
	September 14 – October 8	September 13 – October 7	September 11 – October 5	September 10 – October 4
	November 2 – 12	November 1 – 11	October 30 – November 9	October 29 – November 8

4. Friday:

Single Lane closure NOT allowed between the hours of 8:00 a.m. to 8:00 p.m. for the following dates:

Year	2018	2019	2020	2021
Dates	April 27 - June 15	April 26 - June 14	April 24 - June 12	April 23 - June 11

TABLE 2 - Mainline Southbound						
September 10, 2018 to June 14, 2019						
September 9, 2019 June 12, 2020						
September 14, 2020 to June 11, 2021						
		Erection / Removal of Overhead Structures/ Signs	Equipment Moves	Temporary Single Lane Closures ¹	Temporary Double Lane Closures	Temporary Shoulder Closures
Days of Week:	Monday through Thursday					
	6:00 a.m. to 6:00 p.m.		Allowed	Allowed ²		Allowed
Days of Week:	Sunday Night through Friday Morning					
	6:00 p.m. to 6:00 a.m. following day		Allowed	Allowed		Allowed
	9:00 p.m. to 5:00 a.m. following day		Allowed	Allowed	Allowed	Allowed
	10:00 p.m. to 5:00 a.m. following day	Allowed	Allowed	Allowed	Allowed	Allowed
Day of Week:	Friday					
	6:00 a.m. to 6:00 p.m.		Allowed	Allowed		Allowed
Days of Week:	Friday Night through Saturday Morning					
	6:00 p.m. (Friday) to 8:00 a.m. (Saturday)		Allowed	Allowed		Allowed
	7:00 p.m. (Friday) to 8:00 a.m. (Saturday)		Allowed	Allowed	Allowed	Allowed

	10:00 p.m. (Friday) to 5:00 a.m. (Saturday)	Allowed	Allowed	Allowed	Allowed	Allowed
Days of Week:	Saturday Night through Sunday Morning					
	6:00 p.m. (Saturday) to 9:00 a.m. (Sunday)		Allowed	Allowed	Allowed ³	Allowed

1. From October 15 to November 16, 2018, or from April 1 to May 6, 2019, or from October 14 to November 15, 2019, or from March 30 to May 4, 2020, a permanent single lane closure will be allowed for Phase A and Phase B (see Special Provision 107.4.6 and the Maintenance of Traffic plans.

2. Monday through Thursday:

Single Lane closure NOT allowed between the hours of 9:00 a.m. and 2:00 p.m. for the following dates:

Year	2018	2019	2020	2021
Dates	November 15 - 26	November 21 – December 2	November 19 - 30	November 19 – 29

3. Saturday Night through Sunday Morning:

Double Lane closure NOT allowed between the hours of 7:00 a.m. and 9:00 a.m. for the following dates:

Year	2018	2019	2020	2021
Dates	September 10 – October 1	September 9 – 30	September 14 – October 5	September 13 – October 4

TABLE 3 - Mainline Northbound

June 15, 2019 to September 8, 2019
June 13, 2020 to September 13, 2020
June 12, 2021 to September 12, 2021

	Erection and Removal of Overhead Structures/ Signs	Equipment Moves	Temporary Single Lane Closures	Temporary Double Lane Closures	Temporary Shoulder Closures
Days of Week:	Monday through Thursday				
	6:00 a.m. to 9:00 a.m.		Allowed	Allowed	Allowed
Days of Week:	Sunday Night through Friday Morning				
	6:00 p.m. to 6:00 a.m. following day		Allowed	Allowed ¹	Allowed
	11:00 p.m. to 6:00 a.m. following day		Allowed	Allowed	Allowed
	11:00 p.m. to 5:00 a.m. following day	Allowed	Allowed	Allowed	Allowed
Day of Week:	Friday				
	6:00 a.m. to 8:00 a.m.		Allowed	Allowed	Allowed
Days of Week:	Friday Night through Saturday Morning				
	9:00 p.m. (Friday) to 8:00 a.m. (Saturday)		Allowed	Allowed	Allowed
	11:00 p.m. (Friday) to 6:00 a.m. (Saturday)		Allowed	Allowed	Allowed
	11:00 p.m. (Friday) to 5:00 a.m. (Saturday)	Allowed	Allowed	Allowed	Allowed

Days of Week:	Saturday Night Through Sunday Morning					
	6:00 p.m. (Saturday) to 8:00 a.m. (Sunday)		Allowed	Allowed		Allowed
	9:00 p.m. (Saturday) to 7:00 a.m. (Sunday)		Allowed	Allowed	Allowed	Allowed

1. Sunday Night through Friday Morning:

Single Lane closure NOT allowed from 6:00 p.m. to 11:00 p.m. for the following dates:

Year	2018	2019	2020	2021
Dates	June 29 - July 9	June 28 – July 8	June 26 – July 7	June 25 – July 6

The remainder of this page intentionally blank

TABLE 4 - Mainline Southbound**June 15, 2019 to September 8, 2019****June 13, 2020 to September 13, 2020****June 12, 2021 to September 12, 2021**

	Erection and Removal of Overhead Structures/ Signs	Equipment Moves	Temporary Single Lane Closures	Temporary Double Lane Closures	Temporary Shoulder Closures
Days of Week:	Monday through Thursday				
	6:00 a.m. to 6:00 p.m.		Allowed	Allowed ¹	Allowed
Day of Week:	Sunday Night through Monday Morning				
	9:00 p.m. to 6:00 a.m. following day		Allowed	Allowed ²	Allowed
	11:00 p.m. to 5:00 a.m. following day	Allowed	Allowed	Allowed	Allowed
Day of Week	Monday Night through Friday Morning				
	6:00 p.m. to 6:00 a.m. following day		Allowed	Allowed	Allowed
	10:00 p.m. to 5:00 a.m. following day	Allowed	Allowed	Allowed	Allowed
Day of Week:	Friday				
	6:00 a.m. to 6:00 p.m.		Allowed	Allowed ¹	Allowed
Days of Week:	Friday Night through Saturday Morning				
	6:00 p.m. (Friday) to 7:00 a.m. (Saturday)		Allowed	Allowed	Allowed
	9:00 p.m. (Friday) to 6:00 a.m. (Saturday)		Allowed	Allowed	Allowed
	10:00 p.m. (Friday) to 5:00 a.m. (Saturday)	Allowed	Allowed	Allowed	Allowed

Days of Week:	Saturday Night through Sunday Morning					
	6:00 p.m. (Saturday) to 8:00 a.m. (Sunday)		Allowed	Allowed		Allowed
	11:00 p.m. (Saturday) to 7:00 a.m. (Sunday)		Allowed	Allowed	Allowed	Allowed

1. Monday through Thursday
Friday

Single Lane closure NOT allowed from 10:00 a.m. to 5:00 p.m. for the following dates:

Year	2018	2019	2020	2021
Dates	August 3 – 27	August 2 - 26	July 31 – August 24	July 30 – August 23

2. Sunday Night through Monday Morning

Single Lane closure NOT allowed from 9:00 p.m. to 11:00 p.m. for the following dates:

Year	2018	2019	2020	2021
Dates	June 28 – July 9	June 27 – July 8	July 1 – July 13	July 1 to July 12

The remainder of this page intentionally blank

SPECIAL PROVISIONSECTION 652MAINTENANCE OF TRAFFIC

(Allowable Blasting Time)

This Specification describes the specific project Allowable Blasting Time for this Project.

These requirements may be adjusted based on the traffic volume when authorized by the Authority.

Unless specified in the Allowable Blasting Times tables (Calendar Years 2018 – 2021) below, the use of explosives is NOT permitted on Fridays, weekends (Saturday and Sunday), holidays, on the eve of a holiday, extended holiday periods, or during non-daylight-hours unless approved in writing by the Authority. A blast may be allowed early on a Friday morning before 6:00 a.m. if it can be completed during daylight-hours.

Note that the times frames specified in the following tables may include holidays, eve of holidays, and extended holiday periods. This shall not be construed that blasting is allowed during these NON-PERMITTED times.

YEAR 2018 – ALLOWABLE BLASTING TIMES	
Weekday	
October 22 – 25	10:00 a.m. – 1:00 p.m.
October 29 – November 2 November 5 – 8, November 12 – 16	9:00 a.m. – 2:00 p.m.
December 3 – 6 December 10 – 13	9:00 a.m. – 2:00 p.m.

The remainder of this page intentionally blank

YEAR 2019 – ALLOWBLE BLASTING TIMES	
Weekday	
January 7 – 10, January 14 – 17 January 22 – 24 *, January 28 – 31 February 4 – 7, February 11 – 14	9:00 a.m. – 3:00 p.m.
February 25 – 28, March 4 – 7 March 11 – 14, March 18 – 21 March 25 – 28, April 1 – 4 April 8 - 12	9:00 a.m. – 2:00 p.m.
April 15 – 18	6:00 a.m. – 7:00 a.m., 9:00 a.m. – 1:00 p.m.
April 22 – 25	6:00 a.m. – 7:00 a.m.
April 29 – May 2	6:00 a.m. – 7:00 a.m., 9:00 a.m. – 2:00 p.m.
May 6 – 9, May 13 – 16, May 20 - 23	6:00 a.m. – 7:00 a.m.
June 3 – 6, June 10 – 13 June 17 – 20, June 24 - June 27	5:00 a.m. – 7:00 a.m.
July 1 – July 3, July 8 – 11 July 15 – 18, July 22 – 25 July 29 – August 1, August 5 – 8 August 12 – 15	6:00 a.m. – 7:00 a.m.
October 21 – October 24	10:00 a.m. – 1:00 p.m.
October 28 – 31, November 4 – 7 November 11 – 14, November 18 - 21	9:00 a.m. – 2:00 p.m.
December 2 – 5, December 9 - 12	9:00 a.m. – 2:00 p.m.
Friday	
January 4, 11, 18, 25 February 1	8:00 a.m. – 12:01 p.m. (Noon)
February 8, 22 March 1	7:00 a.m. – 11:00 a.m.
March 8, 15, 22, 29	7:00 a.m. – 9:00 a.m.
April 5, 12	7:00 a.m. – 8:00 a.m.
April 18, 26 May 3	6:00 a.m. – 7:00 a.m.
Saturday	
January 5, 12 ,19	8:00 a.m. – 10:00 a.m.
January 26 February 2	8:00 a.m. – 11:00 a.m.
February 9	7:00 a.m. – 11:00 a.m.
March 2, 9, 16, 23, 30	7:00 a.m. – 10:00 a.m.
April 6, 13	7:00 a.m. – 9:00 a.m.
April 20, 27 May 4	6:00 a.m. – 9:00 a.m.

YEAR 2020 – ALLOWABLE BLASTING TIMES	
Weekday	
January 6 – 9, January 13 – 15 January 21 - 23 *, January 27 – 31 February 3 – 6, February 10 - 13	9:00 a.m. – 3:00 p.m.
February 24 – 27, March 2 – 5 March 9 – 12, March 16 – 19 March 23 – 26, March 30 – April 2 April 6 - 10	9:00 a.m. – 2:00 p.m.
April 13 – April 16	6:00 a.m. – 7:00 a.m., 9:00 a.m. – 1:00 p.m.
April 20 - 23	6:00 a.m. – 7:00 p.m.
April 27 - 30	6:00 a.m. – 7:00 a.m., 9:00 a.m. – 2:00 p.m.
May 4 – 7, May 11 – 14, May 18 - 21	6:00 a.m. – 7:00 a.m.
June 1 – 4, June 8 – 11 June 15 – 18, June 22 - 25	5:00 a.m. – 7:00 a.m.
June 29 – July 2, July 6 – 9 July 13 – 16, July 20 – 23 July 27 – 30, August 3 – 6 August 10 - 13	6:00 a.m. – 7:00 a.m.
October 19 - 22	10:00 a.m. – 1:00 p.m.
October 26 – 29, November 2 – 5 November 9 – 12, November 16 – 19	9:00 a.m. – 2:00 p.m.
November 30 – December 3 December 7 - 10	9:00 a.m. – 2:00 p.m.
Friday	
January 3, 10, 17, 24, 31	8:00 a.m. – 12:01 p.m. (Noon)
February 7, 14, 21, 28	7:00 a.m. – 11:00 a.m.
March 6, 13, 20, 27	7:00 a.m. – 9:00 a.m.
April 3, 10	7:00 a.m. – 8:00 a.m.
April 17, 24 May 1	6:00 a.m. – 8:00 a.m.
Saturday	
January 4, 11, 18	8:00 a.m. – 10:00 a.m.
January 25 February 1	8:00 a.m. – 11:00 a.m.
February 8	7:00 a.m. – 11:00 a.m.
February 15	7:00 a.m. – 9:00 a.m.
February 22, 29 March 7, 14, 21, 28	7:00 a.m. – 10:00 a.m.
April 4, 11	7:00 a.m. – 9:00 a.m.
April 18, 25 May 2	6:00 a.m. – 9:00 a.m.

YEAR 2021 – ALLOWABLE BLASTING TIMES	
Weekday	
January 4 – 7, January 11 – 14 January 19 - 21, January 25 – 28 February 1 – 4, February 8 – 11	9:00 a.m. – 3:00 p.m.
February 22 – 25, March 1 – 4 March 8 – 11, March 15 – 18 March 22 – 25, March 29 – April 1 April 5 - 8	9:00 a.m. – 2:00 p.m.
April 12 – April 15	6:00 a.m. – 7:00 a.m. 9:00 a.m. – 1:00 p.m.
April 19 - 22	6:00 a.m. – 7:00 p.m.
April 26 - 29	6:00 a.m. – 7:00 a.m., 9:00 a.m. – 2:00 a.m.
May 3 – 6, May 10 – 13, May 17 - 20	6:00 a.m. – 7:00 a.m.
May 31 – June 4, June 7 – 10 June 14 – 17, June 21 - 24	5:00 a.m. – 7:00 a.m.
June 28 – July 1, July 5 – 8 July 12 – 15, July 19 – 22 July 26 – 29, August 2 – 5 August 9 – 12	6:00 a.m. – 7:00 a.m.
October 18 – October 21	10:00 a.m. – 1:00 p.m.
October 25 – 28, November 1 – 4 November 8 – 11, November 15 – 18	9:00 a.m. – 2:00 p.m.
November 29 – December 2 December 6 – 9	9:00 a.m. – 2:00 p.m.
Friday	
January 1, 8, 15, 22, 29	8:00 a.m. – 12:01 p.m. (Noon)
February 5, 26	7:00 a.m. – 11:00 a.m.
March 5, 12, 19, 26	7:00 a.m. – 9:00 a.m.
April 2, 9	7:00 a.m. – 8:00 a.m.
April 16, 23, 30	6:00 a.m. – 8:00 a.m.
Saturday	
January 2, 9, 16	8:00 a.m. – 10:00 a.m.
January 23, 30	8:00 a.m. – 11:00 a.m.
February 6	7:00 a.m. – 11:00 a.m.
February 20, 27 March 6, 13, 20, 27	7:00 a.m. – 10:00 a.m.
April 3, 10	7:00 a.m. – 9:00 a.m.
April 17, 24 May 1	6:00 a.m. – 9:00 a.m.

SPECIAL PROVISIONSECTION 652MAINTENANCE OF TRAFFIC

(Truck Mounted Attenuator)

Section 652 of the Maine Turnpike Authority 2016 Supplemental Specifications is modified as follows:

652.1 Description

The following paragraph is added:

When a pay item for a Truck Mounted Attenuator (TMA) is included in the contract at least one TMA will be required on the project and its use will be required. The truck mounted attenuator should be utilized in lane closures and other construction operations where workers are exposed to traffic and not protected by other positive means. The Contractor shall manage the utilization and operation of the TMA and if at least one is not used as described above then it will be considered a Traffic Control Plan violation and result in a reduction of payment as outlined in Section 652.

652.2.1 Truck Mounted Attenuator

This section is deleted in its entirety and replaced with the following:

The truck mounted attenuator system shall conform to the following requirements:

- Truck and attached attenuator shall conform to the NCHRP Report 350, Test Level 3 criteria.
- A mounted revolving amber light or amber strobe light with 360-degree visibility.
- An arrow light bar fixed to the vehicle.
- The attenuator shall be mounted to a vehicle with a minimum weight of 10,000 lbs.

652.3.7 Operations

This section is deleted in its entirety and replaced with the following:

The Contractor shall manage the operation of the truck mounted attenuator. The truck mounted attenuator should be utilized in lane closures and other construction operations where workers are exposed to traffic and not protected by positive means. The operation of the vehicle shall be in accordance with the Manual of Uniform Traffic Control Devices and the manufacturer's recommendation.

Installation: The chart below identifies the distance from the work zone or hazard where the TMA shall be deployed. If the work zone is within a marked lane closure, the barrier truck distances shall apply and if the work is mobile, then shadow truck distances shall apply. The TMA shall not be located in the buffer zone. When used as a barrier, the barrier truck shall be

parked in low gear with brakes applied and the front wheels turned away from the work zone and the adjacent traffic lane. For placement details, reference the Manual of Uniform Traffic Control Devices (MUTCD).

Weight of Truck	Barrier Truck Distance from Work Zone of Hazard	Shadow Truck Distance from Work Vehicle or Work Zone
10,000 lbs	250 ft	300 ft
15,000 lbs	200 ft	250 ft
>24,000 lbs	150 ft	200 ft

652.7 Method of Measurement

The last paragraph is deleted and replaced with:

Truck mounted attenuator shall be measured for payment by the calendar day for each calendar day that a unit is used on a travel lane or shoulder on the project, as approved by the resident.

652.8.2 Basis of Payment

The last two paragraphs are deleted and replaced with:

The Truck Mounted Attenuator(s) will be paid for at the Contract unit price per calendar day for each TMA used. This price shall include all costs associated with the use of the vehicle. Payment shall include operator, fuel, truck, maintenance, flashing lights, arrow board and all other incidentals necessary to operate the vehicle.

Payment will be made under:

<u>Pay Item</u>	<u>Pay Unit</u>
652.45 Truck Mounted Attenuator	Calendar Day

SPECIAL PROVISIONSECTION 652MAINTENANCE OF TRAFFIC(Automated Speed Limit Sign)652.1 Description

This special provision provides for furnishing, operating, and maintaining an Automated Trailer Mounted Radar Speed Limit Sign for project use. When a pay item for an Automated Trailer Mounted Radar Speed Limit Sign is included in the Contract at least one will be required on the project when there is a Work Zone Speed Limit in place. The Contractor shall furnish, operate, and maintain the Automated Trailer Mounted Radar Speed Limit Signs during the project operations.

652.1.1 Instruction and maintenance manuals shall be provided.

652.2 MaterialsAutomated Trailer Mounted Speed Limit Sign

Trailer mounted speed limit signs shall be self-contained units including sign assembly, flashing lights, directional radar to measure speed limits, a regulatory speed limit sign, and power supply specifically constructed to operate as a trailer-mounted sign. The preferred color of the unit shall be “construction orange”.

Signs

Base material for the regulatory speed limit signs shall be weather proof, rigid substrate specifically manufactured for highway signing and meet the retro-reflective sheeting application requirements of the sheeting manufacturer.

Sign text shall consist of the letters, digits and symbols either applied by stick-on or silk screen, to conform to the dimensions and designs indicated in the Contract, MUTCD and/or FHWA Standard Highway Signs. The materials and methods shall be in accordance with standard commercial processes.

“Work Zone” construction signs shall be mounted on the trailer unit above the regulatory speed limit sign. (see Appendix).

Signs and secondary signs shall follow the MUTCD for minimum mounting heights.

Power supply

The power supply shall be either full battery power with solar panel charging (capable of maintaining a charged battery level) and 135 ampere, 12 volt deep cycle batteries, or diesel powered generator with a fuel capacity sufficient for 10 hours of continuous operation.

Flashing Lights

Each unit shall be equipped with two mono-directional flashing lights, placed in accordance with the MUTCD, with amber lenses and reflectors, which are visible through a range of 120 degrees when viewed facing the sign. The lights, either strobe, halogen, or incandescent lamps, shall be visible for a minimum distance of one mile under daylight conditions and shall have a minimum flash rate of 40 flashes per minute. An "On" indicator light shall be mounted on the back of the signs, which is visible for at least 500 feet to provide confirmation that the flashing lights are operating.

Radar

The directional radar shall monitor approaching traffic only. The radar shall be capable of measuring speeds from 5 to 70 MPH at a distance of up to 1500 feet and shall have a high speed cut off threshold.

CONSTRUCTION REQUIREMENTS

652.3.2 Responsibility of the Contractor

The Contractor shall furnish the Automated Trailer Mounted Speed Limit Sign as described in this Special Provision for this project.

All existing speed limit signs, which conflict with the construction zone trailer mounted speed limit signs shall be covered completely when the work zone speed limit is in place.

Automated Trailer Mounted Speed Limit Signs shall only be used when a work zone speed limit is in place. The Contractor shall manage the utilization and operation of the Automated Trailer Mounted Speed Limit Signs and if at least one is not used when work zone speed limits are in place then it will be considered a Traffic Control Plan violation and result in a reduction of payment as outlined in Section 652.

The Resident will record the actual time and location for the signs on a daily basis when the Automated Trailer Mounted Speed Limit Signs are in use.

The Automated Trailer Mounted Radar Speed Limit Sign may be placed as shown on the plans, or may replace the posted regulatory speed limit signs or may be placed at a location within the closed lane that has a reduced speed limit.

Automated Trailer Mounted Speed Limit Signs shall be delineated with retro-reflective temporary traffic control devices while in use and shall also be delineated by affixing a retro-reflective material directly on the trailer.

Upon delivery of the Automated Trailer Mounted Speed Limit Sign and before acceptance by the Authority, the Contractor shall have a representative of the manufacturer review the condition and notify the Resident in writing, of all deficiencies noted.

The Contractor shall arrange to have all necessary repairs performed at no cost to the Authority.

To avoid impairing driver vision, the Contractor shall dim the lighted speed limit readings by 50 percent during nighttime use, and restore full power lighting during daytime operation.

652.7 Method of Measurement

Automated Trailer Mounted Speed Limit Sign shall be measured for payment per each for the continued use for the duration of the project. Payment shall include the Trailer, Radar Speed Limit Sign, flashing beacon amber lights, regulatory speed limit sign, fuel, necessary maintenance, and all checking of Radar Speed Limit Signs by manufacturer and all project moves including the transporting and delivery of the unit.

652.8 Basis of Payment

The Automated Trailer Mounted Speed Limit Sign(s) will be paid for at the Contract unit price per calendar day or per each. This price shall include all costs associated with the use of the Automated Trailer Mounted Speed Limit Sign.

<u>Pay Item</u>	<u>Pay Unit</u>
652.451 Automated Trailer Mounted Speed Limit Sign	Each

Date: 2/13/2018

Element: Trailer Mounted Speed Limit.dwg

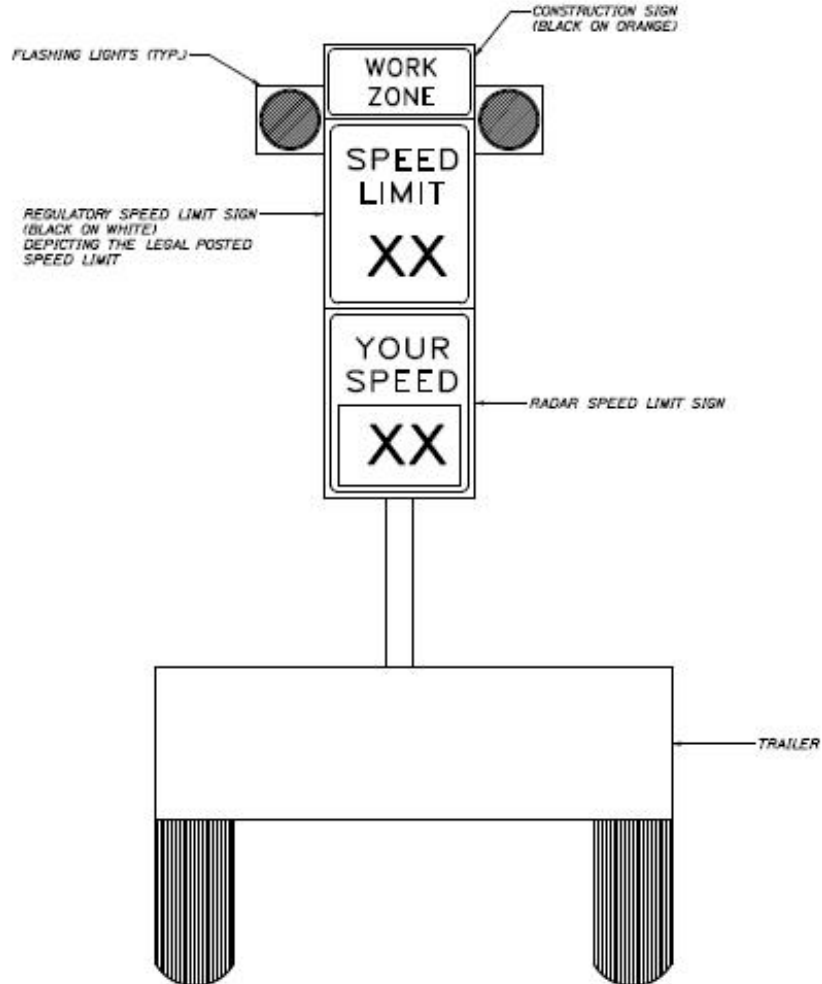

HNTB
FEBRUARY 2018

AUTOMATED TRAILER MOUNTED
SPEED LIMIT SIGN

10F.2

Date: 2/13/2018

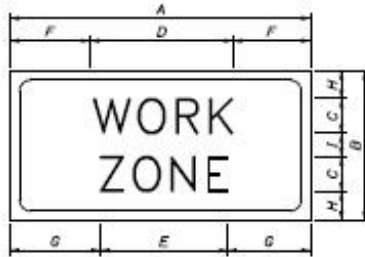

SIGN #1
 1.25" BORDER, 0.75" INDENT,
 BLACK ON ORANGE, BB GRADE PLYWOOD SIGN

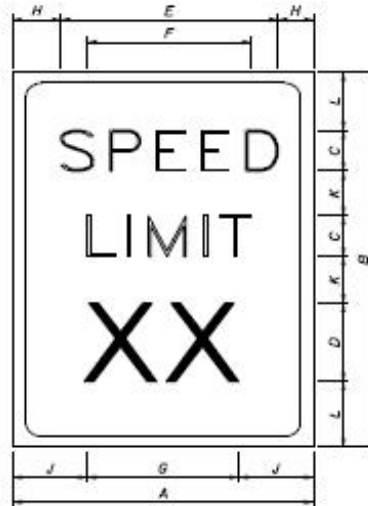

SIGN #2
 1.25" BORDER, 0.75" INDENT,
 BLACK ON WHITE, BB GRADE PLYWOOD SIGN

DIMENSIONS (INCHES) / LETTER FONTS												
	A	B	C	D	E	F	G	H	I	J	K	L
*1	48	20	50	18 1/8	16 1/8	14 1/8	15 1/8	4	2	N/A	N/A	N/A
*2	48	60	8E	16E	38 1/4	29 1/4	29 1/2	4 1/8	9 1/8	9 1/4	8	6



Filename: Trailer Mounted Speed Limit.dgn



HNTB
 FEBRUARY 2018

TRAILER MOUNTED CONSTRUCTION ZONE
 SPEED LIMIT SIGN

SPECIAL PROVISION

SECTION 652

MAINTENANCE OF TRAFFIC

(Temporary Portable Rumble Strip)

652.01 Description:

This work consists of furnishing and placing temporary portable rumble strips RoadQuake 2F TPRS or an approved equal.

652.02 Materials:

Furnish a temporary portable rumble strip system, which includes a method to transport and move these to on-site locations where they will be used. The Contractor shall submit for approval, literature and all necessary certifications to the Maine Turnpike prior to procurement of the product.

652.03 General:

If used, Temporary Portable Rumble Strips may not be practicable in areas where the roadway has more than two travel lanes, where volume windows do not allow for breaks in traffic to set up and monitor and adjust, or during night time lane closures.

Placement:

Provide rumble strips where the plans show or as directed by the Resident as follows:

Prior to placing rumble strips, clean the roadway of sand and other materials, that may cause slippage.

Place one end of the rumble strips 6 inches from the roadway centerline. Extend the strips perpendicular to the direction of travel. Ensure strips lay flat on the roadway surface.

Only one series of rumble strips, placed before the first work zone, is required per direction of travel for multiple work zones spaced 1 mile or less apart. Work zones spaced greater than 1 mile apart require a separate series of rumble strips. Each lane shall use one group of temporary rumble strips.

Bracketed "Rumble Strip Ahead" and "Bump" signs shall be utilized and will be paid for under the respective construction sign pay items.

Maintenance:

Maintain rumble strips as follows:

If rumble strips slide, become out of alignment, or are no longer in the wheel path of approaching vehicles during the work period, thoroughly clean both sides of the rumble strips and reset on a clean roadway.

Repair or replace damaged rumble strips immediately.

652.04 Method of Measurement:

The accepted quantity of temporary portable rumble strips shall be measured by the unit complete in place, per lane closure application. A unit shall consist of 1 group of 3 full-lane width of rumble strips. As shown in the plans, a maximum of 3 units may be used at each lane closure. A unit shall be measured for each group of rumble strips, each time they are used for a lane closure.

652.05 Basis of Payment:

The accepted quantity of temporary portable rumble strips will be paid for at the contract unit price per unit which shall include the transport device. Payment is full compensation for providing, relocating, maintaining or replacing, and removing temporary portable rumble strips.

If the pay item is not included in the contract quantities, then the Authority does not anticipate the use of this item on the contract. If Contractor wishes to utilize temporary portable rumble strips and the item is not in the contract, then the Contractor may propose use of them to the Authority for consideration.

<u>Pay Item</u>	<u>Pay Unit</u>
652.46 Temporary Portable Rumble Strip	Unit

SPECIAL PROVISIONSECTION 652MAINTENANCE OF TRAFFIC

(Temporary Mainline Lane Closures)
 (Lane Closure Installation and Removal Procedures)
 (Temporary Mainline Shoulder Closures)
 (Work Requiring Complete Stoppages of Traffic)
 (Short-Term or Work Hour Speed)

This Section outlines the minimum requirements that shall be maintained for working on, over, or adjacent to the Maine Turnpike roadway.

General

Three travel lanes in each direction shall be maintained at all times except while performing work in a designated lane, directly over or adjacent to traffic, during the placement and removal of traffic control devices, or otherwise specified in the Prosecution of Work and the Plans.

Temporary Mainline Lane Closures

A minimum width of 14 feet is required for all lane closures.

A lane closure is required when a danger to the traveling public may exist. The potential of any material falling onto the roadway shall be considered a potential danger. This shall include, but not necessarily be limited to, demolition debris, water, tools, equipment and materials.

A lane closure will be required whenever workers or equipment will be present within four feet of a travel lane. Trucks shall be parked at least six (6) feet from the travel lane when being loaded or unloaded. Temporary lane closures will only be allowed at the times outlined in Special Provision Section 652, Specific Project Maintenance of Traffic Requirements. These hours may be adjusted based on the traffic volume each day by the Resident.

The lane closure setup may not begin until the beginning time specified. Lane closures that are setup early or that remain in place outside of the approved period shall be subject to a lane rental fee of \$500 per five minutes for every five minutes outside of the approved time. The installation of the construction signs will be considered setting up the lane closure. Removal of the last construction sign will be considered the removal of a lane closure. Construction signs shall be installed immediately prior to the start of the lane closure and shall be promptly removed when no longer required. The installation and removal of a lane closure including signs, channelizing devices and arrow boards shall be a continuous operation. The Authority reserves the right to order removal of an approved lane closure.

The Authority desires to minimize the number of daytime lane closures and the number of times that a complete stoppage of traffic is required. The Contractor is encouraged to schedule

their work so that the interference with the flow of traffic will be minimized. Lane closures will not be allowed until traffic associated with complete stoppages of traffic has cleared. Complete stoppages of traffic or lane closures may not be allowed on a particular day if another complete stoppage of traffic has been previously approved for another project.

The following is a partial list of activities requiring lane closures. Lane closures may be required for other activities as well:

- Pavement Construction at locations specified in the Prosecution of Work and the Plans.
- Removal of trees and chips from the cleared area.
- Drainage culverts across mainline.
- Installation of temporary and permanent barrier.
- Full depth sawcut.
- Paving adjacent to active travel lane.
- Loading of trucks within four feet of a travel lane.
- Bridge Mounted, Cantilever and Overhead Sign Structure construction activities adjacent to a travel lane

Lane closures shall be removed if work requiring the lane closure is not ongoing unless included in the Contract as a long-term traffic control requirement or approved by the Resident.

The Resident is required to receive approval from the Authority for all lane closures. The request shall be submitted to the Authority by the Resident at least two (2) working days prior to the day of the requested lane closure. All requests must be received by 12:00 p.m. to be considered as received on that day. Requests received after 12:00 p.m. shall be considered as received the following day. The Contractor shall plan the work accordingly.

Lane Closure Installation and Removal Procedure

The Contractor will follow the following procedures when closing any travel lanes on the turnpike roadways:

1. The sign package shall be erected starting with the first sign and proceeding to the start of the taper. The sign crew shall erect signs with the vehicle within the outside shoulder;
2. Position the arrow board with the proper arrow at the beginning of the taper; and,
3. When arrow board is in place, continue with the drums/cones to secure the work area.

To dismantle the lane closure, start with last drums/cone placed and work in reverse order until all the drums are removed. The arrow board which was installed first shall be the final traffic control device removed, excluding the sign package. The remaining sign package shall be picked up starting with the first sign placed and continuing in the direction of traffic and with the vehicle in the outside shoulder.

Temporary Mainline Shoulder Closures

Temporary mainline shoulder closures will only be allowed as outlined in Special Provision Section 652, Specific Project Maintenance of Traffic Requirements. Temporary shoulder closures are anticipated at locations where Contractor access to the mainline is required.

Temporary shoulder closures with plastic drums shall be removed at the end of the workday. Temporary shoulder closures with plastic drums will not be allowed during periods of inclement weather as determined by the Authority.

Work Requiring Complete Stoppages of Traffic

Complete stoppages of traffic will only be allowed as outlined in Special Provision Section 652, Specific Project Maintenance of Traffic Requirements, or as approved by the Resident.

The following is a partial list of activities requiring complete stoppages of traffic. Complete stoppages of traffic may be required for other activities as well:

- Moving of heavy or slow equipment across or on the travel lanes (stoppage less than five minutes).
- Erection or removal of overhead or cantilever sign structures and bridge mounted signs (stoppage less than 25 minutes).
- Blasting of Ledge (Stoppage time 8 minutes).

The maximum time for which traffic may be stopped for blasting at any single time shall be eight (8) minutes. The duration shall be measured as the time between the time the last car passes the Resident until the time the Resident determines that all travel lanes are cleared of blast debris. If, due to the throw of rock onto the highway or other blasting related activities, traffic is stopped for more than eight minutes, the Contractor shall pay a penalty of \$500.00 per minute for every minute traffic is stopped in each roadway (northbound or southbound), in excess of the eight minutes limit. Total penalty shall be deducted from the next pay estimate.

State Police will be used to stop traffic. Cost for State Police will be the responsibility of the Authority. The times requested for trooper assisted equipment moves by on-duty troopers cannot be guaranteed. The MTA will not be held responsible for any delays or costs associated with the delay, postponement or cancellation of an on-duty trooper assisted equipment move.

The Erection or Removal of Structural Steel/ Space Frames/ Overhead Signs

The erection or removal of structural steel, overhead signs, and space frames will only be allowed at times outlined in Section 652, Specific Project Maintenance or Traffic Requirements. Traffic shall be stopped and may be held for periods of up to 25 minutes during these operations. Before the roadway is reopened, all materials shall be secured so they will not endanger traffic passing underneath.

The Contractor will reimburse the Authority at the rate of \$2,500.00 per five-minute period for each roadway (northbound and southbound), in excess of the 25 minute limit. Total penalty shall be deducted from the next pay estimate.

Equipment Moves

The complete stoppage of traffic for an equipment move (including delivery of materials to the median) will be considered for approval if the action cannot reasonably be completed with the erection of a lane closure. Contractor shall be responsible for the installation of Signs CS-3, "Expect Stopped Traffic" and Signs W3-4 "Be Prepared to Stop", in accordance with the Single Lane Closure Detail immediately prior to the equipment move. These signs shall be covered when not applicable.

The maximum time for which traffic may be stopped and held for an equipment move at any single time shall be five (5) minutes. The duration shall be measured as the time between the time the last car passes the Resident until the time the Resident determines that all travel lanes are clear. The traffic shall only be stopped for the minimum period of time required to complete the approved activity. The Contractor shall reimburse the Authority at a rate of \$500 per minute for each minute in excess of the five-minute allowance. Total penalty shall be deducted from the next pay estimate.

Unapproved movement of heavy equipment across the travel lanes shall be considered a violation of the Maintenance of Traffic Requirements and is subject to the fines of \$500 per minute or portion thereof.

Request for Complete Stoppage of Traffic

A request for a complete stoppage of traffic must be submitted to the Resident for approval. The Resident is required to receive approval from the Authority for all stoppages. The request shall be submitted to the Authority by the Resident at least five working days prior to the day of the requested stoppage of traffic and two days for a stoppage less than five minutes. All requests must be received by 12:00 p.m. noon to be considered as received on that day. Requests received after 12:00 p.m. shall be considered as received the following day. The Contractor shall plan the work accordingly.

Short-Term or Work Hour Speed

A short-term or work hour speed (Fines Doubled) is a regulatory speed limit that indicates the maximum legal speed through a work zone which is lower than the normal posted speed. The speed limit shall be displayed by black on white speed limit signs in conjunction with a black on orange "Work Zone" plate. Speed limit signs shall be installed at each mile within the work zone. The reduced speed zone shall be at least 1,500 feet long. Any existing regulatory speed limit signs within the reduced speed zone shall be covered once the reduced speed signs have been erected.

Two orange fluorescent flags shall be attached to all speed limit signs that are uncovered for a period of time exceeding one week. This work shall be incidental. Signs that are uncovered on a regular basis are not required to have the supplemental flags.

The reduced speed limit signs shall only be used during the following circumstances unless approved by the Resident:

- Workers are adjacent to traffic
- Travel lane is closed

The signs shall be covered or removed when not applicable. The covering and uncovering of signs shall be included for payment under Maintenance of Traffic. Signs relating to reduced speed shall be installed in accordance with the details. The Contractor shall note that signs installed behind concrete barrier in the outside shoulder are required to be clearly visible to all drivers at all times.

Temporary toll plaza lane closures may be required for lanes not designated for long term closure on the Maintenance of Traffic Control Plans. The following minimum requirements shall be maintained:

Plaza lanes shall remain available for opening at all times except when the Contractor is performing work in or near toll lanes such that appropriate access to the lane entry or departure is constrained by Contractor activities, or adjacent to or directly over the plaza lanes. A plaza lane closure is required when danger to the traveling public, other MTA contractors or MTA employees may exist. The potential of any material falling onto the roadway shall be considered a potential danger. This shall include, but not necessarily be limited to, demolition debris, water, tools, equipment and material.

A plaza lane closure will be required whenever workers or equipment will be present in a plaza lane or when regular vehicular access into or out of a toll lane is impeded by the Contractor. The Authority may also require adjacent lanes to be closed to protect the traveling public or Authority employees. Temporary plaza lane closures are allowed from 07:00 pm to 05:00 am. These hours may be adjusted by the Resident based on the daily traffic volumes. Plaza lane closures not completely removed by the time specified will be subject to a rental fee of \$100.00 per 10 minutes for every 10 minute increment beyond the specified ending time for each lane. Temporary plaza lane closures will not be allowed during periods of inclement weather as determined by the Authority and will not be allowed on Saturday, Sundays, and Holidays. The Authority reserves the right to order removal of approved temporary plaza lane closures.

Requests for temporary traffic lane closures shall be submitted to the Resident for approval. The Resident is required to receive approval from the Maine Turnpike Authority's Plaza Supervisor for all plaza lane closures. The request shall be submitted to the Plaza Supervisor by the Resident at least one working week prior to the day of the requested plaza lane closure. All requests must be received by 12:00 p.m. noon to be considered as received on that day. Requests received after 12:00 p.m. shall be considered as received the following day. The Contractor shall plan the work accordingly.

SPECIAL PROVISIONSECTION 652MAINTENANCE OF TRAFFIC

(Temporary Barrier)

652.1 Description

The following paragraphs are added:

The Contractor shall furnish, install and maintain temporary barriers proposed for use on the project shall receive the approval of the Resident Engineer a minimum of six weeks prior to installing the attenuators and barriers on the project.

Paragraph 652.2.1 Truck Mounted Attenuator shall be removed and replace with the following:

652.2.1 Temporary Impact Attenuator and Barrier.

Temporary traffic barrier shall be one of the barriers included under FHWA's Roadside Hardware Policy and Guidance for crashworthy longitudinal barriers, at the Contractor's discretion, unless otherwise specified. The type of temporary traffic barrier shall be provided to the Engineer prior to use. All temporary traffic barrier and corresponding connections shall meet, unless otherwise specified in the Plans, Test Level 3 (TL-3) criteria as defined in NCHRP Report 350 or the AASHTO Manual for Assessing Safety Hardware (MASH). The appropriate resource shall be determined as described in the MASH publication.

The Contractor shall supply the FHWA approval letter, manufacturer approved shop drawings and connection and anchorage details (if applicable) and catalogue cuts for each barrier type to the resident engineer for approval. The manufacture's shop drawings shall specify the maximum deflection distance the product is approved for. The Contractor's shop drawing submittal shall specify the available distance between the back or non-roadway side of the barrier to the closet fixed object or edge of open excavation being protected for each location of differing available deflection distance.

652.3.7 Operations

Each run of temporary barrier units shall be fastened together to form a continuous chain. Temporary impact attenuators with delineation shall be installed at the ends of the barrier within 30 feet of approaching traffic. The Contractor shall not leave a barrier leading edge unprotected. Delineators shall be installed in conformance with the manufacturer's recommendations on the barriers at the termini at 20 foot intervals on tangent sections and 10 foot intervals on curved sections depending on the radius as determined by the Resident Engineer. Delineators mounted on top of the barrier separating opposing traffic shall have two-sided amber reflectors delineating the left edge.

Temporary Barriers shall be removed and reset from existing locations and reset in accordance with the above requirements and manufacture’s recommendations, as directed by the Resident Engineer.

Temporary Barrier requiring pinning to the asphalt pavement per manufacturer’s recommendations shall not be used on the final pavement wearing surface.

652.7 Method of Measurement

The following sentence is added:

Temporary Barrier will be measured by the lump sum.

652.8.2 Basis of Payment

The following paragraphs are added:

Temporary Barrier will be paid for at the Contract lump sum price, complete in place. Such payment shall be full compensation for setting, resetting, temporary storage, removing, transporting and stacking at the area designated, furnishing all materials and all other incidentals necessary to complete the work.

Payment of the Temporary Barrier shall be based on a percentage of the work accomplished during that pay period.

Payment will be made under:

<u>Pay Item</u>	<u>Pay Unit</u>
652.50 Temporary Barrier	Lump Sum

SPECIAL PROVISION

SECTION 652

MAINTENANCE OF TRAFFIC

(Temporary Stormwater Drainage)

Section 652 of the Maine Turnpike Authority 2016 Supplemental Specifications is modified as follows:

652.1 Description

The following paragraph is added:

The work shall also consist of furnishing, installing, maintaining and removing temporary stormwater drainage structures, pipe, and systems necessary to provide continual drainage of the travel ways and construction areas during the Contractors execution of the work.

652.2 Materials

The following paragraph is added:

Materials and Construction Requirements shall be per the Section 603 – Pipe Culverts and Stormdrain and Section 604 – Manholes, Inlets and Catch Basins, and other referenced or appropriate section(s) of the Contract.

652.2.3 Responsibility of the Contractor

The following paragraph are added:

The Contractor shall provide the necessary stormwater drainage for temporary control of stormwater during construction, including, but not limited to, catch basins, manholes, pipe, outlet structures, and other means that is appropriate to the construction means, methods and sequencing of construction selected by the Contractor.

Temporary stormwater drainage shall be provided to keep the active travelways and shoulders free from ponding water at low points and flowing stormwater along an embankment, gutter, curb, temporary barrier, or other impediment for proper evacuation of stormwater runoff.

Should the temporary stormwater drainage employed by the Contractor fail to protect the travelways and shoulders from stormwater runoff as determined by the Resident, or at the request of the Resident, the Contractor shall employ additional measures to control stormwater runoff.

652.7 Method of Measurement

The following paragraph is added:

Temporary Stormwater Drainage will not be measured separately for payment, but shall be incidental to the related Contract items.

652.8.2 Basis of Payment

There shall be no separate payment for Temporary Stormwater Drainage.

SPECIAL PROVISION

SECTION 655

ELECTRICAL WORK

655.01 Description

All work shall be governed by the Standard Specifications except for that work which applies to those sections of the Standard Specifications which are amended by the following modifications, additions and deletions.

Specifically, for the electrical work (in addition to standards specified in individual work sections), the following standards are imposed, as applicable to the work in each instance:

- NEC, National Electrical Code (NFPA No. 70)
- NFPA No. 101, Life Safety Code
- ANSI C 2, National Electrical Safety Code
- ANSI C 73, Dimensions of Attachment Plugs and Receptacles
- NECA standards for installation
- NEMA standards for materials and products
- UL, Underwriters Laboratories

The Contractor will warranty the material supplied by them and their workmanship for a minimum of one (1) year from completion of the project.

655.02 General Provisions

RELATED DOCUMENTS

General provisions of this Contract, including General Provisions and Special Provisions, apply to work of this section.

SUMMARY

This Section specifies several categories of provisions for electrical work, including:

1. Certain adaptive expansions of requirements specified in the Special Provisions.
2. General performance requirements within the electrical systems as a whole.
3. General work to be performed as electrical work, because of its close association.

SUMMARY OF ELECTRICAL WORK

General Outline: The facilities and systems of the electrical work can be described (but not by way of limitation) as follows:

1. Installation of electrical control and power distribution systems, including the electrical connections to new equipment.
2. Installation of toll revenue collection systems hardware.
3. Installation of temporary and interim provisions.

Permits and Fees: This work shall include the procurement of and payment for any and all permits and fees required for the performance of the electrical work including those that may be required from local utilities for services.

COORDINATION OF ELECTRICAL WORK

Refer to Part II, Special Provisions for general coordination requirements applicable to the entire work. It is recognized that the Contract documents are often diagrammatic in showing certain physical relationships, which shall be established within the electrical work, and in its interface with other work including utilities and mechanical work, and that such establishment is the exclusive responsibility of the Contractor.

Arrange electrical work in a neat, well organized manner with conduit and similar services running parallel with primary lines of the building construction, and with a minimum of 7'0" overhead clearance where physical limitations permit.

Locate operating and control equipment properly and in accordance with the NEC, to provide easy access, and arrange entire electrical work with adequate access for operation and maintenance.

Coordination of Options and Substitutions: Where the Contract documents permit the selection from several product options, and where it becomes necessary to authorize a substitution, the Contractor shall not proceed with purchases until coordination of all interface requirements has been checked and satisfactorily established. Substitutions are subject to approval by the Authority or designated representative per the requirements of the Contract documents.

SUBMITTALS FOR ELECTRICAL WORK

For electrical work, submittals are required for each category of items listed below.

- Shop Drawings, Product Data, Certifications, Test Reports, Warranties, Guarantees, Installation Drawings, and Work Checklist in Appendix D.
- Installation Drawings shall be modified and submitted to reflect any changes during installation of electrical equipment.

The Contractor, prior to forwarding shop drawings and product data to the Resident, shall check all conditions, make all corrections and sign and date each set. No shop drawings will be reviewed by the Resident without the signature of the Contractor, which shall signify that he has checked the submittals.

PRODUCTS, ELECTRICAL WORK

Refer to Divisions 600 and 700 of the Standard Specifications for general requirements on products, materials and equipment. The following provisions expand or modify the requirements as applicable to electrical work:

Compatibility: Provide products, which are compatible with other products of the electrical work and with other work requiring interface with the electrical work, including electrical connections and control devices. For exposed electrical work, coordinate colors and finishes with other work.

FLOOR AND WALL PENETRATIONS

Where electrical materials penetrate walls or floors that are a part of a fire separation or assembly, the opening shall be effectively sealed to maintain separation integrity. Openings shall be closed using General Electric RTV850 Silicone RTV Foam, or approved equal to form a fire rated, water-tight seal, and installation with automatic mixing only. The penetration seal materials shall pass ASTM E 814 (UL 1479) Standard Method of Fire Tests for Through Penetration Fire Stops up to the required fire resistance.

Where conduits penetrate a wall, floor or ceiling that is part of a weatherproof barrier, a non-shrink weatherproof type grout and or Sika 1A caulking shall be used, in accordance with manufacturer's installation instructions.

All work, materials, labor to fireproof or waterproof conduit penetrations shall be incidental to the various pay items

EXCAVATING FOR ELECTRICAL WORK

The work of this article is defined to include whatever excavating and back-filling is necessary to install the electrical work. Coordinate the work with other excavating and back-filling in the same area, including de-watering; flood protection provisions, and other temporary facilities. Coordinate the work with other work in the same area, including other underground services (existing and new), paving, and concrete work. Coordinate with weather conditions and provide temporary facilities needed for protection and proper performance of installations, excavating and back-filling.

General Standards: Except as otherwise required, comply with the applicable provisions of Divisions 600 and 700 of the Standard Specifications for information related to electrical-work excavating and back-filling. Refer instances of uncertain applicability to the Resident for resolution before proceeding.

ELECTRICAL WORK CLOSEOUT

Construction Equipment: After completion of performance testing and the Authority's performance testing, remove Contractor's tools, test facilities, construction equipment and similar devices and materials used in execution of the work but not incorporated in the work.

ELECTRICAL SYSTEM TEST

The Contractor shall submit certification of the adequacy of each power and/or communications circuit for the following sub-systems, where applicable:

- ORT Lane Controller Cabinets
- Cash Lane Controller (LC) System
- Automatic Vehicle Identification (AVI) Readers
- Automatic Vehicle Identification (AVI) Antennas
- Digital Video Audit System (DVAS)
- Traffic Control Pedestal (TCP)
- Violation Enforcement System (VES)
- Vehicle Capture and Recognition System (VCARS)
- Canopy Override Switch (COS)
- Manual Lane Terminal (MLT)
- Receipt Printer (RP)
- OPUS

Verification of the electrical system should be done by turning on/off assigned circuit breakers prior to attachment of equipment to validate panel schedule and that proper voltage is present at termination.

COMMUNICATIONS SYSTEMS

Provide outlets, wireways, device plates, etc., in conformance with the applicable sections of this specification, as may be required.

Wireways shall be in accordance with "Wireways" part of the Technical Specifications and NEC and the following special conditions:

- Minimum size shall be 1-inch unless otherwise noted.
- No more than two standard factory 90-degree bends per 100 feet or three 90 degree 24-inch radius bends and as to adhere to minimum manufacturers bend radius's on data cables.

655.03 Electrical Wireways

RELATED DOCUMENTS

General provisions of the Contract, including General Provisions and Special provisions, apply to work of this section.

SUMMARY

The requirements of this section apply to electrical wireway work specified elsewhere in these Specifications.

The types of electrical wireways required for the project may include the following:

- Electrical metallic tubing.
- Intermediate metal conduit.
- Liquid tight metallic flexible conduit.
- Galvanized rigid metal conduit.
- Nonmetallic conduit. (PVC)
- Surface metal wireways or Non-metallic wireway.

QUALITY ASSURANCE

Manufacturers: Firms regularly engaged in manufacture of electrical wireways of types and capacities required, whose products have been in satisfactory use in similar service for not less than three years.

Contractor: A firm with at least three years of successful installation experience on projects with electrical wiring installation work similar to that required for the project. Under this definition, Contractor can also be a subcontractor to the General Contractor for the Project.

NEMA Compliance: Comply with applicable portions of National Electrical Manufacturers Association standards pertaining to nonmetallic duct and fittings for underground installation.

UL Labels: Provide electrical wireways, which have been listed and labeled by Underwriters Laboratories.

NEC Compliance: Comply with National Electrical Code (NFPA No. 70) as applicable to construction and installation of electrical wireways.

PRODUCT DELIVERY, STORAGE AND HANDLING

Provide color-coded end-cap thread protectors on exposed threads of threaded metal conduit. Handle conduit and tubing carefully to prevent bending and end-damage and to avoid scoring finish. Store pipe and tubing inside and protect from weather. When necessary to store outdoors, elevate well above grade and enclose with durable, watertight wrapping.

MATERIALS AND COMPONENTS

For each electrical wireway system required, provide a complete assembly of conduit or tubing with fittings including, but not necessarily limited to, connectors, nipples, couplings, elbows, expansion fittings, supports, and other components and accessories as needed to form a complete system of type required.

Metal Conduit, Tubing and Fittings: Provide metal conduit, tubing and fittings of type, grade, size and weight (wall thickness) required for each service. Where type and grade are not indicated, provide proper selection determined to fulfill wiring requirements, and comply with National Electrical Code for electrical wireways.

Rigid Steel Conduit: FS WW-C-581 and ANSI C80.1.

Intermediate Steel Conduit: FS WW-C-581 and ANSI C80.1.

EMT- Electrical Metallic Tubing: FS WW-C-563A, ANSI C80.3 and UL 797. Installation shall comply with NEC Article 348. Provide high quality, hot dip galvanized, electrical metallic tubing conduit and fittings of type, size and weight (wall thickness) required for each application. EMT shall only be used in enclosed areas that are not subject to possible collision or interference. Where type and grade are not indicated, provide proper selection determined to fulfill wiring requirements, and comply with National Electrical Code. Rain-tight compression type connectors shall be used in all cases. Set-screw type conduit connections or fittings shall not be used.

Galvanized Rigid Metal Conduit Fittings: FS W-F-408, Type and Classes as required.

Liquid-tight Flexible Metal Conduit: Provide liquid-tight flexible metal conduit comprised of single strip, continuous, flexible interlocked, double-wrapped steel, galvanized inside and outside; forming smooth internal wiring channel; with liquid-tight jacket of flexible polyvinyl chloride (PVC).

Liquid-tight Flexible Metal Conduit Fittings: FS W-F-406, Type as required.

Nonmetallic Conduit and Fittings (PVC): Provide nonmetallic conduit and fittings of type, size and weight (wall thickness) required for each service. Where type and grade are not indicated, provide proper selection determined to fulfill wiring requirements, and comply with National Electrical Code for electrical wireways, and with type selected in accordance with applicable standards.

Metallic or Nonmetallic (PVC) Surface Mounted Wireways: Provide wireways for surface mounting as required. Wireways shall be of rectangular cross section of size as required by the National Electrical Code (NFPA No. 70) for conductor fill. Wireways shall be of a design to accommodate wiring devices required. All wireway fittings shall manufacture provided and not field fabricated.

Conduit and Tubing and Wireway Accessories: Provide conduit, tubing and wireway accessories including straps, hangers, angles expansion and deflection fittings as recommended by conduit, tubing and wireway manufacturers.

Mounting strut materials and hardware: Provide corrosion-resistant hot-dip galvanized strut members and stainless steel hardware for all equipment and cabinet mounting applications.

INSTALLATION

Install conduit and tubing products as required, in accordance with manufacturer's written instructions, applicable requirements of NEC and National Electrical Contractors Association's "Standard of Installation", and in accordance with recognized industry practices to ensure that products serve intended function.

Complete the installation of electrical wireways before starting installation of cables within wireways.

Where conduit is installed in earth, it shall be Polyvinyl Chloride (PVC) conduit as specified in the Plans.

PVC conduit shall be used in concrete slabs on grade and where noted in the Plans. Metallic conduit is not permitted in the concrete slabs or in substitution of any PVC conduit locations specified on the Plans without specific authorization by the Authority.

Wherever possible, install horizontal wireway runs above water and steam piping.

Install surface metal wireways and accessories as required on elevations. Carefully coordinate with interior finishes and furnishings.

At any point where a conduit crosses an expansion joint, or where movement between adjacent sections of conduit can be expected, bronze or alloy expansion fittings shall be installed equal to Type AX as made by the O.Z. Electrical Manufacturing Co., Inc., or equivalent by Hope or Spring City unless such locations are within conduit specified as non-metallic. Such locations shall be handled with a non-metallic equivalent or as specified in Plans.

The Contractor shall submit a proposed method of attaching all ancillary components to the space frame to the Resident for approval. The proposed attachment method shall not require drilling, welding or other attachment methods that will damage the space frame or its galvanized coating. Any areas of galvanized coating that are damaged by the Contractor during installation of ancillary components shall be repaired in accordance with ASTM A780.

655.04 Wires and Connectors

RELATED DOCUMENTS

The general provisions of the Contract, including General Provisions and Special Provisions, apply to the work specified in this section.

SUMMARY

The requirements of this section apply to the wire work specified elsewhere in these Specifications.

The applications for wire and connectors required on the project may include the following:

- Power distribution circuitry.
- Lighting circuitry.
- Appliance and equipment circuitry.

QUALITY ASSURANCE

Manufacturers: Firms regularly engaged in the manufacture of electrical products of the types and ratings required, whose products have been in satisfactory use in similar service for not less than 3 years.

Contractor: A firm with at least three years of successful installation experience on projects with electrical wiring installation work similar to that required for the project. Under this definition, Contractor can also be a subcontractor to the General Contractor for the Project.

NEC Compliance: Comply with National Electrical Code (NFPA 70) as applicable to construction and installation of electrical cable, wire and connectors.

UL Labels: Provide electrical cable, wire and connectors, which have been listed and labeled by Underwriters Laboratories.

NEMA/ICEA Compliance: Comply with National Electrical Manufacturers Association/Insulated Power Cable Authorities Association Standards publications pertaining to materials, construction and testing wire cable, where applicable.

PRODUCT DELIVERY, STORAGE AND HANDLING

Provide factory-wrapped water-proof flexible barrier material for covering wire and cable on wood reels, where applicable; and weather resistant fiberboard containers for factory-packaging of cable, wire and connectors, to protect against physical damage in transit. Do not install damaged cable, wire or connectors; remove from project site.

Store wire and connectors in factory-installed coverings in a clean, dry indoor space which provides protection against the weather.

MANUFACTURERS

Provide products produced by one of the following or approved equal (for each type of cable, wire and connectors):

Cable and Wire:

- Anaconda Wire and Cable Co.
- Belden Corp.
- General Cable Corp.
- Phelps Dodge Cable and Wire Co.
- Wire and Cable Dept., General Electric Co.
- Rome Cable Corp.

Connectors:

- AMP Inc.
- Burndy Corp.
- Minnesota Mining and Mfg. Co.
- OZ/Gedney Co.
- Thomas & Betts Co.

WIRE AND CONNECTORS

Except as otherwise required, provide wire and connectors of manufacturer's standard materials, as required by published product information; designed and constructed as recommended by the manufacturer, and as required for the installation.

Wire: Provide factory-fabricated wire of the size, rating, material and type as required for each service. Where not indicated, provide proper selection as determined by Installer to comply with installation requirements and with NEC standards. Select from only the following types, materials, conductor configurations, insulations, and coverings for 120/208 Volt circuits for a 3-phase system:

UL Type: THW. (Sizes #6 AWG wire and larger)

UL Type: THHW. (Sizes up to #4 AWG wire)

UL Type: USE. (Underground installation)

Material: Copper.

Conductors: (AWG wire 20 to AWG wire 16).

Note: All low voltage signal conductors (including CAT5e and CAT6 data cables) shall be solid not stranded wire. Conductors for underground, below grade, or in conduit to lane devices shall be OSP grade, gel filled. Interior building communications cables may be plenum rated for interior wall or cable tray applications.

Concentric-lay-stranded (standard flexibility) (AWG wire 14 and larger).

Interconnection for data communication shall be performed with cables that shall be submitted for approval. The general cable types are designated on the Plans/ Specifications. Minimum bend radius should meet the requirements of the manufacturer and the requirements of the system.

Wire shall be color-coded as noted in the wiring schedules provided in the Plans.

Lead-in cables to extend loop detectors shall be IMSA Type 50-2. Loop lead-in cables shall be manufactured with a size of #14 AWG.

Klik-Its (Power & Tel Enterprise Part #C8820) shall be used at all loop wire splice locations. All splices must be twisted, soldered and shrink-wrap waterproofed before enclosure is placed.

Home run cables preferably should not be shielded. The use of shielded cable is acceptable provided neither end is grounded.

All cable labeling shall be coordinated with the requirements of the Authority's Toll System Integrator (SI).

INSTALLATION

Install electrical wire and connectors as required, in accordance with the manufacturer's written instructions, the applicable requirements of NEC and the National Electrical Contractors Association's "Standard of Installation", and in accordance with recognized industry practices to ensure that products serve the intended functions.

Coordinate cable and wire installation work with electrical wireway and equipment installation work, as necessary for proper interface.

All wire and cable shall be in first class condition when they are installed. Lo-leak lubricants manufactured for the purpose of a pulling lubricant may be used when necessary.

All wires shall be continuous from outlet and there shall be no unnecessary slack in the conductors.

All wire and cable shall be marked and labeled at terminus ends and splice points.

FIELD QUALITY CONTROL

Prior to energizing, check wire for continuity of circuitry and for short circuits with ohmmeter type testing equipment, and Meggar test to check insulation resistance. Correct malfunction when detected.

Subsequent to wire hook-ups, energize circuitry and demonstrate functioning in accordance with requirements.

655.05 Electrical Boxes and Fittings

RELATED DOCUMENTS

The general provisions of the Contract, including General Provisions and Special Provisions, apply to the work specified in this section.

SUMMARY

The types of electrical boxes and fittings required for the project may include the following:

- NEMA 4X Cabinet for ORT AVI Readers
- Outlet boxes
- Junction boxes
- Pull boxes

- Floor boxes
- Conduit bodies
- Bushings
- Locknuts

QUALITY ASSURANCE

Manufacturers: Firms regularly engaged in the manufacture of electrical units of types and sizes required, whose products have been in satisfactory use in similar service for not less than three years.

Contractor: A firm with at least three years of successful installation experience on projects with electrical installation work similar to that required for the project. Under this definition, Contractor can also be a subcontractor to the General Contractor for the Project.

NEC Compliance: Comply with National Electrical Code (NFPA 70) as applicable to construction and installation of electrical boxes and fittings.

U.L. Labels: Provide boxes and fittings, which have been listed and labeled by Underwriters Laboratories.

NEMA Compliance: Comply with National Electrical Manufacturers Association standards as applicable to nonmetallic fittings for underground installation.

NECA Standard: Comply with applicable portions of the National Electrical Contractors Association's "Standard of Installation".

MANUFACTURERS

Provide products produced by one of the following or approved equal (for each type of box and fitting):

ORT Control Cabinet:

- Hammond Manufacturing (provided by SI and installed by the Contractor)

Interior Outlet Boxes:

- Appleton Electric Co.
- Arrow Conduit and Fittings Corp.
- National Electric Products Co.
- OZ/Gedney Co.
- Steel City, Midland-Ross Corp.

Junction and Pull Boxes:

- Arrow-Hart, Inc.
- General Electric Co.
- OZ/Gedney Co.
- Square D Co.
- Unitil

Conduit Bodies:

- Appleton Electric Co.
- Crouse-Hinds Co.
- Killark Electric Mfg. Co.
- Pyle-National Co.

Bushings, Knockout Closures and Locknuts:

- Allen-Stevens Conduit Fittings Corp.
- Allied Metal Stamping, Inc.
- Appleton Electric Co.
- Carr Co.
- Raco, Inc.
- Steel City, Midland-Ross Corp.
- Thomas and Betts Co., Inc.

MATERIALS

ORT Control cabinet: shall be provided by the Authority's Toll System Integrator (SI) and installed by the Contractor. The following information is provided to assist the Contractor with planning for the associated conduit and wiring work. The ORT Control Cabinet shall have dimensions of:

Height 6'-0"
 Width 12'-0"
 Depth 3'-0"

FABRICATED MATERIALS

Interior Outlet Boxes: Provide galvanized steel interior outlet wiring boxes, of the type, shape and size, including depth of box, to suit each respective location and installation; constructed with stamped knockouts in back and sides, and with threaded holes with screws for securing box covers or wiring devices.

Interior Outlet Box Accessories: Provide outlet box accessories as required for each installation, including mounting brackets, wallboard hangers, extension rings, fixture studs, cable clamps and metal straps for supporting outlet boxes, compatible with outlet boxes being used and meeting requirements of individual wiring situations. Choice of accessories is Installer's option. All covers for outlet boxes to be stainless steel.

Junction and Pull Boxes: Provide galvanized sheet steel, PVC or concrete junction and pull boxes as called for in the Plans with screw-on covers; of the type shape and size, to suit each respective location and installation; with welded seams and equipped with stainless steel nuts, bolts, screws and washers.

Conduit Bodies: Provide galvanized cast-metal conduit bodies, of the type, shape and size, to suit each respective location and installation, constructed with threaded conduit ends, removable cover, and corrosion-resistant screws.

Bushings, Knockout Closures and Locknuts: Provide corrosion-resistant punched-steel box knockout closures, conduit locknuts and malleable iron conduit bushings of the type and size to suit each respective use and installation.

Mounting strut materials and hardware: Provide corrosion-resistant hot dipped galvanized members and stainless steel hardware for all equipment mounting applications. Where strut material is exposed to the weather, and less than 10 feet off the ground, struts shall be stainless steel. When any galvanized strut member or hardware is cut or the galvanizing is compromised, the affected area shall be wire brushed and cleaned to bare metal and the area shall be given two coats of cold galvanizing (following application instructions).

INSTALLATION OF BOXES AND FITTINGS

Install all equipment cabinets in compliance with NEC requirements, in accordance with the manufacturer's written instructions and with recognized industry practices to ensure the boxes and fittings serve the intended purposes. Contractor shall coordinate all associated conduit, wiring and related work with the Resident and SI to confirm appropriate placement in coordination with ORT Control cabinet installation. Given the final installation of the ORT Control cabinets will likely take place several weeks following the placement of the cabinets in the plaza tunnel, the Contractor shall work with the Resident to provide adequate protection of the cabinets until they are mounted in their final location.

Install electrical boxes and fittings in compliance with NEC requirements, in accordance with the manufacturer's written instructions and with recognized industry practices to ensure that the boxes and fittings serve the intended purposes:

Provide weatherproof outlets for interior and exterior locations exposed to weather or moisture.

Provide knockout closures to cap unused knockout holes where blanks have been removed.

Locate boxes and conduit bodies to ensure accessibility of electrical wiring.

All boxes shall be rigidly secured in position unless otherwise directed

Where standard boxes are not suitable, provide boxes of special design to suit space and function.

The Contractor shall submit a proposed method of attaching all ancillary components to the space frame to the Resident for approval. The proposed attachment method shall not require drilling, welding or other attachment methods that will damage the space frame or its galvanized coating. Any areas of galvanized coating that are damaged by the Contractor during installation of ancillary components shall be repaired in accordance with ASTM A780.

655.06 Wiring DevicesRELATED DOCUMENTS

The general provisions of the Contract, including General Provisions and Special Provisions, apply to the work specified in this section.

SUMMARY

Wiring devices are defined as single discrete units of electrical distribution systems, which are intended to carry but not utilize electric energy.

The types of electrical wiring devices required for this project include the following:

- Receptacles
- Switches
- Wall plates
- Plugs
- Connectors
- Breakers

QUALITY ASSURANCE

Manufacturers: Firms regularly engaged in manufacture of wiring devices, of types and ratings required, whose products have been in satisfactory use in similar service for not less than three years.

Contractor: A firm with at least three years of successful installation experience on projects with electrical installation work similar to that required for the project.

NEC Compliance: Comply with National Electrical Code (NFPA No. 70) as applicable to construction and installation of electrical wiring devices.

UL Labels: Provide electrical wiring devices, which have been tested, listed and labeled by Underwriters Laboratories.

NEMA Compliance: Comply with National Electrical Manufacturers Association standards for general- and specific-purpose wiring devices.

MANUFACTURERS

Provide products produced by one of the following:

- Arrow-Hart, Inc.
- Bell Electric Co.
- Bryant Electric Co.
- Crouse-Hinds Co.
- Cutler-Hammer, Inc.
- General Electric Co.

- Gould, Inc.
- Harvey Hubbell Inc.
- Pass and Seymour, Inc.
- Slater Electric, Inc.
- Square D Co.
- Hunt Electronics
- Lutron
- Intermatic
- Paragon
- Unitil

FABRICATED DEVICES

Provide factory-fabricated wiring devices, in type and electrical rating for the service required.

Receptacles: Comply with NEMA Stds. Pub. No. WD1 and as follows:

General-Duty Duplex: Provide duplex general-duty type, spec. grade, receptacles, 2-pole, 3-wire grounding, with green hexagonal equipment ground screw, ground terminals and poles internally connected to mounting yoke, 15-ampere, 125-volts, with metal plaster ears, screw terminal connectors, NEMA configuration 5-15R unless otherwise required.

Heavy-Duty Duplex: Provide duplex type, spec. grade, receptacles, 2-pole, 3-wire grounding, with green hexagonal equipment ground screw, 30-ampere, 125-volts, with metal plaster ears, screw terminal connectors, NEMA configuration L5-30R unless otherwise required. Provide L5-30R twist lock outlets as required for the UPS connections.

Switches: Comply with NEMA Stds. Pub. No. WD1 and as follows:

Provide general-duty flush toggle switches, 20-ampere, 120/277 VAC, with mounting yoke insulated from mechanism, equipped with plaster ears, and side-wired screw terminals as follows:

Single pole switches	Double pole switches
Three Way switches	Four Way switches

Breakers: Breakers shall be compatible with panel circuits. All breakers necessary will be incidental to the Contract pay items.

WIRING DEVICE ACCESSORIES

Wall Plates: Provide single switch and duplex outlet wall plates for wiring devices, with ganging and cutouts as required, provide with metal screws for securing plates to devices, screw heads colored to match finish of plate, and wall plates possessing the following additional construction features:

Material and Finish: 0.04-inch thick, satin finished stainless steel.

INSTALLATION OF WIRING DEVICES

Install wiring devices where required, in accordance with manufacturer's written instructions, applicable requirements of NEC and National Electrical Contractors Association's "Standard of Installation", and in accordance with recognized industry practices to ensure that products serve intended function.

Delay installation of devices until wiring is completed.

Install receptacles and switches only in electrical boxes that are clean and free from excess building materials, debris, etc.

PROTECTION OF WALL PLATES AND RECEPTACLES

Upon installation of wall plates and receptacles, Contractor shall use caution regarding the use of convenience outlets. At time of completion, replace those items which have been damaged, including those burned and scored by faulty plugs.

TESTING

Test wiring devices to ensure electrical continuity of grounding connections, and after energizing circuitry, to demonstrate compliance with requirements.

655.07 Grounding

SUMMARY

Furnish labor and material to provide grounding facilities for the entire electrical installation as required by all inspecting and jurisdictional authorities as herein specified. The following are included, but not limited to, as items requiring grounding:

- Electrical service neutral conductor.
- Neutral conductor of all transformer secondaries.
- Conduits, boxes and other conductor enclosures. Neutral or identified conductor of interior wiring system.
- Distribution panels, power and lighting panel boards.
- Non-current - carrying parts of fixed equipment, such as transformers, motors, starters, control cabinets, disconnects, lighting fixtures, stand-by generator, etc.
- Metallic cabinets and auxiliary systems cabinets.

EQUIPMENT

Furnish and install all boxes and/or access plates required for installation and inspection of grounding connections to cold water piping system or other made electrodes.

Provide brass identifying tags on all ground clamps.

INSTALLATION

Ground connections made to metallic cold water piping system at such locations as will be readily available for inspection. Provide jumper connections around all meters and shut off devices.

Where cold water piping is not available for ground connections, use other available or made electrodes as described in NEC Sections 250-81 or 250-83.

Conduit Grounding: All grounding bushings within all enclosures, including equipment enclosures, shall be wired together and connected internally to the enclosure grounding lug or grounding bus with bare copper conductor. Grounding conductors sized in accordance with NEC shall be used with all grounding bushings.

Equipment Grounding: All electrical equipment shall be grounded. Most other equipment will be furnished with grounding pads or grounding lugs. All ground connections shall be cleaned immediately prior to connection. The Contractor shall provide all grounding material required but not furnished with the equipment.

No grounding conductor shall be smaller than 12 AWG wire unless it is a part of an acceptable cable assembly.

SPECIAL PROVISIONSECTION 655ELECTRICAL

(Installation of ORT Control Cabinet)

RELATED DOCUMENTS

Examine Drawings, Contract Conditions and all other Sections of the Specifications for requirements which affect work of this Section whether or not such work is specifically mentioned in this Section.

Coordinate work with that of all other trades affecting, or affected by work of this Section. Cooperate with such trades to assure the steady progress of all Project work.

Description

The purpose of this section is to provide information related to the work required to prepare the location of the lane controller cabinets as well as mount and install the ORT control cabinets. A concrete pad shall be installed as designed in the Plan drawings.

Mounting cleats which are supplied by the SI shall be attached to the tunnel wall, stainless steel Hilti bolts may be substituted for cleats with Resident approval. Conduit, wires and cables shall be pulled to the ORT Control and looped. Once the ORT Control is placed and connections to the cabinet have been made the SI will terminate all wiring. The Contractor may be required to be present when the SI terminates to perform any additional work necessary. All work shall be coordinated with the Resident and SI.

Installation

The Contractor shall install and connect all conduit, wireway, power and data wires associated with the proposed ORT Control Cabinets. The SI shall terminate all toll equipment wiring in the ORT Control Cabinets. The Contractor shall install a concrete pad as detailed in the Plan drawings for each of the ORT Control cabinets to be mounted on.

The Contractor will be required to:

- a. Install concrete pads as detailed in the Plan drawings, including reinforcement.
- b. Install SI provided mounting cleats to tunnel wall and cabinets in accordance with manufacturer and SI standards.
- c. Terminate clean power into three quadplex receptacles or provide alternate termination as shown on the Plans or directed by the Resident and SI. Power termination requirements to be confirmed in the field. The quadplex receptacles shall be white with stainless steel cover.
- d. Pull data/power from lane equipment into the ORT Control Cabinets with a 36-inch service loop for all data lines (including 120 volt data);

- e. Label each wire coming into the ORT Control Cabinets with numbered tags per wiring schedules and subject to approval as directed by the Resident and SI at the start of the project. Tags shall be neat, legible, waterproof, and approved by the SI/ the Resident.
- f. Cap or otherwise prep the ends of all conduit and wiring associated with the proposed lane controller such that these components will be sealed from any environmental impacts prior to installation of the ORT Control Cabinet.

Basis of Payment

Measurement and payment for mounting and installation work associated with the ORT Control cabinets as shown on the Plan drawings and described herein will be per each item. Installation of receptacles and completion of all conduits and wiring associated with the cabinet shall be incidental.

Pulling power wires and data cables as required for the new ORT Control Cabinet and associated equipment as shown on the Plan drawings will be incidental. All new conduit, wireway, wires and data cables installed will be paid under its appropriate pay item.

Payment will be made under:

<u>Pay Item</u>	<u>Pay Unit</u>
655.01 Installation of ORT Lane Controller Cabinet	Each

SPECIAL PROVISIONSECTION 655ELECTRICAL

(Installation of Cash Lane Controller Cabinet)

RELATED DOCUMENTS

- A. Examine Drawings, Contract Conditions all other Sections of the Specifications for requirements which affect work of this Section whether or not such work is specifically mentioned in this Section.
- B. Coordinate work with that of all other trades affecting, or affected by work of this Section. Cooperate with such trades to assure the steady progress of all Project work.

Description

The purpose of this section is to provide information related to the work required to prepare the location for the proposed lane controller (LC) cabinet to be installed by the Contractor. This section provides information on how the work by the Contractor will take the LC into consideration.

Submittals

A minimum of five days prior to the installation of the LC cabinet, the Contractor will be required to submit three copies of a neat line sketch of the proposed lane controller cabinet location detailing proposed conduit/wireway runs (calling out conduit/wireway sizes and the specific cables/wires in each conduit/wireway) to the LC, AVI, Sensor loops, TCP, DVAS, MLT, RP, Proximity Reader, COS and OPUS (As shown in the Plans). Included with this sketch will be the Plaza Work checklist from Appendix D that the Contractor must complete, indicating what cables will be routed into the new LC, how much slack is required in each of these cables, and any extra work that is required. The Resident/SI will have three working days to review the submittal. Work done for this submittal will be incidental to mobilization. After this submittal the exact location of the LC installation will be confirmed by the Resident and the SI. Also to be confirmed by the Resident and the SI will be the number, size and location of the conduits entering the LC cabinet, conduit/wireway layouts in pit/tunnel and entering the pit/tunnel, canopy and booth, islands, under slabs, etc.

Installation

The Contractor shall install all conduit/wireway and power, and data wires, associated with the proposed LC within the LC cabinet so as to be able to connect proposed peripherals to the new LC at the time of installation by the SI.

The Contractor will be required to:

- a. Terminate clean power into the LC cabinet via a single duplex receptacle or provide alternate termination as directed by the Resident and the SI. Power termination requirements to be confirmed in the field;
- b. Pull data/power from lane equipment into the LC cabinet with a 36-inch service loop for all data lines (including 120 volt data);
- c. Label each wire coming into the LC cabinet with numbered tags as directed by the Resident and the SI at the start of the project. Tags shall be neat, legible, waterproof, and approved by the SI/ Resident.

Basis of Payment

Measurement and payment for preparation work associated with the LC cabinet as shown on the Plan drawings and described herein will be per each item. Installation of the LC cabinet, installation of receptacles, completion of all conduits and wiring associated with the cabinet shall be incidental.

All new conduit/wireway installed will be paid under its appropriate pay item.

Payment will be made under:

<u>Pay Item</u>	<u>Pay Unit</u>
655.012 Installation of Cash Lane Controller Cabinet	Each

SPECIAL PROVISION

SECTION 655

ELECTRICAL

(DVAS Mount Installation)

Description

The Contractor shall mount a Pelco EM2200 hook to the underside of the space frame or canopy to accept a Costar CHG3000S enclosure for the DVAS camera. The Pelco hook shall be supplied by the SI. The Contractor will be responsible for mounting the hook. The mounting hardware shall be mounted directly to the space frame or canopy. Final location shall be approved by the Authority. Any additional hardware required will be incidental to the pay item.

Basis of Payment

Measurement and payment for work the DVAS mount installation as shown on the Plan drawings and described herein will be per each item.

Payment will be made under:

<u>Pay Item</u>	<u>Pay Unit</u>
655.02 DVAS Mount Installation	Each

SPECIAL PROVISION

SECTION 655

ELECTRICAL

(VCARS Mount Installation)

Description

The Contractor shall mount a 3-inch outside diameter round schedule 40 steel pipe using the long-tangent U-bolts supplied by the SI in the VCARS mounting kit. The Contractor must leave three feet of clearance between the bottom of the space frame and the top of the mounting pipe for the VCARS unit.

Basis of Payment

Measurement and payment for work the VCARS mount installation as shown on the Plan drawings and described herein will be per each item. All materials not provided in the mounting kit, labor and hardware are incidental to the pay item.

Payment will be made under:

<u>Pay Item</u>	<u>Pay Unit</u>
655.03 VCARS Mount Installation	Each

SPECIAL PROVISION

SECTION 655

ELECTRICAL

(Installation of Sensor Loops)

Description

The Contractor shall sawcut concrete pavement slab as directed by the Resident and according to Plans and detailed manufacturer’s instructions provided prior to installation. Given the proprietary nature of the loop installation requirements, the manufacturer’s instructions will only be provided to the awarded Contractor. Loop installation will involve multiple sawcuts within the limits indicated on the Plans and per manufacturer provided templates. Templates for loop cutting outlines shall be provided by the SI. No loop installation activities shall be done without the SI representative on-site. The SI will also provide the required materials for sealing the loops including but not limited to the required epoxy, pump and related injection equipment prior to the SI placing sensor loops. The Contractor shall be responsible for obtaining and operation of required sawcutting equipment. Loop cuts shall not be run out of the scabbled area for the epoxy overlay.

NOTE: All dust must be contained so that no silica reaches Authority employees or patrons. This may be accomplished by using wet saws, advanced air filter systems or by building an enclosure around the work area. The Contractor shall provide the Resident a 5-day notice prior to any sawcutting activities.

Basis of Payment

Payment to be made as lump sum for all associated Sensor loops shown on Plan drawings. Sawcutting of pavement, installation of epoxy and loops will be incidental to item.

Payment will be made under:

<u>Pay Item</u>	<u>Pay Unit</u>
655.04 Installation of Sensor Loops	Lump Sum

SPECIAL PROVISION

SECTION 655

ELECTRICAL

(Installation of AVI Antennas)

Description

The Contractor shall pick up AVI antennas and mounting equipment at the SI warehouse or a nearby maintenance yard as coordinated by the Resident. The Contractor shall install antennas and mounts in accordance with the manufacturer’s instructions. Antenna wires shall be installed and looped, the SI will terminate equipment wiring while the Contractor is onsite. If the SI requires additional work during termination and testing the Contractor must be present to assist.

Basis of Payment

Measurement and payment for work associated with the installation of AVI antennas as shown on the Plan drawings and described herein will be per each item. The Contractor will not pay for the purchase of antennas or the AVI equipment vendor’s presence to terminate and tune equipment.

Payment will be made under:

<u>Pay Item</u>	<u>Pay Unit</u>
655.05 Installation of AVI Antennas	Each

SPECIAL PROVISION

SECTION 655

ELECTRICAL

(Installation of AVI Readers)

Description

The Contractor shall pick up AVI readers at the SI warehouse or a nearby maintenance facility or delivered by the SI as coordinated by the Resident. The Contractor shall install readers in NEMA 4X cabinets mounted on space frame pedestals or in the tunnel as shown on the Plans. AVI readers shall be installed in accordance with the manufacturer’s instructions with oversight by the SI onsite as needed (to be determined by Resident). Reader wires shall be installed and looped. The vendor will arrive to terminate wiring while the Contractor is onsite. If the AVI equipment vendor requires additional civil or electrical work during termination and testing the Contractor must be present to assist.

Basis of Payment

Measurement and payment for work associated with the installation of AVI readers as shown on the Plan drawings and described herein will be per each item. The Contractor will not pay for the purchase of readers or the AVI equipment vendor’s presence to terminate wiring and tune equipment.

Payment will be made under:

<u>Pay Item</u>	<u>Pay Unit</u>
655.06 Installation of AVI Readers	Each

SPECIAL PROVISIONSECTION 655ELECTRICAL

(Traffic Control Pedestal Preparation Work)

Basis of Payment

Measurement and payment for preparation work for the Traffic Control Pedestals (TCP) as shown on the Plan drawings and described herein will be per each item. Note the procurement and installation of the TCP will be by the SI. Preparation work shall include drilling and installing threaded rods with adhesive and protection of associated wiring for the TCP in advance of installation of the TCP by the SI. The Contractor shall provide the following items or approved equals for the TCP anchorage system:

- 4 each – 5/8” x 9” Hilti HAS 304SS threaded rods, nuts (double nut), flat and lock washers.
- 4 each - Hilti HVU adhesive capsules, or approved equal epoxy
- 4 each – 5/8” SS nuts and fender washers for shimming and leveling the pedestal base.

Steps involved for installation of threaded rods are as follows:

1. Using the Pedestal Base detail in Appendix E as a template, layout and drill four 3/4” holes for the 5/8” threaded rods 10 inches deep.
2. Using a compressor and wire brush blow gun, clean out the anchor holes.
3. Use the shop vacuum to clean up all of the concrete dust and metal shavings.
4. For all concrete island installations, install the four 5/8-inch Hilti HAS 304SS threaded rods (using HVU adhesive capsules according to the manufacturer’s instructions, or approved equal epoxy).

Final location of TCP and alignment of threaded rod pattern layout shall be confirmed by the Resident, the MTA and the SI prior to threaded rod installation.

Payment will be made under:

<u>Pay Item</u>	<u>Pay Unit</u>
655.07 Traffic Control Pedestal Preparation Work	Each

SPECIAL PROVISION

SECTION 655

ELECTRICAL

(OPUS Mount Installation)

Description

The Contractor shall mount a 2.5-inch nominal diameter round schedule 40 steel pipe using U-bolts supplied by the SI, with the lowest point of its hood flange 17'-6" above the roadway surface. The Contractor must leave three feet of clearance between the bottom of the space frame and the top of the mounting pipe for the OPUS unit.

Basis of Payment

Measurement and payment for work the OPUS mount installation as shown on the Plan drawings and described herein will be per each item.

Payment will be made under:

<u>Pay Item</u>	<u>Pay Unit</u>
655.08 OPUS Mount Installation	Each

SPECIAL PROVISION

SECTION 655

ELECTRICAL

(Armored Cable – 10/3)

Description

This task shall include the providing and installation of armored cable wire, as described herein for clean and dirty power wiring, and other locations called for in the Plans and Specifications.

Wire: as previously specified in the technical provisions of wires & conductors.

Basis of Payment

Measurement and payment for the installation of armored cable wire as described herein will be per foot, to the nearest 10-foot interval per run. It shall include the furnishing, installation, routing, termination, splices and connection of the wire per the wiring schedule.

Payment will be made under:

<u>Pay Item</u>		<u>Pay Unit</u>
655.09	Armor Cable – 10/3	Linear Foot

SPECIAL PROVISIONSECTION 655ELECTRICAL

(AWG Wire)

Description

This task shall include the providing and installation of the AWG wire, as described herein for clean and dirty power wiring, for grounding wires (where applicable) and other locations called for in the Plans and Specifications. All wire installed in conduit must be burial grade, suitable for wet locations.

Basis of Payment

Measurement and payment for the installation of the AWG wire as described herein will be per foot, to the nearest 10-foot interval per run. It shall include the furnishing, installation, routing, termination, splices, marking and labelling and connection of the wire per the wiring schedule.

Payment will be made under:

<u>Pay Item</u>		<u>Pay Unit</u>
655.100	#2/0 AWG Wire	Linear Foot
655.1001	#1/0 AWG Wire	Linear Foot
655.1003	#3/0 AWG Wire	Linear Foot
655.101	#1 AWG Wire	Linear Foot
655.102	#2 AWG Wire	Linear Foot
655.104	#4 AWG Wire	Linear Foot
655.106	#6 AWG Wire	Linear Foot
655.11	#10 AWG Wire	Linear Foot
655.12	#12 AWG Wire	Linear Foot
655.13	#14 AWG Wire	Linear Foot

SPECIAL PROVISION

SECTION 655

ELECTRICAL

(4pr/24 (Category 5e) Cable)

Description

This task shall include the providing and installation of the Category 5e cable shown on the Plan drawings and described herein.

Cable: 4 pair, 24 AWG, Category 5e, twisted pair cable. Conductor material shall be bare copper, inner jacket material shall be PVC, cable shall be insulated and unshielded. Must be direct burial type suited for harsh conditions 4pr/24 category 5e cable, as approved.

Basis of Payment

Measurement and payment for the installation of the 4pr/24 category 5e cable will be by linear foot to the nearest 10-foot interval. It shall include the furnishing, installation and routing of the cable per the wiring schedule.

Payment will be made under:

<u>Pay Item</u>		<u>Pay Unit</u>
655.14	4pr/24 (Category 5e) Cable	Linear Foot

SPECIAL PROVISION

SECTION 655

ELECTRICAL

(LMR 400 Cable)

Description

This task shall include the providing and installation of the LMR 400 cable shown on the Plan drawings and described herein. The Contractor will terminate the LMR 400 Cable with the RF Male-RFN-100631 and RF Female-RFN-1028-SI. The male terminal end is at the antenna and the female terminal end is at the AVI Reader. The Contractor shall solder the end of the terminal end pins instead of crimping.

Cable: LMR 400 cable, as approved.

Basis of Payment

Measurement and payment for the installation of the LMR 400 cable will be by linear foot to the nearest 10-foot interval. It shall include the furnishing, installation, routing of the cable per the wiring schedule and terminating.

Payment will be made under:

<u>Pay Item</u>	<u>Pay Unit</u>
655.15 LMR 400 Cable	Linear Foot

SPECIAL PROVISIONSECTION 655ELECTRICAL

(Fiber Optic Cable – 6 Fiber)

Description

This task shall include the providing and installation of 62.5/125-micron multimode fiber optic cable as shown on the Plan drawings and described herein for all toll equipment application. The following Specifications for the selection and installation of fiber-optic cable and associated hardware are intended to ensure a reliable and consistent fiber optic media infrastructure for the MTA. All fiber optic cable termination and the fiber optic patch panels will be provided by the Contractor. Fiber optic patch panels shall be a Panduit FCE2U or approved equal. All fiber terminations and testing will be completed by a technician certified to perform this work.

Cable: 6-Fiber multi-mode Fiber, 100 mbs, 62.5/125 Microns, Indoor/Outdoor Riser Rater, ST (Male) Connection, as approved

Specifications: Fiber installed must meet or exceed the following Specifications:

- Multimode fiber installed cable shall be 62.5/125micron core/cladding, enhanced grade, multimode, and graded index glass fiber. All materials in the cable shall be dielectric.
- Installed fiber must meet or exceed the following performance Specifications:

Wavelength (nm)	Max. Attn.(dB/Km)	Min. (Mhz*Km)	Bandwidth
850	3.0	200	
1,300	0.9	500	

- Plenum rated cable shall be used for all interior installations. Plenum rated cable shall be:
 - Tight buffered 900 um
 - Mechanical strippable Teflon (for plenum applications)
 - EIA/TIA -598 color coding for fiber optic cable
 - Aramid yarn strength member
 - Capable of supporting a short-term tensile load of 400 lb. without stretching.
 - Capable of bend radii as small as 20 x outside cable diameter (under installation load) and 10 x outside cable diameter (long term load)
 - Capable of a minimum crush resistance of 850 lb./in.

- Corning fiber shall be the only fiber optic cable used for installation. Cable from other manufacturers will NOT be considered. All cable installed must be accepted by MTA prior to installation.

All cable is to be fully supported throughout its entire run.

At no time shall more than 400 pounds of tension be placed on any fiber cable while it is being pulled through tray or conduit. It is preferred that all fiber cable be pulled with hand power only. If power winches or mechanical advantage devices are used to pull cable, a tension meter must be used to ensure that maximum tension is not exceeded. Alternatively, a "mechanical fuse" rated at 350 pounds may be included in the linkage. Torsion shall be avoided by the use of a swivel at the cable end. While under tension, a minimum bend radius of 20 times the outside cable diameter will be maintained through the use of pulleys and sheaves where required. After pulling, no bend may have a radius, at rest, of less than 10 times the outside cable diameter.

Each cable is to be permanently labeled at each end with a unique cable number. In addition, labels shall be affixed to the cable at every transition of a vault, hand hole, riser closet, or major pull box.

Each fiber optic strand shall be labeled with a unique identifier at the ST coupler.

Fiber ends are to be terminated in ST-type connectors. No splices will be permitted. The cable shall be continuous run from LC to server room fiber switch location.

At each end of the cable, sufficient slack (25') shall be left to facilitate reasonable future relocation of the fiber switch or LC. Slack shall be mounted on walls or upper ladder racks.

Testing: Contractor shall test all long reels with an OTDR for length and transmission anomalies while on the reel prior to installation. It is suggested that each individual fiber in a cable regardless of length be tested with an OTDR for length and transmission anomalies while on the reel before installation.

All multimode fiber strands shall be tested end-to-end for bi-directional attenuation, 850 nm/1300 nm for multimode. Tests should be conducted in compliance with EIA/TIA-526-14 or OFSTP 14, Method B, according to the manufacturer's instructions for the test set being utilized.

Tests must ensure that the measured link loss for each strand does not exceed the "worst case" allowable loss defined as the sum of the connector loss (based on the number of mated connector pairs at the EIA/TIA-568 B maximum allowable loss of 0.75 dB per mated pair) and the optical loss (based on the performance standard above, 2.1.1 and 2.2.1).

After termination, each fiber shall be tested with an ODTR for length, transmission anomalies, and end-to-end attenuation. Results are to be recorded and supplied to MTA in the form of hard-copy printouts or photographs of screen traces.

After termination, each terminated fiber is to be tested for end-to-end loss with a power meter/light source. As above, results are to be recorded and supplied to MTA.

The Contractor shall review all end faces of field terminated connectors with a fiber inspection scope following the final polish. Connector end faces with hackles, scratches, cracks, chips and or surface pitting shall be rejected and repolished or replaced if repolishing will not remove the end face surface defects. The recommended minimum viewing magnifications for connector ends are 100X for multimode fiber and 200X for single mode fiber.

Basis of Payment

Measurement and payment for the installation of the Fiber Optic cable will be by linear foot to the nearest 10-foot interval. It shall include the furnishing, installation, termination and routing of the cable per the wiring schedule.

Payment will be made under:

<u>Pay Item</u>	<u>Pay Unit</u>
655.16 Fiber Optic Cable – 6 Fiber	Linear Foot

SPECIAL PROVISION

SECTION 655

ELECTRICAL

(IVIS Homerun Loop Cable (IMSA 50-2 #14))

Description

This task shall include the providing and installation of the IVIS homerun loop cable (IMSA 50-2 #14 AWG) shown on the Plan drawings and described herein.

Cable: IMSA 50-2 #14 AWG cable loop detector wire shall be as follows:

- Conductors: Solid or stranded tin copper
- Insulation: Polyethylene
- Conductor Configuration: Twisted pair
- Shield: Aluminum/Mylar tape
- Outer Jacket: Low-density polyethylene

Cable shall have two conductors, #14 AWG, 19 strand. Cable must be direct burial grade suitable for installation in the tunnel, beneath the roadway, within the barrier and any other locations shown on the Plan or described within the design documents. All loop sensor homerun cables shall have tape with length markings.

Basis of Payment

Measurement and payment for the installation of the IMSA 50-2 #14 AWG cable will be by linear foot to the nearest 10-foot interval. It shall include the furnishing, installation and routing of the cable per the wiring schedule. Use of "Klik-Its" is incidental.

Payment will be made under:

<u>Pay Item</u>	<u>Pay Unit</u>
655.17 IVIS Homerun Loop Cable (IMSA 50-2 #14)	Linear Foot

SPECIAL PROVISIONSECTION 655ELECTRICAL

(PVC Conduit)

Description

This task shall include providing and the installation of PVC Conduit as shown on the Plan drawings and described herein. All conduit shall be installed per NEC specification. Connections to specialized fittings are to be compatible with adjoining conduit.

Joints shall be made in accordance with ASTM D 2855. Solvent cement shall meet the requirements of ASTM D 2564 with particular attention to matching the viscosity to the conduit size.

Joint adhesives shall be in accordance with ASTM D2517.

All conduit runs shall be watertight. Slope conduit to drain into junction boxes.

All empty conduits shall have a labeled pull string. Pull strings shall have length markings and should be used for long conduits over 50 feet or for all underground installations. Clean, plug and seal conduit ends after installation.

Basis of Payment

Measurement and payment for installing PVC Conduit as shown on the Plan drawings and described herein will be per linear foot of each type of underground or exposed conduit actually furnished, installed, and accepted at the Contract price per linear foot. It shall include the furnishing, installing, supporting and connection of the conduit and all various hardware necessary for the installation. This price shall include the cost of hand digging, trenching, or plowing; furnishing and installing the conduit; furnishing special backfilling materials, pull string, fittings, groundings and bonding; test cleaning interiors of conduits and all materials, labor, equipment and incidentals necessary to complete the work.

Payment will be made under:

<u>Pay Item</u>		<u>Pay Unit</u>
655.200	1½" Schedule 40 PVC Conduit	Linear Foot
655.2001	¾" Schedule 40 PVC Conduit	Linear Foot
655.2002	1" Schedule 40 PVC Conduit	Linear Foot
655.2003	2" Schedule 40 PVC Conduit	Linear Foot
655.201	3" Schedule 40 PVC Conduit	Linear Foot
655.202	4" Schedule 40 PVC Conduit	Linear Foot
655.2021	1" Schedule 80 PVC Conduit	Linear Foot
655.203	1½" Schedule 80 PVC Conduit	Linear Foot
655.2031	2" Schedule 80 PVC Conduit	Linear Foot
655.204	3" Schedule 80 PVC Conduit	Linear Foot
655.205	4" Schedule 80 PVC Conduit	Linear Foot
655.2051	6" Schedule 80 PVC Conduit	Linear Foot
655.2052	5" Schedule 80 PVC Conduit	Linear Foot

SPECIAL PROVISIONSECTION 655ELECTRICAL

(Galvanized Rigid Metal Conduit)

Description

This task shall include providing and the installation of Galvanized Rigid Metal Conduit (RMC) as shown on the Plan drawings and described herein. All fittings shall be threaded, or approved compression type (approved by the engineer and compatible with the conduit), so as to be waterproof. Conduit shall be installed and grounded per NEC regulations. All supports shall be hot dipped galvanized or stainless steel (approved by the engineer and compatible with the conduit).

Basis of Payment

Measurement and payment for furnishing and installing the Galvanized RMC as shown on the plan drawings, where necessary, and described herein will be per foot. It shall include the furnishing, installing, supporting and connection of the conduit and misc. hardware necessary for the installation.

Payment will be made under:

<u>Pay Item</u>		<u>Pay Unit</u>
655.2061	3/4" Galvanized Rigid Metal Conduit	Linear Foot
655.206	1" Galvanized Rigid Metal Conduit	Linear Foot
655.207	1½" Galvanized Rigid Metal Conduit	Linear Foot
655.2071	2" Galvanized Rigid Metal Conduit	Linear Foot
655.208	3" Galvanized Rigid Metal Conduit	Linear Foot

SPECIAL PROVISIONSECTION 655ELECTRICAL

(Liquid Tight Metallic Flexible Conduit)

Description

This task shall include providing and the installation of Liquid Tight Metallic Flexible Conduit as shown on the Plan drawings and described herein. All conduit shall be watertight with flexible PVC coating over galvanized steel flex tubing. Conduit shall be installed and grounded per NEC regulations. All supports for shall be hot dipped galvanized or stainless steel. Connections shall be specialized fittings to be compatible with adjoining conduit and watertight.

Basis of Payment

Measurement and payment for installing the Liquid Tight Metallic Flexible Conduit as shown on the Plan drawings and described herein will be per linear foot actually furnished, installed, and accepted at the Contract price per linear foot. This price shall include the cost of: furnishing and installing the conduit; pull string, fittings, groundings and bonding; test cleaning interiors of conduits and all materials, labor, equipment and incidentals necessary to complete the work.

Payment will be made under:

<u>Pay Item</u>		<u>Pay Unit</u>
655.209	1/2" Liquid Tight Metallic Flexible Conduit	Linear Foot
655.210	3/4" Liquid Tight Metallic Flexible Conduit	Linear Foot
655.2101	1 1/2" Liquid Tight Metallic Flexible Conduit	Linear Foot
655.2102	2" Liquid Tight Metallic Flexible Conduit	Linear Foot
655.2103	1" Liquid Tight Metallic Flexible Conduit	Linear Foot

SPECIAL PROVISIONSECTION 655ELECTRICAL

(Electrical Metallic Tubing Conduit)

Description

This task shall include the installation of the Electrical Metallic Tubing Conduit (EMT) as shown on the Plan drawings and described herein. All fittings shall be an approved compression type (approved by the engineer and compatible with the conduit). Conduit shall be installed and grounded per NEC regulations. All supports for conduit shall be galvanized steel (with similar or better galvanizing than the tubing). Fittings are to be joined using couplings as recommended by the manufacturer.

Basis of Payment

Measurement and payment for installing the EMT as shown on the Plan drawings and described herein will be per foot actually furnished, installed, and accepted at the Contract price per linear foot. This price shall include the cost of: furnishing and installing the conduit; pull string, fittings, groundings and bonding; test cleaning interiors of conduits and all materials, labor, equipment and incidentals necessary to complete the work.

Payment will be made under:

<u>Pay Item</u>		<u>Pay Unit</u>
655.2111	1" Electrical Metallic Tubing Conduit	Linear Foot
655.211	1 1/2" Electrical Metallic Tubing Conduit	Linear Foot
655.212	2" Electrical Metallic Tubing Conduit	Linear Foot
655.213	3" Electrical Metallic Tubing Conduit	Linear Foot
655.214	4" Electrical Metallic Tubing Conduit	Linear Foot
655.215	3/4" Electrical Metallic Tubing Conduit	Linear Foot

SPECIAL PROVISIONSECTION 655ELECTRICAL

(Installation of Pull Boxes)

Description

This task shall include providing and installing:

- The type A pull box for interior, dry locations as shown on the Plan drawings and detailed herein, or where used elsewhere.
 - Materials: 4" x 4" x 2" steel; equal to Appleton 4SD1 or better.
- The type C pull box as shown on the Plan drawings and detailed herein. The C pull box shall be installed in booth pits, or building utility pits, booth curtain walls or where PVC conduit is used.
 - Materials: 18" x 18" x 6", NEMA 3R; PVC.
- The type D pull box as shown on the Plan drawings and detailed herein, or where used elsewhere.
 - Materials: 6" x 6" x 4" NEMA 4X.
- The type E pull box as shown on the Plan drawings and detailed herein. The E pull box shall be installed in booths/buildings in dry locations to pull communications cables, or shown elsewhere on the Plans, or where needed to complete the work.
 - Materials: 6" x 6" x 6" steel, indoor rated; equal to Hoffman A-606CH or better.
- The type F pull box as shown on the Plan drawings and detailed herein. The F pull box shall be installed in booth pits, or building utility pits, or where this size is to be used in a wet location or exterior location.
 - Materials: 4" x 4" x 4" plastic, medium duty; equal to or better than Appleton JIC-2

If equipment is to be installed at a later date insure adequate slack in the junction box for termination and additional 4-inch for possible re-termination. For pass through junction boxes no slack is required. For specific equipment, the following guidelines apply:

- Sensor Loops: A single slack loop of 12" – 24" for convenience of splicing.
- DVAS: Slack loop to allow for distance to mounting location of camera plus an additional 3 feet.
- LC: 4 feet of slack at LC mounting location.

Basis of Payment

Measurement and payment for installing the pull boxes as shown on the Plan drawings and described herein will be per each item. It shall include the furnishing, installation, mounting of the box, and the drilling of holes into the box for conduits.

Payment will be made under:

<u>Pay Item</u>		<u>Pay Unit</u>
655.221	Type A Pull Box Inside	Each
655.222	Type C Pull Box in Tunnel/Booth Pit	Each
655.223	Type D Pull Box Outdoor Canopy	Each
655.224	Type E Pull Box Steel in Booth	Each
655.225	Type F Pull Box Outside	Each

SPECIAL PROVISION

SECTION 655

ELECTRICAL

(Galvanized Steel Junction Box)

Description

This task shall include providing and installing galvanized steel watertight junction boxes measuring 12" x 12" x 6" or 18" x 18" x 6" to provide an access point from rigid metal conduit to tolling equipment mounted to the space frame as shown in the Plan drawings. Junction boxes must be approved by Resident.

Basis of Payment

Measurement and payment for installing the junction boxes as shown on the Plan drawings and described herein will be per each item. It shall include the furnishing, installation, mounting of the box, and the drilling of holes into the box for conduits.

Payment will be made under:

<u>Pay Item</u>		<u>Pay Unit</u>
655.30	12" x 12" x 6" Galvanized Junction Box	Each
655.31	18" x 18" x 6" Galvanized Junction Box	Each

SPECIAL PROVISIONSECTION 655ELECTRICAL

(18" x 24" x 12" Junction Box)

Description

This task shall include providing and installing 18" x 24" x 12" watertight junction boxes to be cast-in-place into the barrier as shown in the Plan drawings. Junction box shall be nonmetallic (Quazite or equivalent) and able to be placed in concrete. Access must be provided through the top cover which shall be flush with the top of barrier after placement. Junction boxes must be approved by Resident.

Basis of Payment

Measurement and payment for installing the junction boxes as shown on the Plan drawings and described herein will be per each item. It shall include the furnishing, installation, mounting of the box, and the drilling of holes into the box for conduits.

Payment will be made under:

<u>Pay Item</u>		<u>Pay Unit</u>
655.40	18" x 24" x 12" Junction Box	Each

SPECIAL PROVISIONSECTION 655ELECTRICAL

(36" x 30" x 20" NEMA 4X Cabinet)

Description

Provide and install NEMA 4X stainless steel equipment cabinets as designated on the Plan drawings to house the AVI Readers. Cabinets shall provide a 19" EIA rack mounting rails as appropriate and shall provide sufficient space for the enclosed equipment. Doors for the equipment cabinets shall be secured with standard interchangeable cylinder locks that match the existing (BEST) system presently in use by MTA. A closed cell neoprene gasket shall be utilized to prevent water entry at the door. A handle controlled latching system shall be included to simplify access to the cabinets. The door shall be able to be opened and closed without need for separate latching hardware. Two 120-Volt single-phase three-wire circuit shall be furnished and installed for clean power and dirty power to a quadplex receptacle (Type 5-15R – half clean/half dirty power) that shall be provided within each cabinet as shown on the Plans. The quadplex receptacles shall be white/brown with stainless steel cover.

AVI Reader cabinets shall be NEMA-4X with minimum dimensions of:

- Height 36"
- Width 30"
- Depth 20"

AVI Reader cabinets shall be fabricated with internal pieces of aluminum angle that is positioned to support the reader and provide 19-inch wide rack mounting with minimum depth of 15 inches. The AVI Reader and associated contiguous RF rack height is 21.05 inches. Mounting shall be configured per RS-310 (EIA rack spacing).

Basis of Payment

Measurement and payment for installing the NEMA 4X Cabinets as shown on the Plan drawings and described herein will be per each item. It shall include the furnishing, installation, mounting of the box, and the drilling of holes into the box for conduits. Installation of receptacles and completion of all conduits and wiring associated with the cabinet shall be incidental.

Payment will be made under:

<u>Pay Item</u>	<u>Pay Unit</u>
655.42 36" x 30" x 20" NEMA 4X Cabinet	Each

SPECIAL PROVISIONSECTION 655ELECTRICAL

(60 AMP 3 Phase Panelboard Cabinet)

Description

Provide and install 60-amp 3 phase panelboard cabinet as designated on the Plan drawings and schedule. Panelboard cabinet shall be of the dead-front, safety type with space for 30 single pole breakers. Breakers shall be provided as per attached panel schedules. Cabinet shall be constructed of zinc coated sheet steel and shall conform to Underwriters Laboratories, Inc., Standard for Cabinet and Boxes.

Panelboard cabinet height shall not exceed 72-inch and shall be mounted so that the distance from the floor to center of the top circuit breaker will not exceed 6 feet. Cabinet shall be provided with trims having adjustable trim clamps. Trims, unless otherwise noted, shall be fitted with hinged doors. A panel schedule will be provided.

Basis of Payment

Measurement and payment for installing the panelboard cabinet as shown on the Plan drawings and described herein will be per each item. It shall include the furnishing, installation, mounting of the cabinet, and the drilling of holes into the box for conduits.

Payment will be made under:

<u>Pay Item</u>	<u>Pay Unit</u>
655.43 60 AMP 3 Phase Panelboard Cabinet	Each

York
400 Amp main disconnect in Toll Building

General Information

Panel ID Sub-panel Tunnel CP #4 Booth 6,7,8 and 9
 Panel Location Tunnel
 Fed From UPS / Bypass Switch

Breaker Details

Main Breaker 60 AMP

Phase Type

Three Phase

Voltage Type

120/208

Pole	Amps	Description - Booth - 6 and 7	Description - Booth - 8 and 9	Amps	Pole
1	15	Lane Controller - Lane 6	2 Lane Controller - Lane 8	15	1
1	15	CP Receptacles - Lane 6	4 CP Receptacles - Lane 8	15	1
1	15	DVAS - Lane 6	6 DVAS - Lane 8	15	1
1	15	Lane Controller - Lane 7	8 Lane Controller - Lane 9	15	1
1	15	CP Receptacles - Lane 7	10 CP Receptacles - Lane 9	15	1
1	15	DVAS - Lane 7	12 DVAS - Lane 9	15	1
		Spare	14 Clean Power AVI Reader	20	1
		Spare	16 Spare		
		Spare	18 Spare		
		Spare	20 Spare		
		Spare	22 Spare		
		Spare	24 Spare		
		Spare	26 Spare		
		Spare	28 Spare		
		Spare	30 Spare		

York
400 Amp main disconnect in Toll Building

General Information		Breaker Details		Phase Type	Voltage Type
Panel ID	Sub-panel Tunnel CP#3 ORT	Main Breaker 60 AMP		Three Phase	120/208
Panel Location	Tunnel				
Fed From	UPS / Bypass Switch				
Pole	Amps	Description - NB	Description	Amps	Pole
1	15	NB OPUS	2 SB OPUS	15	1
1	15	NB VCARS Lane - NB1	4 SB VCARS Lane - SB1	15	1
1	15	NB VCARS Lane - NB2	6 SB VCARS Lane - SB2	15	1
1	15	NB VCARS Lane - NB3	8 SB VCARS Lane - SB3	15	1
1	15	NB VCARS Lane - NB4	10 SB VCARS Lane - SB4	15	1
1	15	NB VCARS Lane - NB5	12 SB VCARS Lane - SB5	15	1
1	15	NB DVAS Lane - NB1	14 SB DVAS Lane - SB1	15	1
1	15	NB DVAS Lane - NB1	16 SB DVAS Lane - SB1	15	1
1	20	NB Clean Power AVI Reader #1	18 SB Clean Power AVI Reader #1	20	1
1	20	NB Clean Power AVI Reader #2	20 SB Clean Power AVI Reader #2	20	1
1	20	NB Clean Power Lane Controller	22 SB Clean Power Lane Controller	20	1
		Spare	24 Spare		
		Spare	26 Spare		
		Spare	28 Spare		
		Spare	30 Spare		

York
400 Amp main disconnect in Toll Building

General Information		Breaker Details		Phase Type		Voltage Type	
Panel ID	Sub-panel Tunnel DP-#4 ORT & Lane 5	Description	Amps	Description	Three Phase	Amps	120/208
Panel Location	Tunnel						
Fed From	Toll Building - Line power	Main Breaker 60 AMP					
Pole	Pole	Description	Amps	Description		Amps	Pole
1	1	NB ORT Space Frame Lights 1	15	NB ORT Space Frame Lights 1	1	15	1
1	1	NB ORT Space Frame Lights 2	15	NB ORT Space Frame Lights 2	3	15	1
1	1	NB ORT Variable SL Sign	15	NB ORT Variable SL Sign	5	15	1
1	1	NB ORT Reader #1 Dirty Power	20	NB ORT Reader #1 Dirty Power	7	20	1
1	1	NB ORT Reader #2 Dirty Power	20	NB ORT Reader #2 Dirty Power	9	20	1
2	2	Booth #5 Heat Pump	30	Booth #5 Heat Pump	11	15	1
2	2	Booth #5 Heat Pump	30	Booth #5 Heat Pump	13	15	1
1	1	Under Counter Heater Fan #5	20	Under Counter Heater Fan #5	15	15	1
1	1	DP receptacles #5 (Strip)	20	DP receptacles #5 (Strip)	17	20	1
1	1	Booth #5 lights	15	Booth #5 lights	19	15	1
		Spare		Spare	21		
		Spare		Spare	23		
		Spare		Spare	25		
		Spare		Spare	27		
		Spare		Spare	29		
		Spare		Spare	22		
		Spare		Spare	24		
		Spare		Spare	26		
		Spare		Spare	28		
		Spare		Spare	30		
		Spare		Spare	20 canopy lights #5		
		Spare		Spare	DP receptacles #5 (Quad)		
		Spare		Spare	Flashing Yellow Beacon #5		
		Spare		Spare	Lane use VMS		
		Spare		Spare	Lane use signal #5		
		Spare		Spare	SB ORT Reader #1 Dirty Power		
		Spare		Spare	SB ORT Reader #2 Dirty Power		
		Spare		Spare	SB ORT Variable SL Sign		
		Spare		Spare	SB ORT Space Frame Lights 2		
		Spare		Spare	SB ORT Space Frame Lights 1		

York
400 Amp main disconnect in Toll Building

General Information		Breaker Details		Phase Type	Voltage Type
Panel ID	Sub-panel Tunnel CP #2 Booth, 1,2,3, 4 and 5			Three Phase	120/208
Panel Location	Tunnel				
Fed From	UPS / Bypass Switch	Main Breaker 60 AMP			
	Pole	Amps	Description - Booth 1, 2 and 3		Amps
	1	15	Lane Controller - Lane 1	1	15
	1	15	CP Receptacles - Lane 1	3	15
	1	15	DVAS - Lane 1	5	15
	1	15	Lane Controller - Lane 2	7	15
	1	15	CP Receptacles - Lane 2	9	15
	1	15	DVAS - Lane 2	11	15
	1	15	Lane Controller - Lane 3	13	15
	1	15	CP Receptacles - Lane 3	15	20
	1	15	DVAS - Lane 3	17	
			Spare	19	
			Spare	21	
			Spare	23	
			Spare	25	
			Spare	27	
			Spare	29	
			Description - Booth 4 and 5		
			Lane Controller - Lane 4	2	
			CP Receptacles - Lane 4	4	
			DVAS - Lane 4	6	
			Lane Controller - Lane 5	8	
			CP Receptacles - Lane 5	10	
			DVAS - Lane 5	12	
			Clean Power AVI Reader	14	
			Spare	16	
			Spare	18	
			Spare	20	
			Spare	22	
			Spare	24	
			Spare	26	
			Spare	28	
			Spare	30	

SPECIAL PROVISION

SECTION 655

ELECTRICAL

(100 AMP 3 Phase Panelboard Cabinet)

Description

Provide and install 100-amp 3 phase panelboard cabinet as designated on the Plan drawings and schedule. Panelboard cabinet shall be of the dead-front, safety type with space for 40 single pole breakers. Breakers shall be provided as per the attached panel schedules. Cabinet shall be constructed of zinc coated sheet steel and shall conform to Underwriters Laboratories, Inc., Standard for Cabinet and Boxes.

Panelboard cabinet height shall not exceed 72-inch and shall be mounted so that the distance from the floor to center of the top circuit breaker will not exceed 6 feet. Cabinet shall be provided with trims having adjustable trim clamps. Trims, unless otherwise noted, shall be fitted with hinged doors. A panel schedule will be provided.

Basis of Payment

Measurement and payment for installing the panelboard cabinet as shown on the Plan drawings and described herein will be per each item. It shall include the furnishing, installation, mounting of the cabinet, and the drilling of holes into the box for conduits.

Payment will be made under:

<u>Pay Item</u>	<u>Pay Unit</u>
655.44 100 AMP 3 Phase Panelboard Cabinet	Each

York
400 Amp main disconnect in Toll Building

General Information		Breaker Details		Phase Type	Voltage Type
Panel ID	Sub-panel Tunnel DP #6 Booth 8 & 9			Three Phase	120/208
Panel Location	Tunnel				
Fed From	Toll Building - Line power	Main Breaker 100 AMP			
	Pole	Amps	Description - Booth #8		Amps
	2	30	Booth #8 Heat Pump	1	30
	2	30	Booth #8 Heat Pump	3	30
	1	20	Under Counter Heater Fan #8	5	20
	1	20	DP receptacles #8 (Strip)	7	20
	1	15	Booth #8 lights	9	15
	1	15	canopy lights #8	11	15
	1	15	Canopy Sign Lights #8	13	15
	1	15	Flashing Yellow Beacon #8	15	15
	1	20	Canopy Drain De-icing Tape	17	15
	1	20	DP receptacles #8 (Quad)	19	15
			Spare	21	20
			Spare	23	
			Spare	25	
			Spare	27	
			Spare	29	
			Description - Booth #9		
			2 Booth #9 Heat Pump	1	
			4 Booth #9 Heat Pump	3	
			6 Under Counter Heater Fan #9	5	
			8 DP receptacles #9 (Strip)	7	
			10 Booth #9 lights	9	
			12 canopy lights #9	11	
			14 Lane use signal #9	13	
			16 Lane Use Sign (VMS)	15	
			18 Flashing Yellow Beacon #9	17	
			20 DP receptacles #9 (Quad)	19	
			22 Spare	21	
			24 Spare	23	
			26 Spare	25	
			28 Spare	27	
			30 Spare	29	

York
400 Amp main disconnect in Toll Building

General Information		Breaker Details		Phase Type		Voltage Type	
Panel ID	Sub-panel Tunnel DP #5 Booth 6 & 7			Three Phase		120/208	
Panel Location	Tunnel						
Fed From	Toll Building - Line power	Main Breaker 100 AMP					
	Pole	Amps	Description - Booth #6		Description - Booth #7	Amps	Pole
	2	30	Booth #6 Heat Pump	1	2 Booth #7 Heat Pump	30	2
	2	30	Booth #6 Heat Pump	3	4 Booth #7 Heat Pump	30	2
	1	20	Under Counter Heater Fan #6	5	6 Under Counter Heater Fan #7	20	1
	1	20	DP receptacles #6 (Strip)	7	8 DP receptacles #7 (Strip)	20	1
	1	15	Booth #6 lights	9	10 Booth #7 lights	15	1
	1	15	canopy lights #6	11	12 canopy lights #7	15	1
	1	15	Lane use signal #6	13	14 Lane use signal #7	15	1
	1	15	Canopy Sign Lights #6	15	16 Lane Use Sign (VMS)	15	1
	1	15	Flashing Yellow Beacon #6	17	18 Flashing Yellow Beacon #7	15	1
	1	20	Canopy Drain De-icing Tape	19	20 DP receptacles #7 (Quad)	20	1
	1	20	DP receptacles #6 (Quad)	21	22 AVI Reader dirty power	20	1
			Spare	23	24 Spare		
			Spare	25	26 Spare		
			Spare	27	28 Spare		
			Spare	29	30 Spare		

York
400 Amp main disconnect in Toll Building

General Information		Breaker Details		Phase Type		Voltage Type	
Panel ID	Sub-panel Tunnel DP #3 Booth 3 & 4			Three Phase		120/208	
Panel Location	Tunnel						
Fed From	Toll Building - Line power	Main Breaker 100 AMP					
	Pole	Amps	Description - Booth #3		Description - Booth #4	Amps	Pole
	2	30	Booth #3 Heat Pump	1	2 Booth #4 Heat Pump	30	2
	2	30	Booth #3 Heat Pump	3	4 Booth #4 Heat Pump	30	2
	1	20	Under Counter Heater Fan #3	5	6 Under Counter Heater Fan #4	20	1
	1	20	DP receptacles #3 (Strip)	7	8 DP receptacles #4 (Strip)	20	1
	1	15	Booth #3 lights	9	10 Booth #4 lights	15	1
	1	15	canopy lights #3	11	12 canopy lights #4	15	1
	1	15	Lane use signal #3	13	14 Lane use signal #4	15	1
	1	15	Canopy Sign Lights #3	15	16 Canopy Sign Lights #4	15	1
	1	15	Flashing Yellow Beacon #3	17	18 Flashing Yellow Beacon #4	15	1
	1	20	Canopy Drain De-icing Tape	19	20 DP receptacles #4 (Quad)	20	1
		20	DP receptacles #3 (Quad)	21	22 AVI Reader dirty power	20	
			Spare	23	24 Spare		
			Spare	25	26 Spare		
			Spare	27	28 Spare		
			Spare	29	30 Spare		

York

400 Amp main disconnect in Toll Building

General Information		Breaker Details		Phase Type	Voltage Type
Panel ID	Sub-panel Tunnel DP #2 Booth 1 & 2	Description - Booth #1		Three Phase	120/208
Panel Location	Tunnel	Description - Booth #2			
Fed From	Toll Building - Line power	Main Breaker 100 AMP			
		Pole	Description		Amps
		2	Booth #1 Heat Pump	1	30
		2	Booth #1 Heat Pump	3	30
		1	Under Counter Heater Fan #1	5	20
		1	DP receptacles #1 (Strip)	7	20
		1	Booth #1 lights	9	15
		1	canopy lights #1	11	15
		1	Lane use signal #1	13	15
		1	Canopy Sign Lights #1	15	15
		1	Flashing Yellow Beacon #1	17	15
		1	Canopy Drain De-icing Tape	19	20
		1	DP receptacles #1 (Quad)	21	20
			Spare	23	
			Spare	25	
			Spare	27	
			Spare	29	
			24 Spare		
			26 Spare		
			28 Spare		
			30 Spare		
			2 DP receptacles #2 (Quad)	20	20
			22 AVI Reader dirty power		
			Under Counter Heater Fan #2	6	20
			DP receptacles #2 (Strip)	8	20
			Booth #2 lights	10	15
			canopy lights #2	12	15
			Lane use signal #2	14	15
			Canopy Sign Lights #2	16	15
			Flashing Yellow Beacon #2	18	15

SPECIAL PROVISION

SECTION 655

ELECTRICAL

(PVC Conduit Condulets)

Description

This task shall include the installation of PVC condulets where called for on the plans, or where called for on installation drawings. Fittings for PVC condulets are to be joined using couplings and approved solvent, as recommended by the manufacturer. Types of condulets include, but are not limited to “LB”, “T”, “LR”, “LL”. All openings shall have rubber gaskets.

Basis of Payment

Measurement and payment for installing the condulets as described herein will be per item. It shall include the furnishing, installation and mounting of the conduit, and all associated hardware.

Pay Items are as follows:

<u>Pay Item</u>	<u>Pay Unit</u>
655.50 2” PVC Conduit Condulets	Each
655.51 4” PVC Conduit Condulets	Each

SPECIAL PROVISION

SECTION 655

ELECTRICAL

(Rigid Metal Conduit Condulets)

Description

This task shall include the installation of Rigid Metal Conduit Condulets where called for on the plans, or where called for on installation drawings. The condulets shall be hot dipped galvanized and waterproof, with threaded couplings or approved compression type couplings (if recommended by the manufacturer and compatible with adjoining conduit). Types of condulets include, but are not limited to “LB”, “T”, “LR”, “LL”. All openings shall have rubber gaskets.

Basis of Payment

Measurement and payment for installing the condulets as described herein will be per item. It shall include the furnishing and installation and of the condulet, and all associated hardware.

Pay Items are as follows:

<u>Pay Item</u>		<u>Pay Unit</u>
655.511	3/4” Rigid Metal Conduit Condulets	Each
655.52	1” Rigid Metal Conduit Condulets	Each
655.53	1 1/2” Rigid Metal Conduit Condulets	Each
655.54	2” Rigid Metal Conduit Condulets	Each

SPECIAL PROVISIONSECTION 655ELECTRICAL

(Electrical Metal Tubing Condulets)

Description

This task shall include the installation of Electrical Metal Tubing (EMT) condulets where called for on the plans, or where called for on installation drawings. The condulets shall be hot galvanized steel and waterproof, with approved compression type couplings (if recommended by the manufacturer and compatible with adjoining conduit). Types of condulets include, but are not limited to “LB”, “T”, “LR”, “LL”. All openings shall have rubber gaskets.

Basis of Payment

Measurement and payment for installing the condulets as described herein will be per item. It shall include the furnishing, installation and mounting of the condulet, and all associated hardware.

Pay Items are as follows:

<u>Pay Item</u>		<u>Pay Unit</u>
655.55	3” Electrical Metal Tubing Condulets	Each
655.56	2” Electrical Metal Tubing Condulets	Each
655.57	1 1/2” Electrical Metal Tubing Condulets	Each
655.58	3/4” Electrical Metal Tubing Condulets	Each
655.59	1” Electrical Metal Tubing Condulets	Each

SPECIAL PROVISIONSECTION 655ELECTRICAL

(PVC Wireway)

Description

This task shall include providing and the installation of PVC wireway in the tunnel as shown on the Plan drawings and/or described herein. Wireways shall be PVC NEMA 3R, and shall be installed per NEC regulations. All supports for wireways shall be hot dipped galvanized or stainless steel.

Basis of Payment

Measurement and payment for installing the PVC wireways as shown on the Plan drawings and described herein will be per foot, to the nearest 2-foot increment above the final installed segment. It shall include the furnishing, installing, supporting and connection of the wireway and all misc. hardware necessary for the installation. It shall also include all end caps, covers, drilling of holes for conduits, fabrications for 90-degree bends, etc. All coupling, fitting, caps, covers and 90-degree bends shall be factory supplied and not fabricated on site.

Payment will be made under:

<u>Pay Item</u>		<u>Pay Unit</u>
655.63	4-inch x 4-inch PVC NEMA 3R Wireway	Linear Foot
655.64	6-inch x 6-inch PVC NEMA 3R Wireway	Linear Foot
655.65	8-inch x 8-inch PVC NEMA 3R Wireway	Linear Foot
655.66	12-inch x 12-inch PVC NEMA 3R Wireway	Linear Foot

SPECIAL PROVISIONSECTION 655ELECTRICAL

(Concrete Encased Conduit)

Description

This work shall consist of encasing all conduit within the limits of the proposed conduit raceway section between the penetration from the tunnel to the structural slab infill opening. This work shall be completed in accordance with the Specifications, in reasonably close conformity with the lines and grades shown on the Plans or as approved by the Resident.

Materials

Concrete shall conform to Section 502, Structural Concrete, using ¾-inch (19 mm) maximum size coarse aggregate (Class AAA).

PVC spacers shall be the interlocking type of strength and spacing to hold raceways straight and true with spacing between raceway outside diameter of no less than 3 inches, horizontal. Conduit must be laid out and spaced as depicted in the Plan drawings.

Duct-sealing compound shall be non-hardening, safe for contact with human skin, not deleterious to cable insulation, and workable at temperatures as low as 35°F. It shall be capable of withstanding temperature of 300°F without slump and of adhering to clean surfaces of plastic ducts, metallic conduits, conduit coatings, concrete, masonry, lead, cable sheaths, cable jackets, insulation materials, and common metals.

Waterproof membrane used for sealing duct bank penetration into tunnel shall be Tremco – Paraseal Membrane or an approved equal. A waterstop will be used in conjunction with the membrane and shall be Tremco Parastop or an approved equal. Both membrane and waterstop will be installed as per manufactures guidelines.

Execution

All raceways shall be securely fastened in place during construction and progress of the work. Concrete wall penetrations shall be plugged to prevent seepage of grout, water, or soil into the tunnel.

Trenches for conduit may be excavated manually or with mechanical trenching equipment where practical. Walls of trenches shall be essentially vertical so that a minimum of shoulder surface is disturbed. The Contractor shall ascertain the type of soil or rock to be excavated before bidding. All excavation shall be incidental to concrete encased conduit construction.

Saw cutting for the tunnel and slab penetrations shall be considered incidental. Excavation limits of the concrete encased conduit will in accordance with the details shown on the Plans, unless otherwise approved by the Resident to provide access to the outer tunnel wall.

Basis of Payment

Measurement and payment for work associated with the concrete encased conduit as shown on the Plan drawings and described herein will be per cubic yard of concrete, based on the concrete encased conduit section dimensions detailed with no deduction for the space occupied by the conduit.

All work and materials necessary to install the concrete encased conduit will be incidental to the item, including excavation and saw cutting of concrete tunnel wall penetrations and the structural slab infill locations. All new conduit, wireway, wires and data cables installed will be paid under its appropriate pay item.

Payment will be made under:

<u>Pay Item</u>	<u>Unit</u>
655.75 Concrete Encased Conduit	Cubic Yard

SPECIAL PROVISIONSECTION 655ELECTRICAL

(Lightning Suppression System)

Description

This task shall include furnishing and installing the lightning protection system for the ORT and the canopies. This work shall be completed in accordance with the Specifications, in reasonably close conformity with the lines and grades shown on the Plans or as approved by the Resident.

The task also includes obtaining a UL Master Label Certificate for the completed lightning protection as a UL Class I ordinary structure.

Submittals

1. Product Data: For air terminals and mounting accessories, grounding conductors, grounding electrodes, and ground connection equipment.
2. Shop Drawings: Detail lightning protection system, including air-terminal locations, conductor routing and connections, and bonding and grounding provisions. Include indications for use of raceway, data on how concealment requirements will be met, and calculations required by NFPA 780 for bonding of grounded and isolated metal bodies.
3. Qualifications: Qualification data for firms and persons specified in "Quality Assurance" Article to demonstrate their capabilities and experience. Include data on listing or certification by an NRTL or LPI.
4. Inspection: Field inspection reports indicating compliance with UL Master Label Certification.

Quality Assurance

1. Installer Qualifications: Engage an experienced installer who is an NRTL or who is certified by LPI as a Master Installer/Designer. Installer shall be UL listed as a lightning protection installer.
2. Listing and Labeling: All system components utilized in the installation shall comply with the Standard for Lightning Protection Components, UL 96A.

Coordination

Coordinate installation of lightning protection with installation of other tolling systems and components, including electrical wiring, supporting structures and materials, metal bodies requiring bonding to lightning protection components, and finishes.

Coordinate installation of air terminals attached to space frame with space frame manufacturer.

Products

Subject to compliance with requirements, provide products by one of the following manufacturers or approved equal:

1. Automatic Lightning Protection.
2. ERICO International Corporation.
3. Harger Lightning Protection, Inc.
4. Heary Bros. Lightning Protection Co. Inc.
5. Independent Protection Co.
6. Robbins Lightning Inc.
7. Thompson Lightning Protection, Inc.

Air Terminals shall be NFPA Class I, solid copper, 3/8" diameter, by 24" tall or 10" tall, as indicated on the Contract Drawings. Main roof conductors as down conductors shall be bare copper in sizes as indicated on the Contract Drawings. Grounding electrodes shall be copper-clad steel, 3/4" diameter by 10'-0" long.

Execution

All work shall conform to the requirements contained in the latest edition of UL 96A, Installation Requirements for Lightning Protection Systems, and in the latest edition of NFPA 780 Standard for the Installation of Lightning Protection Systems.

Install conductors with direct paths from air terminals to ground connections. Conductors shall be supported for their entire length without travel through free air. No bend of a conductor shall form an included angle of less than 90 degrees or have a radius of bend less than 8 inches.

Conductors shall not be directly attached to aluminum or galvanized steel. Do not combine materials that can form an electrolytic couple that will accelerate corrosion in the presence of moisture unless moisture is permanently excluded from junction of such materials.

Main conductors shall be fastened at intervals not exceeding 3 feet.

Down conductors shall be installed within Schedule 80 PVC conduit for physical protection.

Cable Connections: Use UL listed connectors or approved exothermic-welded connections for all conductor splices and grounding connections.

UL Inspection: Provide inspections as required to obtain a UL Master Label Certification for the system.

LPI Certification: Provide an inspection by an inspector certified by LPI to obtain an LPI certification.

Method of Measurement

Lightning Suppression Systems will be measured by lump sum for complete system installation as shown in the plans.

Basis of Payment

The accepted quantity of Lightning Suppression System will be paid for at the Contract unit price of lump sum which shall include excavation, air terminals, grounding rods, quazite grounding wells, heavy duty ground test wells with covers, copper wire, and all associated hardware, conduit and junction boxes for a complete operational system.

Payment will be made under:

<u>Pay Item</u>	<u>Unit</u>
655.80 Lightning Suppression System	Lump Sum

SPECIAL PROVISION

SECTION 655

ELECTRICAL

(Key Switch)

Description

A key switch similar to key switches in use within the toll system shall be installed in line between clean power panel and power lead for each pair of VES cameras and each DVAS camera.

Basis of Payment

Work shall include furnishing all materials and hardware, and labor and equipment to install. All conduit and wires will be paid under separate pay items.

Payment will be made under:

<u>Pay Item</u>		<u>Pay Unit</u>
655.81	Key Switch	Each

SPECIAL PROVISIONSECTION 655ELECTRICAL

(Receptacle Boxes)

Description

A convenience duplex outlet of NEMA type 5-15R may be required near new ORT lane controllers at a location to be determined by the Resident and the SI and in new toll booths. Covers shall be stainless steel.

NEMA type 5-15R receptacles are required for the Cash Lanes where shown on the Plan drawings and installation instructions. Additional receptacle locations maybe determined by the Resident and SI. Covers shall be stainless steel.

A Quadplex receptacle is two NEMA type 5-15R may be required near new ORT lane controllers and near Cash Lane controllers at a location to be determined by the Resident and the SI and in new toll booths. Covers shall be stainless steel.

Basis of Payment

Work shall include furnishing all materials and hardware, and labor and equipment to install. All conduit and wires will be paid under separate pay items.

Payment will be made under:

<u>Pay Item</u>		<u>Pay Unit</u>
655.82	Duplex Receptacle	Each
655.83	NEMA L5-30R Receptacle	Each
655.84	Quadplex Receptacle	Each

SPECIAL PROVISIONSECTION 655ELECTRICAL

(Space Frame Lighting)

Description

This task shall include furnishing, mounting and wiring the space frame lighting and FAA style photoeye sensors in accordance with these Specifications, and as shown on the Plans or as approved by the Resident.

Materials

Lighting fixtures shall be Cree Edge TSP or similar containing a minimum of 120 LEDs with a drive current of 525 mA. Driver housing and light fixture casing shall be watertight. Lighting fixtures shall be compatible with a universal voltage supply, 120-277 VAC, 50/60 Hz input. The lighting units shall come with a 10-year warranty and have an expected life minimum of 100,000 hours. Lighting fixtures shall be approved by the Resident. Each space frame lighting circuit shall be equipped with a photocell sensor.

Design of the mounting connections to attach the lighting fixtures to the space frame and of the photocell to the structure shall be provided by the Contractor once the details of the space frame are known and provided. The connections must be approved by a licensed engineer in the State of Maine prior to installation. Final locations and mountings to be approved by the Resident and the SI prior to installation of lighting and associated power conduits.

Execution

Lighting fixtures shall be installed as per; manufactures recommendations, NEC Standards, Plans, and Specifications.

The Contractor shall submit a proposed method of attaching all ancillary components to the space frame to the Resident for approval. The proposed attachment method shall not require drilling, welding or other attachment methods that will damage the space frame or its galvanized coating. Any areas of galvanized coating that are damaged by the Contractor during installation of ancillary components shall be repaired in accordance with ASTM A780.

Basis of Payment

The space frame lighting will be paid for at the Contract unit price of lump sum which shall include all associated hardware and mounting equipment required for a complete operational system. Conduit and wiring shall be paid for under the respective items.

Payment will be made under:

Pay Item

Pay Unit

655.90

Space Frame Lighting

Lump Sum

SPECIAL PROVISION

SECTION 655

ELECTRICAL WORK

(LED Canopy Light Fixture)

Description

This work shall consist of furnishing and installing two (2) new LED lights (surface mounted) per lane in the toll plaza canopy in accordance with these Specifications, and as shown on the Plans or as approved by the Resident.

General

The Contractor shall submit a shop drawing for installing new LED fixtures for approval.

Materials

Provide products produced by:

- CREE Inc. – 304 Series - PKG-304-40-DM-06-E-UL-BZ-350-J-40K

Method of Measurement

LED canopy light fixtures will be measured by each unit, installed, and accepted.

Basis of Payment

LED canopy light fixtures will be paid for at the Contract unit price each which payment shall be full compensation for furnishing and installation of the new light fixture, and all other materials, labor, tools, equipment and incidentals necessary to complete the work.

Payment will be made under:

<u>Pay Item</u>	<u>Unit</u>
655.92 LED Canopy Light Fixture	Each

SPECIAL PROVISIONSECTION 655ELECTRICAL WORK

(Toll Booth Electrical Installation)

Description

This work shall consist of furnishing and installing all non-toll electrical apparatus within the nine toll booths, as well as all associated lights, outlets, conduit, wiring, junction boxes and hardware within the limits shown on the Drawings. The work shall be phased as noted on the Plans and outlined in the Specification.

General

The Toll Booth Electrical Installation will include all non-toll electrical, to include the electrical portion of the HVAC systems as described in the Plans and within this Specification, and all labor, material and equipment needed to provide a fully functioning toll booth will be incidental to this item.

See Plan Sheet Electrical and Mechanical Booth Details.

This specification is intended to cover the materials, equipment, apparatus, and erection of a complete toll booth electrical system whether specifically mentioned or not.

Toll System electrical items will be paid separately under the individual items.

Method of Measurement

The Toll Booth Electrical Installation will be measured for payment by the lump sum, complete, in- place for the Toll Booth Electrical Installation.

Basis of Payment

Toll Booth Electrical Installation will be paid for at the lump sum price bid which shall be full compensation for the cost of furnishing all materials, equipment, supplies, tools, incidentals, and labor and supervision necessary to satisfactorily complete the work. Progress payment may be pro-rated for the completion of each booth.

Payment will be made under:

<u>Pay Item</u>	<u>Unit</u>
655.98 Toll Booth Electrical Installation	Lump Sum

SPECIAL PROVISIONSECTION 655ELECTRICAL WORK

(LED Bumper Beacon)

Description

This work shall consist of furnishing and installing one (1) new LED yellow flashing signal head on the center of the front cash lane bumper (surfaced mounted) per lane in the toll plaza cash lanes in accordance with these Specifications, and as shown on the Plans or as approved by the Resident.

General

The Contractor shall submit a shop drawing for installing new LED fixtures for approval.

Materials

Provide the following products per cash lane Bumper Beacon:

- Single section traffic signal 12” housing – Federal Yellow (Black Face), polycarbonate – McCain or equal
- Standard 12” signal tunnel visor – Federal Yellow, polycarbonate – McCain or equal
- Dual Circuit Mushroom Flasher unit (1 NB and 1 SB)- Federal Yellow – McCain or equal
- Single 12” LED yellow signal 120V – GE GTx LED Signal Module or equal

Method of Measurement

LED Bumper Beacon will be measured by each unit, installed, and accepted.

Basis of Payment

LED Bumper Beacon will be paid for at the Contract unit price each which payment shall be full compensation for furnishing and installation of the new Bumper Beacon, and all other materials, labor, tools, equipment and incidentals necessary to complete the work.

Payment will be made under:

<u>Pay Item</u>	<u>Unit</u>
655.99 LED Bumper Beacon	Each

SPECIAL PROVISIONSECTION 665ELECTRICAL WORK

(Communications)

Description

This work shall consist of furnishing and installing Intelligent Transportation Systems (ITS) communications equipment along the roadway within the limits of work and in the administration building in accordance with this Specification, the applicable 800 Division Specifications, and as shown on the Plans or as approved by the Resident.

General

The Contractor shall submit shop drawings for communications systems and all related hardware and electronics for approval.

Method of Measurement

The Communications item will be measured for payment by the lump sum, complete and accepted.

All work for Communication installation shall conform to the MaineDOT Specifications, MTA Supplemental Specifications, and the Special Provisions.

Basis of Payment

Communications item will be paid for at the lump sum price bid which shall be full compensation for the cost of furnishing all materials, equipment, supplies, tools, incidentals, labor and supervision necessary to satisfactorily complete the work in all respects, to the satisfaction of the Resident.

Payment will be made under:

Pay ItemPay Unit

665.002

Communications

Lump Sum

SPECIAL PROVISIONSECTION 712MISCELLANEOUS HIGHWAY MATERIALSection 712.061- Structural Precast Concrete Units

Under the heading, Quality Control and Quality Assurance, revise the fourth paragraph to read:

“Acceptance is the prerogative of the Department. The Department will conduct Quality Assurance (QA) in accordance with Standard Specification Subsection 106.5. Testing deemed necessary by the Department that is in addition to the minimum testing requirements will be scheduled to minimize interference with the production schedule. The QAI will perform acceptance sampling and testing and will witness or review documentation, workmanship and testing to assure the Work is being performed in accordance with the Contract Documents.”

Under the heading, Concrete Testing, revise the first paragraph to read as the following two paragraphs:

“Concrete Testing Acceptance of structural precast units, for each day’s production, will be determined by the Department, based on compliance with this specification and satisfactory concrete testing results. At least once per week, the QAI will make 2 concrete cylinders (6 cylinders when the Contract includes permeability requirements) for use by the Department; cylinders shall be standard cured in accordance with AASHTO T23 (ASTM C31). The QAI will perform entrained air content and slump flow testing, determine water-cement ratio and determine temperature of the sampled concrete at the time of cylinder casting. All testing equipment required by the QAI to perform this testing shall be in accordance with Standard Specification Section 502.041, Testing Equipment. In addition, the Contractor shall provide a slump cone meeting the requirements of AASHTO T 119. Providing and maintaining testing and curing equipment shall be considered incidental to the work and no additional payment will be made.

Quality Control test cylinders shall be made and tested in accordance with the following standards:

AASHTO T 22 (ASTM C39) Test Method for Compressive Strength of Cylindrical Concrete Specimens

AASHTO T23 (ASTM C31) Practice for Making and Curing Concrete Test Specimens in Field

AASHTO T141 (ASTM C172) Practice for Sampling Freshly Mixed Concrete

AASHTO T152 (ASTM C231) Test Method for Air Content of Freshly Mixed Concrete by the Pressure Method

AASHTO T196 (ASTM C173) Standard Test Method for Air Content of Freshly Mixed Concrete by the Volumetric Method

ASTM C1064 Test Method for Temperature of Freshly mixed Portland
Cement Concrete

ASTM C1611 Standard Test Method for Slump Flow of Self-
Consolidating Concrete”

Under the heading, Concrete Testing, delete the paragraph that begins: “At least once per week, the Contractor shall make 2 concrete cylinders.....for use by the Department.....”.

SPECIAL PROVISION

SECTION 719

SIGNING MATERIAL

Section 719.01 Reflective Sheeting

This Subsection is deleted in its entirety and replaced with the following:

Retroreflective sheeting for signs shall meet at a minimum the requirements for, ASTM 4956 – Type VII, Type VIII or Type IX (Prismatic), for all signs. All Type 1 Guide Signs shall meet at a minimum the requirements for ASTM 4956 –Type XI (Prismatic) sheeting.

Reflective sheeting, used in sign construction, shall have been manufactured within the six months immediately prior to the fabrication of each sign. Upon delivery at the job site of each shipment of signs, a letter of certification shall be provided that the reflective sheeting conforms to the requirements.

For Type 1 Guide Signs, all reflective sheeting shall be color matched on each sign unit.

All warning signs shall be fluorescent yellow except for Ramp Advisory Speed signs which shall be yellow.

All Construction Series signs that use orange backgrounds shall be fluorescent orange.

All Pedestrian Signs shall be fluorescent yellow-green.

EZ-PASS Purple shall conform to the FHWA Purple color block.

719.02 Demountable High Intensity Reflectorized Letters, Numerals, Symbols, and Borders

This Subsection, including the title, is deleted in its entirety and replaced with the following:

719.02 Direct Applied Reflectorized Letters, Numerals, Symbols, and Borders

Direct applied letters, numerals, symbols and borders shall consist of cut out sheeting shall meet at a minimum the requirements for ASTM 4956 – Type VII, Type VIII or Type IX (Prismatic) sheeting.

All Type 1 Guide Signs shall meet at a minimum the requirements for ASTM 4956 – Type IX (Prismatic) sheeting.

SPECIAL PROVISION

SECTION 800

MISCELLANEOUS INCIDENTALS

(HVAC Tunnel and Booths)

800.1 Description

This work shall consist of furnishing and installing materials and components for all mechanical, control, and HVAC systems as well as all other related mechanical equipment described in the Plans and Specifications.

The Contractor shall perform site visit(s) as needed prior to bid preparation to familiarize with and/or field verify the existing conditions to the extent that all incidental work required to complete the project scope is included in the base bid.

800.2 Work Included

The work in this item generally includes, but is not limited to installation of, or portions thereof, the following:

- a. Toll Booths: Associated HVAC system and components, including but not limited to heaters, vents, piping, valves, rollers, framing, bracing, actuators, thermostats, controllers, duct work, bi-lateral vents/dampers, and hangers.
- b. Tunnel: Mechanical and HVAC system components associated with toll booths, booth islands and canopy including but not limited to all mechanical supports, HVAC mechanical components, duct work, actuators, valves, dampers, heating coils, vents, control system components, and thermostats.

Mechanical, HVAC, and plumbing work is included in this item and is shown on the Plan drawings. Any subsidiary structural and/or architectural work required to complete the mechanical, HVAC, or plumbing work as shown or noted on the respective drawings shall be incidental to this pay item.

800.3 Method of Measurement

The HVAC Tunnel and Booths will be measured for payment by the lump sum, complete and accepted.

800.4 Basis of Payment

Payment to be made as lump sum for all HVAC for the Tunnel and Booths required as noted in the Plans. All labor and materials required will be incidental to this item.

Payment will be made under:

Pay Item

Pay Unit

800.22 HVAC Tunnel and Booths

Lump Sum

SPECIAL PROVISIONSECTION 800MISCELLANEOUS INCIDENTALS

(New Toll Booth Installation)

800.1 Description

Division 800 specifies materials, procedures, and requirements for the construction of the Toll Facilities, comprised of: installation of nine toll booths and all associated utilities and services within the limits shown on the Drawings. The work shall be phased as noted on the Plans and outlined in the Specification.

Toll Booth installation includes, but is not limited to the following:

1. Pick up, transport and installation of nine (9) toll booths complete with aluminum sub-frames, floors, doors, windows, counters, etc. Caulking and sealing of booths to concrete is part of the installation. Weather-stripping to be furnished by others.
2. Cutting, patching, and sealing as required to complete the work per Plans and Specifications.

All material associated with Toll Booths installation is included in this item and is shown on the Plan drawings and described in this Special Provision. Electrical and communication items associated with the toll system will be paid for under the specific item. Furnishing and installing plumbing, heating, and ventilating items in the toll booths will be paid for under Item 800.22 HVAC Tunnel and Booths.

The toll booth roofs are not capable of supporting construction loads (materials, equipment, construction workers, etc.). The Contractor is responsible for providing any necessary staging or temporary supports for accessing the toll booth roofs.

800.2 Method of Measurement

The Toll Booth installation will be measured for payment by the lump sum, complete, in-place for the Toll Booth installations.

The MTA will supply the toll booths for installation. The Contractor shall transport toll booths from Authority's Sign Shop Facility Mile 58.3 northbound. The installation will include all electrical, mechanical and toll systems required as described in the Plans and within this specification, and all labor, material and equipment needed to provide a fully functioning toll booth will be incidental to this item.

800.3 Basis of Payment

Toll Booths will be paid for at the lump sum price bid which shall be full compensation for the cost of furnishing all materials, equipment, supplies, tools, incidentals, and labor and supervision necessary to satisfactorily complete all work prescribed in Division 800 of these Special Provisions.

Payment will be made under:

Pay ItemPay Unit

800.51

New Toll Booth Installation

Lump Sum

SPECIAL PROVISIONSECTION 800BUILDING AND STRUCTURES

(Radon Mitigation System)

800.1 Description

Division 800 specifies materials, procedures and requirements for the construction of the Radon Mitigation System, complete with all appurtenances, including any and all associated utilities, equipment, and services within the limits shown on the Drawings and described herein.

The Contractor shall submit to the Resident for approval a cost breakdown of the major components of work for the Radon Mitigation System. This breakdown will be used as a basis for monthly pay estimates.

800.2 Work Included

All work for the Radon Mitigation System shall conform to the specifications provided in Part III, Division 800, except as noted herein. Radon Mitigation System construction includes, but is not necessarily limited to, the following:

1. Furnishing and installing perforated piping, crushed stone and vent pipes to the limits shown on the Plans.
2. Furnishing and installing junction boxes, wiring and fans.
3. All radon mitigation systems shall be designed and installed by a registered Radon Service Provider licensed in the State of Maine. The radon mitigation system shall be designed to avoid health, safety, and environmental hazards to building occupants related to back-drafting of natural draft combustion appliances. The radon mitigation system shall be designed to maximize radon reduction, minimize excess energy usage, minimize noise, and avoid compromising moisture and temperature controls and other comfort features. The radon mitigation system and its components shall be designed to comply with the laws, ordinances, codes, and regulations of relevant jurisdictional authorities including applicable mechanical, electrical, building, plumbing, energy and fire prevention codes.

800.4 Method of Measurement

The Radon Mitigation System will be measured for payment by the lump sum, complete and accepted.

All work for excavation, placement of crushed stone or compacted gravel, and backfill at foundation walls shall conform to Sections 203, 206 and 304 of the MaineDOT Specifications, MTA Supplemental Specifications, and the Special Provisions.

800.5 Basis of Payment

Utility building construction will be paid for at the lump sum price bid which shall be full compensation for the cost of furnishing all materials, equipment, supplies, tools, incidentals, labor and supervision necessary to satisfactorily complete the work in all respects, to the satisfaction of the Resident.

Payment will be made under:

<u>Pay Item</u>	<u>Pay Unit</u>
800.62 Radon Mitigation System	Lump Sum

SPECIAL PROVISIONSECTION 800MISCELLANEOUS INCIDENTALS

(Southbound and Northbound Plaza Canopies)

800.1 Description

Division 800 specifies materials, procedures and requirements for the construction of the Toll Facilities, comprised of: plaza canopies and all associated utilities and services within the limits shown on the Drawings. The work shall be phased as noted on the Plans and outlined in the Specification.

Southbound and Northbound Canopies:

The canopy construction includes, but is not limited to the following:

1. Steel fabrication and erection of plaza canopy steel structures complete, including decking, steel framing, canopy sign supports and anchorage assemblies as detailed on the Plans. For technical requirements, refer to the following sections provided in Part III Division 800:
 - **Section 05100 - Structural Steel Framing**
 - **Section 05310 – Steel Decking**
 - **Section 05500 – Metal Fabrications**
2. Installation of the new canopy roof will include EPDM roofing material, flashing, and all other architectural treatments as detailed on the Plans. For technical requirements, refer to the following sections provided in Part III Division 800:
 - **Section 07531 - EPDM Membrane Roofing**
 - **Section 07200 - Insulation**
3. Furnishing and installing the canopy roof drainage systems as detailed on the Plans. For technical requirements, refer to the following sections provided in Part III Division 800:
 - **Section 15400 - Plumbing**
 - **Section 16131 - Heat Tracing**
4. Furnishing and installing lighting, conduit and controls for overhead static canopy signs and all other electrical and communications items detailed on the Plans for the canopies. All conduit, wire to toll equipment shall be paid under the appropriate 655 item.

The Contractor shall submit a cost breakdown of the major components of work for the Canopies to be approved by the Engineer. This breakdown will be used as a basis for the monthly pay estimates.

800.2 Method of Measurement

The Canopy construction will be measured for payment by the lump sum, complete, in-place for the Canopies.

The Contractor shall install a new southbound canopy over Lanes 1 through 5; and install a new northbound canopy over Lanes 6 through 9 as shown on the Plans and described within these specifications. The canopy installations shall include complete roofing system, all electrical infrastructure, roof drainage systems, canopy sign supports and lighting for these signs and all material labor and equipment needed to provide the completed canopies.

The canopies shall be shop-painted as described in the Section 506. Shop painting of structural steel and hardware for canopies will be measured and paid for separately under Item 506.15 – Shop Coating of New Steel.

800.3 Basis of Payment

Southbound and Northbound Plaza Canopies will be paid for at the lump sum price bid which shall be full compensation for the cost of furnishing all materials, equipment, supplies, tools, incidentals, and labor and supervision necessary to satisfactorily complete all work prescribed in Division 800 of these Special Provisions and detailed on the Plans.

Payment will be made under:

<u>Pay Item</u>		<u>Pay Unit</u>
800.501	Southbound and Northbound Plaza Canopies	Lump Sum

SPECIAL PROVISIONSECTION 800BUILDING AND STRUCTURES

(Toll Administration Building)

800.1 Description

Division 800 specifies materials, procedures and requirements for the construction of the Toll Administration Building, complete with all appurtenances, including any and all associated utilities, equipment, and services within the limits shown on the Drawings and described herein.

The Contractor shall submit to the Resident for approval a cost breakdown of the major components of work for the Toll Administration Building. This breakdown will be used as a basis for monthly pay estimates.

800.2 Work Included

All work for the Toll Administration Building shall conform to the specifications provided in Part III, Division 800, except as noted herein. Toll Administration Building construction includes, but is not necessarily limited to, the following:

1. Construction of reinforced concrete first floor deck slab, footings, foundation walls and basement slab.
2. Furnishing and installing high performance waterproofing membrane system along the foundations to the limits shown on the Plans. All work for furnishing and installing the waterproofing system shall conform to Section 508, High Performance Waterproofing Membrane System (Tunnel and Tunnel Staircases) provided in Part II (Special Provisions) for this project.
3. Construction of masonry walls and brick façade.
4. Construction of structural steel framing and first floor deck forms.
5. Designing, furnishing, and installation of shop-fabricated wood roof trusses.
6. Construction of the Toll Administration Building proper, including all equipment and interior and exterior finishes.
7. Construction of steel railings at areaways and along building entries.
8. Construction of steel grating at areaways.
9. Furnishing and installing items required for building fire protection system.

10. Furnishing and installing plumbing, heating, ventilating, air conditioning, fire protection, and telephone, complete with all appurtenances and accessories.
11. Furnishing and installing electrical power, lighting, fire alarm, grounding, and lightning protection.
12. Coordinating with the utility to provide a transformer and connections.
13. Furnishing and installing secondary power conduit and wiring from the nearby utility transformer to the building including trenching and backfilling, conduit, wire, supports, brackets, junction boxes, etc. required to provide all work.
14. Furnishing and installing power wires and conduit from panels DP and CP in the new Toll Administration Building to clean and dirty power panels in the tunnel, complete with all appurtenances and accessories.
15. Furnishing and installing Telecommunications horizontal cabling and outlet/connectors, patch panels, equipment frames and racks, UPS, and video display systems, CCTV cameras.
16. Furnishing and installing Access Control security system hardware and devices, control system and security access cards. Contractor will be responsible for furnishing and installing all EACS supporting infrastructure (Pipe, wires, doors and door hardware). MTAs SI will furnish and install EACS edge equipment and core equipment, such as door controllers, door card readers, and acceptance testing.

800.3 Method of Measurement

The Toll Administration Building will be measured for payment by the lump sum, complete and accepted. The horizontal pay limits shall be the perimeter of the exterior masonry and concrete walls and include the entire Toll Administration Building, areaways, entry railings, all electrical components that service the pad-mounted exterior HVAC units, and all HVAC components that service the administration building including condensing units and associated piping. The vertical pay limit for this work shall be above the lower limit of the building foundations and sump pit. The exception to these pay limits shall be power cable and conduit from the Toll Administration Building to the panelboards located in the tunnel.

The following work will be measured and paid for separately:

1. Designing, furnishing, and installing the radon mitigation system.
2. Excavating rock and soil to install foundations and basement slab.
3. Filling and backfilling for building utilities, foundations and basement slab.
4. Fiber Optic Cable for toll cash ORT lanes.

All work for excavation, placement of crushed stone or compacted gravel, and backfill at foundation walls shall conform to Sections 203, 206 and 304 of the MaineDOT Specifications, MTA Supplemental Specifications, and the Special Provisions.

All work for construction of the toll administration building, with the exception of items listed above, will be included in Item 800.01 – Toll Administration Building. The work includes utility installations and all other work within the pay limits described herein and shown on the Plans for the building.

800.4 Basis of Payment

Toll Administration Building construction will be paid for at the lump sum price bid which shall be full compensation for the cost of furnishing all materials, equipment, supplies, tools, incidentals, labor and supervision necessary to satisfactorily complete the work in all respects, to the satisfaction of the Resident.

Payment will be made under:

<u>Pay Item</u>		<u>Pay Unit</u>
800.01	Toll Administration Building	Lump Sum

SPECIAL PROVISION

SECTION 800

MISCELLANEOUS INCIDENTALS

(Tunnel Access Hatch)

800.1 Description

The work shall consist of furnishing and installing materials and components as needed to provide the tunnel access hatch, complete in place.

800.2 Requirements

The tunnel access hatch shall be designed, constructed and installed as described in the sections found in Part III Division 800;

- **Section 07720 – Tunnel Access Hatch**

800.3 Method of Measurement

The tunnel access hatch will be measured for payment as one lump sum unit, complete in place, and accepted.

800.4 Basis of Payment

Payment will be made for work completed and accepted for tunnel access hatch at the Contract Lump Sum price. All labor and materials required will be incidental to this item.

Payment will be made under:

<u>Pay Item</u>	<u>Pay Unit</u>
800.41 Tunnel Access Hatch	Lump Sum

SPECIAL PROVISION

SECTION 800

MISCELLANEOUS INCIDENTALS

(Tunnel and Toll Stairway Lighting, Fire Alarm, and House Power)

800.1 Description

This work shall consist of furnishing and installing materials and components for all tunnel and toll stairway lighting, fire alarm, and house power as well as all other related electrical equipment described in the Plans and Specifications.

The Contractor shall perform site visit(s) as needed prior to bid preparation to familiarize with and/or field verify the existing conditions to the extent that all incidental work required to complete the project scope is included in the base bid.

800.2 Work Included

The work in this item generally includes, but is not limited to installation of, or portions thereof, the following:

- a. Tunnel and toll stairway: lighting, fire alarm, and house power components associated with the tunnel including but not limited to all light fixtures, exit signs, occupancy sensors, light switches, heat detectors, horn/strobes, pull stations, panelboards, receptacles, cable, and conduit mechanical system.
- b. Conduit and fittings for access control to tunnel doors (coordinate with MTA provider who will provide and install cable and control mechanisms).

Electrical work is included in this item and is shown on the Plan drawings. Any subsidiary structural and/or architectural work required to complete the electrical work as shown or noted on the respective drawings shall be incidental to this pay item.

800.3 Method of Measurement

The Tunnel and Toll Stairway Lighting, Fire Alarm, and House Power will be measured for payment by the lump sum, complete and accepted.

800.4 Basis of Payment

Payment to be made as lump sum for all Tunnel and Toll Stairway Lighting, Fire Alarm, and House Power required as noted in the Plans. All labor and materials required will be incidental to this item.

Payment will be made under:

Pay Item

Pay Unit

800.23

Tunnel and Toll Stairway Lighting, Fire Alarm, and
House Power

Lump Sum

SPECIAL PROVISIONSECTION 800MISCELLANEOUS INCIDENTALS

(Toll Administration Building Standby Generator)

800.1 Description

This work shall consist of furnishing and installing materials and components for the toll administration building standby generator as well as all other related electrical equipment described in the Plans and Specifications.

The Contractor shall perform site visit(s) as needed prior to bid preparation to familiarize with and/or field verify the existing conditions to the extent that all incidental work required to complete the project scope is included in the base bid.

800.2 Work Included

The work in this item generally includes, but is not limited to installation of, or portions thereof, the following:

- a. Toll Administration Building Standby Generator: standby diesel generator, weatherproof enclosure, sub-base fuel tank, work platforms, stairs, and concrete pad.
- b. Ductbank, conduit, electrical cables, and data cables, from the generator into the building.

Electrical work is included in this item and is shown on the Plan drawings. Any subsidiary structural and/or architectural work required to complete the electrical work as shown or noted on the respective drawings shall be incidental to this pay item. For technical requirements, refer to the following sections provided in Part III Division 800:

- **Section 03300 – Cast-in-place Concrete**
- **Section 16621 – Engine Generators**

800.3 Method of Measurement

The Toll Administration Building Standby Generator will be measured for payment by the lump sum, complete and accepted.

800.4 Basis of Payment

Payment to be made as a lump sum for the Toll Administration Building Standby Generator as noted in the Plans. All labor and materials required will be incidental to this item.

Payment will be made under:

Pay Item

Pay Unit

800.24

Toll Administration Building Standby Generator

Lump Sum

SPECIAL PROVISION

DIVISION 800

MISCELLANEOUS INCIDENTALS

(Tunnel Stair Enclosures)

800.1 Description

The work shall consist of furnishing and installing materials and components as needed to provide the completed tunnel stair enclosures at Lanes 2, 4, 7 and 9. The following work in this item generally includes, but is not limited to the following:

The stair enclosure construction includes, but is not limited to the following:

5. Steel fabrication and erection of stair enclosure framing, metal decking, steel framing, and anchorage assemblies as detailed on the Plans. For technical requirements, refer to the following sections provided in Part III Division 800:
 - **Section 05100 - Structural Steel Framing**
 - **Section 05310 – Steel Decking**
 - **Section 05500 – Metal Fabrications**

6. Installation of the enclosure roofs which includes EPDM roofing material, insulation and all other architectural treatments as detailed on the Plans. For technical requirements, refer to the following sections provided in Part III Division 800:
 - **Section 07531 - EPDM Membrane Roofing**
 - **Section 07500 - Insulation**

7. Installation of the aluminum doors, panels, fascia plates, and other architectural treatments as detailed on the Plans. For technical requirements, refer to the following sections provided in Part III Division 800:
 - **Section 08400 – Aluminum Entrance Doors and Framing**

8. Installation of the storefront glass windows and infill aluminum panels as detailed on the Plans. For technical requirements, refer to the following section provided in Part III Division 800:
 - **Section 08500 – Aluminum Windows**
 - **Section 08800 – Glass and Glazing**

800.3 Method of Measurement

The tunnel enclosures will be measured for payment as one lump sum unit, complete, and accepted.

The stair enclosure steel framing shall be shop-painted after fabrication as described in Section 506. Shop painting of structural steel and hardware for stair enclosures will be measured and paid for separately under Item 506.15 – Shop Coating of New Steel.

800.4 Basis of Payment

Payment will be made for work completed and accepted for tunnel enclosures at the Contract Lump Sum price. All labor and materials required will be incidental to this item.

Payment will be made under:

<u>Pay Item</u>	<u>Pay Unit</u>
800.40 Tunnel Stair Enclosures	Lump Sum

SPECIAL PROVISIONSECTION 800MISCELLANEOUS INCIDENTALS

(Metal Stairs at Tunnel Staircases)

800.1 Description

This work shall consist of designing, furnishing and installing industrial-type stair components, concrete infill, stair support framing and embedded steel plates and anchor assemblies for attaching steel to precast tunnel staircase units. All work shall be in accordance with these Specifications and in conformity with the locations and dimensions shown on the Plans. The stairs shall consist of steel treads, steel platforms and steel handrails attached to the concrete walls adjacent to the metal stairs.

Part III, Division 800 specifies materials, procedures and requirements for the design and construction of the metal stairs and support framing. Metal Stairs at Tunnel Staircases shall conform to the requirements provided in the following specifications:

- **Section 03300 – Cast-In-Place Concrete**
- **Section 05200 – Pipe and Tube Railings**
- **Section 05513 – Metal Pan Stairs**

800.2 Method of Measurement

The Metal Stairs will be measured for payment as one lump sum unit, complete, and accepted. Hot-dip galvanizing of structural steel and hardware for metal stairs and handrails will be measured and paid for separately under Item 506.9103 – Galvanizing.

800.3 Basis of Payment

The accepted quantity of Metal Stairs will be paid for at the contract lump sum price, which shall include all labor and materials required for the design, fabrication, delivery, and installation of the stair components, concrete infill, stair support framing and embedded steel plates and anchor assemblies for attaching steel to precast tunnel staircase segments. Shop drawing submittals shall be incidental to the Metal Stairs pay item.

No separate payment will be made for furnishing and installing the handrails located along the stairs.

Payment will be made under:

<u>Pay Item</u>	<u>Pay Unit</u>
800.503 Metal Stairs at Tunnel Staircases	Lump Sum

SPECIAL PROVISIONSECTION 801MISCELLANEOUS INCIDENTALS

(Test Pits)

801.01 Description

This work shall consist of excavating and back filling test holes to locate existing utilities at locations shown on the plans or as directed by the Resident.

801.02 Construction Requirements

The work shall be done in a manner that provides safe passage of the traveling public at all times. Coordination with the utilities is required prior and during the test pit activities. An authorized representative from the utility shall be present during the test pit activity. Test pits shall be completed in a manner that does not damage any utilities. Any damage to utilities or other roadway features by the test pit operations shall be repaired by the Contractor at no additional cost and shall be to the Resident's satisfaction.

Once the location work is complete, the Contractor shall backfill the hole, with material consistent with the existing conditions and in accordance with the standard specifications for backfilling.

801.03 Method of Measurement

Test Pits will be measured for payment by each.

801.04 Basis of Payment

The accepted quantity of Test Pits will be paid for at the contract unit price per vertical foot of excavation, which shall be full compensation for all labor, materials, tools, equipment, and incidentals necessary to the complete the work including excavation, backfilling, restoration, pavement replacement, disposal of materials and the protection of the utilities. Associated traffic control will not be paid for separately and is considered incidental to the test pit item.

Payment will be made under:

<u>Pay Item</u>	<u>Pay Unit</u>
801.03 Test Pits	Each

SPECIAL PROVISIONSECTION 801SANITARY SEWERS AND FORCE MAIN

(2 Inch Force Main)
(4" PVC Sanitary Sewer SDR 35)

The Provisions of Section 603 of the Standard Specifications shall apply with the following additions and modifications to reflect sanitary sewer constructions. The paragraph numbers have been revised from "603" to "801".

801.01 Description

This work shall consist of the construction of sewer pipes by means of trenched or trenchless installation, casing pipe, service leads, force mains hereinafter referred to as "pipe" as shown on the plans, details, and specified herein. The work includes furnishing and installing all necessary materials, labor, tools, fittings including tees, wyes, bends, adapters and couplings as required for a complete working sewer and service lateral.

The Contractor shall install locating/warning tape over the centerline of all sanitary sewer pipes including main lines, force mains, and service laterals. Both a green warning tape and a number 10 or 12 gauge single strand coated wire shall be installed at a maximum of 24 inches below finish surface grade for the entire length of the pipe. Magnetic warning tape may be used in place of the separate warning tape and wire.

All connections shall be made in conformance with the Maine State Plumbing Code.

801.02 Materials

Materials shall meet the requirements specified for the various subsections of the specifications and listed below:

Polyvinyl Chloride (PVC) SDR-35 Pipe: Pipe shall meet the following requirements.

1. PVC SDR-35 pipe shall be Ring Type Sewer Pipe SDR-35.
2. PVC SDR-35 pipe shall meet ASTM D3034 for sizes 4" thru 15".
3. PVC SDR-35 rubber seals shall meet ASTM D 3212.
4. All fittings and pipe shall have a water tight push on joint and must meet the ASTM D3034 and ASTM D3212 standards.
5. Minimum "pipe stiffness" at 4% deflection shall be 46 psi for all sizes when tested in accordance with ASTM D2421.
6. All fittings and connectors shall meet ASTM D3034 and ASTM D 3212 Standards.
7. Joints shall be push-on rubber gasketed "Bell and Spigot" type joints using factory installed elastomeric ring gaskets. The gaskets shall be securely fixed into place by the manufacturer so that they cannot be dislodged during joint assembly.

8. The gaskets shall be of a composition and texture that is resistant to common ingredients of storm sewer, including oils and groundwater, and that will permanently endure the conditions of the proposed use.
9. Acceptable Manufacturers include:
 - a. J-M Manufacturing
 - b. IPEX
 - c. Or equal to above

Backfill and Bedding Materials: Backfill and Bedding materials shall be as noted on the plans including:

- | | |
|---|---------------------|
| 1. Aggregate Base - Screened or Crushed | Stand. Spec. 703.06 |
| 2. Aggregate Subbase – Sand | Stand. Spec. 703.06 |
| 3. Crushed Stone for Pipe Bedding | Stand. Spec. 703.30 |
| 4. Crushed Stone (Overdepth) | Stand Spec. 703.31 |
| 5. Granular Borrow for Trench Backfill | Stand. Spec. 703.19 |

Pipe Insulation: Shall be 2” Thick Extruded Polystyrene Insulation conforming to AASHTO M 230.

801.03 Construction Requirements

801.031 Polyvinyl Chloride (PVC) Sewer Pipe and Fittings:

Each pipe length shall be inspected before being laid. Pipe shall be laid to conform to the lines and grades indicated on the drawings. Each pipe shall be so laid as to form a close joint with the next adjoining pipe and bring the inverts continuously to the required grade.

Bell holes shall be excavated or provided in the base material to receive the bell or coupling so that only the barrel of the pipe receives bearing pressure from the supporting material.

When each pipe has been properly bedded, enough of the backfill material shall be placed and compacted between the pipe and the sides of the trench to hold the pipe in correct alignment.

No pipe or fitting shall be permanently supported on blocks, wedges, boards or stones.

All joints shall be made in a dry trench and in accordance with the manufacturer's recommendations.

Pipe bundles shall be stored on a flat surface so as to support the barrels evenly. This is important as in hot weather PVC pipe will deflect or warp causing installing problems in line and grade. If a warped section is found, the Contractor shall not use such length of pipe.

In order to ensure proper compaction, alignment, and grade, and eliminate any construction problems that may be encountered, the Contractor shall be required to use only the 12-1/2 foot lengths of PVC pipe.

Pipe shall remain stacked in the original shipping bundles, and only pipe taken off the bundle for one day's laying shall be distributed along the trench.

PVC pipe will not bond to concrete or mortar and therefore connection to a cast-in-place or brick manhole and catch basin shall be made as shown on the pipe connection detail of the project plans.

801.032 Cleaning Inspection and Testing

Pipe may be inspected at the manufacturing plant, or on the work site and shall be subject to rejection at any time, even though sample pipe may have been accepted as satisfactory at the manufacturing plant.

All pipes shall be subject to thorough inspection and tests. All tests shall be made in accordance with the methods prescribed by, and the acceptance or rejections shall be based on, applicable ASTM specifications.

Pipe will be inspected upon delivery and all pipe which does not conform to the requirements of this contract will be rejected and shall be immediately removed from the work area by the Contractor.

Unsatisfactory pipe will be permanently rejected.

If such pipe is found in the pipeline, it shall be removed and replaced or encased in a Class A concrete collar or envelope as directed, at no additional cost to the City.

An inspection of the interior of all mainline pipe lateral connections installed as part of the project shall be completed prior to final paving.

801.033 Final Sanitary Sewer Testing

Work Included:

- a. Final storm and sanitary sewer testing work includes the performance of testing and inspecting each and every length of storm and sewer pipe, pipe joint and each item of appurtenant construction.
- b. Perform testing at a time acceptable to the Engineer, which may be during the construction operations, after completion of all pipe laying operations.
- c. Provide all labor and equipment and any other necessary apparatus for the testing.
- d. Provide a low pressure air test of the sanitary sewer line.

Execution:

- a. General:
 1. All sanitary sewers and appurtenant work, in order to be eligible for acceptance, shall be subjected to tests that will determine the degree of horizontal and vertical alignment.

2. Thoroughly clean and flush all sanitary sewer lines to be tested, prior to initiating test procedures.
 3. Perform all tests and inspections in the presence of the Engineer, or others assigned by the engineer, to ensure accuracy and compliance.
- b. Remedial Work:
1. Perform all work necessary to correct deficiencies discovered as a result of testing and or inspections.
 2. Completely retest all portions of the original construction on which remedial work has been performed.
- c. Alignment Tests:
1. Perform tests for the correctness of horizontal and vertical alignment on each and every length of gravity sewer pipeline between manholes.
 2. Alignment tests to be conducted after all pipe has been installed and backfilled.
 3. The observation test shall be conducted after all upstream work has been completed and the pipeline cleaned of debris.
 4. Notify the Engineer at least 24 hours in advance of the proposed observation testing.
 5. Beam a source of light, acceptable to the Engineer, through the pipeline from both ends and the Engineer will directly observe the light in the downstream, and/or upstream manhole of each test section.
 6. The length of pipe between manholes, diameter of pipe and amount of light observed in the manhole at the end of each pipe section will determine acceptance of the alignment test by the Engineer.
 7. The amount of vertical and horizontal deflection shall not be greater than the ASTM allowance and (manufacture's recommendations) for the pipe being tested.
 8. NO STANDING WATER SHALL BE ALLOWED. The presence of standing water shall be cause for rejection of that pipe (including manhole) section.
 9. Improper alignment will be corrected by re-excavation and resetting of pipe.
- d. Pipe Deflection:
1. Pipe provided under this specification shall be installed so there is no more than a maximum deflection of 5.0 percent. Such deflection shall be computed by multiplying the amount of deflection (normal diameter less minimum diameter when measured) by 100 and dividing by the nominal diameter of the pipe.
 2. The Contractor shall wait a minimum of 30 days after completion of a section of storm sewer, including placement and compaction of backfill, before measuring the amount of deflection by pulling a specially designed gage assembly through the completed section. The gage assembly shall be in accordance with the recommendations of the pipe manufacturer and be acceptable to the Engineer.
 3. Should the installed pipe fail to meet this requirement, the Contractor shall do all work to correct the problem as the Engineer may require without additional compensation.
- e. Television Inspection Tests (gravity storm and sanitary sewers)
1. Where television inspection testing is required, test procedures shall be in compliance with the requirements outlined in Specification Section.

2. No standing water shall be allowed. The presence of standing water may be cause for rejection of that pipe.
3. Any standing water, detectable leaks, improper joints or any other unacceptable feature detected by the television inspection will be corrected by re-excavation and resetting pipe at no additional cost to the owner.

801.04 Method of Measurement

Pipes and service laterals will be measured by the linear foot as measured along the centerline of the pipe. The linear foot price includes all fittings, couplings adapters, wyes tees bends no separate measurement will be made for these items.

For measurement purposes the end of the pipe in closed structures will be considered at the inside face of the wall, and in masonry headwalls it will be considered to be at least the face of the headwall.

Sewer pipe will be measured by the linear foot. The installation of new sewer pipe includes providing all tees, wyes, fittings caps and risers for a complete installation as shown on the drawings. The cost of fittings is incidental to the linear foot cost of the pipe and no separate measurement will be made. The location and elevation of the laterals shown on the plan are approximate. The final location will be coordinated in the field by the resident.

801.05 Basis of Payment

The accepted quantities of sewers/laterals will be paid for at the contract unit price per linear foot, complete in place. The linear foot price shall be full compensation for clearing, excavation (with the exception of structural rock excavation or structural earth excavation as ordered by the Resident), and saw cutting pavement. The linear foot price will include furnishing and installing all pipe, fittings, couplings, adapters, wyes and tees required for a complete installation.

Backfilling and compaction of all trench materials and furnishing and installing pipe bedding and special backfill as shown on the details is included in the linear foot price.

Excavated material meeting the specifications for Common Borrow may be used as trench backfill from 6" above the crown of the pipe to 4" below finished grade. Backfilling to bottom of loam and compaction of all trench materials and furnishing and installing pipe bedding and special backfill as shown on the details is included in the linear foot price. Furnishing and installing 4" of loam and seed shall be paid for under Section 615.

All dewatering, sheeting, shoring, or temporary bracing required for trench excavation and to support adjacent utilities or structures is incidental to this item and no separate payment will be made.

Saw cutting pavement for trench excavation shall be incidental to this item.

If any excavation including a utility trench is extended to a depth of more than fifteen (15) feet, it will be necessary to have the sideslopes or trench sheeting and shoring designed by a professional engineer licensed in the State of Maine. No extra payment will be made for the

engineered sheeting and shoring methods, materials or equipment used by the Contractor. All trench stabilization shall be considered incidental to the applicable pay items.

The costs for wyes, tees, adaptors, couplings bends, retainer glands and thrust blocking shall be incidental to the appropriate pipe item.

The cost of locating/warning tape including installation shall be considered incidental to the appropriate pipe item.

Payment will be made under:

<u>Pay Item</u>		<u>Pay Unit</u>
801.132	2 Inch Force Main	Linear Foot
801.141	4" PVC Sanitary Sewer (SDR-35)	Linear Foot

SPECIAL PROVISIONSECTION 802SUBSURFACE WASTEWATER SEPTIC SYSTEM

(Subsurface Wastewater Leach Field with Geotextile Sand Filter)
(1250 Gallon Precast Septic Tank with Pump)

802.01 Description

This work shall consist of construction of the subsurface wastewater septic tank, pump, controls, wiring and leach field. The leach field includes geotextile sand filter (GSF) produced by Eljen Corporation and associated components as indicated on the drawings and as contained in the HHE-200, Subsurface Wastewater Disposal System Application.

All connections shall be made in conformance with the Maine State Plumbing Code.

802.02 Materials

802.021 Subsurface Wastewater System Geotextile Sand Filter (GSF)

Subsurface Wastewater Geotextile Sand Filter shall be as manufactured by Eljen Corporation, no substitutions allowed.

802.022 Precast Concrete Septic Tank, Risers and Distribution Box

Precast concrete septic tank, risers and distribution box shall be as shown on the plans. Conform to the applicable requirements of ASTM C478. Concrete strength shall be 5,000 psi after 28 days. Wire fabric for reinforcement shall conform to the requirements of ASTM A185 and steel reinforcement shall conform to the requirements of ASTM A615 with a minimum yield stress of 40,000 psi.

Coat exterior of structures with Koppers Bitumastic 3000 m or equal.

The precast structures shall be designed for hydrostatic head equal to depth of the structure and shall be capable of withstanding an H- 20 truck load. The chamber shall be installed watertight.

802.023 Pumps and Rail Assembly

Lift station shall be a simplex lift station panel and controls for the operations of 0.5 HP Barnes effluent pump operating at approximately 43 GPM and 14.5 Ft THD. The pumps are model EHV412A, 1Phase, 60 Hz, 115 Volt, 3450 RPM and 6.4 FLA with the installed impeller.

All lift station piping shall be 2" Sch 80 PVC.

Rail Assembly: Arrange the pump and its check valve to allow easy removal, installation and adjustment without the necessity of personnel entering the chamber. Pumps shall have break

away fittings. Pumps to be installed with stainless steel guide rails with a Conery BER200 rail system.

802.024 Lift Station Pipe and Pipe Connections:

All lift station piping shall be 2" Sch 80 PVC.

Use pre-molded elastomeric sealed joints at the joints between the pipe (such as but not limited to influent sewer) Pre-molded elastomeric sealed joints shall be A-Lok, Res-Seal, Press-Wedge II, Lock Joints Flexible Manhole Sleeve, Kor-N-Seal Joint Sleeve, or equal.

For pipes (such as but not limited to discharge pipe, vent) installed submerged or below grade, the annular space shall be sealed watertight with mechanically expanded interlocking synthetic rubber links of the Link-Seal type, or equal. Nuts and bolts shall be zinc coated steel.

For pipes installed non-submerged or above grade, pack the annular space with jute and caulked flush at both ends with a polysulfide sealant.

802.025 Level Sensors and Electrical Components: Provide float type non-mercury switches, encapsulated within a solid polyurethane float ball. Provide level sensors with individual float weights to operate the pumps and to detect high water level in the basin addition. Provide a mounting bracket near the access opening to allow adjustment of the control and alarm levels. Furnish each non-mercury float switch with cable lengths to suit the installation without splices (control panel is remotely mounted). A properly rated electrical cable with a screwed, sealing type, cord-grip shall connect the switches to the electrical junction box. Float switches to be installed with Primex float switch connection system.

All underground electric power lines shall be installed in PVC conduit. Above ground services shall be installed in schedule 40 galvanized conduit. Sizes as required by electric company. All electrical wiring shall meet all State and NEC electrical code requirements.

Pump power/control cables and float cables shall be routed to the wet well in separate conduits with the proper expansion joints, seal offs, water-tight junction boxes with cord grips and expansion joints. Wire sizing and conduits feeding and leaving the control panel shall be properly sized, shall support the load of two pumps operating and meet all applicable State & NEC electrical codes.

802.026 Panel: The panel shall be equipped with an inner door that has an elapsed timed meter, warning lights/indicator lights for power, pump off, pump on, high water and alarm control switches for the (auto, off and run) and a control switch for the alarm with test and silence.

The panel shall have both a red visible alarm light and an audible piezo 80db alarm. The enclosure shall be a fiberglass NEMA 4x rated, UL508A compliant listed enclosure rated for the pumps with a wiring schematic provided on the inner face of the panel door. The door shall have a weather seal and lockable latches.

The panel shall have the required circuitry, controllers, circuit breakers, delays, motor starters, relays, terminal block and grounding required to operate the pump.

The panel shall be manufactured by Primex Controls or approved equivalent. The main breakers (control and pumps) and fuses for both the alarm and controls shall be accessible without opening the inner door.

802.027 Submittals:

The pumps, controls, floats and float rack shall be supplied by one distributor or manufacturer. Distributor or manufacturer supplying equipment shall confirm all equipment meets the intent of this specification, and that all equipment supplied is compatible for this specific application.

All equipment supplied requiring factory start-up to obtain warranty shall be included and performed by factory authorized personnel. Any deficiencies shall be addressed prior to final acceptance.

Contractor to confirm operating elevations with engineer before ordering station.

Contractor to submit specifications for pumps, control panels, and alarm for owner and Residents approval.

Electric services shall be verified by Contractor and coordinated with owner, electric company and pump station manufacturer prior to installation.

Contractor shall provide and install all electrical components required for pump station meeting applicable State and Federal codes.

Provide operation and maintenance manuals for all components.

802.03 Construction Requirements

Construction requirements for the geotextile sand filter (GSF) shall be as specified within the Eljen Corporation Geotextile Sand Filter, Maine Design and Installation Manual.

802.04 Method of Measurement

Subsurface wastewater geotextile sand filter shall be measured as a lump sum for the system installed and accepted.

1,250 gallon septic tank with pump shall be measured as a lump sum for the system installed and accepted including all excavation, backfill, precast concrete tank, risers, manhole covers, filter, pumps, rail system, lifting chains, floats, control panel and wiring and electrical work for a complete and functioning system.

802.05 Basis of Payment

The accepted quantity of the subsurface wastewater leach filed with geotextile sand filter shall be at the contract lump sum price. The lump sum price shall constitute full compensation for furnishing and installing all materials, excavating, laying GSF, furnishing and installing medium coarse sand and gravelly coarse sand fill, furnishing and installing a precast concrete

distribution box and piping from the box to the leach field, backfill, compaction, testing, and activating system. Lump sum price shall include all labor and materials necessary to satisfactorily install the subsurface wastewater Geotextile Sand Filter.

The accepted septic tank with pump shall be paid at the contract lump sum price. The lump price includes all submittals, coordination, excavation, backfill, precast concrete tank, risers, manhole covers, filter, pumps, rail system, lifting chains, floats, control panel and wiring and electrical work for a complete and functioning system.

Payment will be made under:

<u>Pay Item</u>	<u>Pay Unit</u>
802.23 Subsurface Wastewater Leach Field with Geotextile Sand Filter (GSF)	Lump Sum
802.241 1250 Gallon Precast Septic Tank with Pump	Lump Sum

SPECIAL PROVISIONSECTION 822WATER SUPPLY MAIN

(16" Ductile Iron Pipe)

822.01 Description

This work shall consist of construction of water supply main and associated fittings as indicated on the plans or as directed by the Resident.

822.02 Materials

All water supply main work, materials, and installation procedures shall adhere to the requirements and specifications stated within the York Water District Special Provisions – Water Main and Appurtenances, revised August 2018 or latest revision.

Refer to Appendix G for York Water District Special Provisions – Water Main and Appurtenances, Revised August 2018.

822.02 Timing of Construction

Contractor shall adhere to the requirements of the York Water District related to the timing of water main construction and for scheduling main shut downs required for the completion of the work. Such shut downs may be restricted to off-peak demand hours as determined by the York Water District.

Water main construct and testing shall be completed by March 1, 2019 unless otherwise approved by the York Water District.

822.03 Method of Measurement

Water supply main shall be measured by the linear foot as measured along the centerline of the pipe for the actual linear foot of pipe installed, including fittings such as sleeves, bends, tees, etc.

822.04 Basis of Payment

The accepted quantities for water supply main shall be paid for at the contract unit price per linear foot, which shall be full compensation for clearing, excavating (excluding rock excavation), shoring and bracing, dewatering, pipe, fittings, bedding, laying and jointing, testing, removing and disposing of existing pipe and appurtenances that are being replaced, connections to existing mains, backfilling, compaction, testing, aggregate subbase, aggregate base, and associated work as specified and shown on Drawings or as directed by the Resident. Where rock is encountered within the trench limits of the water main, separate measurement and payment will be made under Item 206.07 – Structural Rock Excavation – Drainage & Minor Structures. Payment for water main shall include all coordination of the work with the York Water District.

Any additional costs for night work or work outside of normal working hours that may be required by the Water District for off peak shutdowns is incidental to the work and no separate or additional payment shall be made.

Payment will be made under:

<u>Pay Item</u>	<u>Pay Unit</u>
822.37 16" Ductile Iron Pipe	Linear Foot

SPECIAL PROVISIONSECTION 822WATER METER PIT

(Water Meter Pit)

822.01 Description

This work shall consist of installation of the water meter pit and associated service connections as indicated on the drawings.

822.02 Materials

Materials shall meet the requirements specified in the following Sections of Division 700 – Materials:

Portland Cement	701.01
Reinforcing Steel	709.01
Precast Concrete Units	712.06

Except as otherwise provided on the plans, concrete for these structures shall meet the requirements of Section 502 – Structural Concrete.

822.03 Construction Requirements

Water Meter Pit shall be constructed of precast units. Joints between precast sections shall be sealed with mastic joint filler to form a watertight joint. All openings in the concrete for service piping shall be sealed with a modular seal.

Meter pit shall be at least 48-inches in diameter with an opening at least 30-inches in diameter with a cast iron frame.

822.04 Method of Measurement

Water meter pit will be measured as one lump sum, complete in place.

822.05 Basis of Payment

Water Meter Pit will be paid for at the Contract Lump Sum price which shall be full compensation for supplying all materials, equipment and labor to satisfactorily complete the work and making all necessary and required water service connections in accordance with the York Water District standards and requirements.

Payment will be made under:

Pay Item

Pay Unit

822.60

Water Meter Pit

Lump Sum

SPECIAL PROVISION

SECTION 823

WATER SUPPLY APPURTENANCES

(1" Air Release Valve)
(16" Gate Valve)

823.01 Description

This work shall consist of construction of water supply main appurtenances as indicated on the plans or as directed by the Resident.

823.02 Materials

All water supply main work, materials, and installation procedures shall adhere to the requirements and specifications stated within the York Water District Special Provisions – Water Main and Appurtenances, revised August 2018 or latest revision.

Refer to Appendix G for York Water District Special Provisions – Water Main and Appurtenances, Revised August 2018.

823.03 Method of Measurement

Air release valves and gate valves shall be measured by each for the actual number of valves installed and accepted.

823.04 Basis of Payment

The accepted quantities for air release valves and gate valves shall be paid for at the contract unit price per each, which shall be full compensation for excavation, shoring and bracing, dewatering, valve, pipe and sleeves for cut-in valves, valve box, backfill, compaction, testing, aggregate subbase, aggregate base, base course bituminous pavement, surface course bituminous pavement, cleanup, and associated work as specified and shown on Drawings.

Payment will be made under:

<u>Pay Item</u>		<u>Pay Unit</u>
823.3411	1" Air Release Valve	Each
823.374	16" Gate Valve	Each

SPECIAL PROVISIONSECTION 832BOLLARD

(Type A Steel Bollard)

832.01 Description

This work shall consist of furnishing and installation of Type A Steel Site Bollards with cast in place concrete base and LDPE bollard sleeves in accordance with these Specifications, and as shown on the Plans or as approved by the Resident.

832.02 Materials

Bollards shall 6" Diameter Schedule 40 steel tube as shown on the plans,

Concrete shall be Class "A" cement concrete (4000 PSI). Reinforcing steel shall meet the requirements of Section 503.

Bollard Sleeve shall be ¼" thick Low Density Polythene

832.03 General

LDPE sleeve shall be a minimum ¼" thick, pre manufactured bollard sleeve, color Osha Safety Yellow.

832.04 Method of Measurement

Bollards will be measured by each unit complete and in place.

832.05 Basis of Payment

The accepted quantity of bollards will be paid for at the Contract unit price each which payment shall be full compensation for furnishing and installing bollards, bollard sleeves, concrete base and bollard infill, excavation, backfill, compaction, tools, equipment, labor and all incidentals necessary to complete the work.

Payment will be made under:

<u>Pay Item</u>	<u>Pay Unit</u>
832.41 Type A Steel Site Bollard	Each

MAINE TURNPIKE AUTHORITY
MAINE TURNPIKE

PART III – DIVISION 800

CONTRACT 2018.20

YORK TOLL PLAZA
MILE 8.8

DIVISION 800
TABLE OF CONTENTS

The specification sections listed below, and all State of Maine Department of Transportation “Standard Specifications for Highways and Bridges” referenced therein, comprise Division 800:

3 - CONCRETE

03300 Cast-in-Place Concrete.....03300 1 to 18

4 - MASONRY

04050 Unit Masonry, General.....04050 1 to 11
04100 Masonry Mortar and Grout04100 1 to 3
04150 Masonry Accessories04150 1 to 4
04210 Brick Masonry04210 1 to 2
04220 Concrete Masonry Units04220 1 to 3

5 - METALS

05100 Structural Steel Framing05100 1 to 9
05200 Pipe and Tube Railings05200 1 to 6
05210 Steel Joist Framing.....05210 1 to 4
05310 Steel Decking05310 1 to 5
05500 Metal Fabrications05500 1 to 8
05513 Metal Pan Stairs05513 1 to 7
05531 Bar Grating.....05531 1 to 4

6 – WOOD AND PLASTICS

06100 Rough Carpentry.....06100 1 to 6
06175 Shop-Fabricated Wood Trusses06175 1 to 6
06400 Finish Carpentry.....06400 1 to 4

7 – THERMAL AND MOISTURE PROTECTION

07200 Insulation.....07200 1 to 4
07531 Ethylene-Propylene-Diene-Monomer (EDPM) Roofing.....07531 1 to 7
07600 Flashing and Sheet Metal.....07600 1 to 2

07610	Metal Roofing	07610	1 to 13
07720	Roof Hatches (Tunnel Access Hatch).....	07720	1 to 3
07841	Penetration Firestopping	07841	1 to 8
07900	Joint Sealers	07900	1 to 6

8 – DOORS AND WINDOWS

08110	Steel Doors and Frames	08110	1 to 7
08400	Aluminum Entrance Doors and Framing.....	08400	1 to 5
08500	Aluminum Windows.....	08500	1 to 3
08700	Finish Hardware.....	08700	1 to 6
08800	Glass and Glazing	08800	1 to 5
08900	Operable Wall Louvers	08900	1 to 5

9 - FINISHES

09211	Gypsum Board Shaft Wall Assemblies.....	09211	1 to 4
09250	Gypsum Drywall.....	09250	1 to 6
09300	Ceramic Tile.....	09300	1 to 3
09500	Suspended Ceilings.....	09500	1 to 2
09650	Resilient Wall Base and Accessories.....	09650	1 to 3
09900	Painting	09900	1 to 15

10 - SPECIALTIES

10142	Room-Identification Signage	10142	1 to 5
10200	Miscellaneous	10200	1 to 4
10211	Phenolic-Core Toilet Compartments	10211	1 to 5
10520	Fire Extinguisher.....	10520	1 to 2
10600	Toilet Accessories.....	10600	1 to 2

11 – KITCHEN EQUIPMENT

11460	Kitchen Equipment	11460	1 to 2
-------	-------------------------	-------	--------

12 – KITCHEN CASEWORK

12356	Kitchen Casework.....	12356	1 to 6
-------	-----------------------	-------	--------

15 - MECHANICAL

15000	Supplemental General Mechanical Requirements	15000	1 to 8
15070	Vibration and Seismic Controls for HVAC	15070	1 to 8
15071	Hangers and Supports for HVAC Piping and Equipment	15071	1 to 8
15110	Ball Valves for HVAC Piping	15110	1 to 3
15120	Expansion Fittings and Loops for HVAC Piping	15120	1 to 5
15130	Hydronic Pumps.....	15130	1 to 4
15180	Hydronic Piping	15180	1 to 8
15181	Refrigerant Piping.....	15181	1 to 11
15185	Hydronic Piping Specialties.....	15185	1 to 5
15190	Underground Hydronic Piping.....	15190	1 to 7
15250	Insulation.....	15250	1 to 6
15400	Plumbing.....	15400	1 to 42
15500	Fire Protection System.....	15500	1 to 9
15600	Hot Water Boilers	15600	1 to 8
15610	Fan Coil Units	15610	1 to 6
15620	Propeller Unit Heaters.....	15620	1 to 5
15630	Cabinet Unit Heaters.....	15630	1 to 8
15640	Baseboard Radiation Heaters	15640	1 to 3
15700	Common Motor Requirements for HVAC Equipment.....	15700	1 to 3
15720	Modular Indoor Central-Station Air-Handling Units	15720	1 to 14
15730	Split-System Heat Pumps	15730	1 to 6
15740	Computer Room Air Conditioners Ceiling Mounted Units.....	15740	1 to 6
15800	Ductwork and Accessories.....	15800	1 to 6
15830	HVAC Power Ventilators	15830	1 to 6
15840	Air Terminal Units.....	15840	1 to 7
15850	Diffusers, Registers, and Grilles	15850	1 to 3
15860	Breechings, Boiler Stack & Chimney.....	15860	1 to 3
15870	Radon Mitigation	15870	1 to 4
15890	HVAC Water Treatment.....	15890	1 to 7
15920	Direct Digital Control (DDC) System for HVAC	15920	1 to 97
15950	Testing, Adjusting, and Balancing for HVAC.....	15950	1 to 18

15955	Commissioning of HVAC.....	15955	1 to 9
15990	Sequence of Operations for HVAC DDC.....	15990	1 to 9

16 - ELECTRICAL

16050	Hangers and Supports for Electrical Systems.....	16050	1 to 4
16051	Sleeves and Sleeve Seals for Electrical Raceways and Cabling..	16051	1 to 4
16052	Identification for Electrical Systems.....	16052	1 to 6
16110	Raceways and Boxes for Electrical Systems	16110	1 to 11
16111	Underground Ducts and Raceways for Electrical Systems.....	16111	1 to 6
16120	Low-Voltage Electrical Power Conductors and Cables.....	16120	1 to 5
16130	Wiring Devices	16130	1 to 7
16131	Wiring Specialties – Heat Tracing.....	16131	1 to 3
16287	Surge Protection for Low-Voltage Electrical Power Circuits.....	16287	1 to 4
16375	Electrical Metering.....	16375	1 to 2
16410	Transfer Switches.....	16410	1 to 9
16450	Grounding and Bonding for Electrical Systems	16450	1 to 7
16461	Low-Voltage Transformers.....	16461	1 to 5
16472	Panelboards	16472	1 to 7
16510	LED Interior Lighting	16510	1 to 6
16511	Emergency and Exit Lighting	16511	1 to 4
16512	Lighting Control Devices.....	16512	1 to 9
16520	LED Exterior Lighting	16520	1 to 7
16601	Lightning Protection for Structures	16601	1 to 3
16621	Engine Generators.....	16621	1 to 14
16723	Digital, Addressable Fire-Alarm System.....	16723	1 to 14
16800	Telecommunication Cabling.....	16800	1 to 11
16825	Telecommunications Equipment	16825	1 to 10

SECTION 03300CAST-IN-PLACE CONCRETE

PART 1 - GENERAL

1.1 RELATED DOCUMENTS

- A. Examine Drawings, Contract Conditions all other Sections of the Specifications for requirements which affect work of this Section whether or not such work is specifically mentioned in this Section.
- B. Coordinate work with that of all other trades affecting, or affected by work of this Section. Cooperate with such trades to assure the steady progress of all Project work.

1.2 DESCRIPTION

- A. Section includes cast-in-place concrete, including formwork, reinforcement, concrete materials, mixture design, placement procedures, and finishes at the Toll Administration Building only. Requirements for site concrete adjacent to the Toll Administration Building, concrete ORT slabs and concrete within the toll plaza are provided under the MassDOT Standard Specifications, MTA Supplemental Specifications, and the Special Provisions for this Project.
- B. Related Requirements:
 - 1. Structural Steel Framing – Section 05100
 - 2. Metal Fabrications – Section 05500
 - 3. Joint Sealers - Section 07900

1.3 DEFINITIONS

- A. Cementitious Materials: Portland cement alone or in combination with one or more of the following: blended hydraulic cement, fly ash, slag cement, other pozzolans, and silica fume; materials subject to compliance with requirements.
- B. W/C Ratio: The ratio by weight of water to cementitious materials.

1.4 PREINSTALLATION MEETINGS

- A. Pre-installation Conference: Conduct conference at the Project site.
 - 1. Before submitting design mixtures, review concrete design mixture and examine procedures for ensuring quality of concrete materials. Require representatives of

each entity directly concerned with cast-in-place concrete to attend, including the following:

- a. Contractor's superintendent.
 - b. Independent testing agency responsible for concrete design mixtures.
 - c. Ready-mix concrete manufacturer.
 - d. Concrete Subcontractor.
2. Review testing and inspecting agency procedures for field quality control, concrete finishes and finishing, cold- and hot-weather concreting procedures, curing procedures, construction contraction and isolation joints, and joint-filler strips, semirigid joint fillers, forms and form removal limitations, shoring and reshoring procedures, vapor-retarder installation, anchor rod and anchorage device installation tolerances, steel reinforcement installation, methods for achieving specified floor and slab flatness and levelness, floor and slab flatness and levelness measurement, concrete repair procedures, and concrete protection.

1.5 SUBMITTALS

- A. Product Data: Submit manufacturer's product data with application and installation instructions for proprietary materials and items, including the following:
1. Cementitious materials.
 2. Admixtures.
 3. Form materials and form-release agents.
 4. Steel reinforcement and accessories.
 5. Waterstops.
 6. Curing compounds.
 7. Floor and slab treatments.
 8. Bonding agents.
 9. Adhesives.
 10. Vapor retarders.
 11. Joint-filler strips.
 12. Repair materials.
- B. Design Mixtures: For each concrete mixture. Submit alternate design mixtures when characteristics of materials, Project conditions, weather, test results, or other circumstances warrant adjustments.
1. Indicate amounts of mixing water to be withheld for later addition at Project site.
- C. Steel Reinforcement Shop Drawings: Placing Drawings that detail fabrication, bending, and placement. Include bar sizes, lengths, material, grade, bar schedules, stirrup spacing, bent bar diagrams, bar arrangement, splices and laps, mechanical connections, tie spacing, hoop spacing, and supports for concrete reinforcement.
- D. Construction Joint Layout: Indicate construction joints required to construct the structure.

1. Where locations of construction joints are not shown on the Drawings, construction joint layouts are subject to approval by the Engineer.

E. Samples: For waterstops and vapor retarders.

1.6 INFORMATIONAL SUBMITTALS

A. Qualification Data: For installer, manufacturer, and testing agency.

B. Material Test Reports: For the following, from a qualified testing agency:

1. **Aggregates:** Include service record data indicating absence of deleterious expansion of concrete due to alkali aggregate reactivity.

C. Formwork Shop Drawings: Prepared by or under the supervision of a qualified professional engineer licensed to practice in the State of Maine, detailing fabrication, assembly, and support of formwork.

1. **Shoring and Reshoring:** Indicate proposed schedule and sequence of stripping formwork, shoring removal, and reshoring installation and removal.

D. Field quality-control reports.

E. Minutes of preinstallation conference.

1.7 QUALITY ASSURANCE

A. **Installer Qualifications:** A qualified installer who employs on Project personnel qualified as ACI-certified Flatwork Technician and Finisher and a supervisor who is an ACI-certified Concrete Flatwork Technician.

B. **Manufacturer Qualifications:** A firm experienced in manufacturing ready-mixed concrete products and that complies with ASTM C 94/C 94M requirements for production facilities and equipment.

1. Manufacturer certified according to NRMCA's "Certification of Ready Mixed Concrete Production Facilities."

C. **Testing Agency Qualifications:** An independent agency, acceptable to the Maine Turnpike Authority, and qualified according to ASTM C 1077 and ASTM E 329 for testing indicated.

1. Personnel conducting field tests shall be qualified as ACI Concrete Field Testing Technician, Grade 1, according to ACI CP-1 or an equivalent certification program.
2. Personnel performing laboratory tests shall be ACI-certified Concrete Strength Testing Technician and Concrete Laboratory Testing Technician, Grade I.

Testing agency laboratory supervisor shall be an ACI-certified Concrete Laboratory Testing Technician, Grade II.

1.8 PRECONSTRUCTION TESTING

- A. Preconstruction Testing Service: Engage a qualified testing agency to perform preconstruction testing on concrete mixtures.

1.9 DELIVERY, STORAGE, AND HANDLING

- A. Steel Reinforcement: Deliver, store, and handle steel reinforcement to prevent bending and damage. Avoid damaging coatings on steel reinforcement.
- B. Waterstops: Store waterstops under cover to protect from moisture, sunlight, dirt, oil, and other contaminants.

1.10 FIELD CONDITIONS

- A. Cold-Weather Placement: Comply with ACI 306.1 and as follows. Protect concrete work from physical damage or reduced strength that could be caused by frost, freezing actions, or low temperatures.
 - 1. When average high and low temperature is expected to fall below 40 deg F (4.4 deg C) for three successive days, maintain delivered concrete mixture temperature within the temperature range required by ACI 301.
 - 2. Do not use frozen materials or materials containing ice or snow. Do not place concrete on frozen subgrade or on subgrade containing frozen materials.
 - 3. Do not use calcium chloride, salt, or other materials containing antifreeze agents or chemical accelerators unless otherwise specified and approved in mixture designs.
- B. Hot-Weather Placement: Comply with ACI 301 and as follows:
 - 1. Maintain concrete temperature below 90 deg F (32 deg C) at time of placement. Chilled mixing water or chopped ice may be used to control temperature, provided water equivalent of ice is calculated to total amount of mixing water. Using liquid nitrogen to cool concrete is Contractor's option.
 - 2. Fog-spray forms, steel reinforcement, and subgrade just before placing concrete. Keep subgrade uniformly moist without standing water, soft spots, or dry areas.

PART 2 - MATERIALS

2.1 CONCRETE, GENERAL

- A. ACI Publications: Comply with the following unless modified by requirements in the Contract Documents:

1. ACI 301
2. ACI 117

2.2 FORM-FACING MATERIALS

- A. Smooth-Formed Finished Concrete: Form-facing panels that provide continuous, true, and smooth concrete surfaces. Furnish in largest practicable sizes to minimize number of joints.
 1. Plywood, metal, or other approved panel materials.
 2. Overlaid Finnish birch plywood.
- B. Chamfer Strips: Wood, metal, PVC, or rubber strips with chamfer dimensions as specified on the Drawings. Provide minimum dimensions of 3/4 by 3/4 inch (19 by 19 mm).
- C. Form-Release Agent: Commercially formulated form-release agent that does not bond with, stain, or adversely affect concrete surfaces and does not impair subsequent treatments of concrete surfaces.
 1. Formulate form-release agent with rust inhibitor for steel form-facing materials.
- D. Form Ties: Factory-fabricated, removable or snap-off glass-fiber-reinforced plastic or metal form ties designed to resist lateral pressure of fresh concrete on forms and to prevent spalling of concrete on removal.
 1. Furnish units that leave no corrodible metal closer than 1 inch (25 mm) to the plane of exposed concrete surface.
 2. Furnish ties that, when removed, leave holes no larger than 1 inch (25 mm) in diameter in concrete surface.
 3. Furnish ties with integral water-barrier plates to walls indicated to receive dampproofing or waterproofing.

2.3 STEEL REINFORCEMENT

- A. Reinforcing Bars: ASTM A 615/A 615M, Grade 60, deformed.
- B. Plain-Steel Welded-Wire Reinforcement: ASTM A 1064/A 1064M, plain, fabricated from as-drawn steel wire into flat sheets.

2.4 REINFORCEMENT ACCESSORIES

- A. Joint Diamond Dowel Plates: Plates manufactured from steel meeting ASTM A36 requirements.
- B. Joint Dowel Bars: ASTM A 615/A 615M, Grade 60 (Grade 420), plain-steel bars, cut true to length with ends square and free of burrs.

- C. Bar Supports: Bolsters, chairs, spacers, and other devices for spacing, supporting, and fastening reinforcing bars and welded-wire reinforcement in place. Manufacture bar supports from steel wire, plastic, or precast concrete according to CRSI's "Manual of Standard Practice," of greater compressive strength than concrete and as follows:
1. For concrete surfaces exposed to view, where legs of wire bar supports contact forms, use CRSI Class 1 plastic-protected steel wire or CRSI Class 2 stainless-steel bar supports.

2.5 CONCRETE MATERIALS

- A. Source Limitations: Obtain each type or class of cementitious material of the same brand from the same manufacturer's plant, obtain aggregate from single source, and obtain admixtures from single source from single manufacturer.
- B. Cementitious Materials:
1. Portland Cement: ASTM C 150/C 150M, Type I or II unless otherwise acceptable to the Engineer.
- C. Normal-Weight Aggregates: ASTM C 33/C 33M, coarse aggregate or better, graded. Provide aggregates from a single source.
1. Maximum Coarse-Aggregate Size:
 - a. Footings and Walls: 3/4 inch
 - b. Concrete Floor Slab, Slabs-on-Grade, and Sump Pit: 3/8 inch
- D. Air-Entraining Admixture: ASTM C 260/C 260M.
- E. Chemical Admixtures: Certified by manufacturer to be compatible with other admixtures and not containing more than 1% chloride ions. Do not use calcium chloride or admixtures containing calcium chloride.
1. Water-Reducing Admixture: ASTM C 494/C 494M, Type A.
 2. Retarding Admixture: ASTM C 494/C 494M, Type B.
 3. High-Range, Water-Reducing Admixture: ASTM C 494/C 494M, Type F.
 4. High-Range, Water-Reducing and Retarding Admixture: ASTM C 494/C 494M, Type G.
- F. Corrosion-Inhibiting Admixture: Commercially formulated, anodic inhibitor or mixed cathodic and anodic inhibitor; capable of forming a protective barrier and minimizing chloride reactions with steel reinforcement in concrete and complying with ASTM C 494/C 494M, Type C. Provide DCI Corrosion Inhibitor manufactured by Grace, or approved equal.
- G. Water: ASTM C 94/C 94M and potable.

2.6 WATERSTOPS

- A. Flexible Rubber Waterstops: CE CRD-C 513 for embedding in concrete to prevent passage of fluids through joints. Factory fabricate corners, intersections, and directional changes.
 - 1. Profile: Flat dumbbell with center bulb.
 - 2. Dimensions: 4 inches by 3/16 inch thick, nontapered.

2.7 SOIL GAS/VAPOR RETARDERS

- A. Sheet Vapor Retarder: ASTM E 1745, Class A. Include manufacturer's recommended adhesive or pressure-sensitive tape.

2.8 CURING MATERIALS

- A. Absorptive Cover: AASHTO M 182, Class 2, burlap cloth made from jute or kenaf, weighing approximately 9 oz./sq. yd. when dry.
- B. Moisture-Retaining Cover: ASTM C 171, polyethylene film or white burlap-polyethylene sheet.
- C. Water: Potable.
- D. Clear, Waterborne, Membrane-Forming Curing Compound: ASTM C 309, Type 1, Class B.

2.9 RELATED MATERIALS

- A. Expansion- and Isolation-Joint-Filler Strips: ASTM D 1751, asphalt-saturated cellulosic fiber or ASTM D 1752, cork or self-expanding cork.
- B. Bonding Agent: ASTM C 1059/C 1059M, Type II, nonredispersible, acrylic emulsion or styrene butadiene.
- C. Epoxy Bonding Adhesive: ASTM C 881, two-component epoxy resin, capable of humid curing and bonding to damp surfaces, of class suitable for application temperature and of grade to suit requirements, and as follows:

2.10 CONCRETE MIXTURES, GENERAL

- A. Prepare design mixtures for each type and strength of concrete, proportioned on the basis of laboratory trial mixture or field test data, or both, according to ACI 301.
 - 1. Use a qualified independent testing agency for preparing and reporting proposed mixture designs based on laboratory trial mixtures. The testing facility shall not be the same as used for the field quality control testing unless otherwise acceptable to the Engineer.

2. Submit written reports to the Engineer for each proposed mix design at least 14 days prior to the start of work. Do not begin concrete production until mixes have been reviewed and approved by the Engineer.

- B. Admixtures: Use admixtures acceptable to the Engineer according to manufacturer's written instructions.
 1. Use corrosion-inhibiting admixture in concrete mixtures as specified herein.

2.11 CONCRETE MIXTURES FOR BUILDING ELEMENTS

- A. Footings and Walls: Normal-weight concrete.
 1. Minimum Compressive Strength: 4000 psi at 28 days, 3/4 inch aggregate.
 2. Maximum W/C Ratio: 0.45
 3. Slump Limit: 3 inches plus or minus 1 inch.
 4. Air Content: 4% to 6%.
- B. Concrete Floor Slab, Slabs-on-Grade and Sump Pit: Normal-weight concrete.
 1. Minimum Compressive Strength: 4000 psi at 28 days, 3/8 inch aggregate.
 2. Maximum W/C Ratio: 0.45
 3. Slump Limit: 3 inches plus or minus 1 inch.
 4. Air Content: 4% to 6%.

2.12 FABRICATING REINFORCEMENT

- A. Fabricate steel reinforcement according to CRSI's "Manual of Standard Practice."

2.13 CONCRETE MIXING

- A. Ready-Mixed Concrete: Measure, batch, mix, and deliver concrete according to ASTM C 94/C 94M, and furnish batch ticket information.
 1. When air temperature is between 85 and 90 deg F, reduce mixing and delivery time from 1-1/2 hours to 75 minutes; when air temperature is above 90 deg F, reduce mixing and delivery time to 60 minutes.

PART 3 - EXECUTION

3.1 FORMWORK INSTALLATION

- A. Design, erect, shore, brace, and maintain formwork, according to ACI 301, to support vertical, lateral, static, and dynamic loads, and construction loads that might be applied, until structure can support such loads.
- B. Construct formwork so concrete members and structures are of size, shape, alignment, elevation, and position indicated, within tolerance limits of ACI 117.

- C. Construct forms tight enough to prevent loss of concrete mortar.
- D. Construct forms for easy removal without hammering or prying against concrete surfaces. Provide crush or wrecking plates where stripping may damage cast-concrete surfaces. Provide top forms for inclined surfaces steeper than 1.5 horizontal to 1 vertical.
 - 1. Install keyways, reglets, recesses, and the like, for easy removal.
 - 2. Do not use rust-stained steel form-facing material.
- E. Set edge forms, bulkheads, and intermediate screed strips for slabs to achieve required elevations and slopes in finished concrete surfaces. Provide and secure units to support screed strips; use strike-off templates or compacting-type screeds.
- F. Provide temporary openings for cleanouts and inspection ports where interior area of formwork is inaccessible. Close openings with panels tightly fitted to forms and securely braced to prevent loss of concrete mortar. Locate temporary openings in forms at inconspicuous locations.
- G. Chamfer exterior corners and edges of permanently exposed concrete as specified on the Drawings.
- H. Clean forms and adjacent surfaces to receive concrete. Remove chips, wood, sawdust, dirt, and other debris just before placing concrete.
- I. Retighten forms and bracing before placing concrete, as required, to prevent mortar leaks and maintain proper alignment.
- J. Coat contact surfaces of forms with form-release agent, according to manufacturer's written instructions, before placing reinforcement.

3.2 EMBEDDED ITEM INSTALLATION

- A. Place and secure anchorage devices and other embedded items required for adjoining work that is attached to or supported by cast-in-place concrete. Use setting drawings, templates, diagrams, instructions, and directions furnished with items to be embedded.
 - 1. Install and accurately locate all anchor rods, embedded plates with shear studs, railing post pipe sleeves, and all other embedded items. Install embedded items to elevations required and complying with tolerances in Section 7.5 of AISC 303.

3.3 REMOVING AND REUSING FORMS

- A. General: Formwork for sides of walls and similar parts of the Work that does not support weight of concrete may be removed after cumulatively curing at not less than 50 deg F for 24 hours after placing concrete. Concrete has to be hard enough to not be damaged by form-removal operations, and curing and protection operations need to be maintained.

1. Remove forms only if shores have been arranged to permit removal of forms without loosening or disturbing shores.
- B. Thoroughly clean and repair surfaces of forms to be reused in the Work. Split, frayed, delaminated, or otherwise damaged form-facing material are not acceptable for exposed surfaces. Apply new form-release agent.
- C. When forms are reused, clean surfaces, remove fins and laitance, and tighten to close joints. Align and secure joints to avoid offsets. Do not use patched forms for exposed concrete surfaces unless approved by Engineer.

3.4 SHORING AND RESHORING INSTALLATION

- A. Comply with ACI 318 and ACI 301 for design, installation, and removal of shoring and reshoring.
 1. Do not remove shoring or reshoring until measurement of slab tolerances is complete.
- B. Plan sequence of removal of shores and reshore to avoid damage to concrete. Locate and provide adequate reshoring to support construction without excessive stress or deflection.

3.5 VAPOR/GAS-RETARDER INSTALLATION

- A. Sheet Vapor Retarders: Place, protect, and repair sheet vapor retarder according to ASTM E 1643 and manufacturer's written instructions.
 1. Lap joints 12 inches and seal with manufacturer's recommended tape.

3.6 STEEL REINFORCEMENT INSTALLATION

- A. General: Comply with CRSI's "Manual of Standard Practice" for fabricating, placing, and supporting reinforcement.
 1. Do not cut or puncture vapor retarder. Repair damage and reseal vapor retarder before placing concrete.
- B. Clean reinforcement of loose rust and mill scale, earth, ice, and other foreign materials that reduce bond to concrete.
- C. Accurately position, support, and secure reinforcement against displacement. Locate and support reinforcement with bar supports to maintain minimum concrete cover. Do not tack weld crossing reinforcing bars.
- D. Set wire ties with ends directed into concrete, not toward exposed concrete surfaces.
- E. Install welded-wire reinforcement in longest practicable lengths on bar supports spaced to minimize sagging. Lap edges and ends of adjoining sheets at least one mesh spacing.

Offset laps of adjoining sheet widths to prevent continuous laps in either direction. Lace overlaps with wire.

3.7 JOINTS

- A. General: Construct joints true to line with faces perpendicular to surface plane of concrete.
- B. Construction Joints: Install so strength and appearance of concrete are not impaired, at locations indicated on the Drawings or as approved by Engineer.
 - 1. Place joints perpendicular to main reinforcement. Continue reinforcement across construction joints unless otherwise indicated.
 - 2. Form keyed joints as indicated on the Drawings. Embed keys a minimum of 1-1/2 inches into concrete.
 - 3. Use epoxy-bonding adhesive at locations where fresh concrete is placed against hardened or partially hardened concrete surfaces.
- C. Contraction Joints in Slabs-on-Grade: Form weakened-plane contraction joints, sectioning concrete into areas as indicated on the Drawings.
- D. Isolation Joints in Slabs-on-Grade: After removing formwork, install joint-filler strips at slab junctions with vertical surfaces as indicated on the Drawings.
- E. Joint Fillers: Terminate full-width joint-filler strips not less than 1/2 inch or more than 1 inch below finished concrete surface where joint sealants, specified in Section 07900 - Joint Sealers, are indicated.
- F. Doweled Joints: Install dowel plates and support assemblies at joints where indicated. Lubricate or asphalt coat one-half of dowel length to prevent concrete bonding to one side of joint.

3.8 WATERSTOP INSTALLATION

- A. Flexible Waterstops: Install in construction joints and at other joints indicated to form a continuous diaphragm. Install in longest lengths practicable. Support and protect exposed waterstops during progress of the Work. Field fabricate joints in waterstops according to manufacturer's written instructions.

3.9 CONCRETE PLACEMENT

- A. Before placing concrete, verify that installation of formwork, reinforcement, and embedded items is complete. Provide 48 hour notice to the Engineer for required inspections prior to placing concrete.
- B. Do not add water to concrete during delivery, at Project site, or during placement unless approved by Engineer.

- C. Before test sampling and placing concrete, water may be added at Project site, subject to limitations of ACI 301.
1. Do not add water to concrete after adding high-range water-reducing admixtures to mixture.
- D. Deposit concrete continuously in one layer or in horizontal layers of such thickness that no new concrete is placed on concrete that has hardened enough to cause seams or planes of weakness. If a section cannot be placed continuously, provide construction joints as indicated. Deposit concrete to avoid segregation.
1. Deposit concrete in horizontal layers of depth not to exceed formwork design pressures and in a manner to avoid inclined construction joints.
 2. Consolidate placed concrete with mechanical vibrating equipment according to ACI 301.
 3. Do not use vibrators to transport concrete inside forms. Insert and withdraw vibrators vertically at uniformly spaced locations to rapidly penetrate placed layer and at least 6 inches into preceding layer. Do not insert vibrators into lower layers of concrete that have begun to lose plasticity. At each insertion, limit duration of vibration to time necessary to consolidate concrete and complete embedment of reinforcement and other embedded items without causing mixture constituents to segregate.
- E. Deposit and consolidate concrete for floors and slabs in a continuous operation, within limits of construction joints, until placement of a panel or section is complete.
1. Consolidate concrete during placement operations, so concrete is thoroughly worked around reinforcement and other embedded items and into corners.
 2. Maintain reinforcement in position on chairs during concrete placement.
 3. Screed slab surfaces with a straightedge and strike off to correct elevations.
 4. Slope surfaces uniformly to drains where required.
 5. Begin initial floating using bull floats or darbies to form a uniform and open-textured surface plane, before excess bleedwater appears on the surface. Do not further disturb slab surfaces before starting finishing operations.

3.10 FINISHING FORMED SURFACES

- A. Rough-Formed Finish: As-cast concrete texture imparted by form-facing material with tie holes and defects repaired and patched. Remove fins and other projections that exceed specified limits on formed-surface irregularities.
1. Apply to all concrete surfaces excluding walls.
- B. Smooth-Formed Finish: As-cast concrete texture imparted by form-facing material, arranged in an orderly and symmetrical manner with a minimum of seams. Repair and patch tie holes and defects. Remove fins and other projections that exceed specified limits on formed-surface irregularities.
1. Apply to concrete wall surfaces.

- C. Rubbed Finish: Apply the following to smooth-formed-finished as-cast concrete where indicated:
1. Grout-Cleaned Finish: Wet concrete surfaces and apply grout of a consistency of thick paint to coat surfaces and fill small holes. Mix 1 part portland cement to 1-1/2 parts fine sand with a 1:1 mixture of bonding admixture and water. Add white portland cement in amounts determined by trial patches, so color of dry grout matches adjacent surfaces. Scrub grout into voids and remove excess grout. When grout whitens, rub surface with clean burlap and keep surface damp by fog spray for at least 36 hours.
- D. Related Unformed Surfaces: At tops of walls, horizontal offsets, and similar unformed surfaces adjacent to formed surfaces, strike off smooth and finish with a texture matching adjacent formed surfaces. Continue final surface treatment of formed surfaces uniformly across adjacent unformed surfaces unless otherwise indicated.

3.11 FINISHING FLOORS AND SLABS

- A. General: Comply with ACI 302.1R recommendations for screeding, restraightening, and finishing operations for concrete surfaces. Do not wet concrete surfaces. Finish the concrete slab-on-grade at the basement level and first floor concrete slab with one of the methods listed below.
1. Scratch Finish: While still plastic, texture concrete surface that has been screeded and bull-floated or darbied. Use stiff brushes, brooms, or rakes to produce a profile amplitude of 1/4 inch in one direction.
 2. Float Finish: Consolidate surface with power-driven floats or by hand floating if area is small or inaccessible to power-driven floats. Restraighten, cut down high spots, and fill low spots. Repeat float passes and restraightening until surface is left with a uniform, smooth, granular texture.
 3. Trowel Finish: After applying float finish, apply first troweling and consolidate concrete by hand or power-driven trowel. Continue troweling passes and restraighten until surface is free of trowel marks and uniform in texture and appearance. Grind smooth any surface defects that would telegraph through applied coatings or floor coverings.
 4. Finish and measure surface, so gap at any point between concrete surface and an unlevelled, freestanding, 10-ft. long straightedge resting on two high spots and placed anywhere on the surface does not exceed 3/16 inch.

3.12 MISCELLANEOUS CONCRETE ITEM INSTALLATION

- A. Filling In: Fill in holes and openings left in concrete structures after work of other trades is in place unless otherwise indicated. Mix, place, and cure concrete, as specified, to blend with in-place construction. Provide other miscellaneous concrete filling indicated or required to complete the Work.
- B. Steel Pan Stairs: Provide concrete fill for steel pan stair treads, landings, and associated items. Screed, tamp, and trowel finish concrete surfaces.

3.13 CONCRETE PROTECTING AND CURING

- A. General: Protect freshly placed concrete from premature drying and excessive cold or hot temperatures. Comply with ACI 306.1 for cold-weather protection and ACI 301 for hot-weather protection during curing.
- B. Evaporation Retarder: Apply evaporation retarder to unformed concrete surfaces if hot, dry, or windy conditions cause moisture loss approaching 0.2 lb/sq. ft. x h before and during finishing operations. Apply according to manufacturer's written instructions after placing, screeding, and bull floating or darbying concrete, but before float finishing.
- C. Formed Surfaces: Cure formed concrete surfaces, including underside of beams, supported slabs, and other similar surfaces. If forms remain during curing period, moist cure after loosening forms. If removing forms before end of curing period, continue curing for remainder of curing period.
- D. Unformed Surfaces: Begin curing immediately after finishing concrete. Cure unformed surfaces, including floors and slabs, concrete floor toppings, and other surfaces.
- E. Cure concrete according to ACI 308.1, by one or a combination of the following methods:
 - 1. Moisture Curing: Keep surfaces continuously moist for not less than seven days with the following materials:
 - a. Water.
 - b. Continuous water-fog spray.
 - c. Absorptive cover, water saturated, and kept continuously wet. Cover concrete surfaces and edges with 12-inch lap over adjacent absorptive covers.
 - 2. Moisture-Retaining-Cover Curing: Cover concrete surfaces with moisture-retaining cover for curing concrete, placed in widest practicable width, with sides and ends lapped at least 12 inches, and sealed by waterproof tape or adhesive. Cure for not less than seven days. Immediately repair any holes or tears during curing period, using cover material and waterproof tape.
 - a. Moisture cure or use moisture-retaining covers to cure concrete surfaces to receive floor coverings.
 - b. Moisture cure or use moisture-retaining covers to cure concrete surfaces to receive penetrating liquid floor treatments.
 - c. Cure concrete surfaces to receive floor coverings with either a moisture-retaining cover or a curing compound that the manufacturer certifies does not interfere with bonding of floor covering used on Project.
 - 3. Curing Compound on Slabs: Apply uniformly in continuous operation by power spray or roller according to manufacturer's written instructions. Recoat areas subjected to heavy rainfall within three hours after initial application. Maintain continuity of coating and repair damage during curing period.

- a. Removal: After curing period has elapsed, remove curing compound without damaging concrete surfaces by method recommended by curing compound manufacturer unless manufacturer certifies curing compound does not interfere with bonding of floor covering used on Project.
4. Curing and Sealing Compound: Apply uniformly to slab-on-grade indicated in a continuous operation by power spray or roller according to manufacturer's written instructions. Recoat areas subjected to heavy rainfall within three hours after initial application. Repeat process 24 hours later and apply a second coat.

3.14 LIQUID FLOOR TREATMENT APPLICATION

- A. Penetrating Liquid Floor Treatment: Prepare, apply, and finish penetrating liquid floor treatment according to manufacturer's written instructions.
 1. Remove curing compounds, sealers, oil, dirt, laitance, and other contaminants and complete surface repairs.
 2. Do not apply to concrete that is less than seven days' old.
 3. Apply liquid until surface is saturated, scrubbing into surface until a gel forms; rewet; and repeat brooming or scrubbing. Rinse with water; remove excess material until surface is dry. Apply a second coat in a similar manner if surface is rough or porous.

3.15 JOINT FILLING

- A. Prepare, clean, and install joint filler according to manufacturer's written instructions.
 1. Defer joint filling until concrete has aged at least one month(s). Do not fill joints until construction traffic has permanently ceased.
- B. Remove dirt, debris, saw cuttings, curing compounds, and sealers from joints; leave contact faces of joints clean and dry.

3.16 CONCRETE SURFACE REPAIRS

- A. Defective Concrete: Repair and patch defective areas when approved by Engineer. Remove and replace concrete that cannot be repaired and patched to Engineer's approval.
- B. Patching Mortar: Mix dry-pack patching mortar, consisting of 1 part portland cement to 2-1/2 parts fine aggregate passing a No. 16 sieve, using only enough water for handling and placing.
- C. Repairing Formed Surfaces: Surface defects include color and texture irregularities, cracks, spalls, air bubbles, honeycombs, rock pockets, fins and other projections on the surface, and stains and other discolorations that cannot be removed by cleaning.

1. Immediately after form removal, cut out honeycombs, rock pockets, and voids more than 1/2 inch in any dimension to solid concrete. Limit cut depth to 3/4 inch. Make edges of cuts perpendicular to concrete surface. Clean, dampen with water, and brush-coat holes and voids with bonding agent. Fill and compact with patching mortar before bonding agent has dried. Fill form-tie voids with patching mortar or cone plugs secured in place with bonding agent.
 2. Repair defects on surfaces exposed to view by blending white portland cement and standard portland cement so that, when dry, patching mortar matches surrounding color. Patch a test area at inconspicuous locations to verify mixture and color match before proceeding with patching. Compact mortar in place and strike off slightly higher than surrounding surface.
 3. Repair defects on concealed formed surfaces that affect concrete's durability and structural performance as determined by Engineer.
- D. Repairing Unformed Surfaces: Test unformed surfaces, such as floors and slabs, for finish and verify surface tolerances specified for each surface. Correct low and high areas. Test surfaces sloped to drain for trueness of slope and smoothness; use a sloped template.
1. Repair finished surfaces containing defects. Surface defects include spalls, popouts, honeycombs, rock pockets, crazing and cracks in excess of 0.01 inch wide or that penetrate to reinforcement or completely through unreinforced sections regardless of width, and other objectionable conditions.
 2. After concrete has cured at least 14 days, correct high areas by grinding.
 3. Correct localized low areas during or immediately after completing surface finishing operations by cutting out low areas and replacing with patching mortar. Finish repaired areas to blend into adjacent concrete.
 4. Correct other low areas scheduled to receive floor coverings with a repair underlayment. Prepare, mix, and apply repair underlayment and primer according to manufacturer's written instructions to produce a smooth, uniform, plane, and level surface. Feather edges to match adjacent floor elevations.
 5. Correct other low areas scheduled to remain exposed with a repair topping. Cut out low areas to ensure a minimum repair topping depth of 1/4 inch to match adjacent floor elevations. Prepare, mix, and apply repair topping and primer according to manufacturer's written instructions to produce a smooth, uniform, plane, and level surface.
 6. Repair defective areas, except random cracks and single holes 1 inch or less in diameter, by cutting out and replacing with fresh concrete. Remove defective areas with clean, square cuts and expose steel reinforcement with at least a 3/4-inch clearance all around. Dampen concrete surfaces in contact with patching concrete and apply bonding agent. Mix patching concrete of same materials and mixture as original concrete, except without coarse aggregate. Place, compact, and finish to blend with adjacent finished concrete. Cure in same manner as adjacent concrete.
 7. Repair random cracks and single holes 1 inch or less in diameter with patching mortar. Groove top of cracks and cut out holes to sound concrete and clean off dust, dirt, and loose particles. Dampen cleaned concrete surfaces and apply bonding agent. Place patching mortar before bonding agent has dried. Compact

patching mortar and finish to match adjacent concrete. Keep patched area continuously moist for at least 72 hours.

- E. Perform structural repairs of concrete, subject to Engineer's approval, using epoxy adhesive and patching mortar.
- F. Repair materials and installation not specified above may be used, subject to Engineer's approval.

3.17 FIELD QUALITY CONTROL

- A. Testing Agency: Engage a qualified testing and inspecting agency to perform tests and inspections and to submit reports. Concrete testing shall be performed by technicians certified by the Maine Concrete Technician Certification Board.
- B. Concrete Tests: Testing of composite samples of fresh concrete obtained according to ASTM C 172/C 172M shall be performed according to the following requirements:
 - 1. Testing Frequency: Obtain at least one composite sample for each 100 cu. yd. or fraction thereof of each concrete mixture placed each day.
 - a. When frequency of testing provides fewer than five compressive-strength tests for each concrete mixture, testing shall be conducted from at least five randomly selected batches or from each batch if fewer than five are used.
 - 2. Slump: ASTM C 143/C 143M; one test at point of placement for each composite sample, but not less than one test for each day's pour of each concrete mixture. Perform additional tests when concrete consistency appears to change.
 - 3. Air Content: ASTM C 231/C 231M, pressure method, for normal-weight concrete; one test for each composite sample, but not less than one test for each day's pour of each concrete mixture.
 - 4. Concrete Temperature: ASTM C 1064/C 1064M; one test hourly when air temperature is 40 deg F and below or 80 deg F and above, and one test for each composite sample.
 - 5. Compression Test Specimens: ASTM C 31/C 31M.
 - a. Cast and laboratory cure two sets of two standard cylinder specimens for each composite sample.
 - b. Cast and field cure two sets of two standard cylinder specimens for each composite sample.
 - 6. Compressive-Strength Tests: ASTM C 39/C 39M
 - a. Laboratory-Cured Specimen Tests: Test one set of two laboratory-cured specimens at 7 days and one set of two specimens at 28 days.
 - b. Field-Cured Specimen Tests: Test one set of two field-cured specimens at 7 days and one set of two field-cured specimens at 28 days.
 - c. A compressive-strength test shall be the average compressive strength from a set of two specimens obtained from same composite sample and tested at age indicated.

7. When strength of field-cured cylinders is less than 85 percent of companion laboratory-cured cylinders, Contractor shall evaluate operations and provide corrective procedures for protecting and curing in-place concrete.
8. Strength of each concrete mixture will be satisfactory if every average of any three consecutive compressive-strength tests equals or exceeds specified compressive strength and no compressive-strength test value falls below specified compressive strength by more than 500 psi.
9. Test results shall be reported in writing to Engineer, concrete manufacturer, and Contractor within 48 hours of testing. Reports of compressive-strength tests shall contain Project identification name and number, date of concrete placement, name of concrete testing and inspecting agency, location of concrete batch in Work, design compressive strength at 28 days, concrete mixture proportions and materials, compressive breaking strength, and type of break for both 7- and 28-day tests.
10. Nondestructive Testing: Impact hammer, sonoscope, or other nondestructive device may be permitted by Engineer but will not be used as sole basis for approval or rejection of concrete.
11. Additional Tests: Testing and inspecting agency shall make additional tests of concrete when test results indicate that slump, air entrainment, compressive strengths, or other requirements have not been met, as directed by Engineer. Testing and inspecting agency may conduct tests to determine adequacy of concrete by cored cylinders complying with ASTM C 42/C 42M or by other methods as directed by Engineer.
12. Additional testing and inspecting, at Contractor's expense, will be performed to determine compliance of replaced or additional work with specified requirements.
13. Correct deficiencies in the Work that test reports and inspections indicate do not comply with the Contract Documents.

3.18 PROTECTION OF LIQUID FLOOR TREATMENTS

- A. Protect liquid floor treatment from damage and wear during the remainder of construction period. Use protective methods and materials, including temporary covering, recommended in writing by liquid floor treatments installer.

3.19 ENGINEER'S REVIEW

- A. The Engineer of Record will conduct periodic reviews of the construction for compliance with the provisions of the Design Documents during the construction period.
- B. The General Contractor shall employ a professional engineer, licensed to practice in the State of Maine, to analyze and design modifications and repairs for construction not in conformance with the provisions of the Contract Documents. These modifications and repair details shall be stamped by the professional engineer and submitted with calculations for approval by the Engineer of Record. Modifications shall not be made without express written approval.

END OF SECTION

SECTION 04050UNIT MASONRY, GENERAL

PART 1 – GENERAL

1.1 RELATED DOCUMENTS

- A. Drawings, Contract Conditions all other Technical Specifications Sections apply to work of this Section insofar as applicable.
- B. Coordinate work with that of all other trades affecting, or affected by work of this Section. Cooperate with such trades to assure the steady progress of all Project work.

1.2 DESCRIPTION

- A. The location of each type of unit masonry work is shown on the Drawings. In general, the work includes the following:
 - 1. CMU walls and applied weatherproofing.
 - 2. Brick facing and precast concrete sills.
 - 3. All ties, reinforcement and anchors required for securing all masonry work together and to adjacent work, except as otherwise specified.
 - 4. All through-wall metal and fabric flashing.
 - 5. Rigid cavity wall insulation and loose fill CMU insulation.
 - 6. Setting and/or building in all flashing, frames, windows, blocking, loose steel lintels, plates, anchors, bolts, ties, sleeves, door and frame, access doors, and all other items requiring building into work of this section.
 - 7. Cutting and patching of work in this section as required for the work of other sections.
 - 8. Cleaning and pointing.
 - 9. Submission of samples and shop drawings as specified or otherwise requested by the Engineer.
 - 10. Construction of one sample masonry panel for each type of masonry to be used, for Engineer's approval. Each panel will measure approximately 4'-0" x 4'-0".
- B. Related Requirements:
 - 1. Masonry Mortar and Grout are specified in Section 04100.
 - 2. Masonry Accessories are specified in Section 04150.
 - 3. Brick Masonry is specified in Section 04210.
 - 4. Concrete Masonry Units are specified in Section 04220.

1.3 QUALITY ASSURANCE

A. Comply with provisions of following codes, specifications and standards, except as otherwise indicated.

1. "BIA Technical Notes on Brick Construction", except as herein modified.
2. "Building Code Requirements for Engineered Brick Masonry" from the "BIA Technical Notes".
3. ACI 531 "Building Code Requirements for Concrete Masonry Structures".
4. ACI 531.1 "Specification for Concrete Masonry Construction".
5. ANSI/NBS H74 (A41.2) "Building Code Requirements for Reinforced Masonry".
6. ANSI/NBS 211 (A41.1) "Building Code Requirements for Masonry".

Where provisions of above codes and standards conflict with building regulations in effect for this Project, the building regulations will govern, but only to establish minimum requirements.

B. Coordination:

Review installation procedures and coordinate with other work that must be integrated with masonry.

C. Test for Masonry Materials:

Test prisms of materials in accordance with ASTM Standard E 447. The fully grouted prism strength shall be greater than 2700 psi.

Not less than three specimens shall be made for each initial preliminary test.

Not less than three shall be made for each field test to confirm that the materials are as assumed in the design. The standard age of test specimens shall be 28 days, but seven-day tests may be used provided the relationship between the seven-day and 28-day strengths of the masonry is established by adequate data for the materials used.

Make at least three field tests during construction. Test specimen for grout shall be field formed in accordance with UBC Standard No. 24-22 (NCMA TEK 23A). The compressive strength of grout shall be determined by testing field formed specimen in a damp condition in accordance with applicable provisions of ASTM C 39.

D. Construction Tolerances:

1. Variation from Plumb: For vertical lines and surfaces of columns, walls and arises do not exceed 1/4 inch in 10 feet or one story.

2. Variation from Level: For lines of exposed lintels, sills, parapets, horizontal grooves and other conspicuous lines, do not exceed 1/4 inch in any bay or 20 feet maximum, nor 3/4 inch in 40 feet or more.
3. Variation of Linear Building Line: For position shown in plan and related portion of columns, walls and partitions, do not exceed 1/2 inch in any bay or 20 feet maximum, nor 3/4 inch in 40 feet or more.
4. Variation in Cross-Sectional Dimensions: For columns and thickness of walls do not exceed minus 1/4 inch nor plus 1/2 inch from dimensions shown.

E. Job Mock-Up:

Prior to installation of masonry work, erect a sample wall panel mock-up using materials, bond and joint tooling required for final work. Provide special features as directed for sealant and contiguous work. Build mock-up at the site, where directed, parallel to finished wall of the building, of full thickness and approximately 4 feet long by 4 feet high, indicating the proposed range of color, texture and workmanship to be expected in the completed work, as well as sealants, flashing, insulation, ties, reinforcing, etc. Obtain the Engineer's acceptance of visual qualities of the mock-up before start of masonry work. Retain mock-up during construction as a standard for judging completed masonry work. Do not alter, move or destroy mock-up until work is completed.

1.4 JOB CONDITIONS

A. Materials Protection:

Protect masonry materials during storage and construction from wetting by rain, snow or groundwater and from soiling or inter-mixture with earth and other materials.

Do not use metal reinforcing or ties having loose rust or other coatings, including ice, which will reduce or destroy bond.

Protect grout and mortar materials from deterioration by moisture and temperature. Store in a dry location or in waterproof containers. Keep containers tightly closed and away from open flames. Protect liquid components from freezing. Comply with manufacturer's recommendations for minimum and maximum temperature requirements for storage.

B. Protection of Work:

During erection, cover top of wall with heavy waterproof sheeting at end of each day's work. Cover partially completed structures when work is not in progress. Extend cover a minimum of 24 inches down both sides and hold cover securely in place. Protect base of walls from rain-splashed mud and mortar splatter by means of coverings spread on ground and over wall surface.

Do not apply uniform floor or roof loading for at least 12 hours after building masonry walls or columns. Do not apply concentrated loads for at least 3 days after building masonry walls or columns.

Prevent grout or mortar from staining the face of masonry to be left exposed or painted. Immediately remove grout and mortar in contact with such masonry. Protect sills, ledges and projections from droppings of mortar and other materials.

Take special care to keep the cavity between unit masonry wythe and backup material free of buildup which will act as a bridge for water penetration through the wall construction. Constant monitoring of this area shall be required to ensure that the bottom of the cavity does not fill with mortar droppings and that there is no mortar or other buildup between face wythe and backup construction. Method for preventing mortar droppings within the cavity shall be demonstrated for, and approved by, the Engineer.

Cold-Weather Requirements: Do not use frozen materials or materials mixed or coated with ice or frost. Do not build on frozen substrates. Remove and replace unit masonry damaged by frost or by freezing conditions. Comply with cold-weather construction requirements contained in TMS 602/ACI 530.1/ASCE 6.

Cold-Weather Cleaning: Use liquid cleaning methods only when air temperature is 40 deg F and higher and will remain so until masonry has dried, but not less than seven days after completing cleaning.

Hot-Weather Requirements: Comply with hot-weather construction requirements contained in TMS 602/ACI 530.1/ASCE 6.

D. Procedures Required During Construction:

Perform the following construction procedures while the work is progressing. When the outside temperature falls below 40°F during construction the temperature of the mortar shall be within a range of 70°F and a maximum of 120°F after all ingredients have been combined. The following construction requirements shall be followed to obtain the required mortar temperature.

When the outside air temperature is:

- From 40°F to 32°F: Heat mixing water or sand to a minimum of 70°F and a maximum of 160°F.
- From 32°F to 25°F: Heat sand and water to a minimum of 70°F and a maximum of 160°F, maintain temperature of mortar on boards above freezing.
- 25°F and below: Heat sand and mixing water to a minimum of 70°F and maximum of 160°F; provide enclosures and auxiliary heat

to maintain air temperature above 32°F; do not lay units which have a temperature of less than 20°F. Units shall be heated to about 40°F to prevent sudden cooling of the heated mortar.

E. Procedures Required for Completed Masonry:

Perform the following for protection of completed masonry and masonry not being worked on.

When mean daily air temperature is:

From 40°F to 32°F: Protect masonry from rain or snow for at least 48 hours by covering with weather-resistive membrane.

From 32°F to 25°F: Completely cover masonry with weather-resistive membrane for at least 48 hours.

25°F and below: Maintain masonry temperature above 32°F for 48 hours using enclosures and supplementary heat, electric heating blankets, infrared lamps, or other acceptable methods.

PART 2 - MATERIALS

2.1 GENERAL

Refer to other sections of Division 4 for required masonry mortar, grout, masonry accessories, masonry units, face brick, and installation methods.

PART 3 - EXECUTION

3.1 INSPECTION:

Contractor must examine the areas and conditions under which unit masonry work is to be installed and notify the Authority's representative in writing of conditions detrimental to the proper and timely completion of the work. Do not proceed with the work until unsatisfactory conditions have been corrected in an acceptable manner.

3.2 PREPARATION

Except for absorbent units specified to be wetted by the manufacturer and approved by the Engineer, lay masonry units surface dry and adjust mortar mix to conform to the degree of water absorption for the individual masonry unit. Do not wet concrete masonry units. Use wetting methods which ensure that each masonry unit (except concrete masonry units) is nearly saturated but surface dry when laid.

3.3 INSTALLATION, GENERAL

Build cavity walls, composite walls, and other masonry construction to the full thicknesses shown. Build single-wythe walls to the actual thickness of the masonry units, using units of nominal thickness indicated.

Build chases and recesses as shown or required for the work of other trades. Unless otherwise shown, provide not less than 8 inches of masonry between chase or recess and jamb of openings, and between adjacent chases and recesses.

Leave openings for equipment to be installed before completion of masonry work. After installation of equipment, complete masonry work to match work immediately adjacent to the opening.

Cut masonry units using appropriate motor-driven masonry saws to provide clean, sharp, un-chipped edges. Cut units as required to provide pattern shown and to fit adjoining work neatly. Use full-size units without cutting wherever possible.

3.4 LAYING MASONRY WALLS

A. Mortar Types:

1. Unless otherwise indicated, use mortar as specified in Section 04100, "Masonry Mortar and Grout".

B. Batch Control:

1. Measure and batch materials by weight such that the required proportions for mortar can be accurately controlled and maintained. It is recommended that all batch materials be prepackaged to ensure consistency of proportions in the mortar mix. Measurement of sand by shovel will not be permitted.
2. Mix mortars with the minimum amount of water consistent with workability to provide maximum bond strength of the mortar.
3. Do not use mortar which has begun to set or if more than 2 hours has elapsed since initial mixing. Re-temper mortar during the 2 hour period only as required to restore workability.

C. Alignment:

1. Layout walls in advance for accurate spacing of surface bond patterns with uniform joint widths and to properly locate openings, movement-type joints, returns and offsets. Avoid the use of less-than-half-size units at corners, jambs and wherever possible at other locations.
2. Lay-up walls plumb and true to comply with specified tolerances, with courses level, accurately spaced and coordinated with other work.

D. Pattern Bond:

1. Lay exposed masonry in the bond patterns indicated. Lay concealed masonry with all units in a wythe in running bond. Bond and interlock each course of each wythe at corners. Do not use units with less than 4 inch horizontal face dimensions at corners or jambs.

E. Mortar Bedding and Jointing:

1. To ensure that the cavities of walls are kept clean from mortar droppings, all bed joints adjacent to the cavity shall be beveled.
2. Lay solid brick size masonry units with completely filled bed and head joints; butter ends with sufficient mortar to fill head joints and shove into place. Do not slush head joints.
3. Lay solid concrete masonry units greater than 4" in thickness with divided bed joints unless full bedding indicated. Keep drainage channels (if any) free of mortar. Form head joints with sufficient mortar so that excess will be squeezed out as units are shoved into position. Butter both sides of units to be placed, or butter one side of unit-in-place and one side of unit-to-be-placed.
4. Lay hollow concrete masonry units with full mortar coverage on horizontal and vertical faces of shells. Bed webs in mortar in starting course on footings and in all courses of piers, columns and pilasters, and where adjacent to cells or cavities to be reinforced or filled with concrete or grout.
5. Maintain joint widths shown, except for minor variations required to maintain bond alignment. If not shown, lay walls with 3/8 inch joints. Rake out mortar in preparation for application of sealants where shown and directed.
6. Cut joints flush for masonry walls which are to be concealed or to be covered by other materials, unless otherwise indicated.
7. Tool exposed joints slightly concave unless otherwise indicated.
8. Remove masonry units disturbed after laying; clean and reset in fresh mortar. Do not pound corners to fit stretcher units which have been set in position. If adjustments are required, remove units, clean off mortar and reset in fresh mortar.

E. Collar Joints:

1. Where shown, fill the vertical longitudinal joint between wythes solidly with mortar by parging the in-place wythe and shoving units into the parging.

F. Stopping and Resuming Work:

1. Rack back 1/2-unit length in each course; do not tooth. Clean exposed surfaces of set masonry, wet units lightly (if required) and remove loose masonry units and mortar prior to laying fresh masonry.

G. Built-in Work:

1. As the work progresses, "build-in" items specified under this and other sections of these specifications. Fill in solidly with masonry around built-in

items.

2. Fill space between hollow metal frames and masonry solid with mortar.
3. Where built-in items are to be embedded in cores of hollow masonry units, place a layer of metal screen lath in the joint two courses below the affected cell or cells, and rod grout into cores for four courses.

H. Grouting:

1. Do not place grout until entire height of masonry to be grouted has attained enough strength to resist grout pressure.
 - a. Comply with requirements in TMS 602/ACI 530.1/ASCE 6 for cleanouts and for grout placement, including minimum grout space and maximum pour height.
 - b. Limit height of vertical grout pours to not more than 60 inches.

I. Horizontal Joint Reinforcing:

2. Refer to Section 04150 "Masonry Accessories" for type of materials required.
3. Provide continuous horizontal joint reinforcing as shown and specified. Fully embed longitudinal side rods in mortar for their entire length with a minimum cover of 5/8 inch on exterior side of walls and 1/2 inch on interior side of walls. Lap reinforcement a minimum of 6 inches at ends of units. Do not bridge control and expansion joints with reinforcing.
4. In single-wythe and multi-wythe walls (solid or cavity) where continuous horizontal reinforcing also acts as structural bond or tie between wythes, space reinforcing as required by code but not more than 16 inches on center vertically.
5. Reinforce masonry openings greater than 1'-0" wide, with horizontal joint reinforcing placed in 2 horizontal joints approximately 8 inches apart, immediately above the lintel and immediately below the sill. Extend reinforcing a minimum at 2'-0" beyond jambs of the opening, bridging control joints only where indicated.

I. Corners:

1. Provide interlocking masonry unit bond in each course at corners, unless otherwise shown.
2. For horizontally reinforced masonry, provide continuity at corners with prefabricated "L" units, in addition to masonry bonding.

J. Intersecting and Abutting Walls:

1. Unless vertical expansion or control joints are shown at juncture, provide same type of bonding specified for structural bonding between wythes and provide continuity with horizontal joint reinforcing using prefabricated "T" units.

K. Intersecting Load-bearing Walls:

1. If carried up separately, provide rigid steel anchors at not more than 2'-0" on center vertically. Form anchors of galvanized steel not less than 1- 1/2" x 1/4" x 2'-0" long with ends turned up not less than 2 inches or with cross-pins. If used with hollow masonry units, embed ends in mortar-filled cells.

L. Cavity Walls:

1. Keep cavity clean of mortar droppings and other materials during construction. Strike joints facing cavity flush.
2. Tie exterior wythe to back-up with truss type ties embedded in mortar joints. Refer to Section 04150 "Masonry Accessories" for type of ties required.

M. Anchoring Masonry Work:

1. Provide anchoring devices of the type shown and as specified under Section 04150 "Masonry Accessories". If not shown or specified, assume that anchoring devices are required and request a clarification from the Engineer before commencing masonry work.
2. Anchor masonry to structural members where masonry abuts or faces such members to comply with the following:
 - a. Provide an open space not less than 1 inch in width between masonry and structural member, unless otherwise shown. Keep open space free of mortar and other rigid materials.
 - b. Anchor masonry to structural members with metal ties embedded in masonry joints and attached to structure. Provide anchors with flexible tie sections, unless otherwise shown.

N. Expansion Joints for Exterior Brick Masonry:

1. Provide vertical expansion and isolation joints in brick masonry where shown. Build-in related items as the masonry work progresses. Refer to Section 07900, Joint Sealers.

O. Control Joints for Concrete Masonry Units:

1. Consult the Engineer for the location of control joints.

P. Lintels:

1. Provide steel lintels where shown, in accordance with Section 05500, Metal Fabrications.
2. Provide concrete masonry unit reinforced bond beams where shown on the Drawings in accordance with Section 04220 – Concrete Masonry Units.
3. Provide minimum bearing at each jamb of 4 inches for openings less than 6'-0" wide; 8 inches for wider openings.

Q. Flashing of Masonry Work:

1. Provide concealed flashings in masonry work at obstructions to the downward flow of water in the wall so as to divert such water to the exterior. Concealed flashings shall be provided at, but not be limited to, the following locations:
 - a. Wall base, continuous and above finish grade.
 - b. Window sills.
 - c. Above steel lintels, relief angles and shelf angles.
 - d. Projections, recesses and caps.
 - e. Top of walls.
2. Prepare masonry surfaces to be smooth and free from projections which could puncture flashing. Seal penetrations in flashing with approved mastic. Extend flashings the full length of lintels and shelf angles and minimum of 4 inches into masonry at each end. Extend flashing from 4 inches beyond exterior face of masonry, through the outer wythe, turned up a minimum of 4 inches, and through the inner wythe to within 1/2 inch of the interior face of the wall in exposed work. Where interior surface of inner wythe is concealed by furring, carry flashing completely through the inner wythe and turn up approximately 2 inches and adhere to face of interior wythe.
3. Where inter-backup is other than masonry, install flashing to conform to profile of shelf angle and extend a minimum of 8 inches up (and adhere to) the backup material.
4. Lap ends of flashings by overlapping a minimum of 6 inches and seal lap with mastic recommended by manufacturer.
5. Provide 8 inch high end dams at the termination of all non-continuous flashings. Also provide continuous vertical flashings at all wall openings.
6. Install elastic flashings in accordance with manufacturer's instructions.
7. Provide prefabricated PVC honeycomb weep joint inserts in the head joints of the first course of masonry immediately above all concealed flashings. Space 24 inches on center, unless otherwise indicated. Provide 1/4 inch diameter cotton rope weeps, returned 12 inches up back-up wall. Take care not to cover weeps with sealant or mortar.
8. Install nailers for flashing and other related work where shown to be built into masonry work.

3.5 REPAIR, POINTING AND CLEANING

- A. Remove and replace masonry units which are loose, chipped, broken, stained or otherwise damaged, or if units do not match adjoining units as intended. Provide

new units to match adjoining units and install in fresh mortar or grout, pointed to eliminate evidence of replacement.

B. Pointing:

During the tooling of joints, enlarge voids and holes, except weep holes, and completely fill with mortar.

Point-up all joints including corners, openings and adjacent work to provide a neat, uniform appearance, and where required, properly prepared for application of sealant.

C. Cleaning Exposed, Unglazed Masonry Surfaces:

Wipe off excess mortar as the work progresses. Dry brush at the end of each day's work.

D. Final Cleaning:

After mortar is thoroughly set and cured, clean 1/2 of sample wall panel as follows. Obtain Engineer's acceptance of sample cleaning before proceeding to clean masonry work.

Dry clean to remove large particles of mortar using wood paddles and scrapers. Use chisel or wire brush if required and approved.

Presoak wall by saturating with water and flush off loose mortar and dirt. Scrub down wall with stiff bristle brushes and water mixed with the appropriate amount of one of the following masonry cleaners:

1. Vana-trol by Prosoco Inc.
2. Light duty Concrete Cleaner by Prosoco Inc.

Rinse walls using clean, pressurized water, to neutralize cleaning solution and remove loose material. Acid cleaning of masonry will not be permitted.

Protect non-masonry surfaces from damage as necessary during cleaning operations. Restore all items so damaged to a like-new condition acceptable to the Engineer at no additional cost.

E. Protection:

Protect the masonry work from deterioration, discoloration and other damage during subsequent construction operations.

END OF SECTION

SECTION 04100

MASONRY MORTAR AND GROUT

PART 1 - GENERAL

1.1 RELATED DOCUMENTS

- A. Examine Drawings, Contract Conditions all other Sections of the Specifications for requirements which affect work of this Section whether or not such work is specifically mentioned in this Section.
- B. Coordinate work with that of all other trades affecting, or affected by work of this Section. Cooperate with such trades to assure the steady progress of all Project work.

1.2 DESCRIPTION

Masonry mortar for brick and concrete masonry unit are specified in this section.

1.3 QUALITY ASSURANCE

Do not change source or brands of masonry mortar materials during the course of the work.

1.4 SUBMITTALS

- A. Manufacturer's Data and Mix Designs:
 - 1. Submit eight (8) copies of manufacturers' specifications and instructions for each manufactured product.
 - 2. Include test reports for mortar mixes required to comply with property specification. Test according to ASTM C 109/C 109M for compressive strength, ASTM C 1506 for water retention, and ASTM C 91/C 91M for air content.
 - 3. Include test reports, according to ASTM C 1019, for grout mixes required to comply with compressive strength requirement.
- B. Samples:
 - 1. Submit samples of each type of colored masonry mortar, showing the range of color which can be expected in the finished work. Label samples to indicate type and amount of colorant used. Engineer's review will be for color only. Compliance with all other requirements is exclusively the responsibility of the Contractor.

PART 2 - MATERIALS

2.1 MATERIALS

- A. Portland Cement: ASTM C 150, Type I, non-staining, without air entrainment and of natural color or white as required to produce the required color of mortar or grout.
- B. Hydrated Lime: ASTM C 207, Type S.
- C. Aggregates for Mortar: ASTM C 144, except for joints less than 1/4 inch use aggregate graded with 100% passing the No. 16 sieve.
- D. Aggregate for Grout: ASTM C 404.
- E. Water: Clean, potable, free of deleterious materials which would impair strength or bond.
- F. Colored Mortar Pigments: Natural and synthetic iron oxides and chromium oxides, compounded for use in mortar mixes. Use only pigments with record of satisfactory performance in masonry mortars. Do not exceed pigment-to-cement ratio, by weight, of 1-to-7. Subject to compliance with requirements, colored mortar pigments which may be incorporated in the work include, but are not limited to, the following:
 - 1. Solomon Grind-Chem Services, Inc.; "SGS Mortar Colors".
 - 2. Davis Colors, A Subsidiary of Rockwood Industries, Inc.; "True Tone Mortar Colors".
 - 3. Similar colors manufactured by Bonsol Construction Products or Riverton Lime and Stone Co. are acceptable.
- G. Do not use calcium chloride in mortar or grout.

2.2 MORTAR MIXES

- A. Do not lower the freezing point of mortar by use of admixtures or antifreeze agents.
- B. Do not use masonry cement.
- C. Do not use calcium chloride or other antifreeze compounds in mortar or grout.
- D. Mortar for Unit Masonry (Proportion by Volume Method): Non-staining, cement-lime mortar complying with ASTM C 270, "Table 1, Proportion Specification Requirements", but limiting acceptable types to those listed below for cement-lime mixes.
 - 1. Type M: 1/4 part lime per part of Portland Cement.
 - 2. Type S: Over 1/4 up to 1/2 part lime per part of Portland Cement.

- E. Use the following mortar mix for the applications indicated.
 - 1. Use Type M mortar for masonry below grade and in contact with earth.
 - 2. Use Type S mortar for other applications.
- F. Colored Pigmented Cement Mortar:
 - 1. Proportion pigments with other ingredients to match sample approved by the Engineer.

2.3 GROUT MIX

- A. Comply with ASTM C 476 for fine grout
- B. Portland cement, sand, gravel and water, proportioned as required to provide a 28-day minimum compressive strength of 3,000 psi.
- C. Aggregate for Grout: ASTM C 404.

PART 3 – EXECUTION

- 3.1 Refer to Section 04050, "Unit Masonry, General" for required installation procedures of mortar and grout specified in this section.

END OF SECTION

SECTION 04150

MASONRY ACCESSORIES

PART 1 - GENERAL

1.1 RELATED DOCUMENTS

- A. Drawings, Contract Conditions and other Technical Specifications Sections apply to work of this Section insofar as applicable.
- B. Coordinate work with that of all other trades affecting, or affected by work of this Section. Cooperate with such trades to assure the steady progress of all Project work.

1.2 DESCRIPTION

- A. Section 04050, "Unit Masonry, General" specifies the installation of masonry work including the accessories specified under this section.
- B. Section 03300, "Cast-in-Place Concrete" specifies deformed reinforcing bars within concrete masonry units.
- C. The location of the masonry work is shown on the Drawings. The types of masonry accessories required include the following:
 - 1. Continuous horizontal wire reinforcing.
 - 2. Vertical bar type reinforcing.
 - 3. Anchoring devices for masonry.
 - 4. Concealed flashings built into masonry work.
 - 5. Control joint strips.
 - 6. Masonry weep joints.
 - 7. Filler strips at tops of masonry partitions.
 - 8. Drip plates
 - 9. Precast concrete sills.

1.3 SUBMITTALS

- A. Manufacturer's Data:
 - 1. Submit eight (8) copies of manufacturer's specifications and installation instructions for each masonry accessory required and listed below. Include data substantiating that materials comply with specified requirements.
 - a. Horizontal wall reinforcing
 - b. Masonry and tie anchors
 - c. Rigid steel anchors

B. Test and Engineering Data:

1. Submit eight (8) copies of certifications of load tests or engineering data substantiating capability of the anchors to withstand the imposed compression/tension loads.

PART 2 - MATERIALS

2.1 REINFORCEMENT AND ANCHORS

A. All materials shall be hot-dip galvanized in accordance with ASTM A 153, Class B2.

B. Horizontal Wall Reinforcing: Extra heavy-duty (galvanized in accordance with ASTM A-153 at exterior walls and interior walls in humid and wet areas) continuous truss type in accordance with ASTM A1064 and ASTM A951. Provide preformed corner and intersection units. Vertical spacing of reinforcement courses shall be 8 inches on center unless closer spacing is shown on the Drawings. However, in all cases, place reinforcement in the first two course joints immediately over and under openings, extending not less than 48 inches on each side, and in bottom of three course beds, and the top course bed. Unit width shall be such that the side rods center on the walls of hollow masonry units. Reinforcing shall be Hohmann & Barnard, Inc. units listed below or approved equal products manufactured by Dur-O-Wall Products, Inc. or AA Wire Products Co.

1. Single Wythe: Hohmann & Barnard, Inc., "Truss Mesh" #120, 3/16 inch side rods, #9 cross rods, hot dip galvanized in accordance with ASTM A 153, Class B2.
2. Double Wythe and Cavity: Hohmann & Barnard, Inc., "#165-S.I.S." consisting of #165 Truss Box Mesh (3/16 inch side rods, #9 cross rods, 3/16 inch boxes); "Seismiclip"; 3/16 inch "Byna-tie"; 3/16 inch Continuous Wire; all hot dip galvanized in accordance with ASTM A 153, Class B2 except continuous wire to be mill galvanized in accordance with ASTM A 116/641, Class 3.
3. Continuous wire reinforcement is required for all 4 inches thick (nominal) and wider units.
4. Continuous horizontal reinforcement (e.g., truss type and single wire type) shall be secured to each masonry anchor with "Seismiclips".

C. Masonry Anchors:

1. Masonry to Steel Stud: Hohmann & Barnard #DW-10 with 3/16 "Byna-Tie" and "Seismiclip", or approved equal by AA Wire Products Co. or Dur-O-Wall, Inc.
2. Masonry to Concrete: Hohmann & Barnard #305 Dovetail Slot, #315-BT Flexible Dovetail and "Seismiclip", or approved equal by AA Wire Products Co. or Dur-O-Wall, Inc.

D. Rigid Steel Anchors: 1 1/2" x 1/4" x 2'-0" long with ends turned up 2 inches in opposite directions or with acceptable cross pins.

2.2 FLASHING FOR MASONRY

- A. Copper Fabric Laminated: Copper sheet weighing 5 ounces per square foot bonded with asphalt between 2 layers of glass fiber cloth. Flashing shall be manufactured by one of the following:
1. Copper Fabric; Afco Products, Inc.
 2. Copper Fabric Flashing; Sandell Mfg., Co. Inc.
 3. Copper Fabric Flashing; York Mfg., Inc.
 4. Adhesive for flashing shall be as provided by the flashing manufacturer.

2.3 MISCELLANEOUS MASONRY ACCESSORIES

- A. Reinforcing Bars: Deformed steel, ASTM A 615, Grade 60, of the sizes shown.
- B. Embedded Anchors for Sill Plates Supporting Roof Trusses: ASTM A 307
- C. Preformed Control Joint Gaskets: Material as indicated below, designed to fit standard sash block and maintain lateral stability in masonry wall; size and configuration as indicated or required.
1. Styrene-Butadiene Rubber Compound: ASTM D 2000, Designation M2AA-805
- D. Weep Joints: Provide the following:
1. PVC Honeycomb: Provide 3/8" wide by height of bed joint prefabricated honeycomb units.
- E. Compressible Filler: Premolded filler strips complying with ASTM D 1056, Grade 2A1; compressible up to 35 percent; of width and thickness indicated; formulated from the following material.
1. Neoprene.
- F. Drip Plate: Provide the following:
1. Manufacturer: Hohmann & Barnard, Inc. Drip Plate DP-FTSA
 2. Width: 3"
 3. Foam-Tite Seal Width: 2.5"
 4. Material: Type 304 Stainless Steel (26 gauge)

2.4 PRECAST CONCRETE

- A. Architectural precast concrete: Provide custom fabricated, integrally colored sills, complying with the following:
1. Compressive strength: 5,000 psi minimum at 28 days.

2. Entrained air: 5% - 6%.
3. Finish: Light sandblast finish approved by the Authority.
4. Formwork: Comply with applicable requirements of ACI 347, and with PCA forms of Architectural Concrete. Forms shall bear APA grade-trademark and shall have specially formulated aluminum edge sealer. Provide forms true, straight and square. Where joints occur in forms, the interior surface shall be flush. Forms shall be braced rigidly. Prior to each pour, coat forms with approved non-staining form release agent that will not interfere with adhesion of sealants, insulation adhesives or applied finishes.
5. Reinforcement: Provide reinforcement as shown on shop drawings and as specified herein. Provide additional reinforcement required for handling, transportation and erection stresses. Reinforcement shall be cold rolled steel complying with ASTM A 615, Grade 60, deformed and welded wire fabric conforming to ASTM A 1064. Reinforcing steel shall be hot-dip galvanized after fabrication.
6. Detailing and fabrication of reinforcement shall conform to ACI 315 and ACI 315R.

PART 3 - EXECUTION

3.1 INSTALLATION

- A. Refer to Section 04050, "Unit Masonry, General" for installation of masonry accessories specified under this section.

END OF SECTION

SECTION 04210

BRICK MASONRY

PART 1 - GENERAL

1.1 RELATED DOCUMENTS

- A. Drawings, Contract Conditions and other Technical Sections apply to work of this Section insofar as applicable.
- B. Coordinate work with that of all other trades affecting, or affected by work of this Section. Cooperate with such trades to assure the steady progress of all Project work.

1.2 DESCRIPTION

- A. Brickwork is indicated on the Drawings. Installation of the face brick and common brick are specified in Section 04050, "Unit Masonry, General".
- B. Masonry mortar and grout is specified in Section 04100, "Masonry Mortar and Grout".
- C. Masonry accessories, including reinforcing, are specified in Section 04150, "Masonry Accessories".

1.3 QUALITY ASSURANCE

- A. Obtain face brick from one manufacturer, of uniform texture and color (or uniform blend in the variation thereof).
- B. Standards:

Facing Brick: ASTM C 216-75, Grade SW.

Building (Common) Brick: ASTM C 62.

1.4 SUBMITTALS

- A. Manufacturer's Data: Submit brick manufacturer's specifications and other data for each type of product required, including certification that each product complies with the specified requirements. Include instructions for handling, storage, installation and protection of each type of brick.
- B. Samples:
 - 1. Submit 5 samples of exposed brick. Include the full range of exposed color and texture to be expected in the completed work. Engineer's review will be for color and texture only. Compliance with all other requirements is exclusively the responsibility of the Contractor.

2. All brick when submitted for approval shall be accompanied by the manufacturer's statement of the following:

Compressive strength of the brick which will indicate the degree of hardness.

Certification that the brick submitted is Type SW (Severe Weather) brick.

Special instructions for laying the brick, if any.

Any modifications to the mortar mix which might be required for proper bond strength.

PART 2 - MATERIALS

2.1 MATERIALS FOR BRICK MADE FROM CLAY OR SHALE

- A. At Contractor's option, provide solid brick, cored or uncored, for vertical brickwork. Do not use cored brick with net cross-sectional area less than 75% of gross area in the same plane or with core holes less than 3/4 inch from any edge.

2.2 BRICK TYPES

- A. Face Brick: Comply with the requirements of ASTM C 216, Grade SW, Type FBS standard modular size brick shall be one of the following:

Belden Brick: 503-505A

Glen Gery: Carlton

Endicott: Rose Smooth

- B. Building (Common) Brick: Conform to ASTM C 62, Grade SW.

PART 3 - EXECUTION

3.1 INSTALLATION

Refer to Section 04050 "Unit Masonry, General" for installation of brick.

END OF SECTION

SECTION 04220

CONCRETE MASONRY UNITS

PART 1 - GENERAL

1.1 RELATED DOCUMENTS

- A. Drawings, Contract Conditions and Technical Sections apply to work of this Section insofar as applicable.
- B. Coordinate work with that of all other trades affecting, or affected by work of this Section. Cooperate with such trades to assure the steady progress of all Project work.

1.2 DESCRIPTION

- A. Concrete masonry units (CMU) are indicated on the Drawings. The types of concrete masonry units required include the following:
 - 1. Hollow load bearing block, normal weight.
- B. Includes installation of field applied weatherproofing at exterior face of CMU within cavity.
- C. Section 04050, "Unit Masonry, General" specifies installation of CMU.
- D. Section 04100, "Masonry Mortar and Grout" specifies mortar for masonry construction.
- E. Section 04150, "Masonry Accessories" specifies accessories, including reinforcing.

1.3 QUALITY ASSURANCE

- A. Fire Performance Characteristics: Where indicated, provide materials and construction which are identical to those of assemblies whose fire endurance has been determined by testing in compliance with ASTM E 119 by a recognized testing and inspecting organization or by another means, as acceptable to authority having jurisdiction.
- B. Obtain units from one manufacturer, cured by one process, and of uniform texture and color for each type required, for each continuous area and visually related areas.
- C. Standards: Concrete masonry units shall be normal weight and manufactured to meet ASTM C 90 requirements.
 - 1. Unit Compressive Strength: Provide units with a minimum average net-area compressive strength of 1,800 psi.

1.4 SUBMITTALS

- A. Product Data: Submit manufacturer's data for 4" and 8" concrete masonry units required, including certified copies of laboratory test reports and other data as may be required to show compliance with specified requirements.
- B. Samples: Submit 5 samples of each type of concrete masonry unit required to be painted. Select units to show range of texture which can be expected in the finished work.

PART 2 – MATERIAL

2.1 CONCRETE MASONRY UNIT MATERIALS

A. General

Comply with referenced standards and other requirements indicated below applicable to each form of concrete masonry unit required.

Size: Manufacturer's standard units with nominal face dimensions of 16 inches long x 8 inches high (15-5/8" x 7-5/8" actual) of the various widths shown, unless otherwise indicated.

Exposed Faces: Provide manufacturer's standard color and texture, unless otherwise indicated. Wherever concrete units are indicated to be painted, provide fine-textured units.

Special Shapes: Provide for lintels, corners, jambs, sash, control joints, headers, bonding and other special conditions.

B. Concrete Block

Where concrete blocks are shown, comply with the following classifications, weights, grades, curing, and other requirements as indicated.

1. Grade: Grade N.
2. Type: Provide Type I, moisture-controlled.

Cure units by autoclave treatment at a minimum temperature of 350°F (176°C) and a minimum pressure of 125 psi.

Limit moisture absorption of 25% of saturation during delivery and until time of installation.

3. Hollow Load bearing Block: ASTM C 90, normal weight.

4. Solid Load bearing Block: ASTM C 145, normal weight using concrete aggregates complying with ASTM C 33, producing a dry net weight of not more than 125 pounds per cubic foot.
- C. Field Applied Water Resistive Barrier: Similar to Carlisle Barritech NP

PART 3 - EXECUTION

3.1 INSTALLATION

Refer to Section 04050, "Unit Masonry, General" for installation of the concrete masonry units specified in this section.

Install water resistive barrier at exterior face of CMU wall in accordance with the manufacturer's installation instructions.

END OF SECTION

SECTION 05100

STRUCTURAL STEEL FRAMING

PART 1 - GENERAL

1.1 RELATED DOCUMENTS

- A. Drawings, Contract Conditions and other Technical Sections apply to work of this Section insofar as applicable.
- B. Coordinate work with that of all other trades affecting, or affected by work of this Section. Cooperate with such trades to assure the steady progress of all Project work.
- C. Section Includes:
 - 1. Structural Steel.
 - 2. Shop-priming Structural Steel Unless Specified Below to be Galvanized.
 - 3. Galvanizing Moment Frame Columns and Beams and Welded Steel Lintel Plates and Angles Supporting Brick Façade.
 - 4. Non-Shrink Grout.
- D. Related Requirements:
 - 1. Steel Decking - Section 05310 (canopy roof metal deck)
 - 2. Metal Fabrications – Section 05500 (steel lintels not attached to structural-steel frame and miscellaneous steel fabrications and other steel items not defined as structural steel)
 - 3. Painting – Section 09900 for painting of structural steel as called out on the architectural Drawings.

1.2 DEFINITIONS

- A. Structural Steel: Elements of the structural frame indicated on Drawings and as described in AISC 303, "Code of Standard Practice for Steel Buildings and Bridges."

1.3 COORDINATION

- A. Coordinate selection of shop primers with topcoats to be applied over them. Comply with paint and coating manufacturers' written recommendations to ensure that shop primers and topcoats are compatible with one another.
- B. Coordinate installation of anchorage items to be embedded in or attached to other construction without delaying the Work. Provide setting diagrams, sheet metal templates, instructions, and directions for installation.

1.4 PREINSTALLATION MEETINGS

- A. Preinstallation Conference: Conduct conference at Project site.

1.5 SUBMITTALS

- A. The Engineer of Record (EOR) shall receive all submittals a minimum of two weeks prior to the start of fabrication. The Contractor shall have received and approved all submittals prior to review by the Engineer. All review of submittals by the Engineer, Architect, and Contractor shall be completed prior to fabrication and installation of any material or product.
- B. Product Data: For each type of product, submit producer's or manufacturer's specifications and installation instructions.
- C. Shop Drawings: Show fabrication of structural-steel components.
 - 1. Include details of cuts, connections, splices, camber, holes, and other pertinent data.
 - 2. Include embedment Drawings.
 - 3. Indicate welds by standard AWS symbols, distinguishing between shop and field welds, and show size, length, and type of each weld. Show backing bars that are to be removed and supplemental fillet welds where backing bars are to remain.
 - 4. Indicate type, size, and length of bolts, distinguishing between shop and field bolts. Identify pretensioned and slip-critical, high-strength bolted connections.
 - 5. Re-use of structural contract documents as erection or detail drawings will not be permitted.
 - 6. The Engineer/Architect reserves the right to make revisions during the shop drawing review. These revisions shall be incorporated into the shop drawings at no additional cost.
- D. Qualification Data: For Installer, Fabricator, and Testing Agency.
- E. Welding certificates.
- F. Mill test reports for structural steel, including chemical and physical properties.
- G. Product Test Reports: For the following:
 - 1. Bolts, nuts, and washers including mechanical properties and chemical analysis.
 - 2. Direct-tension indicators.
 - 3. Tension-control, high-strength, bolt-nut-washer assemblies.
 - 4. Shear stud connectors.
 - 5. Shop primers.
 - 6. Non-shrink grout.
- H. Survey of existing conditions.
- I. Shop and field quality control test reports for bolted and welded connections.

1.6 QUALITY ASSURANCE

- A. Fabricator Qualifications: A qualified fabricator that participates in the AISC Quality Certification Program and is designated an AISC-Certified Plant, Category BU.

- B. Installer Qualifications: A qualified installer with a minimum of 10 years of experience in installing structural steel.
- C. Welding Qualifications: Qualify procedures and personnel according to AWS D1.1/D1.1M, "Structural Welding Code - Steel."
- D. Galvanizer Qualifications: Engage the services of a qualified galvanizer who has demonstrated a minimum of five years of experience in the successful application of galvanized coatings specified in this Section in the facility where the work is to be performed and who will apply the coatings within the same facility.
- E. Comply with applicable provisions of the following specifications and documents:
 - 1. AISC 303.

1.7 DELIVERY, STORAGE, AND HANDLING

- A. Store materials to permit easy access for inspection and identification. Keep steel members off ground and spaced by using pallets, dunnage, or other supports and spacers. Protect steel members and packaged materials from corrosion and deterioration.
 - 1. Do not store materials on structure in a manner that might cause distortion, damage, or overload to members or supporting structures. Repair or replace damaged materials or structures as directed.
- B. Store fasteners in a protected place in sealed containers with manufacturer's labels intact.
 - 1. Fasteners may be repackaged provided Owner's testing and inspecting agency observes repackaging and seals containers.
 - 2. Clean and re-lubricate bolts and nuts that become dry or rusty before use.
 - 3. Comply with manufacturers' written recommendations for cleaning and lubricating ASTM F 1852 fasteners and for retesting fasteners after lubrication.

PART 2 - MATERIALS

2.1 STRUCTURAL-STEEL MATERIALS

- A. W-Shapes: ASTM A 992 Grade 50
- B. Angles, Plates, and Bar: ASTM A 36
- C. Channels: ASTM A 36
- D. Hollow Structural Steel – Square: ASTM A 500, Grade B (Fy = 46,000 ksi)
- E. Hollow Structural Steel – Round: ASTM A 500, Grade B (Fy = 42,000 ksi)

- F. Steel Pipe: ASTM A 53 Grade B.
- G. Welding Electrodes: Comply with AWS requirements.

2.2 BOLTS, CONNECTORS, AND ANCHORS

- A. High-Strength Bolts, Nuts, and Washers: ASTM A 325 Type 1, heavy-hex steel structural bolts; ASTM A 563, Grade C, heavy-hex carbon-steel nuts; and ASTM F 436, Type 1, hardened carbon-steel washers; all with plain finish.
 - 1. Direct-Tension Indicators: ASTM F 959, Type 325, compressible-washer type with plain finish.
- B. Tension-Control, High-Strength Bolt-Nut-Washer Assemblies: ASTM F 1852, Type 1, heavy-hex head assemblies consisting of steel structural bolts with splined ends, heavy-hex carbon-steel nuts, and hardened carbon-steel washers.
- C. Shear Connectors: ASTM A 108, Grades 1015 through 1020, headed-stud type, cold-finished carbon steel; AWS D1.1/D1.1M, Type B.
- D. All hardware shall be uncoated unless otherwise noted on the Drawings.

2.3 GROUT

- A. Nonmetallic, Shrinkage-Resistant Grout: ASTM C 1107/C 1107M, factory-packaged, nonmetallic aggregate grout, noncorrosive and nonstaining, mixed with water to consistency suitable for application and a 30-minute working time.

2.4 FABRICATION

- A. Structural Steel: Fabricate and assemble in shop to greatest extent possible. Fabricate according to AISC 303, "Code of Standard Practice for Steel Buildings and Bridges," and to AISC 360.
 - 1. Fabricate beams with rolling camber up.
 - 2. Identify high-strength structural steel according to ASTM A 6/A 6M and maintain markings until structural steel has been erected.
 - 3. Mark and match-mark materials for field assembly.
 - 4. Complete structural-steel assemblies, including welding of units, before hot-dipped galvanizing.
- B. Thermal Cutting: Perform thermal cutting by machine to greatest extent possible.
 - 1. Plane thermally cut edges to be welded to comply with requirements in AWS D1.1/D1.1M.
- C. Bolt Holes: Cut, drill, or punch standard bolt holes perpendicular to metal surfaces.

- D. Finishing: Accurately finish ends of columns and other members transmitting bearing loads.
- E. Shear Connectors: Prepare steel surfaces as recommended by manufacturer of shear connectors. Use automatic end welding of headed-stud shear connectors according to AWS D1.1 and manufacturer's written instructions.
- F. Cut, drill, or punch holes perpendicular to steel surfaces.
- G. Baseplate Holes: Cut, drill, mechanically thermal cut, or punch holes perpendicular to steel surfaces.
- H. Metal Primer Paint: Except as otherwise noted, apply the following Tnemec primer, or approved equal by PPG, Devoe or DuPont to all non-galvanized ferrous surfaces.
 - 1. Tnemec Series 10-99 Modified Alkyd Rust Inhibitive Primer, 3 dry mils, spray applied.

2.5 SHOP CONNECTIONS

- A. High-Strength Bolts: Shop install high-strength bolts according to RCSC's "Specification for Structural Joints Using ASTM A 325 or A 490 Bolts" for type of bolt and type of joint specified.
 - 1. Joint Type: Snug tightened.

2.6 GALVANIZING

- A. Hot-Dip Galvanized Finish: Where required on the Drawings and at locations listed below, apply zinc coating by the hot-dip process to structural steel according to ASTM A 123/A 123M.
 - 1. Fill vent and drain holes that are exposed in the finished Work unless they function as weep holes, by plugging with zinc solder and filing off smooth.
 - 2. Galvanize moment frame columns and beams along exterior walls which include welded lintel plates and angles to support brick façade.

2.7 SHOP QUALITY CONTROL

- A. Testing Agency: Engage a qualified testing agency to perform shop tests and inspections.
 - 1. Provide testing agency with access to places where structural-steel work is being fabricated or produced to perform tests and inspections.
- B. Bolted Connections: Inspect and test shop-bolted connections according to RCSC's "Specification for Structural Joints Using ASTM A 325 or A 490 Bolts."

- C. Welded Connections: Visually inspect shop-welded connections according to AWS D1.1/D1.1M and the following inspection procedures, at testing agency's option:
 - 1. Magnetic Particle Inspection: ASTM E 709; performed on root pass and on finished weld. Cracks or zones of incomplete fusion or penetration are not accepted.
 - 2. Ultrasonic Inspection: ASTM E 164.
 - 3. Radiographic Inspection: ASTM E 94.
- D. In addition to visual inspection, test and inspect shop-welded shear connectors according to requirements in AWS D1.1/D1.1M for stud welding and as follows:
 - 1. Perform bend tests if visual inspections reveal either a less-than-continuous 360-degree flash or welding repairs to any shear connector.
 - 2. Conduct tests according to requirements in AWS D1.1/D1.1M on additional shear connectors if weld fracture occurs on shear connectors already tested.
- E. Prepare test and inspection reports.

PART 3 - EXECUTION

3.1 EXAMINATION

- A. Verify, with certified steel erector present, elevations of concrete- and masonry-bearing surfaces and locations of anchor rods, bearing plates, and other embedments for compliance with requirements.
 - 1. Prepare a certified survey of existing conditions. Include bearing surfaces, anchor rods, bearing plates, and other embedments showing dimensions, locations, angles, and elevations.
- B. Proceed with installation only after unsatisfactory conditions have been corrected.

3.2 PREPARATION

- A. Provide temporary shores, guys, braces, and other supports during erection to keep structural steel secure, plumb, and in alignment against temporary construction loads and loads equal in intensity to design loads. Remove temporary supports when permanent structural steel, connections, and bracing are in place unless otherwise indicated.

3.3 ERECTION

- A. Set structural steel accurately in locations and to elevations indicated and according to AISC 303 and AISC 360.

- B. Baseplates, Bearing Plates, and Leveling Plates: Clean concrete- and masonry-bearing surfaces of bond-reducing materials, and roughen surfaces prior to setting plates. Clean bottom surface of plates.
 - 1. Set anchor rods by template.
 - 2. Set plates for structural members on wedges, shims, or setting nuts as required.
 - 3. Weld plate washers to top of baseplate.
 - 4. Snug-tighten anchor rods after supported members have been positioned and plumbed. Do not remove wedges or shims but, if protruding, cut off flush with edge of plate before packing with grout.
 - 5. Promptly pack grout solidly between bearing surfaces and plates so no voids remain. Neatly finish exposed surfaces; protect grout and allow to cure. Comply with manufacturer's written installation instructions for shrinkage-resistant grouts.
- C. Maintain erection tolerances of structural steel within AISC 303, "Code of Standard Practice for Steel Buildings and Bridges."
- D. Align and adjust various members that form part of complete frame or structure before permanently fastening. Before assembly, clean bearing surfaces and other surfaces that are in permanent contact with members. Perform necessary adjustments to compensate for discrepancies in elevations and alignment.
 - 1. Level and plumb individual members of structure.
 - 2. Make allowances for difference between temperature at time of erection and mean temperature when structure is completed and in service.
- E. Splice members only where indicated.
- F. Do not use thermal cutting during erection.
- G. Do not enlarge unfair holes in members by burning or using drift pins. Ream holes that must be enlarged to admit bolts.
- H. Shear Connectors: Prepare steel surfaces as recommended by manufacturer of shear connectors. Use automatic end welding of headed-stud shear connectors according to AWS D1.1 and manufacturer's written instructions.

3.4 FIELD CONNECTIONS

- A. High-Strength Bolts: Install high-strength bolts according to RCSC's "Specification for Structural Joints Using ASTM A 325 or A 490 Bolts" for type of bolt and type of joint specified.
 - 1. Joint Type: Snug tightened
- B. Weld Connections: Comply with AWS D1.1 for tolerances, appearances, welding procedure specifications, weld quality, and methods used in correcting welding work.

1. Remove backing bars or runoff tabs where indicated, back gouge, and grind steel smooth.
2. Assemble and weld built-up sections by methods that maintain true alignment of axes without exceeding tolerances in AISC 303, "Code of Standard Practice for Steel Buildings and Bridges," for mill material.

3.5 FIELD QUALITY CONTROL

- A. Testing Agency: Engage a qualified testing agency to perform tests and inspections, and prepare reports of their findings. All connections must pass these inspections prior to the installation of subsequent work which they support.
- B. Testing agency reports shall state which specific connections were examined or tested, whether the connections comply with the contract documents and what deviations, if any, were noted. Copies of these reports shall be submitted to the Engineer for review.
- C. The Contractor shall provide the testing agency and special inspector access to places where structural steel work is being fabricated or erected so that the required inspection and testing can be accomplished.
- D. Testing agency may inspect structural steel at the plant before shipment. The Engineer reserves the right at any time before final acceptance to reject material not complying with the specified requirements.
- E. Bolted Connections: Inspect and test bolted connections according to RCSC's "Specification for Structural Joints Using ASTM A 325 or A 490 Bolts."
- F. Welded Connections: Visually inspect field welds according to AWS D1.1/D1.1M.
 1. In addition to visual inspection, test and inspect field welds according to AWS D1.1/D1.1M and the following inspection procedures, at testing agency's option:
 - a. Magnetic Particle Inspection: ASTM E 709; performed on root pass and on finished weld. Cracks or zones of incomplete fusion or penetration are not accepted.
 - b. Ultrasonic Inspection: ASTM E 164.
 - c. Radiographic Inspection: ASTM E 94.

3.6 REPAIRS AND PROTECTION

- A. Galvanized Surfaces: Clean areas where galvanizing is damaged or missing and repair galvanizing to comply with ASTM A 780.
- B. Touchup Painting: Immediately after erection, clean exposed areas where primer is damaged or missing and paint with the same material as used for shop painting to comply with SSPC-PA 1 for touching up shop-painted surfaces.

1. Clean and prepare surfaces by SSPC-SP 2 hand-tool cleaning or SSPC-SP 3 power-tool cleaning.

3.7 ENGINEER'S REVIEW

- A. The Engineer of Record will conduct periodic reviews of the construction for compliance with the provisions of the Contract Documents during the construction period.
- B. The General Contractor shall employ a professional engineer, licensed to practice in the State of Maine, to analyze and design modifications and repairs for construction not in conformance with the provisions of the Contract Documents. These modifications and repair details shall be stamped by the professional engineer and submitted with calculations for approval by the Engineer of Record. Modifications shall not be made without express written approval.

END OF SECTION

SECTION 05200

PIPE AND TUBE RAILINGS

PART 1 - GENERAL

1.1 RELATED DOCUMENTS

- A. Examine Drawings, Contract Conditions all other Sections of the Specifications for requirements which affect work of this Section whether or not such work is specifically mentioned in this Section.
- B. Coordinate work with that of all other trades affecting, or affected by work of this Section. Cooperate with such trades to assure the steady progress of all Project work.

1.2 SUMMARY

- A. Section Includes:
 - 1. Steel pipe and tube railings.
- B. Related Requirements:
 - 1. Metal Pan Stairs - Section 05513 for steel tube railings associated with metal pan stairs.
 - 2. Painting – Section 09900 for field-painting of exterior railings.

1.3 COORDINATION

- A. Coordinate selection of shop primers with topcoats to be applied over them. Comply with paint and coating manufacturers' written recommendations to ensure that shop primers and topcoats are compatible with one another.
- B. Coordinate installation of anchorages for railings. Furnish setting drawings, templates, and directions for installing anchorages, including sleeves, concrete inserts, anchor bolts, and items with integral anchors, that are to be embedded in concrete or masonry. Deliver such items to Project site in time for installation.
- C. Schedule installation so wall attachments are made only to completed walls. Do not support railings temporarily by any means that do not satisfy structural performance requirements.

1.4 SUBMITTALS

- A. Product Data: For the following:

1. Railing brackets.
 2. Grout
- B. Shop Drawings: Include plans, elevations, sections, details, and attachments to other work.
- C. Qualification Data: For testing agency.
- D. Welding certificates.
- E. Product Test Reports: For pipe and tube railings, for tests performed by a qualified testing agency, according to ASTM E 894 and ASTM E 935.
- F. Evaluation Reports: For post-installed anchors, from ICC-ES.
- 1.5 QUALITY ASSURANCE
- A. Welding Qualifications: Qualify procedures and personnel according to the following:
1. AWS D1.1/D1.1M, "Structural Welding Code - Steel."
- 1.6 DELIVERY, STORAGE, AND HANDLING
- A. Protect mechanical finishes on exposed surfaces from damage by applying a strippable, temporary protective covering before shipping.
- 1.7 FIELD CONDITIONS
- A. Field Measurements: Verify actual locations of walls and other construction contiguous with metal fabrications by field measurements before fabrication.

PART 2 - MATERIALS

2.1 PERFORMANCE REQUIREMENTS

- A. Structural Performance: Railings, including attachment to building construction, shall withstand the effects of gravity loads and the following loads and stresses within limits and under conditions indicated:
1. Handrails and Top Rails of Guards:
 - a. Uniform load of 50 lbf/ ft. applied in any direction.
 - b. Concentrated load of 200 lbf applied in any direction.
 - c. Uniform and concentrated loads need not be assumed to act concurrently.
 2. Infill of Guards:

- a. Concentrated load of 50 lbf applied horizontally on an area of 1 sq. ft.
 - b. Infill load and other loads need not be assumed to act concurrently.
- B. Thermal Movements: Allow for thermal movements from ambient and surface temperature changes.

2.2 METALS, GENERAL

- A. Metal Surfaces, General: Provide materials with smooth surfaces, without seam marks, roller marks, rolled trade names, stains, discolorations, or blemishes.
- B. Brackets, Flanges, and Anchors: Cast or formed metal of same type of material and finish as supported rails unless otherwise indicated.

2.3 STEEL

- A. Pipe: ASTM A 53, Type F or Type S, Grade A, Standard Weight (Schedule 40), unless another grade and weight are required by structural loads.
- B. Plates and Bars: ASTM A 36.
- C. Post-Installed Anchors: Torque-controlled expansion anchors capable of sustaining, without failure, a load equal to 6 times the load imposed when installed in unit masonry and 4 times the load imposed when installed in concrete, as determined by testing according to ASTM E 488/E 488M, conducted by a qualified independent testing agency.

2.4 MISCELLANEOUS MATERIALS

- A. Welding Rods and Bare Electrodes: Select according to AWS specifications for metal alloy welded.
- B. Etching Cleaner for Galvanized Metal: Complying with MPI#25.
- C. Galvanizing Repair Paint: High-zinc-dust-content paint complying with SSPC-Paint 20 and compatible with paints specified to be used over it.
- D. Nonshrink, Nonmetallic Grout: Factory-packaged, nonstaining, noncorrosive, nongaseous grout complying with ASTM C 1107/C 1107M. Provide grout specifically recommended by manufacturer for interior and exterior applications.

2.5 FABRICATION

- A. General: Fabricate railings to comply with requirements indicated for design, dimensions, member sizes and spacing, details, finish, and anchorage, but not less than that required to support structural loads.

- B. Shop assemble railings to greatest extent possible to minimize field splicing and assembly. Disassemble units only as necessary for shipping and handling limitations. Clearly mark units for reassembly and coordinated installation. Use connections that maintain structural value of joined pieces.
- C. Cut, drill, and punch metals cleanly and accurately. Remove burrs and ease edges to a radius of approximately 1/32 inch unless otherwise indicated. Remove sharp or rough areas on exposed surfaces.
- D. Form work true to line and level with accurate angles and surfaces.
- E. Fabricate connections that are exposed to weather in a manner that excludes water. Provide weep holes where water may accumulate.
- F. Cut, reinforce, drill, and tap as indicated to receive finish hardware, screws, and similar items.
- G. Connections: Fabricate railings with welded connections unless otherwise indicated.
- H. Welded Connections: Cope components at connections to provide close fit, or use fittings designed for this purpose. Weld all around at connections, including at fittings.
 - 1. Use materials and methods that minimize distortion and develop strength and corrosion resistance of base metals.
 - 2. Obtain fusion without undercut or overlap.
 - 3. Remove flux immediately.
 - 4. At exposed connections, finish exposed surfaces smooth and blended so no roughness shows after finishing and welded surface matches contours of adjoining surfaces.
- I. For changes in direction made by bending, use jigs to produce uniform curvature for each repetitive configuration required. Maintain cross section of member throughout entire bend without buckling, twisting, cracking, or otherwise deforming exposed surfaces of components.
- J. Provide wall returns at ends of wall-mounted handrails unless otherwise indicated. Close ends of returns unless clearance between end of rail and wall is 1/4 inch or less.
- K. Brackets, Flanges, Fittings, and Anchors: Provide wall brackets, flanges, miscellaneous fittings, and anchors to interconnect railing members to other work unless otherwise indicated.
 - 1. At brackets and fittings fastened to plaster or gypsum board partitions, provide crush-resistant fillers or other means to transfer loads through wall finishes to structural supports and prevent bracket or fitting rotation and crushing of substrate.
- L. Provide inserts and other anchorage devices for connecting railings to concrete or masonry work. Fabricate anchorage devices capable of withstanding loads imposed by railings. Coordinate anchorage devices with supporting structure.

- M. For railing posts set in concrete, provide PVC sleeves not less than 6 inches long embedded in concrete with cap at bottom of sleeve.

2.6 STEEL AND IRON FINISHES

A. Galvanized Railings:

1. Hot-dip galvanize steel railings at exterior of Toll Administration Building, including hardware, after fabrication.
 - a. Comply with ASTM A 123/A 123M for hot-dip galvanized railings.
 - b. Comply with ASTM A 153/A 153M for hot-dip galvanized hardware.
 - c. Do not quench or apply post galvanizing treatments that might interfere with paint adhesion.
 - d. Fill vent and drain holes that are exposed in the finished Work, unless indicated to remain as weep holes, by plugging with zinc solder and filing off smooth.

- B. Preparing Galvanized Railings for Shop Priming: After galvanizing, thoroughly clean railings of grease, dirt, oil, flux, and other foreign matter, and treat with etching cleaner.

- C. For nongalvanized-steel railings, provide nongalvanized ferrous-metal fittings, brackets, fasteners, and sleeves; however, galvanize anchors to be embedded in exterior concrete or masonry.

- D. Field-Painted Finish: Comply with Section 09900 "Painting."

PART 3 - EXECUTION

3.1 INSTALLATION, GENERAL

- A. Fit exposed connections together to form tight, hairline joints.
- B. Perform cutting, drilling, and fitting required for installing railings. Set railings accurately in location, alignment, and elevation; measured from established lines and levels and free of rack.
 1. Do not weld, cut, or abrade surfaces of railing components that are coated or finished after fabrication and that are intended for field connection by mechanical or other means without further cutting or fitting.
 2. Set posts plumb within a tolerance of 1/16 inch in 3 feet.
 3. Align rails so variations from level for horizontal members and variations from parallel with rake of steps and ramps for sloping members do not exceed 1/4 inch in 12 feet.
- C. Control of Corrosion: Prevent galvanic action and other forms of corrosion by insulating metals and other materials from direct contact with incompatible materials.
- D. Adjust railings before anchoring to ensure matching alignment at abutting joints.

- E. Fastening to In-Place Construction: Use anchorage devices and fasteners where necessary for securing railings and for properly transferring loads to in-place construction.

3.2 RAILING CONNECTIONS

- A. Welded Connections: Use fully welded joints for permanently connecting railing components. Comply with requirements for welded connections in "Fabrication" section of this Specification.

3.3 ANCHORING POSTS

- A. Form holes with PVC sleeves not less than 6 inches long for installing posts in concrete. Clean holes of loose material, insert posts, and fill annular space between post and PVC sleeve with nonshrink, nonmetallic grout, mixed and placed to comply with anchoring material manufacturer's written instructions.

3.4 ADJUSTING, CLEANING AND PAINTING

- A. Galvanized Surfaces: Clean field welds, bolted connections, and abraded areas, and repair galvanizing to comply with ASTM A 780/A 780M.
- B. Field-Painting: Immediately after erection, clean field welds, bolted connections, and abraded areas of shop paint, and paint exposed areas.

3.5 PROTECTION

- A. Protect finishes of railings from damage during construction period with temporary protective coverings approved by railing manufacturer. Remove protective coverings at time of Substantial Completion.

END OF SECTION

SECTION 05210

STEEL JOIST FRAMING

PART 1 – GENERAL

1.1 RELATED DOCUMENTS

- A. Drawings, Contract Conditions and other Technical Sections apply to work of this Section insofar as applicable.
- B. Coordinate work with that of all other trades affecting, or affected by work of this Section. Cooperate with such trades to assure the steady progress of all Project work.

1.2 SUMMARY

- A. Section Includes:
 - 1. K-series steel joists.
 - 2. Joist accessories.
- B. Related Requirements:
 - 1. Cast-In-Place Concrete – Section 03300 for material and installation of concrete floor slab; and for installation of embedded bearing plates with shear studs.
 - 2. Structural Steel Framing – Section 05100 for steel support framing.
 - 3. Steel Decking – Section 05310 for Toll Administration Building first floor deck form.
 - 4. Metal Fabrications – Section 05500 for fabrication of embedded plates and shear studs.

1.3 DEFINITIONS

- A. SJI's "Specifications": Steel Joist Institute's "Standard Specifications, Load Tables and Weight Tables for Steel Joists and Joist Girders."

1.4 SUBMITTALS

- A. Product Data: For each type of joist, accessory, and product.
- B. Shop Drawings:
 - 1. Include layout, designation, number, type, location, and spacing of joists.
 - 2. Include joining and anchorage details; bracing, bridging, and joist accessories; splice and connection locations and details; and attachments to other construction.
- C. Qualification Data: For manufacturer.

- D. Welding certificates.
- E. Manufacturer certificates.
- F. Mill Certificates: For each type of bolt.
- G. Field quality-control reports.

1.5 QUALITY ASSURANCE

- A. Manufacturer Qualifications: A manufacturer certified by SJI to manufacture joists complying with applicable standard specifications and load tables in SJI's "Specifications."
- B. Welding Qualifications: Qualify field-welding procedures and personnel according to AWS D1.1/D1.1M, "Structural Welding Code - Steel."

1.6 DELIVERY, STORAGE, AND HANDLING

- A. Deliver, store, and handle joists as recommended in SJI's "Specifications."
- B. Protect joists from corrosion, deformation, and other damage during delivery, storage, and handling.

PART 2 - MATERIALS

2.1 PERFORMANCE REQUIREMENTS

- A. Structural Performance:
 - 1. Provide joists and connections capable of withstanding design (unfactored) loads indicated on the Drawings.
 - 2. Provide vertical live load deflection ratio of $L/360$ of the span.
 - 3. Provide total dead and live load deflection ratio of $L/240$.

2.2 K-SERIES STEEL JOISTS

- A. Manufacture steel joists of type indicated according to "Standard Specification for Open Web Steel Joists, K-Series" in SJI's "Specifications," with steel-angle top- and bottom-chord members, underslung ends, and parallel top chord.
 - 1. Joist Type: K-series steel joists.
- B. Provide holes in chord members for connecting and securing other construction to joists.
- C. Do not camber joists.

2.3 JOIST ACCESSORIES

- A. Bridging: Schematically indicated on the Drawings. Detail and fabricate according to SJI's "Specifications." Furnish additional erection bridging if required for stability.
- B. Furnish ceiling extensions, either extended bottom-chord elements or a separate extension unit of enough strength to support ceiling construction. Extend ends to within 1/2 inch of finished wall surface unless otherwise indicated.
- C. Welding Electrodes: Comply with AWS standards for field-welding.
- D. Furnish miscellaneous accessories including splice plates and bolts required by joist manufacturer to complete joist assembly.

2.4 PRIMER

- A. Primer for Steel Joists: SSPC-Paint 15, or manufacturer's standard shop primer complying with performance requirements in SSPC-Paint 15.

2.5 CLEANING AND SHOP PRIMING

- A. Clean and remove loose scale, heavy rust, and other foreign materials from fabricated joists and accessories by hand-tool cleaning, SSPC-SP 2 or power-tool cleaning, SSPC-SP 3.
- B. Apply one coat of shop primer to joists and joist accessories to be primed to provide a continuous, dry paint film not less than 1 mil thick.

PART 3 - EXECUTION

3.1 EXAMINATION

- A. Examine supporting substrates, embedded bearing plates, and abutting structural framing for compliance with requirements for installation tolerances and other conditions affecting performance of the Work.
- B. Proceed with installation only after unsatisfactory conditions have been corrected.

3.2 INSTALLATION

- A. Do not install joists until supporting construction is in place and secured.
- B. Install joists and accessories plumb, square, and true to line; securely fasten to supporting construction according to SJI's "Specifications," joist manufacturer's written instructions, and requirements in this Section.
 - 1. Space, adjust, and align joists accurately in location before permanently fastening.

2. Install temporary bracing and erection bridging, connections, and anchors to ensure that joists are stabilized during construction.
- C. Field weld joists to supporting steel bearing plates and steel beam supports. Coordinate welding sequence and procedure with placement of joists. Comply with AWS requirements and procedures for welding, appearance and quality of welds, and methods used in correcting welding work.
- D. Install and connect bridging concurrently with joist erection, before construction loads are applied. Anchor ends of bridging lines at top and bottom chords if terminating at walls or beams.

3.3 FIELD QUALITY CONTROL

- A. Testing Agency: Engage a qualified testing agency to perform tests and inspections.
- B. Visually inspect field welds according to AWS D1.1/D1.1M.
- C. In addition to visual inspection, test 10% of field welds according to AWS D1.1/D1.1M and the following procedures, at testing agency's option:
 1. Magnetic Particle Inspection: ASTM E 709.
 2. Ultrasonic Testing: ASTM E 164.
 3. Radiographic Testing: ASTM E 94.
- D. Prepare test and inspection reports.

3.4 PROTECTION

- A. Touchup Painting: After installation, promptly clean, prepare, and prime or reprime field connections, rust spots, and abraded surfaces of prime-painted joists, bearing plates, abutting structural steel, and accessories.
 1. Clean and prepare surfaces by hand-tool cleaning according to SSPC-SP 2 or power-tool cleaning according to SSPC-SP 3.
 2. Apply a compatible primer of same type as primer used on adjacent surfaces.

END OF SECTION

SECTION 05310

STEEL DECKING

PART 1 – GENERAL

1.1 RELATED DOCUMENTS

- A. Drawings, Contract Conditions and other Technical Sections apply to work of this Section insofar as applicable.
- B. Coordinate work with that of all other trades affecting, or affected by work of this Section. Cooperate with such trades to assure the steady progress of all Project work.

1.2 SUMMARY

- A. Section Includes:
 - 1. Roof deck at plaza canopies and stair enclosures.
 - 2. Form deck for concrete first floor slab at Toll Administration Building.
- B. Related Requirements:
 - 1. Structural Steel Framing – Section 05100 for metal deck support framing.
 - 2. Steel Joist Framing – Section 05210 for form deck support framing.

1.3 SUBMITTALS

- A. Product Data: For each type of deck, accessory, and product indicated.
- B. Shop Drawings:
 - 1. Include layout and types of deck panels, anchorage details, reinforcing channels, pans, cut deck openings, special jointing, accessories, and attachments to other construction.
- C. Welding certificates.
- D. Product Certificates: For each type of steel deck.
- E. Product Test Reports: For tests performed by a qualified testing agency, indicating that each of the following complies with requirements:
 - 1. Power-actuated mechanical fasteners.
 - 2. Acoustical roof deck.
- F. Evaluation Reports: For steel deck, from ICC-ES.

1.4 DELIVERY, STORAGE, AND HANDLING

- A. Protect steel deck from corrosion, deformation, and other damage during delivery, storage, and handling.
- B. Stack steel deck on platforms or pallets and slope to provide drainage. Protect with a waterproof covering and ventilate to avoid condensation.

PART 2 - MATERIALS

2.1 PERFORMANCE REQUIREMENTS

- A. AISI Specifications: Comply with calculated structural characteristics of steel deck according to AISI's "North American Specification for the Design of Cold-Formed Steel Structural Members."

2.2 CANOPY AND STAIR ENCLOSURE ROOF DECK

- A. Roof Deck: Fabricate panels, without top-flange stiffening grooves, to comply with "SDI Specifications and Commentary for Steel Roof Deck," in SDI Publication No. 31, and with the following:
 - 1. Galvanized and Shop-Primed Steel Sheet: ASTM A 653, Structural Steel (SS), Grade 33, G60 zinc coating; cleaned, pretreated, and primed with manufacturer's standard baked-on, rust-inhibitive primer.
 - a. Color: Manufacturer's standard
 - 2. Deck Profile: Type WR, wide rib
 - 3. Profile Depth: 1-1/2 inches
 - 4. Design Uncoated-Steel Thickness: Gauge as indicated on the Drawings.
 - 5. Span Condition: Double span or more.
 - 6. Side Laps: Overlapped

2.3 NONCOMPOSITE FORM DECK FOR CONCRETE FLOOR SLAB

- A. Noncomposite Form Deck: Fabricate ribbed-steel sheet noncomposite form-deck panels to comply with "SDI Specifications and Commentary for Noncomposite Steel Form Deck," in SDI Publication No. 31, with the minimum section properties indicated, and with the following:
 - 1. Prime-Painted Steel Sheet: ASTM A 1008, Structural Steel (SS), Grade 33 minimum, with top and underside surface shop primed with manufacturer's standard baked-on, rust-inhibitive primer.
 - a. Color: Manufacturer's standard.

2. Profile Depth: 9/16 inch.
3. Design Uncoated-Steel Thickness: 0.0179 inch (min.).
4. Span Condition: Double span or more.

2.4 ACCESSORIES

- A. General: Provide manufacturer's standard accessory materials for deck that comply with requirements indicated.
- B. Mechanical Fasteners: Corrosion-resistant, low-velocity, power-actuated or pneumatically driven carbon-steel fasteners; or self-drilling, self-threading screws.
- C. Side-Lap Fasteners: Corrosion-resistant, hexagonal washer head; self-drilling, carbon-steel screws, No. 10 minimum diameter.
- D. Flexible Closure Strips: Vulcanized, closed-cell, synthetic rubber.
- E. Miscellaneous Sheet Metal Deck Accessories: Steel sheet, minimum yield strength of 33,000 psi, not less than 0.0359-inch design uncoated thickness, of same material and finish as deck; of profile indicated or required for application.
- F. Galvanizing Repair Paint: ASTM A 780.
- G. Repair Paint: Manufacturer's standard rust-inhibitive primer of same color as primer.

PART 3 - EXECUTION

3.1 EXAMINATION

- A. Examine supporting frame and field conditions for compliance with requirements for installation tolerances and other conditions affecting performance of the Work.
- B. Proceed with installation only after unsatisfactory conditions have been corrected.

3.2 INSTALLATION, GENERAL

- A. Install deck panels and accessories according to applicable specifications and commentary in SDI Publication No. 31, manufacturer's written instructions, and requirements in this Section.
- B. Install temporary shoring before placing deck panels if required to meet deflection limitations.
- C. Locate deck bundles to prevent overloading of supporting members.

- D. Place deck panels on supporting frame and adjust to final position with ends accurately aligned and bearing on supporting frame before being permanently fastened. Do not stretch or contract side-lap interlocks.
- E. Place deck panels flat and square and fasten to supporting frame without warp or deflection.
- F. Cut and neatly fit deck panels and accessories around openings and other work projecting through or adjacent to deck.
- G. Provide additional reinforcement and closure pieces at openings as required for strength, continuity of deck, and support of other work.
- H. Use mechanical fasteners to fasten deck. Locate mechanical fasteners and install according to deck manufacturer's written instructions.

3.3 ROOF-DECK INSTALLATION

- A. Fasten roof-deck panels to steel supporting members by mechanical fastening.
- B. Side-Lap and Perimeter Edge Fastening: Fasten side laps and perimeter edges of panels between supports, at intervals not exceeding the lesser of one-half of the span or 18 inches, and as follows:
 - 1. Mechanically fasten with self-drilling, No. 10 (4.8-mm-) diameter or larger, carbon-steel screws.
- C. End Bearing: Install deck ends over supporting frame with a minimum end bearing of 1-1/2 inches with end joints as follows:
 - 1. End Joints: Lapped 2 inches minimum
- D. Miscellaneous Roof-Deck Accessories: Install ridge and valley plates, finish strips, end closures, and reinforcing channels according to deck manufacturer's written instructions. Mechanically fasten to substrate to provide a complete deck installation.
- E. Flexible Closure Strips: Install flexible closure strips where indicated. Install with adhesive according to manufacturer's written instructions to ensure complete closure.

3.4 PROTECTION

- A. Galvanizing Repairs: Prepare and repair damaged galvanized coatings on both surfaces of deck with galvanized repair paint according to ASTM A 780 and manufacturer's written instructions.

- B. Repair Painting: Wire brush and clean rust spots, welds, and abraded areas on both surfaces of prime-painted deck immediately after installation, and apply repair paint.

END OF SECTION

SECTION 05500METAL FABRICATIONS

PART 1 – GENERAL

1.1 RELATED DOCUMENTS

- A. Examine Drawings, Contract Conditions all other Sections of the Specifications for requirements which affect work of this Section whether or not such work is specifically mentioned in this Section.
- B. Coordinate work with that of all other trades affecting, or affected by work of this Section. Cooperate with such trades to assure the steady progress of all Project work.

1.2 SUMMARY

- A. Section Includes:
 - 1. Steel framing and supports for mechanical and electrical equipment.
 - 2. Steel angles for grating and joist supports.
 - 3. Steel framing and supports for applications where framing and supports are not specified in other Sections.
 - 4. Cast-in and post-installed anchors.
 - 5. Loose bearing and leveling plates for applications where they are not specified in other Sections.
 - 6. Shop priming of all metal fabrications unless otherwise specified to be galvanized.
- B. Products furnished, but not installed, under this Section include the following:
 - 1. Loose steel lintels not attached to structural steel framing.
 - 2. Loose bearing and leveling plates.
 - 3. Pipe sleeves, sleeve anchors and expansion anchors indicated to be cast into concrete or built into unit masonry.
 - 4. Steel plates with welded studs, and angles for casting into concrete.
- C. Related Requirements:
 - 1. Cast-in-Place Concrete – Section 03300
 - 2. Structural Steel Framing – Section 05100
 - 3. Pipe and Tube Railings – Section 05200
 - 4. Steel Joist Framing – Section 05210
 - 5. Metal Pan Stairs – Section 05513
 - 6. Bar Grating – Section 05531
 - 7. Painting – Section 09900

1.3 COORDINATION

- A. Coordinate selection of shop primers with topcoats to be applied over them. Comply with paint and coating manufacturers' written recommendations to ensure that shop primers and topcoats are compatible with one another.
- B. Coordinate installation of metal fabrications that are anchored to or that receive other work. Furnish setting drawings, templates, and directions for installing anchorages, including sleeves, concrete inserts, anchor bolts, and items with integral anchors, that are to be embedded in concrete or masonry. Deliver such items to Project site in time for installation,
- C. Field Measurements: Where possible, take field measurements prior to preparation of shop drawings and fabrication. Do not delay job progress; allow for field trimming and fitting where taking field measurements before fabrication might delay work.

1.4 SUBMITTALS

- A. Product Data: Submit eight (8) copies of product data for the following items:
 - 1. Paint products.
 - 2. Post-installed anchors.
- B. Shop Drawings: Show fabrication and installation details. Include plans, elevations, sections, and details of metal fabrications and their connections. Show anchorage and accessory items.
 - 1. Provide Shop Drawings indicating locations and details for the following:
 - a. Steel framing and supports for mechanical and electrical equipment.
 - b. Steel framing and supports for applications where framing and supports are not specified in other Sections.
 - c. Loose steel lintels.
 - d. Loose bearing and leveling plates with shear studs.
 - e. Cast-in and post-installed anchors.
 - 2. Any discrepancies in the Contract Drawings shall be brought to the attention of the Engineer for adjustment. The Contractor shall verify field dimensions with those dimensions given on the Contractor's Drawings, and obtain by measurement at the site all necessary dimensions and levels dependent on construction in-place.
 - 3. Prior to submission of the shop drawings to the Engineer, they shall be pre-checked by the Contractor for conformity of detail with the Contract Documents and site conditions, and shall be coordinated with other work on the Project as necessary. The signature of a representative of the Contractor indicating that the shop drawings have been pre-checked will be required. The Contractor shall be wholly responsible for the conformity of dimensions and details of the shop drawings with the Contract Documents and site conditions.

4. After receipt of the shop drawings by the Engineer, they will be reviewed and necessary revisions will be marked on the sepias which will be returned to the Contractor. Revisions shall then be made and the shop drawings resubmitted. This procedure will be continued until the shop drawings are released for construction. The Contractor shall then deliver to the Engineer one transparency and three prints for his record and the use of his personnel.
5. At least one copy of each released shop drawing shall be kept available in the Contractor's field office; shop drawings not bearing evidence of release for construction by the Engineer shall not be kept on the job.

C. Welding certificates.

D. Research/Evaluation Reports: For post-installed anchors, from ICC-ES.

1.5 QUALITY ASSURANCE

- A. The work specified under this Section shall be performed by firms that have been engaged in the satisfactory manufacture and fabrication of work of the same type and magnitude as specified herein for a period of at least five years.
- B. Welding Qualifications: Qualify procedures and personnel according to AWS D1.1, "Structural Welding Code - Steel."
- C. Welding Qualifications: Qualify procedures and personnel according to the following:
 1. AWS D1.1/D1.1M, "Structural Welding Code - Steel."

1.6 FIELD CONDITIONS

- A. Field Measurements: Verify actual locations of walls and other construction contiguous with metal fabrications by field measurements before fabrication.

PART 2 - MATERIALS

2.1 METALS

- A. Metal Surfaces, General: Provide materials with smooth, flat surfaces unless otherwise indicated. For metal fabrications exposed to view in the completed Work, provide materials without seam marks, roller marks, rolled trade names, or blemishes.
- B. Steel Plates, Angles and Bars: ASTM A 36.
- C. Aluminum: All structural extrusions shall be 6063-T6; all other extrusions shall be 6063-T5. Steel Tubing: ASTM A 500, cold-formed steel tubing.
- D. Steel Pipe: ASTM A 53, Standard Weight (Schedule 40) unless otherwise indicated.

- E. Slotted Channel Framing: Cold-formed metal box channels (struts) complying with MFMA-4.
 - 1. Size of Channels: 1-5/8 by 1-5/8 inches
 - 2. Material: ASTM A 653, Grade 33, 12 gauge
- F. Shear Studs: ASTM A 108
- G. Expansion Bolts: Stainless steel "Kwik Bolts" as manufactured by Hilti Fastening Systems or approved equal.

2.2 FASTENERS

- A. General: Unless otherwise indicated, provide Type 316 stainless-steel fasteners for exterior use and zinc-plated fasteners with coating complying with ASTM B 633 or ASTM F 1941, Class Fe/Zn 5, at exterior walls. Select fasteners for type, grade, and class required.
- B. Anchors, General: Anchors capable of sustaining, without failure, a load equal to six times the load imposed when installed in unit masonry and four times the load imposed when installed in concrete, as determined by testing according to ASTM E 488, conducted by a qualified independent testing agency.
 - 1. Cast-In Anchor Rods: ASTM F 1554, Grade 55 unless noted otherwise on the Drawings.
 - a. Configuration: Straight.
 - b. Nuts: ASTM A 563 heavy-hex carbon steel.
 - c. Plate Washers: ASTM A 36 carbon steel.
 - d. Washers: ASTM F 436, Type 1, hardened carbon steel.
 - e. Finish: Hot-dipped galvanized at canopy column supports.
 - 2. Post-Installed Anchors: Torque-controlled expansion anchors or chemical anchors, as specified on the Drawings.

2.3 FABRICATION, GENERAL

- A. Shop Assembly: Preassemble items in the shop to greatest extent possible. Disassemble units only as necessary for shipping and handling limitations. Use connections that maintain structural value of joined pieces. Clearly mark units for reassembly and coordinated installation.
- B. Cut, drill, and punch metals cleanly and accurately. Remove burrs and ease edges to a radius of approximately 1/32 inch unless otherwise indicated. Remove sharp or rough areas on exposed surfaces.
- C. Form bent-metal corners to smallest radius possible without causing grain separation or otherwise impairing work.
- D. Form exposed work with accurate angles and surfaces and straight edges.

- E. Weld corners and seams continuously to comply with the following:
 - 1. Use materials and methods that minimize distortion and develop strength and corrosion resistance of base metals.
 - 2. Obtain fusion without undercut or overlap.
 - 3. Remove welding flux immediately.
 - 4. At exposed connections, finish exposed welds and surfaces smooth and blended so no roughness shows after finishing.
- F. Form exposed connections with hairline joints, flush and smooth, using concealed fasteners or welds where possible. Where exposed fasteners are required, use Phillips flat-head (countersunk) fasteners unless otherwise indicated. Locate joints where least conspicuous.
- G. Fabricate seams and other connections that are exposed to weather in a manner to exclude water. Provide weep holes where water may accumulate.
- H. Cut, reinforce, drill, and tap metal fabrications as indicated to receive finish hardware, screws, and similar items.
- I. Provide for anchorage of type indicated; coordinate with supporting structure. Space anchoring devices to secure metal fabrications rigidly in place and to support indicated loads.
- J. Metal Primer Paint: Except as otherwise noted, apply the following Tnemec primer, or approved equal by PPG, Devoe or DuPont to all non-galvanized ferrous surfaces.
 - 1. Tnemec Series 10-99 Modified Alkyd Rust Inhibitive Primer, 3 dry mils, spray applied.
- K. Shop Primer for Galvanized Steel: Primer formulated for exterior use over zinc-coated metal and compatible with finish paint systems indicated.
- L. Provide a zinc coating for items specified on the Drawings to be galvanized. Hot-dipped galvanizing shall conform to:
 - 1. ASTM A 123 for galvanized iron and steel products
 - 2. ASTM A 153 for galvanized iron and steel hardware.
- M. Galvanized Surfaces: Clean areas where galvanizing is damaged or missing and repair galvanizing to comply with ASTM A 780.

2.4 MISCELLANEOUS FRAMING AND SUPPORTS

- A. General: Provide steel framing and supports not specified in other Sections as needed to complete the Work.
- B. Fabricate units from steel shapes, plates, and bars of welded construction unless otherwise indicated. Fabricate to sizes, shapes, and profiles indicated and as necessary to receive adjacent construction.

1. Fabricate units from slotted channel framing where indicated.

C. Galvanize miscellaneous framing and supports where indicated on the Drawings

2.5 LOOSE BEARING AND LEVELING PLATES

A. Provide loose bearing and leveling plates for steel items bearing on masonry or concrete construction. Drill plates to receive anchor bolts and for grouting.

B. Galvanize plates.

C. Prime plates with zinc-rich primer.

2.6 LOOSE STEEL LINTELS

A. Fabricate loose steel lintels from steel angles and shapes of size indicated for openings and recesses in masonry walls and partitions at locations indicated on the Drawings. Fabricate in single lengths for each opening unless otherwise indicated. Weld adjoining members together to form a single unit where indicated.

B. Galvanize and prime loose steel lintels located in exterior walls.

C. Prime loose steel lintels located in exterior walls with zinc-rich primer.

2.7 STEEL WELD PLATES AND ANGLES

A. Provide steel weld plates and angles not specified in other Sections, for items supported from concrete construction as needed to complete the Work.

2.8 FINISHES, GENERAL

A. Finish metal fabrications after assembly.

B. Finish exposed surfaces to remove tool and die marks and stretch lines, and to blend into surrounding surface.

2.9 STEEL AND IRON FINISHES

A. Galvanizing: Hot-dip galvanize items as indicated to comply with ASTM A 153/A 153M for steel and iron hardware and with ASTM A 123/A 123M for other steel and iron products.

B. Preparation for Shop Priming Galvanized Items: After galvanizing, thoroughly clean railings of grease, dirt, oil, flux, and other foreign matter, and treat with metallic phosphate process.

- C. Shop prime iron and steel items not indicated to be galvanized unless they are to be embedded in concrete, sprayed-on fireproofing, or masonry, or unless otherwise indicated.
- D. Preparation for Shop Priming: Prepare surfaces to comply with SSPC-SP 6/NACE No. 3, "Commercial Blast Cleaning."
- E. Shop Priming: Apply shop primer to comply with SSPC-PA 1, "Paint Application Specification No. 1: Shop, Field, and Maintenance Painting of Steel," for shop painting.

PART 3 - EXECUTION

3.1 INSTALLATION, GENERAL

- A. Cutting, Fitting, and Placement: Perform cutting, drilling, and fitting required for installing metal fabrications. Set metal fabrications accurately in location, alignment, and elevation; with edges and surfaces level, plumb, true, and free of rack; and measured from established lines and levels.
- B. Fit exposed connections accurately together to form hairline joints. Weld connections that are not to be left as exposed joints but cannot be shop welded because of shipping size limitations. Do not weld, cut, or abrade surfaces of exterior units that have been hot-dip galvanized after fabrication and are for bolted or screwed field connections.
- C. Field Welding: Comply with the following requirements:
 - 1. Use materials and methods that minimize distortion and develop strength and corrosion resistance of base metals.
 - 2. Obtain fusion without undercut or overlap.
 - 3. Remove welding flux immediately.
 - 4. At exposed connections, finish exposed welds and surfaces smooth and blended so no roughness shows after finishing and contour of welded surface matches that of adjacent surface.
- D. Fastening to In-Place Construction: Provide anchorage devices and fasteners where metal fabrications are required to be fastened to in-place construction. Provide threaded fasteners for use with concrete and masonry inserts, toggle bolts, through bolts, lag screws, wood screws, and other connectors.
- E. Provide temporary bracing or anchors in formwork for items that are to be built into concrete, masonry, or similar construction.

3.2 INSTALLING MISCELLANEOUS FRAMING AND SUPPORTS

- A. General: Install framing and supports to comply with requirements of items being supported, including manufacturers' written instructions and requirements indicated on Shop Drawings.

3.3 INSTALLING BEARING AND LEVELING PLATES

- A. Clean concrete and masonry bearing surfaces of bond-reducing materials, and roughen to improve bond to surfaces. Clean bottom surface of plates.
- B. Set bearing and leveling plates on wedges, shims, or leveling nuts. After bearing members have been positioned and plumbed, tighten anchor bolts. Do not remove wedges or shims but, if protruding, cut off flush with edge of bearing plate before packing with nonshrink grout. Pack grout solidly between bearing surfaces and plates to ensure that no voids remain.

3.4 ADJUSTING AND CLEANING

- A. Restore finishes damaged during installation so that no evidence remains of corrective work.
- B. Touch-Up Painting: Immediately after erection, power tool clean in accordance with SSPC SP-3, field welds, bolted connections, and abraded areas of shop paint, and paint exposed areas with same material as used for shop painting. Apply by brush or spray to provide a minimum thickness of 2.0 dry mils of modified alkyd primer.
- C. For Galvanized Surfaces: Thoroughly clean field welds, bolted connections and abraded areas and apply 2 coats of approved galvanizing repair compound. Galvanizing repair compound shall comply with ASTM A 780.
- D. Restore aluminum finishes as directed by the fabricator and approved by the Engineer.

END OF SECTION

SECTION 05513

METAL PAN STAIRS

PART 1 – GENERAL

1.1 RELATED DOCUMENTS

- A. Examine Drawings, Contract Conditions all other Sections of the Specifications for requirements which affect work of this Section whether or not such work is specifically mentioned in this Section.
- B. Coordinate work with that of all other trades affecting, or affected by work of this Section. Cooperate with such trades to assure the steady progress of all Project work.

1.2 SUMMARY

A. Section Includes:

- 1. Preassembled steel stairs with concrete-filled treads.
- 2. Preassembled steel supports and connections for steel stairs.
- 3. Steel tube railings attached to metal stairs.
- 4. Steel tube handrails attached to walls adjacent to metal stairs.

B. Related Requirements:

- 1. Cast-in-Place Concrete – Section 03300 for concrete fill for stair treads and platforms.
- 2. Pipe and Tube Railings – Section 05200 for pipe and tube railings.
- 3. Painting – Section 09900 for painting of metal stairs at Toll Administration Building.

1.3 COORDINATION

- A. Coordinate selection of shop primers with topcoats to be applied over them. Comply with paint and coating manufacturers' written recommendations to ensure that shop primers and topcoats are compatible with one another.
- B. Coordinate installation of anchorages for metal stairs. Furnish setting drawings, templates, and directions for installing anchorages, including sleeves, concrete inserts, anchor bolts, and items with integral anchors, that are to be embedded in concrete or masonry. Deliver such items to Project site in time for installation.

1.4 SUBMITTALS

- A. Product Data: For metal pan stairs and the following:

1. Prefilled metal-pan-stair treads.
 2. Nonslip aggregates and nonslip-aggregate finishes.
 3. Paint products.
- B. Shop Drawings: Include plans, elevations, sections, details, and attachments to other work.
- C. Samples for Verification: For each type and finish of nosing and tread.
- D. Delegated-Design Submittal: Design calculations for stair and support framing including analysis data signed and sealed by the qualified professional engineer licensed in the State of Maine.
- E. Welding certificates.
- 1.5 QUALITY ASSURANCE
- A. Installer Qualifications: Fabricator of products.
- B. Welding Qualifications: Qualify procedures and personnel according to the following:
1. AWS D1.1/D1.1M, "Structural Welding Code - Steel."
 2. AWS D1.3/D1.3M, "Structural Welding Code - Sheet Steel."

PART 2 - PRODUCTS

2.1 PERFORMANCE REQUIREMENTS

- A. Delegated Design: Engage a qualified professional engineer licensed in the State of Maine to design the metal stair framing and supports.
- B. Structural Performance of Metal Stairs and Supports: Metal stairs and steel supports shall withstand the effects of gravity loads and the following loads and stresses within limits and under conditions indicated:
1. Dead Load: Include all steel components and concrete infill.
 2. Uniform Live Load: 100 lbf/sq. ft.
 3. Concentrated Live Load: 300 lbf applied on an area of 4 sq. in.
 4. Uniform and concentrated live loads need not be assumed to act concurrently.
 5. Stair Framing: Capable of withstanding stresses resulting from railing loads in addition to loads specified above.
 6. Limit live load deflection of treads, platforms, and framing members to **L/360**.
- C. Structural Performance of Railings: Railings shall withstand the effects of gravity loads and the following loads and stresses within limits and under conditions indicated:
1. Handrails and Top Rails of Guards:

- a. Uniform load of 50 lbf/ft. applied in any direction.
- b. Concentrated load of 200 lbf applied in any direction.
- c. Uniform and concentrated loads need not be assumed to act concurrently.

2. Infill of Guards:

- a. Concentrated load of 50 lbf applied horizontally on an area of 1 sq. ft.
- b. Infill load and other loads need not be assumed to act concurrently.

D. Seismic Performance of Stairs: Metal stairs shall withstand the effects of earthquake motions determined according to ASCE/SEI 7. Refer to the Drawings for earthquake design data.

2.2 METALS

- A. Metal Surfaces, General: Provide materials with smooth, flat surfaces unless otherwise indicated. For components exposed to view in the completed Work, provide materials without seam marks, roller marks, rolled trade names, or blemishes.
- B. W-Shapes: ASTM A 992 Grade 50
- C. Angles, Plates, and Bar: ASTM A 36
- D. Channels: ASTM A 36
- E. Hollow Structural Steel – Square: ASTM A 500, Grade B ($F_y = 46,000$ ksi)
- F. Cold-Rolled Steel Sheet at Toll Administration Building:
ASTM A 1008/A 1008M, either commercial steel, Type B, or structural steel, Grade 25, unless another grade is required by design loads; exposed.
- G. Galvanized-Steel Sheet at Tunnel Stairs: ASTM A 653/A 653M, G90 coating, either commercial steel, Type B, or structural steel, Grade 33, unless another grade is required by design loads.
- H. Provide anchors and embedded plates metal stair units, either integral or applied to units, as standard with manufacturer.

2.3 FASTENERS

- A. General: Provide zinc-plated fasteners with coating complying with ASTM B 633 or ASTM F 1941, Class Fe/Zn 12 for tunnel stairs. Select fasteners for type, grade, and class required.
- B. Bolts and Nuts: Regular hexagon-head bolts, ASTM A 307, Grade A; with hex nuts, ASTM A 563; and, where indicated, flat washers.
- C. Anchor Rods: ASTM F 1554, Grade 55, of dimensions indicated; with nuts, ASTM A 563; and, where indicated, flat washers.

- D. Post-Installed Anchors: Torque-controlled expansion anchors or chemical anchors capable of sustaining, without failure, a load equal to six times the load imposed when installed in unit masonry and four times the load imposed when installed in concrete, as determined by testing according to ASTM E 488/E 488M, conducted by a qualified independent testing agency.
 - 1. Material for Building Stairs: Carbon-steel components zinc plated to comply with ASTM B 633 or ASTM F 1941, Class Fe/Zn 5, unless otherwise indicated.
 - 2. Material for Tunnel Stairs: Alloy Group 1 stainless-steel bolts, ASTM F 593, and nuts, ASTM F 594.
- E. Nonslip-Aggregate Concrete Finish: Factory-packaged abrasive aggregate made from fused, aluminum-oxide grits or crushed emery; rustproof and nonglazing; unaffected by freezing, moisture, or cleaning materials.
- F. Welded Wire Reinforcement: ASTM A 1064, 6 by 6 inches W1.4 by W1.4, unless otherwise indicated.

2.4 FABRICATION, GENERAL

- A. Provide complete stair assemblies, including metal framing, railings, clips, brackets, bearing plates, and other components necessary to support and anchor stairs to steel framing at the Toll Administration Building or concrete tunnel at the toll plazas.
 - 1. Join components by welding unless otherwise indicated.
 - 2. Use connections that maintain structural value of joined pieces.
- B. Preassembled Stairs: Assemble stairs in shop to greatest extent possible. Disassemble units only as necessary for shipping and handling limitations. Clearly mark units for reassembly and coordinated installation.
- C. Cut, drill, and punch metals cleanly and accurately. Remove burrs and ease edges to a radius of approximately 1/32 inch unless otherwise indicated. Remove sharp or rough areas on exposed surfaces.
- D. Form bent-metal corners to smallest radius possible without causing grain separation or otherwise impairing work.
- E. Form exposed work with accurate angles and surfaces and straight edges.
- F. Weld connections to comply with the following:
 - 1. Use materials and methods that minimize distortion and develop strength and corrosion resistance of base metals.
 - 2. Obtain fusion without undercut or overlap.
 - 3. Remove welding flux immediately.
 - 4. Weld exposed corners and seams continuously unless otherwise indicated.
- G. Form exposed connections with hairline joints, flush and smooth, using concealed fasteners where possible. Where exposed fasteners are required, use Phillips flat-head

(countersunk) screws or bolts unless otherwise indicated. Locate joints where least conspicuous.

2.5 STEEL-FRAMED STAIRS

- A. NAAMM Stair Standard: Comply with "Recommended Voluntary Minimum Standards for Fixed Metal Stairs" in NAAMM AMP 510 unless more stringent requirements are indicated.
- B. Stair Framing:
 - 1. Fabricate stringers of steel channels.
 - a. Provide closures for exposed ends of channel stringers.
 - 2. Construct platforms of steel plate or channel headers and miscellaneous framing members as needed to comply with performance requirements.
 - 3. Weld or bolt stringers to headers; weld or bolt framing members to stringers and headers. If using bolts, fabricate and join so bolts are not exposed on finished surfaces.
- C. Metal Pan Stairs: Form risers, subtread pans, and subplatforms to configurations shown from steel sheet of thickness needed to comply with performance requirements, but not less than 0.067 inch.
 - 1. Steel Sheet at Toll Administration Building: Uncoated steel sheet.
 - 2. Steel Sheet at Tunnel Stairs: Galvanized-steel sheet.
 - 3. Directly weld metal pans to stringers; locate welds on top of subtreads where they are concealed by concrete fill. Do not weld risers to stringers.

2.6 STAIR RAILINGS

- A. Comply with applicable requirements in Section 05200 "Pipe and Tube Railings."
 - 1. Rails may be bent at corners, rail returns, and wall returns, instead of using prefabricated fittings.
 - 2. Connect posts to stair framing by direct welding unless otherwise indicated.
- B. Steel Tube Railings: Fabricate railings to comply with requirements indicated for design, dimensions, details, finish, and member sizes, including wall thickness of tube, post spacings, and anchorage, but not less than that needed to withstand indicated loads.
 - 1. Rails and Posts: 1-1/2-inch diameter rails.
- C. Welded Connections: Fabricate railings with welded connections. Cope components at connections to provide close fit, or use fittings designed for this purpose. Weld all around at connections, including at fittings.
 - 1. Finish welds to comply with NOMMA's "Voluntary Joint Finish Standards" for Type 1 welds: no evidence of a welded joint as shown in NAAMM AMP 521.

- D. Form changes in direction of railings as detailed on the Drawings.
 - 1. For changes in direction made by bending, use jigs to produce uniform curvature for each repetitive configuration required. Maintain cross section of member throughout entire bend without buckling, twisting, cracking, or otherwise deforming exposed surfaces of components.
- E. Brackets, Flanges, Fittings, and Anchors: Provide wall brackets, end closures, flanges, miscellaneous fittings, and anchors for interconnecting components and for attaching to other work. Furnish inserts and other anchorage devices for connecting to concrete or masonry work.
 - 1. At brackets and fittings fastened to plaster or gypsum board partitions, provide crush-resistant fillers or other means to transfer loads through wall finishes to structural supports and prevent bracket or fitting rotation and crushing of substrate.

2.7 FINISHES

- A. Finish metal stairs after assembly.
- B. Galvanizing at metal stairs within the tunnel shall be performed per the Special Provisions.
- C. Painting of metal stairs within the Toll Administration Building shall be performed per Specification 09900.
- D. Apply shop primer to uncoated surfaces of metal stair components, except those with galvanized finishes and those to be embedded in concrete or masonry unless otherwise indicated. Comply with SSPC-PA 1, "Paint Application Specification No. 1: Shop, Field, and Maintenance Painting of Steel," for shop painting.

PART 3 - EXECUTION

3.1 INSTALLING METAL PAN STAIRS

- A. Fastening to In-Place Construction: Provide anchorage devices and fasteners where necessary for securing metal stairs to in-place construction. Include threaded fasteners for concrete and masonry inserts, through-bolts, lag bolts, and other connectors.
- B. Cutting, Fitting, and Placement: Perform cutting, drilling, and fitting required for installing metal stairs. Set units accurately in location, alignment, and elevation, measured from established lines and levels and free of rack.
- C. Install metal stairs by welding stair framing to steel structure or to weld plates cast into concrete unless otherwise indicated.

- D. Provide temporary bracing or anchors in formwork for items that are to be built into concrete, masonry, or similar construction.
- E. Fit exposed connections accurately together to form hairline joints. Weld connections that are not to be left as exposed joints but cannot be shop welded because of shipping size limitations. Do not weld, cut, or abrade surfaces of exterior units that have been hot-dip galvanized after fabrication and are for bolted or screwed field connections.
- F. Field Welding: Comply with requirements for welding in "Fabrication, General" Article.
- G. Place and finish concrete fill for treads and platforms to comply with Section 03300 "Cast-in-Place Concrete."

3.2 INSTALLING RAILINGS

- A. Adjust railing systems before anchoring to ensure matching alignment at abutting joints. Space posts at spacing indicated on the Drawings or, if not indicated, as required by design loads.
- B. Attach handrails to wall construction as follows:
 - 1. For concrete anchorage, use expansion anchors.
 - 2. For steel-framed partitions, use hanger or lag bolts set into wood backing between studs. Coordinate with stud installation to locate backing members.

3.3 ADJUSTING AND CLEANING

- A. Touchup Painting: Immediately after erection, clean field welds, bolted connections, and abraded areas of shop paint, and paint exposed areas with same material as used for shop painting to comply with SSPC-PA 1 for touching up shop-painted surfaces.
 - 1. Apply by brush or spray to provide a minimum 2.0-mil dry film thickness.
- B. Galvanized Surfaces: Clean field welds, bolted connections, and abraded areas and repair galvanizing to comply with ASTM A 780/A 780M.

END OF SECTION

SECTION 05531

BAR GRATING

PART 1 – GENERAL

1.1 RELATED DOCUMENTS

- A. Examine Drawings, Contract Conditions all other Sections of the Specifications for requirements which affect work of this Section whether or not such work is specifically mentioned in this Section.
- B. Coordinate work with that of all other trades affecting, or affected by work of this Section. Cooperate with such trades to assure the steady progress of all Project work.

1.2 SUMMARY

- A. Section includes metal bar gratings.
- B. Related Requirements:
 - 1. Cast-In-Place Concrete – Section 03300 for installation of embedded support plates with shear studs.
 - 2. Metal Fabrications – Section 05500 for fabrication of embedded plates and shear studs.

1.3 COORDINATION

- A. Coordinate selection of shop primers with topcoats to be applied over them. Comply with paint and coating manufacturers' written instructions to ensure that shop primers and topcoats are compatible with one another.
- B. Coordinate installation of anchorages for gratings, grating frames, and supports. Furnish setting drawings, templates, and directions for installing anchorages, including sleeves, concrete inserts, anchor bolts, and items with integral anchors, that are to be embedded in concrete or masonry. Deliver such items to Project site in time for installation.

1.4 SUBMITTALS

- A. Product Data: For the following:
 - 1. Clips and anchorage devices for gratings.
- B. Shop Drawings: Include plans, sections, details, and attachments to other work.

- C. Mill Certificates: Signed by manufacturers of stainless steel certifying that products furnished comply with requirements.

1.5 FIELD CONDITIONS

- A. Field Measurements: Verify actual locations of walls and other construction contiguous with gratings by field measurements before fabrication.

PART 2 - MATERIALS

2.1 PERFORMANCE REQUIREMENTS

- A. Structural Performance: Gratings shall withstand the effects of gravity loads and the following loads and stresses within limits and under conditions indicated:
 1. Floors: Uniform load of 100 lbf/sq. ft. or concentrated load of 500 lbf, whichever produces the greater stress.
 2. Limit live load deflection to L/360 or 1/4 inch, whichever is less.

2.2 METAL BAR GRATINGS

- A. Metal Bar Grating Standards: Comply with NAAMM MBG 531, "Metal Bar Grating Manual."
- B. Welded Steel Grating: 19-W-4
 1. Bearing Bar Spacing: 1-3/16 inches
 2. Bearing Bar Depth: 2 inches
 3. Bearing Bar Thickness: 3/16 inch
 4. Crossbar Spacing: 4 inches o.c.
 5. Finish: Hot-dip galvanized with a coating weight of not less than 1.8 oz./sq. ft.

2.3 FERROUS METALS

- A. Steel Bars for Bar Gratings: ASTM A 36 or steel strip, ASTM A 1011 or ASTM A 1018.
- B. Wire Rod for Bar Grating Crossbars: ASTM A 510.
- C. Galvanized-Steel Sheet: ASTM A 653/A 653M, structural quality, Grade 33, with G90 coating.

2.4 FASTENERS

- A. Steel Bolts and Nuts: Regular hexagon-head bolts, ASTM A 307, Grade A; with hex nuts, ASTM A 563 and flat washers.

2.5 FABRICATION

- A. Shop Assembly: Fabricate grating sections in shop to greatest extent possible to minimize field splicing and assembly. Disassemble units only as necessary for shipping and handling limitations. Use connections that maintain structural value of joined pieces. Clearly mark units for reassembly and coordinated installation.
- B. Cut, drill, and punch material cleanly and accurately. Remove burrs and ease edges to a radius of approximately 1/32 inch unless otherwise indicated. Remove sharp or rough areas on exposed surfaces.
- C. Form from materials of size, thickness, and shapes indicated, but not less than that needed to support indicated loads.
- D. Fit exposed connections accurately together to form hairline joints.
- E. Welding: Comply with AWS recommendations and the following:
 - 1. Use materials and methods that minimize distortion and develop strength and corrosion resistance of base metals.
 - 2. Obtain fusion without undercut or overlap.
 - 3. Remove welding flux immediately.
- F. Removable Grating Sections: Fabricate with banding bars attached by welding to entire perimeter of each section. Include anchors and fasteners of type indicated below. All fasteners shall be hot-dipped galvanized.
 - 1. Provide no fewer than four weld lugs for each heavy-duty grating section, with each lug shop welded to two bearing bars.
 - 2. Furnish threaded bolts with nuts and washers for securing grating to supports.
- G. Do not notch bearing bars at supports to maintain elevation.

2.6 STEEL FINISHES

- A. Finish gratings, frames, and supports after assembly.
- B. Galvanizing: Hot-dip galvanize items as indicated to comply with ASTM A 153 for steel and iron hardware and with ASTM A 123 for other steel and iron products.
- C. Galvanizing Repair Paint: High-zinc-dust-content paint complying with SSPC-Paint 20 and compatible with paints specified to be used over it.

PART 3 - EXECUTION

3.1 INSTALLATION, GENERAL

- A. Fastening to In-Place Construction: Provide anchorage devices and fasteners where necessary for securing gratings to in-place construction. Include threaded fasteners for concrete and masonry inserts, through-bolts, lag bolts, and other connectors.
- B. Cutting, Fitting, and Placement: Perform cutting, drilling, and fitting required for installing gratings. Set units accurately in location, alignment, and elevation; measured from established lines and levels and free of rack.
- C. Provide temporary bracing or anchors in formwork for items that are to be built into concrete or masonry.
- D. Fit exposed connections accurately together to form hairline joints.

3.2 INSTALLING METAL BAR GRATINGS

- A. General: Install gratings to comply with recommendations of referenced metal bar grating standards that apply to grating types and bar sizes indicated, including installation clearances and standard anchoring details.
- B. Attach removable units to supporting members with type and size of clips and fasteners indicated or, if not indicated, as recommended by grating manufacturer for type of installation conditions shown.

3.3 ADJUSTING AND CLEANING

- A. Galvanized Surfaces: Clean field welds, bolted connections, and abraded areas and repair galvanizing to comply with ASTM A 780.

END OF SECTION

SECTION 06100

ROUGH CARPENTRY

PART 1 - GENERAL

1.01 RELATED DOCUMENTS

- A. Drawings, Contract Conditions and other Technical Specifications Sections apply to work of this Section insofar as applicable.
- B. Coordinate work with that of all other trades affecting, or affected by work of this Section. Cooperate with such trades to assure the steady progress of all Project work.

1.02 DESCRIPTION

- A. The work in this section consists of furnishing all materials, equipment, supplies, transportation, labor and supervision, and performing all operations required to perform all rough carpentry work as shown on the Drawings, as specified herein, and as is additionally necessary to properly complete the work. Work includes, but is not limited to, the following:
 - 1. Structural and rough wood framing.
 - 2. Roof trusses and roof framing, including all blocking, outriggers, etc.
 - 3. Soffit, fascia and rake framing.
 - 4. Rough hardware.
 - 5. Gable and overhang framing and sheathing.
 - 6. Roof sheathing.
 - 7. Insulation stops.
 - 8. Wood for other trades (i.e., blocking, nailers, grounds, etc.).
 - 9. Wood blocking required at back of fire extinguishers, electric panels, telephone panels, motor operators, wall stops, windows, toilet accessories, etc.
 - 10. Temporary protection as required.

1.03 SPECIFIED ELSEWHERE

- A. The installation of finish hardware is specified in Section 08700.

- B. Finish carpentry items such as soffits, cabinets, shelving, standing and running trim, exterior trim, window stools, etc., are specified in Section 06400.

1.04 SHOP DRAWINGS

- A. Submit copies of shop drawings and manufacturer's product data for approval.
- B. Submit shop drawings of trusses showing all necessary design details and calculations, stamped by a professional structural engineer licensed in the State of Maine. Also include jobsite storage instructions and details for a continuous insulation stop at all eaves. The Contractor shall furnish and install insulation stops even though they are not shown on the Resident's Drawings.
- C. Submit 18 inch long samples of wood to be used for each element (i.e., trusses, fasciae, rakes, etc.) for approval. Also submit 24 inch square samples of panel products and each rough hardware item (sheathing clips; metal hangers, straps and gussets; etc.) for approval.

1.05 GENERAL

- A. All lumber shall be new, dressed on all sides (S4S), and shall conform to U.S. Department of Commerce Simplified Practice Recommendation R16. Lumber for the various uses shall have characteristics appropriate for the intended use.
- B. All lumber and plywood in contact with the ground, concrete, or exposed to the weather shall be preservative treated as specified herein.
- C. Obtain measurements and verify dimensions shown on shop drawing details before proceeding with carpentry work, wherever possible.
- D. Correlate the location of furring, nailers, blocking, grounds and similar supports so that attached work will comply with design requirements.
- E. Fit carpentry work to other work. Scribe and cope as required for accurate fit.
- F. Time delivery and installation of carpentry work to avoid delaying other work which is dependent on or affected by the carpentry work and to comply with protection and storage requirements.
- G. Keep carpentry materials dry during transport and storage. Store lumber and plywood in stacks with provision for air circulation within stacks. Protect exposed materials against weather. Do not store dressed or treated lumber or plywood outdoors. Store trusses in accordance with the manufacturer's approved instructions and recommendations.

PART 2 - MATERIALS

2.01 STRUCTURAL FRAMING

- A. Structural framing, including plates, rafters, outlookers, bracing, blocking, etc., shall be kiln-dried Hem-Fir, No. 1 or better, free of loose knots and other defects that would impair its strength.

2.02 ROOF TRUSSES AND FRAMING

- A. The wood trusses and roof framing shall be designed and manufactured by Wood Structures, Inc., of Biddeford, Maine, or approved equal. The top and bottom cords of the trusses shall be a minimum of 2" x 6", as shown. (Coordinate with duct work which may impact the design of trusses and framing.) Provide gussets and extensions as indicated and required.
- B. The trusses shall be factory fabricated with adequate plant and under supervision of properly qualified personnel.
- C. The trusses shall be assembled with built-in camber and ready for site erection. All members shall be precision cut and assembled in a jig to ensure uniformity with all gusset plates accurately positioned.
- D. Metal gusset plates shall be 20 gauge hot-dip galvanized plates perforated with punched teeth. Plate design values shall be as approved by FHA.
- E. The fabricator of the trusses shall furnish steel connections and hardware for joining timber members to each other and to their supports exclusive of anchorages embedded in masonry. Such hardware shall conform to the details shown on the Drawings or the approved shop drawings. Hardware items shall have one coat of shop applied premium grade primer containing a rust inhibitor. All exposed connections to be hot-dip galvanized.

2.03 ROUGH HARDWARE

- A. Anchors, bolts, nuts, and miscellaneous metal items shall conform to requirements of Federal Specifications FF-B-575. Fastenings for exterior construction shall be hot-dip galvanized.
- B. Framing connectors, joist hangers, straps, metal bridging, etc., shall be as manufactured by TECO Timber Engineering Co., Heckman Building Products Inc., or Simpson Strong Tie Connectors, hot dip galvanized in accordance with ASTM A 123 or A 153, as applicable.

2.04 SHEATHING, DECKING AND MISCELLANEOUS PLYWOOD

- A. Sheathing shall be "Exterior" APA Performance - Rated Panels (C-D Exterior PS-1), 5/8 inch thick unless otherwise noted. Provide sheathing clips between panels for all

joint areas not over framing.

- B. Miscellaneous plywood for interior applications, such as electric panel backing boards, shall be Interior DFPA C-D with exterior glue.

2.05 SOFFITS, FASCIAE AND RAKES

- A. Fasciae, fasciae moldings, rakes, and rake moldings shall be preservative treated custom grade solid Hem-Fir selected for its clear appearance, free of loose knots, large knots, pitch streaks, cupping, etc., subject to approval by the Engineer, fabricated to the shapes shown on the Drawings.
- B. Soffits shall be sheathed with ½" thick preservative treated plywood prior to installation of PVC finish panels.

2.06 FURRING

- A. Furring shall be No. 1 Common Eastern Spruce of the sizes noted on the Drawings.

2.07 WOOD PRESERVATIVE

- A. Preservative Treatment: Lumber and plywood shall be treated with preservatives in compliance with applicable requirements of AWPB Standards C2 (Lumber) and C9 (Plywood) and of AWPB standards listed below. Mark each treated item with the AWPB Quality Mark.
 - 1. Pressure-treat above-ground items with water-borne preservatives complying with AWPB LP-2. After treatment, kiln-dry to a maximum moisture content of 15 percent. Treat indicated items and the following:
 - a. Wood cants, nailers, curbs, blocking, stripping, and similar members in connection with roofing, flashing, vapor retarders and waterproofing.
 - b. Wood sleepers, blocking, furring, stripping and similar concealed members in contact with masonry or concrete.
 - c. Wood framing members less than 18 inches above grade.
 - 2. Pressure-treat wood members in contact with ground with water-borne preservatives complying with AWPB LP-22:
 - 3. Complete fabrication of items to be treated prior to treatment, where possible. If members are cut, drilled or otherwise altered after treatment, coat the affected surfaces with two heavy brush coats of same chemical used for treatment. Inspect each piece of lumber or plywood after drying and discard damaged and defective pieces.

2.08 NAILS

- A. All nails for framing, sheathing, fasciae, gables and all other exterior applications shall

be "double" hot dipped galvanized equal to those provided by Maze Nails, Peru, IL.

PART 3 - EXECUTION

3.01 INSTALLATION

- A. Do all carpentry work required, lay out all lines, provide necessary measurements, and furnish all needed assistance in cooperation with the various trades to insure that the work is thoroughly and satisfactorily completed.
- B. Anchor framing members to timber, concrete, and masonry as indicated. All rough carpentry shall be laid out as called for on the Drawings. Cut framing square on bearings, closely fitted, accurately set to required lines and levels, plumb, and secured rigidly in place at bearings and connections.
- C. All carpentry shall be performed by workmen skilled in the trade. Lines shall be run true and accurate for support of finish carpentry and other applied finishes.
- D. Provide all temporary bracing as required. Maintain OSHA approved ladders at all times for convenient and safe access to all portions of the building.
- E. Set trusses plumb, straight and on accurate spacing as shown on the approved Shop Drawings. Use great care in erection to avoid flexing of trusses in the weak direction. Brace trusses temporarily with substantial bracing to prevent falling and distortion from wind and other causes.
- F. Frame members for passage of pipes and ducts to avoid cutting structural members. Do not cut, notch or bore members for passage of pipes or wiring without permission of the Resident. Reinforce framing members as directed where damaged or weakened by approved cutting.
- G. Nail or spike members in accordance with National Lumber Manufacturer's Association Manual for House Framing.
- H. Apply roof sheathing sheets with face grain perpendicular to the rafters and trusses. All end joints shall be on rafters/trusses and shall be staggered. Use a minimum of two (2) sheathing clips to join edges between trusses. Secure sheathing with 8d galvanized nails at 6 inch centers along panel edges, at 12 inch centers at intermediate trusses. Install floor decking in accordance with APA recommendations but with not less than one fastener 6 inches on center at edges and one fastener 12 inches on center over supports.
- I. Exterior woodwork shall be provided in the longest practicable lengths to minimize joints. Joints shall be hairline; mitered, scarfed or dadoed, as proposed by the Contractor and approved by the Resident. Joints in running material shall occur only over supports. Exposed mill ends are not acceptable. Drilled holes, cut-outs, cut edges

and ends, and other alterations made after preservative treatment shall be sealed before installation.

- K. Provide temporary wood protection for concrete, at trucking points, at entrances, over floor openings, at metal door bucks, and at finished woodwork and millwork, until completion and acceptance of the work.
- L. Provide temporary supports and wood centering as required.

END OF SECTION

SECTION 06175SHOP-FABRICATED WOOD TRUSSES

PART 1 – GENERAL

1.1 RELATED DOCUMENTS

- A. Examine Drawings, Contract Conditions all other Sections of the Specifications for requirements which affect work of this Section whether or not such work is specifically mentioned in this Section.
- B. Coordinate work with that of all other trades affecting, or affected by work of this Section. Cooperate with such trades to assure the steady progress of all Project work.

1.2 SUMMARY

- A. Section Includes:
 - 1. Wood roof trusses.
- B. Related Requirements:
 - 1. Rough Carpentry – Section 06100

1.3 DEFINITIONS

- A. Metal-Plate-Connected Wood Trusses: Planar structural units consisting of metal-plate-connected members fabricated from dimension lumber and cut and assembled before delivery to Project site.

1.4 SUBMITTALS

- A. Product Data: For wood-preservative-treated lumber, metal-plate connectors, metal truss accessories, and fasteners.
 - 1. Include data for wood-preservative treatment from chemical treatment manufacturer and certification from treating plant that treated materials comply with requirements. Indicate type of preservative used and net amount of preservative retained.
 - 2. For products receiving a waterborne treatment, include statement that moisture content of treated materials was reduced to levels specified before shipment to truss fabricator.
- B. Delegated-Design Submittal: Provide design calculations and shop drawings for metal-plate-connected wood trusses complying with performance requirements and design

criteria specified on the Drawings. Calculations and shop drawings shall be signed and sealed by a professional engineer licensed in the State of Maine.

- C. Shop Drawings: Show fabrication and installation details for trusses. Truss details shall include the information specified in IBC 2015, Article 2303.4.1.1 and the following:
 - 1. Show location, pitch, span, camber, configuration, and spacing for each type of truss required.
 - 2. Indicate sizes, stress grades, and species of lumber.
 - 3. Indicate locations, sizes, and materials for permanent bracing required to prevent buckling of individual truss members due to design loads.
 - 4. Indicate type, size, material, finish, design values, orientation, and location of metal connector plates.
 - 5. Show splice details and bearing details.
 - 6. Identify erection requirements including pick points, rigging and any temporary bracing requirements.
- D. Qualification Data: For metal connector-plate manufacturer, professional engineer, and fabricator.
- E. Material Certificates: For dimension lumber specified to comply with minimum specific gravity. Indicate species and grade selected for each use and specific gravity.
- F. Evaluation Reports: For the following, from ICC-ES:
 - 1. Metal-plate connectors.
 - 2. Metal truss accessories.
- G. Submit samples for approval.
 - 1. 18 inch long samples of wood to be used for trusses.
 - 2. Rough hardware items for metal-plate connectors, truss accessories, etc.

1.5 QUALITY ASSURANCE

- A. Metal Connector-Plate Manufacturer Qualifications: A manufacturer that is a member of TPI and that complies with quality-control procedures in TPI 1 for manufacture of connector plates.
 - 1. Manufacturer's responsibilities include providing professional engineering services needed to assume engineering responsibility.
 - 2. Engineering Responsibility: Preparation of Shop Drawings and comprehensive engineering analysis by a qualified professional engineer licensed in the State of Maine.
- B. Fabricator Qualifications:
 - 1. Shop that participates in a recognized quality-assurance program, complies with quality-control procedures in TPI 1, and involves third-party inspection by an

independent testing and inspecting agency acceptable to Engineer.

1.6 DELIVERY, STORAGE, AND HANDLING

- A. Handle and store trusses to comply with recommendations in SBCA BCSI, "Building Component Safety Information: Guide to Good Practice for Handling, Installing, Restraining, & Bracing Metal Plate Connected Wood Trusses."
 - 1. Store trusses flat, off of ground, and adequately supported to prevent lateral bending.
 - 2. Protect trusses from weather by covering with waterproof sheeting, securely anchored.
 - 3. Provide for air circulation around stacks and under coverings.
- B. Inspect trusses showing discoloration, corrosion, or other evidence of deterioration. Discard and replace trusses that are damaged or defective.

PART 2 - PRODUCTS

2.1 PERFORMANCE REQUIREMENTS

- A. Roof trusses shall be fabricated by one of the following companies:
 - a. Mainely Trusses, Inc. of Fairfield, ME
 - b. Aroostook Trusses, Inc. of Presque Isle, ME
 - c. Boise Structural Solutions of Biddeford, ME
- B. Delegated Design: Engage a professional engineer licensed in the State of Maine to design metal-plate-connected wood trusses.
- C. Structural Performance: Metal-plate-connected wood trusses shall be capable of withstanding design loads within limits and under conditions indicated. Comply with requirements in TPI 1 unless more stringent requirements are specified below.
- D. Comply with applicable requirements and recommendations of TPI 1, TPI DSB, and SBCA BCSI.
- E. Wood Structural Design Standard: Comply with applicable requirements in AF&PA's "National Design Specifications for Wood Construction" and its "Supplement."

2.2 DIMENSION LUMBER

- A. Lumber: DOC PS 20 and applicable rules of any rules-writing agency certified by the American Lumber Standard Committee (ALSC) Board of Review. Provide lumber graded by an agency certified by the ALSC Board of Review to inspect and grade lumber under the rules indicated.
 - 1. Factory mark each piece of lumber with grade stamp of grading agency.

2. Provide dry lumber with 15 percent maximum moisture content at time of dressing.

B. Minimum Chord Size for Roof Trusses: 2 by 6 inches nominal for both top and bottom chords.

2.3 METAL CONNECTOR PLATES

A. General: Fabricate connector plates to comply with TPI 1.

B. Hot-Dip Galvanized-Steel Sheet: ASTM A 653/A 653M; Structural Steel (SS), high-strength low-alloy steel Type A (HSLAS Type A), or high-strength low-alloy steel Type B (HSLAS Type B); G60 coating designation; and not less than 0.036 inch thick.

1. Use for interior locations unless otherwise indicated.

2.4 FASTENERS

A. General: Provide fasteners of size and type indicated that comply with requirements specified in this article for material and manufacture.

1. Provide fasteners for use with metal framing anchors that comply with written recommendations of metal framing manufacturer.

B. Nails, Brads, and Staples: ASTM F 1667.

2.5 METAL FRAMING ANCHORS AND ACCESSORIES

A. Galvanized-Steel Sheet: Hot-dip, zinc-coated steel sheet complying with ASTM A 653/A 653M, G60 coating designation.

1. Use for interior locations unless otherwise indicated.

B. Truss Tie-Downs (Hurricane or Seismic Ties): Provide two Simpson, H-2.5A ties, or approved equals at truss end connections to sill plates.

1. Each tie-down shall provide a minimum allowable uplift capacity of 535 lbs.

2.6 MISCELLANEOUS MATERIALS

A. Galvanizing Repair Paint: SSPC-Paint 20, with dry film containing a minimum of 92 percent zinc dust by weight.

2.7 FABRICATION

A. Cut truss members to accurate lengths, angles, and sizes to produce close-fitting joints.

- B. Fabricate metal connector plates to sizes, configurations, thicknesses, and anchorage details required to withstand design loads for types of joint designs indicated.
- C. Assemble truss members in design configuration indicated; use jigs or other means to ensure uniformity and accuracy of assembly, with joints closely fitted to comply with tolerances in TPI 1. Position members to produce design camber indicated.
 - 1. Fabricate wood trusses within manufacturing tolerances in TPI 1.
- D. Connect truss members by metal connector plates located and securely embedded simultaneously in both sides of wood members by air or hydraulic press.

PART 3 - EXECUTION

3.1 INSTALLATION

- A. Install wood trusses only after supporting construction is in place and is braced and secured.
- B. If trusses are delivered to Project site in more than one piece, assemble trusses before installing.
- C. Hoist trusses in place by lifting equipment suited to sizes and types of trusses required, exercising care not to damage truss members or joints by out-of-plane bending or other causes.
- D. Install and brace trusses according to TPI recommendations and as indicated.
- E. Install trusses plumb, square, and true to line and securely fasten to supporting construction.
- F. Space trusses 24 inches o.c.; adjust and align trusses in location before permanently fastening.
- G. Anchor trusses securely at bearing points; use metal truss tie-downs. Install fasteners through each fastener hole in metal framing anchors according to manufacturer's fastening schedules and written instructions.
- H. Install and fasten permanent bracing during truss erection and before construction loads are applied.
- I. Install wood trusses within installation tolerances in TPI 1.
- J. Do not alter trusses in field. Do not cut, drill, notch, or remove truss members.
- K. Replace wood trusses that are damaged or do not comply with requirements.

1. Damaged trusses may be repaired according to truss repair details signed and sealed by the qualified professional engineer responsible for truss design, when approved by Architect.

3.2 REPAIRS AND PROTECTION

- A. Protect wood trusses from weather. If, despite protection, wood trusses become wet, apply EPA-registered borate treatment. Apply borate solution by spraying to comply with EPA-registered label.
- B. Repair damaged galvanized coatings on exposed surfaces according to ASTM A 780 and manufacturer's written instructions.

END OF SECTION

SECTION 06400

FINISH CARPENTRY

PART 1 - GENERAL

1.01 RELATED DOCUMENTS

- A. Drawings, Contract Conditions and other Technical Specifications Sections apply to work of this Section insofar as applicable.
- B. Coordinate work with that of all other trades affecting, or affected by work of this Section. Cooperate with such trades to assure the steady progress of all Project work.

1.02 DESCRIPTION

- A. Finish carpentry work is shown on Drawings.
- B. Finish carpentry work includes, but is not limited to the following:
 - 1. Composite PVC standing and running trim and sills at windows
 - 2. Composite PVC panel soffits with soffit vents.
 - 3. Composite PVC exterior standing and running trim.

1.03 SUBMITTALS

- A. Product Data: Submit eight (8) copies of manufacturer's specifications and installation instructions for each product required.
- B. Shop Drawings: Submit eight (8) copies of shop drawings showing location of each item, dimensioned plans and elevations, large scale details, installation procedures and requirements, attachment devices and other components.
- C. Samples: Submit the following samples for each species and cut or pattern of architectural woodwork:
 - 1. Composite PVC trim for opaque finish; 6" x 3/4" x 18".
 - 2. Plywood for painted finish (including edge banding), 1 finished sample of each type, 12 inches' square.
 - 3. Composite PVC soffit panels for opaque finish; 6" x 1/2" x 12". Include PVC trim accessories for joining panels.

1.06 PRODUCT DELIVERY, STORAGE AND HANDLING

Protect finish carpentry products during transit, delivery, storage and handling to prevent damage, soiling and deterioration.

1.07 WORK NOT INCLUDED

A. Finishing of standing and running trim is specified in Section 09900.

PART 2 - MATERIALS

2.01 BASIC MATERIALS AND FABRICATION METHODS

A. Except as otherwise indicated, comply with following requirements for architectural woodwork not specifically indicated as prefabricated or prefinished standard products.

B. Wood Moisture Content: Provide kiln-dried (KD) lumber with an average moisture content range of 9% to 12% for interior work; 15% for exterior. Maintain temperature and relative humidity during fabrication, storage and finishing operations.

C. Interior Wood and PVC:

1. Concealed Solid Wood: Ponderosa Pine, Sugar Pine or Idaho Pine; No. 2 or better.
2. Interior Plywood - Painted Finish: Interior grade A-B DFPA Douglas fir with matching edge bands where edges are exposed.
3. Interior Composite PVC Trim – Painted Finish: Azek Trim, or similar as approved by Architect.
4. Interior Composite PVC Panel – Painted Finish: Azek Sheet, or similar as approved by the Architect.

F. Exterior PVC

1. Composite PVC Soffits - Painted Finish: Azek Sheet, or similar as approved by the Architect.
2. Composite PVC Trim - Painted Finish: Azek Trim, or similar as approved by the Architect.
3. PVC Accessories – “H” profile trim units for butting end joints of panels.

G. Soffit Vents: Soffit vents shall be aluminum "Vent-a-Strip", Model 70 as manufactured by H.C. Products, Co., or approved equal.

- H. Design and Construction Features: Comply with details shown for profile and construction of finish carpentry; and, where not otherwise shown, comply with applicable Quality Standards, with alternate details at the fabricator's option.

PART 3 - EXECUTION

3.01 PREPARATION

- A. Condition finish carpentry to average prevailing humidity conditions in installation areas prior to installing.
- B. Meet at the site prior to delivery of finish carpentry and review coordination and environmental controls required for proper installation and ambient conditioning in areas to receive work. Include in meeting the Contractor, Resident and other Authority representatives; installers, painting, mechanical work and electrical work, and firms or persons responsible for continued operation (whether temporary or permanent) of HVAC system as required to maintain temperature and humidity conditions. Proceed with installation only when everyone concerned agrees that required ambient conditions can be properly maintained.
- C. Deliver inserts and similar anchoring devices to be built into substrates well in advance of time substrates are to be built.
- D. Prior to installation of, examine shop fabricated work for completion, and complete work as required, including back priming and removal of packing.

3.02 INSTALLATION OF WOODWORK

- A. Install the work plumb, level, true and straight with no distortions. Shim as required using concealed shims. Install to a tolerance of 1/8 inch in 8'-0" for plumb and level (including countertops); 1/16-inch maximum offset in flush adjoining surfaces; and 1/8 inch maximum offsets in revealed adjoining surfaces.
- B. Scribe and cut work to fit adjoining work and refinish cut surfaces or repair damaged finish at cuts.
- C. Anchor finish carpentry to anchors or blocking built-in or directly attached to substrates. Secure to grounds, stripping and blocking with countersunk, concealed fasteners and blind nailing as required for a complete installation. Except where prefinished matching fastener heads are required, use fine finishing nails for exposed nailing's, countersunk and filled flush with woodwork, and matching final finish where transparent finish is indicated.
- D. Standing and Running Trim: Install with minimum number of joints possible, using full-length pieces (from maximum length of lumber available) to the greatest extent possible. Stagger joints in adjacent and related members. Cope at returns, miter at corners, and comply with Quality Standards for joinery.

3.03 INSTALLATION OF EXTERIOR SOFFITS & TRIM

All exterior soffits and trim shall be mitered to tight, hair-line joints and shall be back and edge sealed with clear sealer after all cuts are made (including those for soffit vents) and before installation. Joints in running material shall occur only at supports. Prior to installing, surfaces that will be inaccessible after installation shall be thoroughly back-primed. Fasteners shall be set below the finish surface and the holes filled and sanded smooth. Butted soffit panels shall have PVC "H" channels at seams with concealed fasteners.

3.04 ADJUSTMENT, CLEANING, FINISHING AND PROTECTION

- A. Repair damaged and defective work to eliminate functional and visual defects. Where it is not possible to repair items to the Resident's satisfaction, replace the work at no additional cost. Adjust joinery for uniform appearance.
- B. Lubricate, make final adjustments for proper operation, and clean hardware.
- C. Clean composite PVC exposed and semi-exposed surfaces. Touch-up finishes to restore damaged or soiled areas to the Engineer's satisfaction.
- D. Refer to Section 09900 for final finishing of installed finish carpentry work and architectural woodwork.
- E. Protection:
 - 1. Protect finish carpentry during the remainder of the construction period to ensure that work will be without damage or deterioration at time of acceptance.
 - 2. Cover completed work with protective covering as necessary to protect from damage, applied in a manner which will allow easy removal without damaging finish carpentry, or adjoining work. Remove coverings immediately before Final Acceptance.

END OF SECTION

SECTION 07200

INSULATION

PART 1 – GENERAL

1.1 RELATED DOCUMENTS

- A. Drawings, Contract Conditions and other Technical Specifications Sections apply to work of this Section insofar as applicable.
- B. Coordinate work with that of all other trades affecting, or affected by work of this Section. Cooperate with such trades to assure the steady progress of all Project work.

1.2 DESCRIPTION

- A. The work includes furnishing of all labor and materials necessary to provide an installation which is complete in every respect and of the composition and quality as specified herein.
- B. Applications of insulation specified in this section include, but are not limited to, the following:
 - 1. Board type for perimeter slab and foundation walls.
 - 2. Board type for masonry cavity walls.
 - 3. Spray foam type for sealing around mechanical and electrical penetrations.
 - 4. Batt type insulation at the bottom chords of roof trusses.
 - 5. Loose masonry insulation for CMU voids.
- C. The work also includes furnishing and installing polyethylene vapor retarders.

1.3 QUALITY ASSURANCE

- A. Thermal Resistance: Where a minimum "R" value is given, provide thickness required to achieve indicated value.
- B. Thermal Transmittance-Heat Transfer: Where a maximum "U" value is given for a wall assembly, provide thickness required to achieve indicated value.
- C. Fire and Insurance Ratings: Comply with fire-resistance, flammability and insurance ratings indicated, and comply with regulations as interpreted by applicable codes and local authorities.

1.4 SUBMITTALS

- A. Product Data: Submit eight (8) copies of the manufacturers' specifications and installation instructions for each type of insulation and vapor barrier material required.
- B. Certified Tests: Submit eight (8) copies of certified test report showing compliance with specified performance values if submitted product is other than those specified.

1.5 PRODUCT HANDLING

Protect insulation from sunlight, from physical damage and from becoming wet, soiled, or covered with ice and snow. Comply with manufacturers' recommendations for handling, storage and protection during installation.

PART 2 - MATERIALS

2.1 MANUFACTURERS

Available Manufacturers: Subject to compliance with requirements, manufacturers offering products which may be incorporated in the work include, but are not limited to those listed below.

2.2 MATERIALS

- A. Extruded Polystyrene Board Insulation: Rigid, closed-cell, extruded, polystyrene insulation board with integral high-density skin; comply with ASTM C 578, Type IV, achieve minimum compressive strength of 25 psi at 10% deformation per ASTM D 1621; achieve maximum moisture absorption of 0.3% by volume per ASTM C 272; 5-year aged R-value of 5 per inch at 75°F.

"SM", "TG" or "RM", Dow Chemical Co.
Formula 400, UC Industries/U.S. Gypsum

Expanded polystyrene insulation board is not acceptable.

- B. Unfaced Glass Fiber Batt Insulation: Thermal insulation produced by combining glass fibers with thermosetting resins to comply with ASTM C 665 for Type I and ASTM E 136.
- C. Concrete Masonry Unit Insulation: Shall be loose fill vermiculite insulation treated for water repellency, conforming to ASTM C 516, Type II, equal to "Zonolite Masonry Insulation" by W.R. Grace & Co.
- D. Spray Foam Insulation: Shall be "Great Stuff" by Dow Chemical Company, or similar as approved by the Architect.

- E. Adhesive for Bonding Insulation: Type recommended by insulation manufacturer and complying with fire-resistance requirements.
- F. Mechanical Anchors: Type and size, as recommended by insulation manufacturer for conditions of application and substrates.
- G. Mastic Sealer: Type recommended by insulation manufacturer for bonding edge joints between units and filling voids in work.
- H. Vapor Retarder: 6 mil polyethylene film with laboratory tested vapor transmission rating of 0.2 perms, natural color. Provide manufacturer recommended, Engineer approved tape for sealing laps.

PART 3 - EXECUTION

3.1 INSPECTION AND PREPARATION

Examine substrate and conditions under which insulation work is to be performed and notify the Engineer in writing of unsatisfactory conditions. Do not proceed with insulation work until unsatisfactory conditions have been corrected in an acceptable manner.

Clean substrates of substances harmful to insulations (or vapor barriers, including removal of projections which might puncture vapor barriers).

3.2 INSTALLATION OF INSULATION

- A. Comply with manufacturers' instructions for installation or consult manufacturer's technical representative for specific recommendations before proceeding with work.
- B. Apply insulation (full thickness) over entire area to be insulated. Cut and fit tightly around obstructions, and fill voids with insulation, taking care not to overly compress the insulation. Remove projections which interfere with placement.
- C. Under-slab Insulation

Set units in accordance with the manufacturer's instructions and recommendations and protect from damage.
- D. Cavity-Wall and Foundation Insulation:

Install polystyrene insulation board with globs of adhesive as recommended by manufacturer. Fit closely around reinforcing and obstructions, with all edges butted tightly.

Seal joints between insulation units by applying mastic to edges of each unit to form a tight seal as units are shoved into place. Fill voids in completed installation and around penetrations with mastic or approved sealant.

- E. Loose CMU and Spray Foam Insulation: Install in strict accordance with the manufacturers' instructions.

3.3 INSTALLATION OF VAPOR RETARDER

- A. Extend vapor retarder to extremities of areas to be protected from vapor transmission. Secure in place with adhesives or other anchorage system as approved by the Engineer. Extend vapor retarder to cover miscellaneous voids in insulation substrates.
- B. Seal vertical joints in vapor retarders over framing by lapping not less than 2 wall studs. Fasten vapor retarders to framing at top, end and bottom edges, at perimeter of wall openings and at lap joints in a manner acceptable to the Resident; space fasteners 16 inches on center. After retarder has been fastened, cover fasteners and lap joint with approved tape.

3.4 PROTECTION

Protect installed insulation and vapor retarders from harmful weather exposures and from physical abuse. Installer shall advise Contractor of exposure hazards, including possible sources of deterioration and fire hazards.

END OF SECTION

SECTION 07531

ETHYLENE-PROPYLENE-DIENE-MONOMER (EPDM) ROOFING

PART 1 - GENERAL

1.1 SUMMARY

A. Section Includes:

1. Adhered ethylene-propylene-diene-monomer (EPDM) roofing system.
2. Roof insulation.

1.2 DEFINITIONS

- A. Roofing Terminology: Definitions in ASTM D 1079 and glossary of NRCA's "The NRCA Roofing and Waterproofing Manual" apply to work of this Section.

1.3 PREINSTALLATION MEETINGS

- A. Pre-installation Roofing Conference: Conduct conference at Project Site.

1.4 ACTION SUBMITTALS

- A. Product Data: For each type of product.

B. LEED Submittals:

1. Product Test Reports for Credit SS 7.2: For roof materials, documentation indicating that roof materials comply with Solar Reflectance Index requirement.
2. Product Data for Credit IEQ 4.1: For adhesives and sealants used inside the weatherproofing system, documentation including printed statement of VOC content.
3. Laboratory Test Reports for Credit IEQ 4.1: For adhesives and sealants used inside the weatherproofing system, documentation indicating that products comply with the testing and product requirements of the California Department of Public Health's (formerly, the California Department of Health Services') "Standard Method for the Testing and Evaluation of Volatile Organic Chemical Emissions from Indoor Sources Using Environmental Chambers."

- C. Shop Drawings: For roofing system. Include plans, elevations, sections, details, and attachments to other work.

- D. Samples for Verification: For the following products:

1. Sheet roofing, of color required.

1.5 INFORMATIONAL SUBMITTALS

- A. Research/Evaluation Reports: For components of roofing system, from ICC-ES.
- B. Sample Warranties: For manufacturer's special warranties.

1.6 CLOSEOUT SUBMITTALS

- A. Maintenance Data: For roofing system to include in maintenance manuals.

1.7 QUALITY ASSURANCE

- A. Installer Qualifications: A qualified firm that is approved, authorized, or licensed by roofing system manufacturer to install manufacturer's product and that is eligible to receive manufacturer's special warranty.

1.8 WARRANTY

- A. Special Warranty: Manufacturer agrees to repair or replace components of roofing system that fail in materials or workmanship within specified warranty period.
 - 1. Warranty Period: 20 years from date of Substantial Completion.

PART 2 - PRODUCTS

2.1 MANUFACTURERS

- A. Source Limitations: Obtain components including roof insulation, fasteners, for roofing system from same manufacturer as membrane roofing.

2.2 PERFORMANCE REQUIREMENTS

- A. Accelerated Weathering: Roofing system shall withstand 2000 hours of exposure when tested according to ASTM G 152, ASTM G 154, or ASTM G 155.
- B. Impact Resistance: Roofing system shall resist impact damage when tested according to ASTM D 3746 or ASTM D 4272.
- C. Roofing System Design: Manufacturer shall be responsible for qualified testing agency to test for resistance to uplift pressures.
- D. Retain "Solar Reflectance Index," "Energy Star Listing," or "Energy Performance" Paragraph below if "cool-roof" performance is required. Verify that EPDM roofing specified complies before retaining.

- E. Exterior Fire-Test Exposure: ASTM E 108 or UL 790, Class A for application and roof slopes indicated; testing by a qualified testing agency. Identify products with appropriate markings of applicable testing agency.
- F. Fire-Resistance Ratings: Comply with fire-resistance-rated assembly designs indicated. Identify products with appropriate markings of applicable testing agency.

2.3 EPDM ROOFING

- A. EPDM: ASTM D 4637, uniform, flexible EPDM sheet.

1. Basis-of-Design Product:
 - a. Carlisle SynTec Incorporated.
 - b. ERSystems.
 - c. Firestone Building Products.
 - d. GAF Materials Corporation.
 - e. GenFlex Roofing Systems.
 - f. International Diamond Systems.
 - g. Johns Manville.
 - h. Lexcan Limited.
 - i. Mule-Hide Products Co., Inc.
 - j. Roofing Products International, Inc.
 - k. StaFast Building Products.
 - l. Versico Incorporated.
2. Thickness: 60 mils (1.5 mm)

2.4 AUXILIARY ROOFING MATERIALS

- A. General: Auxiliary materials recommended by roofing system manufacturer for intended use and compatible with roofing.
- B. Sheet Flashing: 60-mil- (1.5-mm-) thick EPDM, partially cured or cured, according to application.
- C. Protection Sheet: Epichlorohydrin or neoprene nonreinforced flexible sheet, 55- to 60-mil- (1.4- to 1.5-mm-) thick, recommended by EPDM manufacturer for resistance to hydrocarbons, non-aromatic solvents, grease, and oil.
- D. Bonding Adhesive: Manufacturer's standard.
- E. Seaming Material: Manufacturer's standard.
- F. Fasteners: Factory-coated steel fasteners and metal or plastic plates complying with corrosion-resistance provisions in FM Global 4470, designed for fastening membrane to substrate, and acceptable to roofing system manufacturer.
- G. Miscellaneous Accessories: Provide lap sealant, water cutoff mastic, metal termination bars, metal battens, pourable sealers, preformed cone and vent sheet flashings, molded

pipe boot flashings, preformed inside and outside corner sheet flashings, reinforced EPDM securement strips, T-joint covers, in-seam sealants, termination reglets, cover strips, and other accessories.

2.5 SUBSTRATE BOARDS

A. Substrate Board: ASTM C 1177/C 1177M, glass-mat, water-resistant gypsum substrate Type X, 5/8 inch (16 mm) thick.

1. Products:

- a. CertainTeed Corporation
- b. Georgia-Pacific Corporation
- c. National Gypsum Company
- d. Temple-Inland, Inc
- e. USG Corporation

2.6 ROOF INSULATION

A. Extruded-Polystyrene Board Insulation: ASTM C 578, minimum density, square edged.

1. Basis-of-Design Product:

- a. DiversiFoam Products.
- b. Dow Chemical Company (The).
- c. Owens Corning.
- d. Pactiv Corporation.

B. Tapered Insulation: Provide factory-tapered insulation boards fabricated to slope of [1/4 inch per 12 inches (1:48)] unless otherwise indicated.

C. Provide preformed saddles, crickets, tapered edge strips, and other insulation shapes where indicated for sloping to drain. Fabricate to slopes indicated.

2.7 INSULATION ACCESSORIES

A. Fasteners: Factory-coated steel fasteners and metal or plastic plates complying with corrosion-resistance designed for fastening roof insulation **and cover boards** to metal roof deck substrate, and acceptable to roofing system manufacturer.

B. Insulation Adhesive: Insulation manufacturer's recommended adhesive formulated to attach roof insulation to substrate or to another insulation layer.

C. Cover Board installed over metal roof deck: ASTM C 1177/C 1177M, glass-mat, water-resistant gypsum substrate, 5/8 inch (16 mm)] thick, factory primed.

1. Products:

- a. CertainTeed Corporation; GlasRoc Sheathing Type X

- b. Georgia-Pacific Corporation; Dens Deck Prime .
- c. National Gypsum Company; Gold Bond eXP Extended Exposure Sheathing.
- d. Temple-Inland, Inc; GreenGlass Exterior Sheathing.
- e. USG Corporation; Securock Glass Mat Roof Board.

PART 3 - EXECUTION

3.1 ROOFING INSTALLATION, GENERAL

- A. Install roofing system according to roofing system manufacturer's written instructions.
- B. Complete terminations and base flashings and provide temporary seals to prevent water from entering completed sections of roofing system at the end of the workday or when rain is forecast. Remove and discard temporary seals before beginning work on adjoining roofing.

3.2 SUBSTRATE BOARD INSTALLATION

- A. Install substrate board with long joints in continuous straight lines, perpendicular to roof slopes with end joints staggered between rows. Tightly butt substrate boards together.
 - 1. Fasten substrate board to top flanges of steel deck to resist uplift pressure at corners, perimeter, and field of roof according to roofing system manufacturers' written instructions.

3.3 INSULATION INSTALLATION

- A. Coordinate installing roofing system components so insulation is not exposed to precipitation or left exposed at the end of the workday.
- B. Install tapered insulation under area of roofing to conform to slopes indicated.
- C. Install insulation under area of roofing to achieve required thickness. Where overall insulation thickness is 2.7 inches (68 mm) or greater, install two or more layers with joints of each succeeding layer staggered from joints of previous layer a minimum of 6 inches (150 mm) in each direction.
 - 1. Where installing composite and noncomposite insulation in two or more layers, install noncomposite board insulation for bottom layer and intermediate layers, if applicable, and install composite board insulation for top layer.
- D. Mechanically Fastened and Adhered Insulation: Install first layer of insulation to deck using mechanical fasteners specifically designed and sized for fastening specified board-type roof insulation to deck type.

1. Fasten first layer of insulation to resist uplift pressure at corners, perimeter, and field of roof.
2. Set each subsequent layer of insulation in a solid mopping of hot roofing asphalt, applied within plus or minus 25 deg F (14 deg C) of equiviscous temperature.
3. Set each subsequent layer of insulation in insulation adhesive, firmly pressing and maintaining insulation in place.

3.4 ADHERED MEMBRANE ROOFING INSTALLATION

- A. Adhere roofing over area to receive roofing according to membrane roofing system manufacturer's written instructions. Unroll membrane roofing and allow to relax before installing.
- B. Accurately align roofing, and maintain uniform side and end laps of minimum dimensions required by manufacturer. Stagger end laps.
- C. Bonding Adhesive: Apply to substrate and underside of roofing at rate required by manufacturer, and allow to partially dry before installing roofing. Do not apply to splice area of roofing.
- D. In addition to adhering, mechanically fasten roofing securely at terminations, penetrations, and perimeters.
- E. Adhesive Seam Installation: Clean both faces of splice areas, apply splicing cement, and firmly roll side and end laps of overlapping roofing according to manufacturer's written instructions to ensure a watertight seam installation. Apply lap sealant and seal exposed edges of roofing terminations.
 1. Apply a continuous bead of in-seam sealant before closing splice if required by roofing system manufacturer.
- F. Tape Seam Installation: Clean and prime both faces of splice areas, apply splice tape, and firmly roll side and end laps of overlapping roofing according to manufacturer's written instructions to ensure a watertight seam installation. Apply lap sealant and seal exposed edges of roofing terminations.
- G. Repair tears, voids, and lapped seams in roofing that do not comply with requirements.
- H. Spread sealant or mastic bed over deck-drain flange at roof drains, and securely seal membrane roofing in place with clamping ring.

3.5 BASE FLASHING INSTALLATION

- A. Install sheet flashings and preformed flashing accessories, and adhere to substrates according to roofing system manufacturer's written instructions.
- B. Apply bonding adhesive to substrate and underside of sheet flashing at required rate, and allow to partially dry. Do not apply to seam area of flashing.

- C. Flash penetrations and field-formed inside and outside corners with cured or uncured sheet flashing.
- D. Clean splice areas, apply splicing cement, and firmly roll side and end laps of overlapping sheets to ensure a watertight seam installation. Apply lap sealant and seal exposed edges of sheet flashing terminations.
- E. Terminate and seal top of sheet flashings and mechanically anchor to substrate through termination bars.

3.6 PROTECTING AND CLEANING

- A. Protect membrane roofing system from damage and wear during remainder of construction period. When remaining construction does not affect or endanger roofing, inspect roofing for deterioration and damage, describing its nature and extent in a written report, with copies to Architect and Owner.
- B. Correct deficiencies in or remove membrane roofing system that does not comply with requirements, repair substrates, and repair or reinstall membrane roofing system to a condition free of damage and deterioration at time of Substantial Completion and according to warranty requirements.
- C. Clean overspray and spillage from adjacent construction using cleaning agents and procedures recommended by manufacturer of affected construction.

END OF SECTION

SECTION 07600

FLASHING AND SHEET METAL

PART 1 - GENERAL

1.1 RELATED DOCUMENTS

- A. Drawings, Contract Conditions and other Technical Specifications Sections apply to work of this Section insofar as applicable.
- B. Coordinate work with that of all other trades affecting, or affected by work of this Section. Cooperate with such trades to assure the steady progress of all Project work.

1.2 DESCRIPTION

- A. The work in this section consists of furnishing all materials, equipment, transportation, labor and supervision, and performing all operations required to provide all sheet metal work including crickets as shown on the Drawings, as specified herein, and as is additionally required to properly complete the work.

1.3 SPECIFIED ELSEWHERE

- A. Ductwork is specified under Section 15800 "Ductwork and Accessories".

1.4 GENERAL REQUIREMENTS

- A. All sheet metal shall have the manufacturer's trade name and thickness or weight marked on each sheet.
- B. Surface to which sheet metal is to be applied shall be even, smooth, sound, thoroughly clean, dry and free from all defects that might affect the installation. Materials furnished under this section which are to be built in by others shall be delivered to the site in time to avoid delays in construction progress. All cutting, fitting, drilling, and other operations in connection with sheet metal required to accommodate the work of other trades shall be performed under this section. All accessories and other related items not specifically shown or specified also shall be provided under this section.
- C. During construction, care shall be taken to prevent damage to roofing and flashing in place by not walking over or placing materials on or against them.

1.5 SUBMITTALS

- A. Submit samples of all materials and copies of pertinent literature for approval before proceeding with the work.
- B. Submit Shop Drawings detailing all flashing installations.

PART 2 - MATERIALS

2.1 MATERIALS

- A. All copper shall be cold-rolled, 16 oz. lead-coated, as detailed or noted on the Drawings and specified herein.
- B. Nails and other accessories used for fastening copper shall be copper, bronze or brass of the required sizes.
- C. Solder shall be 40 percent pig lead and 60 percent block tin. Flux shall be muriatic acid killed with zinc, or an approved brand of soldering paste.

PART 3 - EXECUTION

3.1 INSTALLATION

All work shall be as shown on the Drawings, performed in strict compliance with the recommended practice and standard specifications of the Copper and Brass Research Association and "Copper and Common Sense" as published by Revere Copper and Brass.

END OF SECTION

SECTION 07610METAL ROOFING

PART 1 - GENERAL

1.1 RELATED DOCUMENTS

- A. Examine all other Sections of the Specifications for requirements which affect work of this Section whether or not such work is specifically mentioned in this Section.
- B. Coordinate work with that of all other trades affecting, or affected by work of this Section. Cooperate with such trades to assure the steady progress of all Project work.

1.2 DESCRIPTION

- A. The Contractor shall design, engineer and furnish all materials, equipment, supplies, tools, labor and supervision, and shall perform all work required for the complete installation of weathertight structural standing seam aluminum-zinc alloy coated steel roofing systems for the Building, complete with matching accessories and appurtenances as shown on the Contract Drawings, as specified herein, as required and recommended by the roofing system manufacturer and approved by the Engineer, and as is additionally required for the proper completion of the work, including but not limited: providing a continuous panel anchorage system, waterproofing membrane, expansion joint, crickets, edge treatments, trim closures, penetration flashing, base and cap flashings, transition flashings, miscellaneous flashings, fasteners, sealants, snow guards, etc.

Note: The Contract Drawings depict the design concept and the basic relationship of the various roofs to each other and to other surrounding construction. The metal roofing system shown on the Contract Drawings is a high profile, wide spaced batten system. However, the roof to be provided under this Contract shall be a structural standing seam metal roof as described hereinafter. Edge conditions, flashings, etc., shall remain as shown except where different details are proposed by the roofing system manufacturer to accommodate their particular roofing system and such changes are accepted by the Engineer.

It shall be understood that it is solely the Contractor's responsibility to fully inspect and investigate all conditions affecting the proper installation of the standing seam metal roofing system required, and to insure that all conditions are suitably provided for in the manufacture, fabrication and installation of the roofing system regardless of what may be shown/specified or not shown/specified on the Contract Drawings or in the specifications. The aesthetic requirements shown on the Contract Drawings, other than batten spacing, the requirements of these specifications, and the preferred recommendations of the roofing system manufacturer, as approved by the Resident, shall be complied with in all instances, at no additional cost to the Authority. In case of conflict between requirements, the more stringent and costly requirement, as determined solely by the Resident, shall apply.

Therefore, it is incumbent on the Contractor to review the Contract Work in detail with the proposed roofing system manufacturer(s) prior to submitting a bid for the Contract work.

Single panels with proper lap at intersections shall be use for each slope to cover the perimeter of the roof. Submit Shop Drawings for approval.

- B. Flashing and sheet metal required for the work of this Section, such as for edge conditions and penetration flashings, shall match the roofing and shall be provided in accordance with the requirements of the roofing system manufacturer's approved Shop Drawings and installation instructions.
- C. Joint sealer work that is required to make the roofing installation watertight and weathertight with abutting construction shall be performed as part of the work of this Section in accordance with the, roofing system manufacturer's approved Shop Drawings and installation instructions.

1.3 SUBMITTALS

- A. Shop Drawings: As noted above, the Contract Drawings depict the design concept and the basic relationship of the various roofs to each other and to surrounding construction based on a high profile, wide spaced batten system. It is solely the responsibility of the Contractor to have the proposed roofing system manufacture develop detailed Shop Drawings to properly adapt the proposed roof system to all Project conditions. Shop Drawings shall include but not be limited to: layouts of vapor retarder, waterproofing membrane, and roofing panels, and full scale plans, elevations and details of edge conditions, joints, expansion joints, standing seam profiles, anchorages, blocking, flashings, closures, tie-ins to adjacent construction, and all other details required to fully illustrate all conditions of work. Distinguish between factory and field assembly work.
 - 1. Shop Drawings shall bear the seal and signature of a Professional Engineer, licensed in the State of Maine.
 - 2. Layout drawings and sections shall show adjacent construction, and be keyed into benchmarks and grid lines established on the Contract Drawings.
 - 3. Details shall show dimensions, thicknesses, materials, finishes, continuous anchors, edge trim, sealant locations, fasteners and spacing, etc. Details shall also show and identify joint conditions, anticipated fabrication and erection tolerances, anticipated thermal movement, etc.
 - 4. Provide isometric drawings for each juncture between flashing assemblies, at interfacing and adjacent work, at penetrations, and at typical roof transitions and end conditions.
 - 5. Roofing panel, waterproofing membrane, vapor retarder, edge trim, etc., joints shall be laid out on the Shop Drawings. It shall be understood that the Engineer will be at liberty to revise joint layouts as deemed necessary, at no additional cost and with no time extension.

6. Submit erection drawings showing proposed sequence of installation.
 7. Submit manufacturer's written instructions and comments, fastener descriptions and spacings, and all other pertinent information.
 8. Submit manufacturer's written instructions and details for the snow guard system.
- B. Product Data: Submit specifications for material and fabrication of metal roofing system materials, and detailed instructions and recommendations for handling, storing, installation and maintenance. Include manufacturers' product data for roof panels, fasteners, sealants, backer rod, insulation, vapor retarder, waterproofing membrane, and all other manufactured products. Include certified test reports showing compliance with requirements where a test method is indicated.
- C. Samples
1. Submit samples of roofing system components. Provide assembled sample panels 18 inches long by two panels wide using the same materials to be used in the finished work. Include continuous anchors, fasteners, waterproofing membrane, insulation and other accessories. Provide a horizontal (end) joint on each side of standing seam in the middle of the sample panel.
 2. Submit a 24 inch long radius roof edge fabrication (e.g., edge cover and brake metal closures), each with typical finished mating joints.
- D. Quality Control/Assurance Submittals
1. Submit for review copies of ASCE-7 Load Analysis prepared and/or reviewed and sealed by a Professional Engineer licensed in the State of Maine.
 2. Submit design calculations bearing the seal and signature of a Professional Engineer licensed in the State of Maine, indicating compliance with specified performance criteria and fastener pull-out calculations. The submittal shall indicate fastener types, spacings and numbers required for each installation condition.
 3. Submit test reports for independent testing laboratories bearing the seal of a registered Professional Engineer to certify compliance with the specified performance criteria.
 4. Submit complete and current data for the roof system as follows:
 - a. Thermal cycle testing of the metal roof panel and continuous panel anchors as specified.

- b. Uniform ultimate wind uplift load capacity for the roofing system specified.
 - c. Ultimate pullout capacity for all anchors.
 - d. U.L. 90 classification data specific to the roofing system to be provided. Include letter by U.L. attesting that the roofing system is currently classified and listed.
 - e. Model load test per ASTM E 330, modified.
 - f. Static air infiltration test data.
 - g. Water penetration test data.
5. Submit manufacturer's complete log of field reports (initial, progress and final).
 6. Upon completion of the work, submit letter from the manufacturer certifying that the roof installations are in accordance with the approved Shop Drawings and installation instructions and requirements, and that the manufacturer will issue the specified watertightness warranty.

E. Welding

Submit welder certifications.

F. Warranties

Submit samples of the roofing manufacturer's twenty-year warranty agreeing to repair/replace defective materials and workmanship in an aesthetically acceptable manner, to the Authority's complete satisfaction, as required to maintain the roofing installations, including flashings, trim, etc., in a watertight condition under peak weather conditions. Warranty shall not exclude any conditions, such as flashings, trim, penetrations, etc.

Submit sample of the roofing manufacturer's standard twenty-year sheet steel warranty and material finish warranty.

Warranties shall be in addition to and not a limitation of other rights the Authority may have against the Contractor under the Contract Documents.

1.4 QUALITY ASSURANCE

- A. Contractor shall have a minimum of 5 years continuous successful experience in fabricating and installing roofing systems of similar type (e.g., long field-formed panels) and complexity to that required for this Project and shall be an authorized installer for the roofing system manufacturer. Submit a list of installations. The manufacturer of the roofing system shall have a minimum of 10-years experience in the manufacturer of roofing systems of the type required for this Project.

- B. Use adequate numbers of skilled workmen who are thoroughly trained and experienced in the necessary crafts, and who are completely familiar with the specified requirements and the methods needed for proper performance of the work of this Section.
- C. Manufacturer's representative is to inspect and approve surfaces to which the roofing system material will be applied prior to start of work and shall instruct and assist installer as deemed necessary. Manufacturer's representative shall also provide intermittent project supervision and final inspection at end of work and before issuance of warranty. Also refer to paragraph 3.03.
- D. In addition to complying with requirements of governmental agencies having jurisdiction, the roofing system shall comply with U.L. Class 90 wind uplift requirements based on wind loads at the site, U.L. Class A fire rating requirements and pertinent recommendations contained in the SMACNA "Architectural Sheet Metal Manual".
- E. Roof System Requirements
 - 1. Structural Tests: Installed roof system shall carry positive uniform design loads with maximum system deflection of $L/180$ as measured at the rib of the panel.
 - 2. Water Penetration: Installed roof system shall exhibit no uncontrolled water penetration when exposed to dynamic rain at 6.25 psf differential air pressure for not less than five minutes, when testing in accordance with ASTM E 331.
 - 3. The metal roof system shall be designed to:
 - a. Drain leakage and condensation to the exterior.
 - b. Provide independent movement of all roof components consistent with a thermal range of -20 to +180 degrees F, and consistent with anticipated movement of the building structures.
 - c. Provide panel weathertightness without reliance on sealants or elastomeric membranes.
 - d. Provide flashing, gutters, downspouts and edge assemblies related to the roof that are watertight.
 - e. Provide required wind uplift resistance as determined by ASCE-7 analysis with a safety factor of 1.5.

F. Panel Anchor Requirements

Connection of continuous panel anchors to substrate shall be designed to resist loads developed by the specified pressures with due regard to prying forces and/or bending due to eccentric loading. Performances shall be evaluated at positions of extreme thermal movement. Factor of safety for connections shall be 2.5.

- G. Uniform load capacity of 2 times design load shall be determined by testing in accordance with the principles of ASTM E 330, adapted to testing of formed sheet panels by additions to specific sections as follows:
1. Roof test specimens shall represent the conditions evaluated, free of undue influence of perimeter conditions. Panels shall be continuous over one or more interior supports and contain at least four panel widths.
 2. No roof attachments are permitted at the sides other than the standard edge condition. For uplift tests, at least one end seal shall be flexible and in no way restrain the crosswise distortion of the panels.
 3. Roofing panels and accessories are to be production material of the same type and thickness required for use on the Project.
 4. Longitudinal seals or plastic film shall not span any crevice or crack that may tend to separate under differential pressure.
- H. Any necessary welding shall be performed only by skilled workmen with current AWS certification for the type of welding work required for this Contract. Welding shall be performed in accordance with applicable AWS requirements.

PART 2 - PRODUCTS

2.1 GENERAL

- A. Fabricate for waterproof and weather-resistant performance, with expansion provisions for running work, sufficient to permanently prevent leakage, damage, and deterioration of the work. Form work to fit substrates. Comply with roofing system manufacturer's instructions and recommendations for forming material.
- B. Materials shall be selected for their surface flatness and freedom from blemishes. Materials exhibiting waves, roller marks, gouges, dents, creases, pitting, scrapes, scars and similar defects will be rejected.
- C. All metal work shall be formed to produce installed units free from waves, buckling, severe oil-canning and similar defects under all conditions of service. Units shall be formed true to line, with smooth "sharp" bend lines, and with exposed edges folded back to form hems.

2.2 ROOF SYSTEM MANUFACTURERS

- A. The "Zee-Lock Roof System" produced by Berridge Manufacturing Company (as indicated in current literature) is cited as capable of meeting the appearance, quality, construction type, performance and durability requirements of this Contract. Systems by other manufacturers that are equivalent in all respects (i.e., appearance, type of construction, performance and durability), may be used in the work. However, it shall be

understood that the Resident will be the sole judge of a system's acceptability, and that the rejection of a proposed system shall not give rise to any claims for additional compensation or extension to the Time(s) of Completion.

2.3 METAL ROOF PANELS

- A. Minimum 24 gage aluminum-zinc alloy (Galvalume) coated sheet steel conforming to ASTM A 792 in continuous field formed panels of the required lengths. The gage of the coated steel shall be increased from 24 gage, at no additional cost, if necessary to meet Contract requirements.
- B. Panels shall have a minimum 2 inch vertical rib height, spaced 16 inches on center.
- C. Panels shall be true standing seam shape, requiring no foam closures or fillers at terminations.
- D. Standing seams shall incorporate mechanically interlocked continuous anchors of a configuration that will prevent entrance or passage of water.
- E. Continuous concealed anchors shall resist positive and negative loading yet permit thermal expansion and contraction of panels.
- F. Seams that are not mechanically locked are not acceptable.
- G. Standing seams shall contain a factory applied extruded vinyl weather seal to prevent siphoning of moisture through the side joint seam.
- H. Horizontal seams shall not be permitted.

2.4 CONTINUOUS ANCHORS

- A. Standing seam roof panels shall be fastened to continuous zee-shaped anchors that are secured to the substrate.
- B. Manufacturer shall design the continuous anchors, fasteners and fastener spacing to maintain the required wind uplift resistance and other performance criteria.

2.5 MISCELLANEOUS METAL

- A. Provide all necessary terminations, flashings, gutters, edge conditions, special shapes, transitions, expansion joints, etc., required for complete and weathertight installations. All such items shall be the same material as the roof panels, except that edge condition materials and brake metal closures shall be minimum 22 gage.

B. Fasteners

Exposed fasteners shall be Series 300 stainless steel fasteners with neoprene-backed watertight stainless steel washers. All exposed portions of fasteners and washers shall receive a two-coat high quality urethane finish to match the roof panels.

Exposed rivets, where approved by the Engineer, shall be self-plugging type, minimum 3/16 inch diameter, fabricated from Series 300 stainless steel with the same material for stems, and with neoprene seal washers.

Concealed fasteners shall be corrosion resistant type equal to self-drilling "Dril-lex" fasteners with "Stalgard" coating by Elco Industries, Inc., Rockford, IL.

Fasteners and plates for installation of insulation shall be equal to "Sarnafasteners and Plates" by Sarnafil, Inc., Canton, MA.

C. Plywood Sheathing

As specified in Rough Carpentry Section.

D. Roofing Underlayment

Shall be ice/waterproofing membrane specified below.

E. Ice/Waterproofing Membrane

Self-adhering 60 mil reinforced rubberized asphalt waterproofing membrane equal to "Winter Guard Waterproofing Shingle Underlayment" by CertainTeed Corporation, Valley Forge, PA.

F. Vapor Retarder

Shall be the ice/waterproofing membrane specified above.

G. Sealant

One-part silicone sealant equal to "Spectrem 1" by Tremco Sealants and Coatings, Beachwood, OH.

H. Fall Protection Roof Anchors: Provide fall protection roof anchors in locations indicated in the drawings. Provide Guardian CB-12 Roof Anchor or similar as approved by the Engineer.

2.6 FABRICATION

A. Fabricate panels onsite in continuous lengths as required. Examine panels as they are being formed to insure that they are within the manufacturer's acceptable tolerances.

- B. Provide linear sheet metal items in minimum 10'-0" lengths except as otherwise approved on the Shop Drawings. Form flashing using single pieces for the full width. Provide shop fabricated, mitered and joint corners.
- C. Comply with the dimensions, profiles, and details shown, or if not shown, in accordance with details provided by the Engineer.

2.7 SNOW GUARDS

- A. Snow guards shall be prefabricated ladder type, aluminum two-pipe snow guards designed for use with standing seam metal roofing and complete with brackets and fasteners for anchoring as manufactured by Alpine Snow guards. Acceptable alternate bracket manufacturer shall be S-5! Metal Roof Innovations, Ltd. All snow guard components, including brackets and fasteners, shall match the color of the standing seam roof panels as selected by the Architect. No exceptions will be allowed.

2.8 GUTTERS AND DOWNSPOUTS

- A. Gutters and downspouts shall be fabricated in sizes indicated. Gutters shall be seamless. Downspouts shall have sealed joints at bends, continuous seamless lengths at straight sections. Splashblocks shall be preformed cast concrete.

PART 3 - EXECUTION

3.1 INSTALLATION

- A. Inspection: Examine substrates to receive roofing. Do not proceed until all defects are corrected.

Verify that decks are sound, dry, and securely attached, and that provisions for flashings, expansion joints, and all items attaching or penetrating through the work of this Section have been provided for and that roofing work may proceed.

Field check dimensions and support alignment.

Provide all fastener alignment markings necessary so that marks can be transferred onto vapor retarder, as appropriate.

- B. Sheathing: Installed as specified - Rough Carpentry Section.
- C. Ice/Waterproofing Membrane: After the sheathing installation has been approved by the roofing system manufacturer's representative, apply ice/waterproofing membrane over sheathing in accordance with the approved Shop Drawings and the membrane manufacturer's installation instructions, taking care to provide 6 inch weatherlapped head joints and 18 inch lapped end joints in a manner to drain any entrapped moisture to the exterior.

D. Installation of Metal Roofing and Flashing

1. Install roofing in strict accordance with the approved Shop Drawings and installation instructions.
2. Metal workmanship shall conform to applicable standards set forth in the "Architectural Sheet Metal Manual" as published by SMACNA.
3. Isolate dissimilar metals and masonry or concrete from metals with an Engineer approved bituminous coating. Use gasketed fasteners where required to prevent corrosive action between fastener, substrate and panels.
4. Limit exposed fasteners to extent indicated on Shop Drawings.
5. Anchorage shall allow for temperature expansion and contraction movement without stress or elongation of panels or fasteners. Attach continuous panel anchor to structural substrate using fasteners of size and spacing as determined by manufacturer's design analysis to resist specified uplift and thermal movement forces.
6. Coordinate flashing and sheet metal work to provide weathertight conditions at roof terminations. Fabricate and install in accordance with standards of SMACNA Manual using continuous cleats at all exposed edges.
7. Roofing, fascia overlay, gutter and accessories shall be installed in accordance with the approved Shop Drawings and installation instructions such that in plan and elevation, horizontal and vertical lines are true and square, and that other lines are as shown on the approved Shop Drawings. Provide adjustment within system to accommodate variations of existing structure. Deviation from designated locations shall not exceed 1/8 inch per 12 feet of length of any member or 1/4 inch in any total run in any line.
8. Verify with manufacturer locations of fixed connections and expansion connections.
9. Roll form panels on site taking care to properly support long panels (support at maximum 6 foot intervals).
10. Install starter and edge trim and fascia overlay before installing roof panels.
11. Install panels to continuous anchors (ribs) in accordance with the manufacturer's details.
12. Seam panel sidelaps using power-driven seamer as recommended by manufacturer to ensure watertightness.
13. Erect metal roofing with lines, planes, arrises and angles sharp and true, and plane surfaces free from waves, warp, dents, buckles, or other physical defects, with minimum oil canning.

14. Do not allow traffic on completed roof. If required, provided cushioned walk boards.
15. Protect installed roof panels and trim from damage caused by adjacent construction until completion of installation.
16. Remove and replace any panels or components which are damaged beyond successful repair.
17. Fit components accurately together to form joints that will be weathertight.
18. Do not install components which are observed to be defective, including, but not limited to those that are warped, bowed, twisted, dented, abraded, or otherwise damaged, including damage to finish.
19. Do not cut, trim, weld, or braze component parts during erection in a manner which would damage the finish, decrease strength, or result in a visual imperfection or a failure in performance.
20. Do not allow panels to come into contact with dissimilar materials. Apply an Engineer approved isolator between surfaces. Use gasketed fasteners to eliminate the possibility of corrosive or electrolytic action between metals.
21. Coordinate the roofing work with that of other trades as necessary.
22. Thoroughly wipe-down roofing and other surfaces as erection progresses.
23. Install sealant as shown on the approved Shop Drawings and installation instructions.

F. Flashing

1. Comply with "SMACNA" Architectural Sheet Metal Manual" recommendations for installation of work.
2. Conceal fasteners and expansion provisions wherever possible.
3. Fold back edges of concealed side of exposed edge to form hem.
4. Insert metal flashings into reglets, anchor with fasteners and wedges and seal joints.
5. Set sheet metal items level, true to line, and plumb.
6. Secure to wood with screws.
7. Set metal already partly formed in place and fasten by means of cleats.

8. Use cleats to keep laps closed when face width exceeds 8 inches for 24 gauge steel.
- G. Damaged Finishes: Repair damaged finish of panels, trim, closures, flashing, etc., to the satisfaction of the Engineer. If any item cannot be repaired to the Engineer's satisfaction, it shall be promptly replaced.
- H. Snow Guards: Install as indicated on the Plans and as recommended by the manufacturer.
- I. Fall Protection Roof Anchors: Install in accordance with the roof anchor manufacturer's written instructions and in accordance with the metal roofing manufacturer.
- H. Gutters and Downspouts: Install in lengths and locations indicated using straps and hangers matching material and finish of gutters and downspouts. Install splashblocks at grade below downspout outlet. Downspout outlet shall be 6" above splashblock.

3.3 FIELD QUALITY CONTROL

- A. Manufacturer's Field Service:
 1. Manufacturer's representative shall be present at each pre-installation and pre-roofing conference, and during set-up of manufacturer's field forming equipment.
 2. Manufacturer's representative shall examine the roof structures with installer prior to beginning roof installation.
 3. Manufacturer's representative shall be present during initial layout and installation of roofing system. Observe minimum of initial one week period of roof panel installation on daily basis, ensuring installer follows manufacturer's installation recommendations and shop drawings. Observe initial forming passes for fabrication with acceptable tolerances.
 4. Manufacturer's representative shall be on site for the duration of the installation period.
 5. Manufacturer's representative shall examine completed installation for conformance to Shop Drawings. Notify installer and Contractor in writing of discrepancies.

3.4 CLEANING

- A. Clean exposed surfaces of work promptly after completion of installation. To prevent rust staining on finished surfaces, immediately removing fillings produced by drilling or cutting.
- B. Clean roof in accordance with manufacturer's recommendations.
- C. Clean exposed surfaces of roofing and accessories after completion of installation. Leave in clean condition at date of Substantial Completion of Project. Touch up minor abrasions and scratches in finish.

- D. Remove all scrap and construction debris from the site.

3.5 FINAL INSPECTION

- A. Final inspection and certification will be provided by the manufacturer's representative.

3.6 PROTECTION AND CLEAN-UP

- A. Leave all work clean, free from grease, finger marks, sealant stains, etc. Remove excess sealant, dirt and other substances from roofing system components and from abutting and surrounding construction. Cleaning materials and procedures shall be approved by the Engineer and be acceptable to the manufacturers of the materials to be cleaned. Advise the Contractor of protective measures and precautions required to ensure that roofing installations will be without damage or deterioration (other than normal weathering) at time of acceptance.
- B. Remove all debris and rubbish caused by the work of this Section as the work progresses.

END OF SECTION

SECTION 07720

ROOF HATCHES (TUNNEL ACCESS HATCH)

PART 1 – GENERAL

1.1 SUMMARY

- A. Work Included: Provide factory-fabricated roof hatch for tunnel access.

1.2 SUBMITTALS

- A. Product Data: Submit manufacturer's product data.
- B. Shop Drawings: Submit shop drawings including profiles, accessories, location, adjacent construction interface, and dimensions.
- C. Warranty: Submit executed copy of manufacturer's standard warranty.

1.3 QUALITY ASSURANCE

- A. Manufacturer: A minimum of 5 years' experience manufacturing similar products.
- B. Installer: A minimum of 2 years' experience installing similar products.
- C. Manufacturer's Quality System: Registered to ISO 9001:2008 Quality Standards including in-house engineering for product design activities.

1.4 DELIVERY, STORAGE AND HANDLING

- A. Deliver products in manufacturer's original packaging. Store materials in a dry, protected, well-vented area. Inspect product upon receipt and report damaged material immediately to delivering carrier and note such damage on the carrier's freight bill of lading.

1.5 WARRANTY

- A. Manufacturer's Warranty: Provide manufacturer's standard warranty. Materials shall be free of defects in material and workmanship for a period of five years from the date of purchase. Should a part fail to function in normal use within this period, manufacturer shall furnish a new part at no charge.

PART 2 - PRODUCTS

2.1 MANUFACTURER

- A. Basis-of-Design Manufacturer: Type D Roof Hatch by The Bilco Company, P.O. Box 1203, New Haven, CT 06505, 1-800-366-6530, Fax: 1-203-933-8478, Web: www.bilco.com.

2.2 ROOF HATCH

- A. Furnish and install where indicated on plans metal roof hatch Type D, size 4'-0" width x 6'-0" length. Length denotes hinge side. The roof hatch shall be double leaf. The roof hatch shall be pre-assembled from the manufacturer.
- B. Performance characteristics:
1. Covers shall be reinforced to support a minimum live load of 50 psf with a maximum deflection of 1/150th of the span or 20 psf wind uplift.
 2. Operation of the covers shall be smooth and easy with controlled operation throughout the entire arc of opening and closing.
 3. Operation of the covers shall not be affected by temperature.
 4. Entire hatch shall be weather tight with fully welded corner joints on covers and curb
- C. Covers: Shall be 14 gauge (1.9 mm) paint bond G-90 galvanized steel or 11 gauge (2.3mm) aluminum with a 3" (76mm) beaded flange with formed reinforcing members. Covers shall have a heavy extruded EPDM rubber gasket that is bonded to the cover interior to assure a continuous seal when compressed to the top surface of the curb.
- D. Cover insulation: Shall be fiberglass of 1" (25mm) thickness, fully covered and protected by a metal liner 22 gauge (.8mm) paint bond G-90 galvanized steel or 18 gauge (1mm) aluminum.
- E. Curb: Shall be 12" (305mm) in height and of 14 gauge paint (1.9 mm) bond G-90 galvanized steel or 11 gauge (2.3mm) aluminum. The curb shall be formed with a 3-1/2" (89mm) flange with 7/16" (11mm) holes provided for securing to the tunnel chimney.
- F. Curb insulation: Shall be rigid, high-density fiberboard of 1" (25mm) thickness on outside of curb.
- G. Lifting mechanisms: Manufacturer shall provide compression spring operators enclosed in telescopic tubes to provide, smooth, easy, and controlled cover operation throughout the entire arc of opening and closing. The upper tube shall be the outer tube to prevent accumulation of moisture, grit, and debris inside the lower tube assembly. The lower tube shall interlock with a flanged support shoe [for aluminum construction: welded to the curb assembly; for steel construction: through bolted to the curb assembly].

H. Hardware

1. Heavy pintle hinges shall be provided.
2. Covers shall be equipped with an enclosed two point spring latch with interior and exterior turn handles.
3. Roof hatch shall be equipped with interior and exterior padlock hasps.
4. The latch strike shall be a stamped component bolted to the curb assembly.
5. Covers shall automatically lock in the open position with a rigid hold open arm equipped with a 1" (25mm) diameter red vinyl grip handle to permit easy release for closing.
6. Compression spring tubes shall be an anti-corrosive composite material and all other hardware shall be zinc plated and chromate sealed.
7. Cover hardware shall be bolted into heavy gauge channel reinforcing welded to the underside of the cover and concealed within the insulation space.

- I. Finishes: Factory finish shall be alkyd based red oxide primed steel or mill finish aluminum.

PART 3 - EXECUTION

3.1 EXAMINATION

- A. Examine substrates and openings for compliance with requirements for installation tolerances and other conditions affecting performance. Proceed with installation only after unsatisfactory conditions have been corrected.

3.2 INSTALLATION

- A. Install products in strict accordance with manufacturer's instructions and approved submittals. Locate units level, plumb, and in proper alignment with adjacent work.
1. Test units for proper function and adjust until proper operation is achieved.
 2. Repair finishes damaged during installation.
 3. Restore finishes so no evidence remains of corrective work.

3.3 ADJUSTING AND CLEANING

- A. Clean exposed surfaces using methods acceptable to the manufacturer which will not damage finish.

END OF SECTION

SECTION 07841

PENETRATION FIRESTOPPING

PART 1 - GENERAL

1.1 RELATED DOCUMENTS

- A. Drawings and general provisions of the Contract, including General and Supplementary Conditions and Division 01 Specification Sections, apply to this Section.

1.2 SUMMARY

- A. Section Includes:
 - 1. Penetrations in fire-resistance-rated walls.
 - 2. Penetrations in horizontal assemblies.
 - 3. Penetrations in smoke barriers.

1.3 PREINSTALLATION MEETINGS

- A. Preinstallation Conference: Conduct conference at Project site.

1.4 ACTION SUBMITTALS

- A. Product Data: For each type of product.
- B. Product Schedule: For each penetration firestopping system. Include location, illustration of firestopping system, and design designation of qualified testing and inspecting agency.
 - 1. Engineering Judgments: Where Project conditions require modification to a qualified testing and inspecting agency's illustration for a particular penetration firestopping system, submit illustration, with modifications marked, approved by penetration firestopping system manufacturer's fire-protection engineer as an engineering judgment or equivalent fire-resistance-rated assembly. Obtain approval of authorities having jurisdiction prior to submittal.

1.5 INFORMATIONAL SUBMITTALS

- A. Qualification Data: For Installer.
- B. Product Test Reports: For each penetration firestopping system, for tests performed by a qualified testing agency.

1.6 CLOSEOUT SUBMITTALS

- A. Installer Certificates: From Installer indicating that penetration firestopping systems have been installed in compliance with requirements and manufacturer's written instructions.

1.7 QUALITY ASSURANCE

- A. Installer Qualifications: A firm that has been approved by FM Global according to FM Global 4991, "Approval of Firestop Contractors," or been evaluated by UL and found to comply with its "Qualified Firestop Contractor Program Requirements."

1.8 PROJECT CONDITIONS

- A. Environmental Limitations: Do not install penetration firestopping system when ambient or substrate temperatures are outside limits permitted by penetration firestopping system manufacturers or when substrates are wet because of rain, frost, condensation, or other causes.
- B. Install and cure penetration firestopping materials per manufacturer's written instructions using natural means of ventilations or, where this is inadequate, forced-air circulation.

1.9 COORDINATION

- A. Coordinate construction of openings and penetrating items to ensure that penetration firestopping systems can be installed according to specified firestopping system design.
- B. Coordinate sizing of sleeves, openings, core-drilled holes, or cut openings to accommodate penetration firestopping systems.

PART 2 - PRODUCTS

2.1 PERFORMANCE REQUIREMENTS

- A. Fire-Test-Response Characteristics:
 - 1. Perform penetration firestopping system tests by a qualified testing agency acceptable to authorities having jurisdiction.
 - 2. Test per testing standards referenced in "Penetration Firestopping Systems" Article. Provide rated systems complying with the following requirements:
 - a. Penetration firestopping systems shall bear classification marking of a qualified testing agency.
 - 1) UL in its "Fire Resistance Directory."
 - 2) Intertek Group in its "Directory of Listed Building Products."
 - 3) FM Global in its "Building Materials Approval Guide."

2.2 PENETRATION FIRESTOPPING SYSTEMS

- A. Penetration Firestopping Systems: Systems that resist spread of fire, passage of smoke and other gases, and maintain original fire-resistance rating of construction penetrated. Penetration firestopping systems shall be compatible with one another, with the substrates forming openings, and with penetrating items if any.
- B. Penetrations in Fire-Resistance-Rated Walls: Penetration firestopping systems with ratings determined per ASTM E 814 or UL 1479, based on testing at a positive pressure differential of 0.01-inch wg.
 - 1. F-Rating: Not less than the fire-resistance rating of constructions penetrated.
- C. Penetrations in Horizontal Assemblies: Penetration firestopping systems with ratings determined per ASTM E 814 or UL 1479, based on testing at a positive pressure differential of 0.01-inch wg.
 - 1. F-Rating: At least one hour, but not less than the fire-resistance rating of constructions penetrated.
 - 2. T-Rating: At least one hour, but not less than the fire-resistance rating of constructions penetrated except for floor penetrations within the cavity of a wall.
 - 3. W-Rating: Provide penetration firestopping systems showing no evidence of water leakage when tested according to UL 1479.
- D. Penetrations in Smoke Barriers: Penetration firestopping systems with ratings determined per UL 1479, based on testing at a positive pressure differential of 0.30-inch wg.
 - 1. L-Rating: Not exceeding 5.0 cfm/sq. ft. of penetration opening at and no more than 50-cfm cumulative total for any 100 sq. ft. at both ambient and elevated temperatures.
- E. Exposed Penetration Firestopping Systems: Flame-spread and smoke-developed indexes of less than 25 and 450, respectively, per ASTM E 84.
- F. VOC Content: Penetration firestopping sealants and sealant primers shall comply with the following limits for VOC content:
 - 1. Sealants: 250 g/L.
 - 2. Sealant Primers for Nonporous Substrates: 250 g/L.
 - 3. Sealant Primers for Porous Substrates: 775 g/L.
- G. Low-Emitting Materials: Penetration firestopping sealants and sealant primers shall comply with the testing and product requirements of the California Department of Public Health's "Standard Method for the Testing and Evaluation of Volatile Organic Chemical Emissions from Indoor Sources Using Environmental Chambers."
- H. Accessories: Provide components for each penetration firestopping system that are needed to install fill materials and to maintain ratings required. Use only those components specified by penetration firestopping system manufacturer and approved by qualified testing and inspecting agency for conditions indicated.

1. Permanent forming/damming/backing materials.
2. Substrate primers.
3. Collars.
4. Steel sleeves.

2.3 FILL MATERIALS

- A. Cast-in-Place Firestop Devices: Factory-assembled devices for use in cast-in-place concrete floors and consisting of an outer sleeve lined with an intumescent strip, a flange attached to one end of the sleeve for fastening to concrete formwork, and a neoprene gasket.
- B. Latex Sealants: Single-component latex formulations that do not re-emulsify after cure during exposure to moisture.
- C. Firestop Devices: Factory-assembled collars formed from galvanized steel and lined with intumescent material sized to fit specific diameter of penetrant.
- D. Intumescent Composite Sheets: Rigid panels consisting of aluminum-foil-faced intumescent elastomeric sheet bonded to galvanized-steel sheet.
- E. Intumescent Putties: Nonhardening, water-resistant, intumescent putties containing no solvents or inorganic fibers.
- F. Intumescent Wrap Strips: Single-component intumescent elastomeric sheets with aluminum foil on one side.
- G. Mortars: Prepackaged dry mixes consisting of a blend of inorganic binders, hydraulic cement, fillers and lightweight aggregate formulated for mixing with water at Project site to form a nonshrinking, homogeneous mortar.
- H. Pillows/Bags: Reusable heat-expanding pillows/bags consisting of glass-fiber cloth cases filled with a combination of mineral-fiber, water-insoluble expansion agents, and fire-retardant additives. Where exposed, cover openings with steel-reinforcing wire mesh to protect pillows/bags from being easily removed.
- I. Silicone Foams: Multicomponent, silicone-based liquid elastomers that, when mixed, expand and cure in place to produce a flexible, nonshrinking foam.
- J. Silicone Sealants: Single-component, silicone-based, neutral-curing elastomeric sealants.

2.4 MIXING

- A. Penetration Firestopping Materials: For those products requiring mixing before application, comply with penetration firestopping system manufacturer's written instructions for accurate proportioning of materials, water (if required), type of mixing equipment, selection of mixer speeds, mixing containers, mixing time, and other items or procedures needed to produce products of uniform quality with optimum performance characteristics for application indicated.

PART 3 - EXECUTION

3.1 EXAMINATION

- A. Examine substrates and conditions, with Installer present, for compliance with requirements for opening configurations, penetrating items, substrates, and other conditions affecting performance of the Work.
- B. Proceed with installation only after unsatisfactory conditions have been corrected.

3.2 PREPARATION

- A. Surface Cleaning: Before installing penetration firestopping systems, clean out openings immediately to comply with manufacturer's written instructions and with the following requirements:
 - 1. Remove from surfaces of opening substrates and from penetrating items foreign materials that could interfere with adhesion of penetration firestopping materials.
 - 2. Clean opening substrates and penetrating items to produce clean, sound surfaces capable of developing optimum bond with penetration firestopping materials. Remove loose particles remaining from cleaning operation.
 - 3. Remove laitance and form-release agents from concrete.
- B. Prime substrates where recommended in writing by manufacturer using that manufacturer's recommended products and methods. Confine primers to areas of bond; do not allow spillage and migration onto exposed surfaces.

3.3 INSTALLATION

- A. General: Install penetration firestopping systems to comply with manufacturer's written installation instructions and published drawings for products and applications.
- B. Install forming materials and other accessories of types required to support fill materials during their application and in the position needed to produce cross-sectional shapes and depths required to achieve fire ratings.
 - 1. After installing fill materials and allowing them to fully cure, remove combustible forming materials and other accessories not forming permanent components of firestopping.
- C. Install fill materials by proven techniques to produce the following results:
 - 1. Fill voids and cavities formed by openings, forming materials, accessories and penetrating items to achieve required fire-resistance ratings.
 - 2. Apply materials so they contact and adhere to substrates formed by openings and penetrating items.
 - 3. For fill materials that will remain exposed after completing the Work, finish to produce smooth, uniform surfaces that are flush with adjoining finishes.

3.4 IDENTIFICATION

- A. Wall Identification: Permanently label walls containing penetration firestopping systems with the words "FIRE AND/OR SMOKE BARRIER - PROTECT ALL OPENINGS," using lettering not less than 3 inches high and with minimum 0.375-inch strokes.
 - 1. Locate in accessible concealed floor, floor-ceiling, or attic space at 15 feet from end of wall and at intervals not exceeding 30 feet.
- B. Penetration Identification: Identify each penetration firestopping system with legible metal or plastic labels. Attach labels permanently to surfaces adjacent to and within 6 inches of penetration firestopping system edge so labels are visible to anyone seeking to remove penetrating items or firestopping systems. Use mechanical fasteners or self-adhering-type labels with adhesives capable of permanently bonding labels to surfaces on which labels are placed. Include the following information on labels:
 - 1. The words "Warning - Penetration Firestopping - Do Not Disturb. Notify Building Management of Any Damage."
 - 2. Contractor's name, address, and phone number.
 - 3. Designation of applicable testing and inspecting agency.
 - 4. Date of installation.
 - 5. Manufacturer's name.
 - 6. Installer's name.

3.5 FIELD QUALITY CONTROL

- A. Owner will engage a qualified testing agency to perform tests and inspections according to ASTM E 2174.
- B. Where deficiencies are found or penetration firestopping system is damaged or removed because of testing, repair or replace penetration firestopping system to comply with requirements.
- C. Proceed with enclosing penetration firestopping systems with other construction only after inspection reports are issued and installations comply with requirements.

3.6 CLEANING AND PROTECTION

- A. Clean off excess fill materials adjacent to openings as the Work progresses by methods and with cleaning materials that are approved in writing by penetration firestopping system manufacturers and that do not damage materials in which openings occur.
- B. Provide final protection and maintain conditions during and after installation that ensure that penetration firestopping systems are without damage or deterioration at time of Substantial Completion. If, despite such protection, damage or deterioration occurs, immediately cut out and remove damaged or deteriorated penetration firestopping material and install new materials to produce systems complying with specified requirements.

3.7 PENETRATION FIRESTOPPING SYSTEM SCHEDULE

- A. Where UL-classified systems are indicated, they refer to system numbers in UL's "Fire Resistance Directory" under product Category XHEZ.
- B. Where FM Global-approved systems are indicated, they refer to design numbers listed in FM Global's "Building Materials Approval Guide" under "Wall and Floor Penetration Fire Stops."
- C. Penetration Firestopping Systems with No Penetrating Items: UL Classified System Group 0001-1000.
 - 1. F-Rating: 1 & 2 hour.
 - 2. T-Rating: 1 & 2 hour.
 - 3. W-Rating: No leakage of water at completion of water leakage testing.
 - 4. Type of Fill Materials: As required to achieve rating.
- D. Penetration Firestopping Systems for Metallic Pipes, Conduit, or Tubing: UL Classified System Group 1001-1999.
 - 1. F-Rating: 1 & 2 hour.
 - 2. T-Rating: 1 & 2 hour.
 - 3. W-Rating: No leakage of water at completion of water leakage testing.
 - 4. Type of Fill Materials: As required to achieve rating.
- E. Penetration Firestopping Systems for Nonmetallic Pipe, Conduit, or Tubing: UL Classified System Group 2001-2999.
 - 1. F-Rating: 1 & 2 hour.
 - 2. T-Rating: 1 & 2 hour.
 - 3. W-Rating: No leakage of water at completion of water leakage testing.
 - 4. Type of Fill Materials: As required to achieve rating.
- F. Penetration Firestopping Systems for Electrical Cables: UL Classified System Group 3001-3999.
 - 1. F-Rating: 1 & 2 hour.
 - 2. T-Rating: 1 & 2 hour.
 - 3. W-Rating: No leakage of water at completion of water leakage testing.
 - 4. Type of Fill Materials: As required to achieve rating.
- G. Penetration Firestopping Systems for Cable Trays with Electric Cables: UL Classified System Group 4001-4999.
 - 1. F-Rating: 1 & 2 hour.
 - 2. T-Rating: 1 & 2 hour.
 - 3. W-Rating: No leakage of water at completion of water leakage testing.
 - 4. Type of Fill Materials: As required to achieve rating.
- H. Penetration Firestopping Systems for Insulated Pipes: UL Classified System Group 5001-5999.
 - 1. F-Rating: 1 & 2 hour.
 - 2. T-Rating: 1 & 2 hour.
 - 3. W-Rating: No leakage of water at completion of water leakage testing.
 - 4. Type of Fill Materials: As required to achieve rating.

- I. Penetration Firestopping Systems for Miscellaneous Electrical Penetrants: UL Classified System Group 6001-6999.
 - 1. F-Rating: 1 & 2 hour.
 - 2. T-Rating: 1 & 2 hour.
 - 3. W-Rating: No leakage of water at completion of water leakage testing.
 - 4. Type of Fill Materials: As required to achieve rating.

- J. Penetration Firestopping Systems for Miscellaneous Mechanical Penetrants: UL Classified System Group 7001-7999.
 - 1. F-Rating: 1 & 2 hour.
 - 2. T-Rating: 1 & 2 hour.
 - 3. W-Rating: No leakage of water at completion of water leakage testing.
 - 4. Type of Fill Materials: As required to achieve rating.

- K. Penetration Firestopping Systems for Groupings of Penetrants: UL Classified System Group 8001-8999.
 - 1. F-Rating: 1 & 2 hour.
 - 2. T-Rating: 1 & 2 hour.
 - 3. W-Rating: No leakage of water at completion of water leakage testing.
 - 4. Type of Fill Materials: As required to achieve rating.

END OF SECTION

SECTION 07900

JOINT SEALERS

PART 1 - GENERAL

1.1 RELATED DOCUMENTS

- A. Examine Drawings, Contract Conditions all other Sections of the Specifications for requirements which affect work of this Section whether or not such work is specifically mentioned in this Section.
- B. Coordinate work with that of all other trades affecting, or affected by work of this Section. Cooperate with such trades to assure the steady progress of all Project work.

1.2 DESCRIPTION

- A. In general, the conditions requiring joint sealers are shown on the Drawings. This phase of work includes the furnishing all equipment, labor and materials necessary to provide joint sealant installations which are complete in every respect and of the composition and quality as specified herein.
- B. The required applications include, but are not necessarily limited to the following:
 - 1. Pavement and sidewalk joints subjected to foot or vehicular traffic.
 - 2. Exterior building wall joints, including joints at windows, doors and louvers.
 - 3. Flashing and coping joints.
 - 4. Miscellaneous concrete construction joints.
 - 5. Partition, ceiling, and door frame joints.
 - 6. Masonry expansion joints; exterior and interior.
 - 7. Construction joints in islands, curbing, pavement and barrier walls
- C. Sealants for glazing are specified in Section 08800.

1.3 SUBMITTALS

- A. Manufacturer's Data: Submit eight (8) copies of manufacturers' specifications, recommendations and installation instructions for each type of material and application required. Include manufacturer's published data, or letter of certification, or certified test laboratory report indicating that each material complies with the requirements and is intended generally for the applications shown.

- B. Samples: Submit three 12 inch long samples of each color required for each type of joint sealer exposed to view. Install sample between 2 strips of material similar to or representative of typical surfaces where sealer will be used, held apart to represent typical joint widths. Samples will be reviewed by the Engineer for color and texture only. Compliance with all other requirements is exclusively the responsibility of the Contractor.
- C. Guarantee: Submit two copies of written guarantee agreeing to repair or replace joint sealers which fail to perform as airtight and watertight, or fail in joint adhesion, cohesion, abrasion resistance, weather resistance, extrusion resistance, migration resistance, stain resistance, or general durability, or appear to deteriorate in any other manner not clearly specified by submitted manufacturer's data as an inherent quality of the material for the exposure indicated. The Contractor shall provide signed guarantee for a period of two years.

1.4 QUALITY ASSURANCE AND COORDINATION

- A. Prior to commencing work required by this Section, the Contractor shall examine the areas and conditions which exist where joint sealer work is to be performed and notify the Engineer in writing of any conditions which are in conflict with requirements of the Contract Documents and are detrimental to the proper and timely completion of the Work. Do not proceed with the work until unsatisfactory conditions have been corrected.
- B. Do not proceed with installation of sealants under adverse weather conditions, or when temperatures are below or above the manufacturer's recommended limitations for installation. Proceed with the work only when temperatures are below or above manufacturer's recommended limitations for installation. Proceed with the work only when forecasted weather conditions are favorable for proper cure and development of high early bond strength. Wherever joint width is affected by ambient temperature variations, install elastomeric sealants only when temperatures are in the lower third of manufacturer's recommended installation temperature range.

PART 2 - MATERIALS

2.1 MATERIALS

- A. Colors: For exposed materials provide color as indicated or, if not indicated, as selected by Engineer from manufacturer's standard colors. For concealed materials, provide the color which has the best overall performance characteristics.
- B. Hardness: As recommended by manufacturer for application shown, unless otherwise indicated or required by the Engineer.
- C. Modulus of Elasticity: Provide the lowest available modulus of elasticity which is consistent with exposure to weathering, indentation, vandalism, abrasion, support of loading, and other requirements.

- D. Compatibility: Before purchase of each required material, confirm its compatibility with each material it will be exposed to in the joint system. Notify the Resident of potential problems.
- E. Size and Shape: As shown or, if not shown, as recommended by the manufacturer and approved by the Resident for the type and condition of joint, and for the indicated joint performance or movement.
- F. Grade of Sealant: For each application, provide the grade of sealant (non-sag, self-leveling, no-track, knife grade, preformed, etc.) as recommended by the manufacturer and approved by the Resident for the particular condition of installation (location, joint shape, ambient temperature, and similar conditions), to achieve the best possible appearance and overall performance. Grades specified herein are for normal conditions of installation.

2.2 ELASTOMERIC SEALANTS

- A. Foot Traffic Joints: Two-component polyurethane sealant; polyurethane- based, 2-part elastomeric sealant, complying with FS TT-S00227E, Type 1, Self-leveling, Class A. Provide one of the following:

Pecora NR-200; Pecora
 Sonolastic Pavement Joint Sealant; Sonneborn/Contech, Inc.
 Tremco THC - 900/901; Tremco

- B. Exterior Joints and Interior Moving Joints: Polymeric base sealant; modified polyurethane rubber, 2 or 3 part elastomeric sealant complying with FS TT-S00227E, Type II, Non-sag, Class A. Provide one of the following:

Dymeric Sealant; Tremco
 Dynatrol II; Pecora
 Sonolastic NP-2; Sonneborn/Contech Inc.

Note: Wherever polyurethane sealants are in contact with anodized aluminum, the sealant manufacturer's recommended primer shall be used.

2.3 NON-ELASTOMERIC SEALANTS

Interior Non-moving and Non-watertight Joints: One-component, non-staining, non-sagging, non-bleeding acrylic emulsion base latex sealant. Use only at interior joints where movement is not likely and watertightness is not necessary. Sealant shall be "Mono" by Tremco or approved equal by Pecora or Sika.

2.4 JOINT FILLERS

- A. Bituminous and Fiber Joint Filler:
- B. Provide resilient and non-extruding type premolded bituminous impregnated fiberboard units complying with ASTM D 1751, FS HH-F-341, Type 1 and AASHTO M 213. Pro-

vide where concrete slabs meet walls and similar isolation points as shown on the Drawings or directed by the Engineer.

- C. Joint Primer/Sealer: Provide the type of joint primer/sealer recommended by the sealant manufacturer for the joint surfaces to be primed or sealed.
- D. Bond Breaker Tape: Self-adhering polyethylene tape or other plastic tape as recommended by the sealant manufacturer to be applied to surfaces where bond of sealant to the substrate or joint filler or backer rod must be avoided for proper performance of sealant.
- E. Sealant Backer Rod: Compressible rod stock of polyethylene foam, polyethylene jacketed polyurethane foam, butyl rubber foam, neoprene foam or other flexible, permanent, durable, closed-cell, non-absorptive, non-gassing material as recommended for compatibility with sealant by the sealant manufacturer and approved by the Engineer. Install backer rod behind the sealant in all exterior and interior masonry expansion joints unless otherwise detailed.
- F. Compressible Filler and Fire-rated Sealant: Filler shall be "Polytite" precompressed expanding tape as manufactured by Sandell Mfg. Co. or approved equal by W. R. Grace or Willseal. Sealant shall be approved gun-grade material by 3M Co. or Hilti.

PART 3 - EXECUTION

3.1 MANUFACTURER'S INSTRUCTIONS

Comply with manufacturer's printed instructions except where more stringent requirements are shown or specified, and except where manufacturer's technical representative directs otherwise.

3.2 JOINT PREPARATION

- A. Clean joint surfaces immediately before installation of sealant. Remove dirt, insecure coatings, moisture and other substances which would interfere with bond of sealant. Etch concrete and masonry joint surfaces as recommended by sealant manufacturer. Roughen vitreous or glazed joint surfaces if recommended by sealant manufacturer.
- B. Prime joint surfaces wherever shown or recommended by the sealant manufacturer. Do not allow primer to spill or migrate onto adjoining surfaces.
- C. At exterior masonry joints where flexible thru-wall flashing has been left extended 4 inches beyond the wall, carefully secure the flashing to the upper masonry wall in order to prepare the joint to receive sealant.

3.3 INSTALLATION

- A. Set joint filler units at proper depth and position in the joint to coordinate with other

work, including the installation of bond breakers and backer rods. Do not leave voids or gaps between the ends of joint filler units; bond ends together as recommended by the manufacturer.

- B. Install sealant backer rod for elastomeric sealants, except where shown to be omitted or recommended to be omitted by sealant manufacturer for the application shown.
- C. Take care to ensure that sealant does not cover any weep holes.
- D. After the joints where the flexible thru-wall flashing occurs have been sealed and the sealant has cured sufficiently to prevent deformation of the joint, carefully cut off the extended thru-wall flashing to protrude 1/8 inch beyond the end of the horizontal leg of any exposed steel lintel at a window or door opening.
- E. Install bond breaker tape wherever shown and required by the manufacturer's recommendations to ensure that elastomeric sealants will perform properly.
- F. Employ only proven installation techniques which will ensure that sealants will be deposited in uniform, continuous ribbons without gaps or air pockets, and with complete "wetting" of the joint bond surfaces on opposite sides. Except as otherwise indicated, fill sealant rabbet to a slightly concave surface, slightly below adjoining surfaces. Where horizontal joints are between a horizontal surface and vertical surface, fill joint to form a slight cove so that joint will not trap moisture and dirt.
- G. Install sealant to depths as shown or, if not shown, as recommended by the sealant manufacturer but within the following general limitations, measured at the center (thin) section of the bead.

For sidewalks, pavements and similar joints sealed with elastomeric sealants and subject to traffic and other types of abrasion and indentation exposures, fill joints to a depth equal to 75% of joint width, but neither more than 3/4 inch deep nor less than 3/8 inch deep.

For normal moving joints sealed with elastomeric sealants but not subject to traffic, fill joints to a depth equal to 50% of joint width, but neither more than 1/2 inch deep nor less than 1/4 inch deep.

For joints sealed with non-elastomeric sealants fill joints to a depth in the range of 75% to 125% of joint width.

- H. Do not allow sealants or compounds to overflow or spill onto adjoining surfaces or glass, or to migrate into the voids of adjoining surfaces. Clean such surfaces by whatever means may be necessary to eliminate evidence of spillage, as approved by the Engineer.
- I. Recess exposed edges of gaskets and joint fillers slightly behind adjoining surfaces, unless otherwise shown, so that compressed units will not protrude from the joint.
- J. Bond ends of gaskets together with adhesive or by other means as recommended by the manufacturer to ensure continuous watertight and airtight performance. Miter-cut and bond ends at corners unless molded corner units are provided.

3.4 CURING AND PROTECTION

Cure sealants in compliance with manufacturer's instructions and recommendations to obtain high early bond strength, internal cohesive strength and surface durability. Advise the Contractor of procedures required for the cure and protection of joint sealers during the construction period, so that they will be without deterioration or damage (other than normal wear and weathering) at the time of Authority's acceptance.

END OF SECTION

SECTION 08110STEEL DOORS AND FRAMES

PART 1 – GENERAL

1.1 RELATED DOCUMENTS

- A. Examine Drawings, Contract Conditions all other Sections of the Specifications for requirements which affect work of this Section whether or not such work is specifically mentioned in this Section.
- B. Coordinate work with that of all other trades affecting, or affected by work of this Section. Cooperate with such trades to assure the steady progress of all Project work.

1.2 DESCRIPTION

- A. Standard steel doors and frames (including transoms and louver frames) are indicated on the Drawings and details, and are itemized in the Door Schedule. The work includes furnishing all materials, equipment, labor and supervision, and performing all operations necessary to furnish and install steel doors and frames complete in every respect, as shown on the Drawings, as specified herein, and as is additionally required to properly complete the work.
- B. The application of finish hardware for steel doors is part of the work of this section but hardware is provided under Section 08700.
- C. Furnishing and installing steel frames for louvers is part of the work of this section. Furnishing and installing louvers is specified under Section 10200.
- D. Glass and glazing will be performed under Section 08800.

1.3 QUALITY ASSURANCE

- A. Provide doors and frames complying with Steel Door Institute "Recommended Specifications: Standard Steel Doors and Frames" (SDI-100) and complying with these specifications. Doors shall be Grade II, Heavy Duty, Model 1, galvanized at exterior locations; face sheets for exterior doors shall be 16 gage, face sheets for interior doors shall be 18 gage. If a conflict should exist between the standard and the specifications, the more stringent or conservative requirement shall apply.

1.4 SUBMITTALS

- A. Product Data: Submit for the Engineer's approval, eight (8) copies of manufacturer's specifications for fabrication and installation, including data substantiating that products comply with specified codes and requirements. Also provide technical data for prime paint material and application.

- B. Shop Drawings: Submit for the Engineer's approval, one transparency and three prints of drawings to be used for the fabrication and installation of steel doors and frames. Include details of each frame type, elevations of door design types, conditions at openings, details of construction, location and installation requirements of finish hardware and reinforcements, and details of joints, connections, anchorages and accessory items.
- C. Provide a schedule of doors and frames using same reference numbers for details and openings as those on the Contract Drawings.

1.5 DELIVERY, STORAGE AND HANDLING

- A. Deliver materials cartoned or crated to provide protection during transit and jobsite storage.
- B. Inspect materials upon delivery for damage. Minor damage may be repaired provided finished items are equal in all respects to new work and acceptable to the Engineer, otherwise, remove and replace damaged items at no additional cost.
- C. Store doors and frames at the site under cover in accordance with the manufacturer's recommendations. Place units on wood dunnage at least 4 inches high, or otherwise store on floors in manner that will prevent rust and damage. Avoid use of non-vented plastic or canvas shelters which could create humidity chambers. If cartons become wet, remove them immediately. Provide 1/4 inch to 1/2 inch space between stacked doors and frames to promote air circulation.

PART 2 – MATERIALS

2.1 ACCEPTABLE MANUFACTURERS

Provide steel doors and frames by Steelcraft.

2.2 MATERIALS

- A. Hot-Rolled Steel Sheets and Strip: Commercial quality carbon steel, pickled and oiled, complying with ASTM A 568 and ASTM A 569.
- B. Cold-Rolled Steel Sheets: Commercial quality carbon steel, complying with ASTM A 366 and ASTM A 568.
- C. Galvanized Steel Sheets: Zinc-coated carbon steel sheets of commercial quality, complying with ASTM A 526 having ASTM A 525, G60 zinc coating, mill phosphatized.
- D. Supports and Anchors:
 - 1. Furnish wall anchors as required to secure frames to adjacent construction, formed of not less than 18 gage galvanized steel sheet (before galvanizing), as follows:

- a. Concrete Masonry Unit Construction: Adjustable, T-shape flat, corrugated or perforated, to suit frame size with leg not less than 3 inches wide by 10 inches long. Furnish at least 4 anchors per jamb.
- b. Floor Anchors: Provide floor anchors for each jamb and for mullions which extend to the floor, formed of not less than 0.0625 inch thick (No. 16 gage) galvanized steel sheet, as follows:
 - 1) Monolithic Concrete Slabs: Clip type anchors, with 2 holes to receive fasteners, welded to bottom of jamb and mullions.
 - 2) Head Anchors: Provide 2 anchors at head of frames exceeding 36 inch wide.
- 2. Spreader Bars: Provide 2 removable spreader bars across the bottom of frames, tack welded to jambs and mullions.
- E. Inserts, Bolts and Fasteners: Manufacturer's standard units, except hot-dip galvanize items to be built into exterior walls, complying with ASTM A 153, Class C or D, as applicable. Expansion anchors shall be "Kwik-Bolts" as manufactured by Hilti Fastening Systems or approved equal.
- F. Shop-Applied Paint: High quality rust-inhibitive baked-on enamel suitable as a base for specified finish paints.

2.3 FABRICATION

- A. Fabricate steel door and frame units (including transoms), to be rigid, neat in appearance, and free from defects, warp or buckle. Wherever practicable, fit and assemble units in manufacturer's plant. Clearly identify and match-mark work that cannot be permanently factory-assembled before shipment to assure proper assembly at the site.
- B. Fabricate exposed faces of doors, and frames for exterior door and louver units from cold-rolled steel only.
- C. Fabricate frames for interior doors, concealed stiffeners, reinforcement, edge channels, louvers and moldings from either cold-rolled or hot-rolled steel at manufacturer's option.
- D. Doors prepared for glass lights shall have the openings securely framed and shall be complete with screwless snap-in glazing beads on the non-security side.
- E. Finish Hardware Preparation:

Prepare doors and frames to receive mortised and concealed finish hardware in accordance with the approved Finish Hardware Schedule and templates provided by hardware manufacturer. Comply with applicable requirements of ANSI A 115 series specifications for door and frame preparation for hardware. Where surface mounted hardware is to be applied, frames shall have reinforcing plates.

Minimum thickness of hardware reinforcing plates shall be as follows:

Hinge reinforcements - 7 gage 1-1/4" x 10" minimum size.

Strike reinforcements - 12 gage.

Flush bolt reinforcements - 12 gage.

Closer reinforcements - 12 gage.

Reinforcements for surface-mounted hardware - 12 gage.

Locate knobs, levers, panic devices, push plates, and pulls in accordance with the requirements of ANSI A117.1-86, "Specifications for Making Buildings and Facilities Accessible to and Usable by, Physically Handicapped People" and ADA Guidelines. Locate other finish hardware items in accordance with "Recommended Locations for Builder's Hardware", published by Door and Hardware Institute.

F. Door Silencers: Except on weatherstripped frames, drill stops to receive 3 silencers on strike jambs of single-swing frames and 2 silencers on heads of double-swing frames.

G. Plaster Guards: Provide 26 gage (minimum) steel plaster guards or mortar boxes, welded to frame at back of finish hardware cutouts where mortar or other materials might obstruct hardware installation or operation.

H. Shop Painting:

Clean, treat and paint exposed surfaces of steel door and frame units, including galvanized surfaces.

Clean steel surfaces of mill scale, rust, oil, grease, dirt and other foreign materials before application of paint.

Apply shop coat of prime paint of even consistency and bake to provide a uniformly finished surface ready to receive finish paint.

2.4 STANDARD STEEL DOORS

A. Provide metal doors of the types and styles indicated on the Drawings or Schedules and complying with SDI SD 100, Grade II, Heavy Duty, Model 1, galvanized for exterior locations. Doors shall be made of commercial quality, level cold-rolled steel and free of scale, pitting or other surface defects. Face sheets for interior doors shall be not less than 18 gage. Face sheets for exterior doors shall be not less than 16 gage and shall be hot dip galvanized.

B. Flush Door Construction:

All doors shall be of the types and nominal sizes shown on the Door Schedule and approved shop drawings. Minimum door thickness shall be 1-3/4 inches.

All doors shall be strong, rigid and neat in appearance, free from warpage and buckle. Corner bends shall be true, straight and of the minimum radius for the gage of metal used.

Doors shall be reinforced, stiffened and sound deadened with impregnated kraft honeycomb core (or approved closed-cell insulation at exterior locations), completely filling the inside of the door and laminated to the inside faces of panels. Other core construction, standard with approved manufacturer's meeting specified U.L. Label requirements and providing effective sound deadening, are acceptable.

Top and bottom edges of all doors shall be closed with a continuous recessed steel channel not less than 16 gage extending the full width of the door and spot welded to both faces (hot-dip galvanized for exterior doors). Exterior doors shall have an additional flush closing hot-dip galvanized channel at their top and bottom edges with suitable openings be provided in the bottom closure to permit the escape of entrapped moisture.

Beveled edge profiles shall be provided on both vertical edges of doors.

C. Door Louvers:

Provide sightproof stationary louvers for interior doors where indicated, constructed of inverted V-shaped or Y-shaped blades formed of 24 gage cold-rolled steel set into 20 gage steel frames.

2.5 STANDARD STEEL FRAMES

Provide metal frames for doors and transoms, including frames for wood doors, of types and styles as shown on Drawings and schedules (butted and wrap-around), utilizing concealed fastenings, unless otherwise indicated.

Frames for exterior openings and interior U.L. labeled doors shall be made of commercial grade cold-rolled steel, not less than 14 gage. Exterior frames shall be hot dip galvanized steel. Frames shall be designed for a minimum 25 pounds per square foot horizontal load.

Frames for other interior openings shall be either commercial grade cold-rolled steel or commercial grade hot-rolled and pickled steel. Metal thickness for frames shall be not less than 16 gage.

Frames for exterior doors, interior masonry walls and drywall openings shall be press brake formed with 5/8" high integral stops. Corners shall be back seam and face welded with face welds ground neatly smooth.

Fabricate frames of full welded unit construction, with corners mitered, reinforced, continuously welded the full depth and width of frame, with welds dressed smooth and flush. Knock-down type frames are not acceptable. Frames shall be manufactured by the same manufacturer who is supplying the hollow metal doors.

PART 3 - EXECUTION

3.1 INSPECTION

Examine substrate and conditions under which steel doors and frames are to be installed and notify the Engineer in writing of any conditions detrimental to proper and timely completion of work. Do not proceed with work until unsatisfactory conditions have been corrected in an acceptable manner.

3.2 INSTALLATION

- A. Install hollow metal units and accessories in accordance with final shop drawings, the manufacturer's approved installation instructions, and as specified herein.
- B. Placing Frames: Comply with provisions of SDI-105 "Recommended Erection Instructions For Steel Frames", unless otherwise indicated.

Place frames prior to construction of enclosing walls and ceilings. Protect hardware securements from mortar spillage, joint compound, and other damage. Set frames accurately in position, plumbed, aligned, and securely braced until permanent anchors are set. After wall construction is completed, remove temporary braces and spreaders leaving surfaces smooth and undamaged. Door frame installation also includes setting of thresholds where applicable.

In masonry construction, locate 4 wall anchors per jamb. Building-in of anchors and grouting of frames is specified in Division 4.

Install fire-rated frames in accordance with NFPA Pamphlet No. 80.

- C. Finish Hardware:

Install finish hardware in strict accordance with the final approved shop drawings and the manufacturers' instructions, and adjust for easy action. Set locksets level and true with the proper backset. Adjust striking plates to be in exact alignment with bolts and latches. Adjust spindles and latch bolts for easy action. Set all screws flush with the metal surface without any broken or damaged heads.

All wrapping on knobs, handles, pulls, etc., furnished by the manufacturer shall be replaced on the hardware after it is installed and shall remain until final acceptance of the work, at which time the Contractor shall remove and dispose of all coverings.

- D. Door Installation:

Hang doors plumb and true with a uniform clearance at the head and jambs, in accordance with SDI-100 and NFPA Pamphlet 80, and with all hardware in perfect working order.

3.3 ADJUST AND CLEAN

- A. Prime Coat Touch-up: Immediately after erection, sand smooth rusted and damaged areas of prime coat and touch-up with compatible air-drying primer.
- B. Final Adjustments: Check and re-adjust operating finish hardware items leaving steel doors and frames undamaged and in complete and proper operating condition. Remove and replace defective work.

END OF SECTION

SECTION 08400ALUMINUM ENTRANCE DOORS AND FRAMING

PART 1 - GENERAL

1.1 RELATED DOCUMENTS

- A. Examine Drawings, Contract Conditions all other Sections of the Specifications for requirements which affect work of this Section whether or not such work is specifically mentioned in this Section.
- B. Coordinate work with that of all other trades affecting, or affected by work of this Section. Cooperate with such trades to assure the steady progress of all Project work.

1.2 DESCRIPTION

The work in this section consists of furnishing all materials, equipment, transportation, labor and supervision, and performing all operations required to furnish and install an aluminum entrance door, frame, transom, sidelite, associated hardware, and joint sealing as shown on the Drawings, as specified herein, and as is additionally required to properly complete the work.

1.3 SPECIFIED ELSEWHERE

- A. Joint sealing related to aluminum frames is part of the work of this section and shall be performed in accordance with the requirements of Section 07900, Joint Sealers.
- B. Glass and glazing shall be performed under Section 08800.

1.4 GENERAL REQUIREMENTS

- A. Aluminum entrance door, frame and transom, as detailed on the Drawings and specified herein are as manufactured by Kawneer Architectural Products. Products of similar quality and appearance manufactured by Vistawall or Wausau will be considered for use. The door detailed is a Medium Stile Kawneer "350 Entrance Door" with "451T" framing.
- B. Performance: The design and construction of the aluminum entrance doors shall be such as to pass the tests listed below.

1. Dual Moment Load Test as follows:

- a. Test sections shall consist of a standard top door corner assembly. Side rail section shall be 24 inch long and top rail section shall be 12 inch long.
- b. Anchor "top rail" positively to test bench so that corner protrudes 3 inches beyond bench edge.

- c. Anchor a lever arm (capable of supporting 300 pounds) positively to "side rail" at a point 19 inches from inside edge of "top rail". Attach weight support pad at a point 19 inches from inner edge of "side rail".
- d. Test section shall withstand a load of 270 pounds on the lever arm before reaching the point of failure which shall be considered a rotation of the lever arm in excess of 45°.

1.5 SHOP DRAWINGS AND PRODUCT DATA

Submit eight (8) copies of shop drawings showing door and frame details for approval. Submit seven copies of manufacturers' product data for door, framing, and each type of hardware required.

1.6 SAMPLES

- A. Submit two (2) sets of 12 inch long samples of extrusions and formed shapes. Include 3 or more samples in each set showing near-limits of variations in color and finish. Once approved, samples submitted under this section will establish the extreme variation in color acceptable.
- B. Submit samples of each type of hardware required.

PART 2 - MATERIALS

2.1 MATERIALS

- A. Sections shall be extruded from 6063-T3 aluminum alloy (ASTM B 221, alloy GS 10A-T5).
- B. Major portions of the door stiles shall be .125 inch in thickness; glazing molding shall be .050 inch thick.

2.2 CONSTRUCTION

- A. Doors. - The Kawneer "350 Entrance Door" shall have vertical stiles of 3-17/32 inches, top rails of 3-17/32 inches, and bottom rails of 6-17/32 inches. Corner construction shall consist of both SIGMA deep penetration welds and mechanical clip fastening. Glazing stops shall be of the snap-in type with neoprene bulb-type glazing for 1 inch insulated glass units, located on the non-security side of the door. No exposed screws shall be required to secure stops. Stops on exterior side shall be lock-in tamper proof type.
- B. Framing. - The Kawneer "451T" framing system shall provide for flush glazing on all sides with no projecting stops. Vertical and horizontal members shall have a nominal face dimension of 2 inches, a nominal depth of 4 1/2 inches, and shall provide for 1 inch insulated glass units. All entrance framing members shall be weatherstripped.

- C. Weather-stripping: Provide Kawneer "Sealair" weather-stripping system in the doors and frames consisting of a dense, semi-rigid polymeric material which remains resilient and retains its weathering ability through temperature extremes. The system shall be provided with an EPDM blade gasket sweep strip attached to the door bottom with concealed fasteners. Weather-stripping and sweep shall be compatible with the threshold provided.

2.3 FINISH

All exposed members shall be free of scratches and other surface blemishes. All aluminum shall have fluoropolymer paint coating conforming to requirements of AAMA 605.2-92. Custom color will be selected.

2.4 HARDWARE

- A. Hardware for aluminum entrance doors (including the interior vestibule doors) shall be furnished and installed by the door manufacturer except otherwise noted, and shall include the following hardware items by the manufacturers specified or approved equal.
 - 1. Pivots shall be Rixson 195xM190 (with intermediate pivot).
 - 2. Rim Exit Device shall be Von Duprin CD 98 x less pull x US 32D with cylinder and interchangeable core provided under Section 08700.
 - 3. LCN Cush-N-Stop surface closer with adjustable hold open feature or approved equal by Russwin or Sargent.
 - 4. Pull shall be Rockwood No. 158 x US 32D or approved equal by Brookline or Ives.
 - 5. Aluminum threshold shall be supplied and installed under Section 08700.
- B. Anchors and Fastenings: Furnish and install all bolts, nuts, anchors, sleeves and clips necessary for proper anchorage and support of aluminum work. All fastening devices shall be aluminum or non-magnetic stainless steel. Expansion bolts shall be stainless steel "Kwik-Bolts" as manufactured by Hilti Fastening Systems or approved equal.
- C. Brackets and Reinforcements: Manufacturer's standard high-strength aluminum units where feasible, otherwise nonmagnetic stainless steel; except, at fabricator's option, brackets not exposed to weather or abrasion may be hot-dip galvanized steel complying with ASTM A 386. Provide nonstaining, nonferrous shims for installation and alignment of metal work.
- D. Concealed Flashing: Non-magnetic stainless steel, 26 gage, type selected by manufacturer for compatibility.

PART 3 - EXECUTION

3.1 INSPECTION AND PREPARATION

Furnish inserts at proper times for setting in concrete formwork, masonry, and similar construction indicated to support work of this Section.

3.2 INSTALLATION/ERECTION

- A. General: Comply with manufacturer's instructions for protection, handling and installation of the door, fabricated components, and hardware with particular attention and care to the preservation of applied finishes and to provide a weathertight installation. Discard and/or remove and replace damaged members immediately upon discovery.
- B. Framing Erection: Install components plumb, level, accurately aligned and accurately located. Anchor components securely in place in the manner indicated on the approved shop drawings, shimming and allowing for required movement, and providing separators and insulators to prevent corrosion and electrolytic deterioration, and to prevent "freeze-up" of moving joints.
- C. Installation of Door and Finish Hardware:
 - 1. Make sure that the door, frame and transom are properly installed with square corners, plumb sides, level at the head, securely attached to surrounding construction and of the size and hand shown on the Drawings. Do not install the door in an improperly installed frame.
 - 2. Door openings shall not have more than the clearance specified by the manufacturer at sides, top, and bottom.
 - 3. Apply finish hardware in strict accordance with the final approved shop drawings and the manufacturers' instructions. Use care not to damage adjacent surfaces when installing hardware. Adjust door to be in exact alignment and hardware for easy action. Set all screws flush with the metal surface without any broken or damaged heads.
- D. Dissimilar Contact Surfaces:
 - 1. Metals - Where aluminum is placed in contact with any metal other than non-magnetic stainless steel, the aluminum contact surface shall be given a heavy brush coating of zinc chromate primer made with a synthetic resin vehicle followed by two coats of an aluminum metal paint or shall be separated with an approved non-absorptive tape or gasket.
 - 2. Masonry - Aluminum placed in contact with masonry, mortar or concrete shall be given a heavy brush coating of an approved alkali-resistant, non-migrating, bituminous paint.

- E. Sealants and Joint Fillers: Furnish and install in accordance with Section 07900, Joint Sealers.
- F. Glazing: Provided under Section 08800, Glass and Glazing.

3.3 ADJUST AND CLEAN

- A. Just prior to the completion of all work under this section, the Contractor, with the Engineer, shall inspect all portions of the work, and shall make all required adjustments and corrections to the work, leaving all operable portions in proper operating condition and insuring that all jointing is tight. In addition, each piece of finish hardware shall be inspected to see that it is undamaged and in perfect working order.
- B. Clean completed work, inside and out, promptly after erection to the Engineer's satisfaction. Remove dirt and other substances from aluminum and other affected surfaces.
- C. Remove protective coating (if any) when completion of construction activities no longer requires its retention. Removal shall be in accordance with manufacturer's instructions.
- D. Perform minor touch-up work to members with finish damage to the Engineer's satisfaction. Should the Engineer, as sole judge of acceptability of repairs, deem a repair as unsatisfactory, the Contractor shall promptly remove and replace such damaged members at no additional cost.
- E. Institute protective measures and other precautions required to assure that all metal work and doors will be without damage or deterioration, other than normal weathering, at time of acceptance.

END OF SECTION

SECTION 08500ALUMINUM WINDOWS

PART 1 - GENERAL

1.1 RELATED DOCUMENTS

- A. Examine Drawings, Contract Conditions all other Sections of the Specifications for requirements which affect work of this Section whether or not such work is specifically mentioned in this Section.
- B. Coordinate work with that of all other trades affecting, or affected by work of this Section. Cooperate with such trades to assure the steady progress of all Project work.

1.2 DESCRIPTION

- A. The work in this section consists of furnishing all materials, equipment, supplies, transportation, labor and supervision, and performing all operations required to furnish and install, weathertight, all aluminum windows, including insulating glass, as shown on the Drawings, as specified herein, and as is additionally required to properly complete the work.
- B. Related sealant and glass and glazing work are included as part of the work of this section and shall be provided in accordance with the requirements of Sections 07900 and 08800, respectively.

1.3 GENERAL

- A. The Contractor shall verify all measurements at the building site and shall be responsible for dimensions, fitting, and the proper attachment of items related to the aluminum windows. Windows shall be fixed type. Window units shall be factory fabricated insofar as possible, consisting of, as applicable, frame, sash, sills, panning, mullions, insulating glass, sealants and anchors.
- B. Storage and Protection: Materials shall be stored out of contact with the ground and under a weathertight covering. Storage shall be arranged to avoid bending, warping, or otherwise damaging the materials and to provide adequate ventilation.
- C. Window frames, mullions, panning, screens, etc., shown on the Drawings are Kawneer 451T framing system as manufactured by Kawneer Co., Inc. Similar thermal-break windows by other reputable manufacturers will be considered provided they meet or exceed the requirements of the Kawneer windows specified. The Contractor shall obtain preliminary approval of the manufacturer's stock details from the Resident before complete shop drawings are prepared. Final approval will be based upon complete shop drawings showing all features of window fabrication and conditions of installation as detailed on the Drawings. All detailed requirements must be met.

- D. Performance Requirements: Windows shall exceed the current specifications of the Architectural Aluminum Manufacturers Association (AAMA) and shall bear the Quality Certified Seal of AAMA for PA3-A3HP.

1.4 SUBMITTALS

- A. Submit eight (8) copies of product data for all materials and shop drawings to the Engineer for approval. Shop drawings shall indicate the location and elevation of each type of window and shall show type and location of hardware, weather-stripping, locations of sealants, details of construction, including insulated glass/aluminum spandrel panels, glazing, anchorages, methods of assembly, and installation of all components.
- B. Submit two (2) sets of 12 inch long samples of extrusions and formed shapes. Include 3 or more samples in each set showing near-limits of variations in color and finish. Once approved, samples will establish the extreme variation in color acceptable.
- C. Submit samples of each type of hardware required.

PART 2 - MATERIALS

2.1 GENERAL

- A. Frames unless otherwise noted shall be fabricated from extruded aluminum sections incorporating a continuous rigid polyurethane thermal barrier (break). Members shall not be less than 4-1/2 inches deep from front to back. Face dimensions of frames shall be approximately 2 inches; webs and flanges shall be not less than .090 inch thick.
- B. Glass: Shall be 1" insulating units as specified in Section 08800, Glass and Glazing.
- C. Sealants: Shall be as specified in Section 07900, Joint Sealers.

2.2 CONSTRUCTION

- A. Fabricate aluminum windows in accordance with the approved shop drawings.
- B. All joints in aluminum framing shall be hairline and mechanically fastened.
- C. The back wall of the polyurethane pocket shall be removed to form a thermal barrier system. There shall be no frame members, corner construction or hardware application that bridges or violates the thermal barrier in any way.
- D. Special acrylic or butyl small-joint sealer shall be applied at all intersections to provide permanent watertight joints. Sections shall be designed to provide a flush condition of frame and vent members on the exterior and to position all glass in the same vertical plane.

2.3 GLAZING

Windows shall be arranged for inside glazing with aluminum extruded snap-in glazing beads designed to accommodate 1 inch insulating glass units and 1 inch insulated spandrel panels. Snap-in glazing beads shall securely interlock into the extruded window sections without extending underneath the glass or spandrel panel, or bridging the thermal barrier. Glazing rabbet legs shall be a minimum of 3/4 inches in height.

2.4 FINISH

All exposed aluminum for windows, sills, panning, and flashing shall have a fluoropolymer paint coating conforming to requirements of AAMA 605.2-92. Custom color will be selected to match aluminum storefront framing and door specified in Section 08400.

PART 3 - EXECUTION

3.1 INSTALLATION

- A. Windows shall be installed in strict accordance with the approved shop drawings and the manufacturer's approved installation instructions, without forcing or distortion so that sills and heads are level and jambs are plumb. Window frames shall be securely anchored in place with heavy gauge anchors, four (4) per jamb.
- B. Glass units shall be furnished, installed and cleaned in accordance with the applicable requirements of Section 08800, Glass and Glazing.
- C. Sealants shall be furnished and installed in accordance with the requirements of Section 07900, Joint Sealers.

3.2 ADJUSTMENT AND CLEANING

- A. After installation, glass and metal surfaces shall be cleaned and any staining or discoloring of the finish shall be restored to the Engineer's satisfaction or the unit shall be replaced at no additional cost. All other work detrimentally affected by the installation of the windows shall also be cleaned or otherwise restored to the Resident's satisfaction.

END OF SECTION

SECTION 08700

FINISH HARDWARE

PART 1 - GENERAL

1.1 RELATED DOCUMENTS

- A. Examine Drawings, Contract Conditions all other Sections of the Specifications for requirements which affect work of this Section whether or not such work is specifically mentioned in this Section.
- B. Coordinate work with that of all other trades affecting, or affected by work of this Section. Cooperate with such trades to assure the steady progress of all Project work.

1.2 DESCRIPTION

The work in this section consists of furnishing all labor, materials, equipment and transportation and performing all operations required to furnish all finish hardware as shown on the drawings and specified herein.

1.3 SPECIFIED ELSEWHERE

- A. The following related work items shall be furnished and installed under other sections of these specifications as indicated.
 - 1. Hardware for Aluminum Entrance Door - Section 08400.
 - 2. Hardware for Cabinets - Section 06400.
 - 3. Installation of hardware for metal doors will be performed under Section 08110.

1.4 GENERAL

- A. No finish hardware shall be delivered until all operations causing dampness have been completed. Care shall be taken to protect hardware from scratching and foreign matter, such as paint, joint compound, etc.
- B. All items of hardware shall be packed in approved manufacturers' containers with all trimmings, bolts, screws, etc., as required. Each container shall be accurately labeled and marked with an item location corresponding to the number listed on the approved Finish Hardware Schedule.
- C. Strikes for locks shall be box type with sufficient lip protection to protect frames and trim.
- D. All locks shall be construction master keyed. Four (4) construction master keys shall be furnished. All locks shall be set to new building master keys as directed by the

Resident. Furnish six (6) master keys and two keys for each lock.

- E. Where size or shape of members is such as to prevent the use of the types specified, hardware shall be furnished of suitable type having as near as practicable the same operation and quality as the specified type; sized to be adequate for the required service, and approved by the Engineer.

1.5 SUBMITTALS

As part of the submission of shop drawings, the Contractor shall submit to the Engineer for review eight (8) copies of the schedule of finish hardware to be provided, giving manufacturers' names, catalog number references, type numbers, finish, and location of each item of hardware (identified with the door for which it is intended), and also the catalog cuts for each hardware item.

PART 2 - MATERIALS

2.1 MATERIALS

- A. All finish hardware shall be of the best grade of solid metal, entirely free from imperfections in manufacture and finish. Finish shall be US 26D Satin Chromium Plated and US 32D Satin Stainless Steel, as applicable. Door closer units shall have sprayed lacquer finish to match balance of hardware.
- B. The following items and manufacturers thereof indicate the quality and design of the hardware required.
1. Hinges: All door butts shall be Stanley No. FBB199 (US 32D), shall conform to ANSI A156.1 (A2111). Equivalent hinges manufactured by Hager Hinge Co. are also acceptable.
 2. Locksets shall Best Lock 35H x 16H x L x US 32D with anti-friction latch bolts and interchangeable cores. Function will be determined at time of hardware submittal by the Resident at no additional cost.
 3. Door Closers shall be LCN Smoothee Series with parallel arm "Cush-N-Stop" for push side and LCN's heaviest duty arm for pull side. Comparable closers manufactured by Sargent and Russwin will be considered for use. Provide coordinator at pairs of doors with adjustable safety release and internal override.
 4. Silencers shall be manufactured by Trimco, Sargent & Co. or Glynn-Johnson.
 5. Thresholds shall be of a style approved by the Resident, manufactured by Reese, National Guard or Pemko. All exterior doors shall have an extruded aluminum threshold with an integral slip-resistant surface set in sealant to provide watertight condition. Thresholds shall be secured to floor construction with suitable stainless steel flat head screws in expansion shields. Slip-resistant coating shall be equal to

"PemKote" by Pemko. If size is not shown, provided threshold width equal to jamb depth.

Threshold - Type A: Pemko 171A w/PemKote
Threshold - Type B: Pemko 270A and 282A, each with 1/4" high w/PemKote.

6. Kick plates and mop plates shall be 22 gage stainless steel, 8" high by width of door less 2", attached with stainless steel screws, as manufactured by Brookline, Ives or Rockwood.
7. Weather-stripping Systems shall be provided at all exterior doors and frames consisting of a dense, semi-rigid polymeric material which remains resilient and retains its weathering ability through temperature extremes. Weather-stripping and sweep shall be compatible with the threshold provided. Weather-stripping shall be of a style approved by the Resident, manufactured by Reese, National Guard or Pemko.

Door Shoe: Pemko 234AV (cold weather seal)
Jamb & Head: Pemko 319CR
8. Floor Stops, and Wall Stops shall be manufactured by H.B. Ives Co., Brookline Industries Inc., Stanley, or Glynn-Johnson.
9. Exit Device and Pull: Refer to Section 08400.
10. Flush Bolts: Provide mortised manual and automatic self-latching flush bolts with 3/4" minimum throw by Burns Manufacturing Company, DCI, Hiawatha, or Trimco.
11. Electric Strike: Provide Galaxy Model 1006-12/24D-630 X KM-630 with removable core for Best Cylinder.
12. Electric Lock: Provide self-contained mortised unit with internal, battery-powered, self-contained electronic lock; consisting of complete lockset, motor-driven lock mechanism, and actualting device, enclosed zinc-dichromatic-plated, wrought steel case, and strike that suits installation condition. Provide key override, low battery detection and warning, LED status indicators, and ability to program the lock. Provide Best Access Systems Mortised latchbolt.
13. Electric Hinges: Provide heavy duty electric hinge by Stanley or Hager.
14. Electric Hold Open Devices: Wall-mounted unit with strike plate attached to swinging door; coordinated with fire detectors and interface with fire alarm system for labeled fire-rated door assemblies. Provide units by Dorma, Hager, or Sargent.

2.2 FINISH HARDWARE SCHEDULE

SET NO. 1

For Door No. 101, 102 & 104 and All Tunnel Stair Enclosure Doors (Aluminum Entrance Door)

Provide 1 Electric Strike
Provide 1 Threshold
1 Card Reader (provided by The Authority)
1 Power Supply

SET NO. 2

For Door No. 103

1 1/2 Pair Butts
1 Card Reader (provided by The Authority)
1 Electric Strike
1 Lockset
1 Closer
1 Kick Plate
1 Head and Jamb Weatherstripping Set
1 Door Bottom
1 Threshold
1 Power Supply

SET NO. 3

For Door No. 105

1 Door Stop
Balance of Hardware by Aluminum Door Installer

SET NO. 4

For Door Nos. 106 & 107 (Rated – 107)

1 1/2 Pair Butts
1 Electric Strike
1 Lockset
1 Closer
1 Kickplate
1 Door Stop
3 Silencers
1 Card Reader (provided by The Authority)
1 Power Supply

SET NO. 5

For Door Nos. 108 & 109

1 1/2 Pair Butts
1 Push/Pull Set

1 Closer
1 Kickplate
1 Door Stop
3 Silencers

SET NO. 6

For Door Nos. 004, 005 & 006 (Rated)

1 ½ Pair Butts
1 Latchset
1 Closer
1 Kickplate
1 Door Stop
3 Silencers

SET NO. 7

For Door Nos. 003 (Rated)

1 ½ Pair Butts
1 Lockset
1 Closer
1 Kickplate
1 Door Stop
3 Silencers

SET NO. 8

For Pair Door Nos. 002, 007 & 008 (Rated)

3 Pair Butts
1 Lockset (Active Leaf)
2 Flush Bolts (Inactive Leaf)
2 Closers
1 Coordinator
2 Kickplates
1 Door Stop (Door 002 Only)
2 Silencers

SET NO. 9

For Door Nos. 009 & 010 (Rated)

1 ½ Pair Butts
1 Lockset
1 Closer
1 Kickplate
2 Silencers

SET NO. 10

For Pair Door No. 011 (Rated)

5 Butts
1 Electrified Butt (Active Leaf)
1 Electrified Lockset (Active Leaf)
2 Closers
1 Coordinator
2 Automatic Flush Bolts (Inactive Leaf)
2 Kickplates
2 Electro-Magnetic Hold-Open Devices
2 Silencers
1 Card Reader (provided by The Authority)
1 Power Supply

SET NO. 11

For Door Nos. 001, 111 & 112 (Rated)

1 1/2 Pair Butts
1 Latchset
1 Closer
1 Kickplate
1 Electro-Magnetic Hold-Open Device
3 Silencers
1 Power Supply

SET NO. 12

For Door No. 110 (Rated)

1 1/2 Pair Butts
1 Latchset
1 Closer
1 Kickplate
3 Silencers

PART 3 - EXECUTION

3.1 INSTALLATION

- A. Hardware shall be installed accurately in accordance with the manufacturers' templates and approved instructions.
- B. All knobs, levers, panic devices, push plates, pulls and other hardware shall be installed in accordance with the requirements of ANSI A117 and ADAAG.

END OF SECTION

SECTION 08800

GLASS AND GLAZING

PART 1 - GENERAL

1.01 RELATED DOCUMENTS

- A. Examine Drawings, Contract Conditions all other Sections of the Specifications for requirements which affect work of this Section whether or not such work is specifically mentioned in this Section.
- B. Coordinate work with that of all other trades affecting, or affected by work of this Section. Cooperate with such trades to assure the steady progress of all Project work.

1.02 DESCRIPTION

- A. The term "glass" includes prime, processed and fabricated glass products. "Glazing" includes glass installation and all materials used to install glass. Types of work include glass and glazing for:
 - 1. Exterior aluminum entrance door, associated windows, and transom.
 - 2. Exterior hollow metal door vision lights.
 - 3. Glass for aluminum windows.
 - 4. Aluminum Spandrel Panels

1.03 QUALITY ASSURANCE

- A. Prime Glass Standard: Comply with FS DD-G-451.
- B. Heat Strengthened and Fully Tempered Glass Standard: FS DD-G-1403.
- C. Safety Standards for Hazardous Locations: Conform to requirements of Building Code which applies to the Project and to all local ordinances and regulations.

1.04 SUBMITTALS

- A. Submit 2 samples, 12 inches square, of each glass type specified. Submit 12 inch lengths of installed (mocked-up) glazing systems including metal framing and sealant components. Submit insulating glass samples with completed edge seal construction. Hermetic seal need not be maintained.
- B. Submit eight (8) copies of manufacturer's specifications, product information sheets, warranties, and installation instructions and recommendations.

1.05 JOB CONDITIONS

Meet with glazier and other trades affected by glass installation prior to beginning of

installation. Do not perform work under adverse weather or job conditions. Install liquid sealants only when temperatures are within lower or middle third of temperature range recommended by manufacturer.

1.06 SPECIFIED PRODUCT WARRANTY

- A. Provide insulating glass manufacturer's written warranty, agreeing to, within specified warranty period, furnish FOB project site, replacement units for insulating glass units which have defective hermetic seals (excluding that due to glass breakage); defined to include intrusion of moisture or dirt, internal condensation at temperatures above -20°F (-31°C), deterioration of internal glass coatings, and other visual evidence of seal failure or performance failure; provided manufacturer's instructions for handling, installing, protecting and maintaining units have been adhered to during warranty period.
- B. Warranty period is 10 years after seal date permanently imprinted on units, but in no case less than 9 years after the date of substantial completion.

PART 2 - MATERIALS

2.01 ACCEPTABLE MANUFACTURERS

Subject to compliance with requirements, manufacturers offering products which may be incorporated in the work include, but are not limited to, the following:

Pilkington
PPG Industries, Inc.
Guardian Industries
Ford Glass Company
Laminators, Inc.

2.02 PRIME GLASS

Float Glass: Type I, Quality q3, clear or tinted glass as indicated.

2.03 PROCESSED GLASS

Tempered Glass: Provide clear or tinted glass as indicated, which has been heat treated to strengthen glass in bending to not less than 4.5 times annealed strength. Tong marks shall not be visible in glass after it is glazed in openings. Glass shall be of the thicknesses indicated, equal to Pilkington Tempered Glass. Color will be selected by the Architect.

2.04 FABRICATED GLASS UNITS

- A. Laminated Safety Glass: Laminate 2 sheets of clear or tinted float or tempered glass (as specified) with a 30-mil interlayer of poly-vinyl butyral, by manufacturer's standard heat-plus-pressure process with dirt, air pockets and foreign substances excluded; 1/4 inch thick if not otherwise indicated. Units shall be equal to Pilkington Laminated Glass. Color will be Pilkington Artic Blue High Performance Tint.
- B. Tinted Sealant-Edged Insulating Glass: Provide manufacturer's standard double-pane with a seal classification of "A" as tested and certified by IGCC, with a permanent hermetically sealed, dry air or gas filled space of width indicated, dual-sealed edge construction, edge seal consisting of twin primary sealant beads of polyisobutylene, positioned and retained by tubular aluminum spacer bar. Provide manufacturer's standard protective, rust resistant metal edge banding on insulating glass units, labeled with fabricator's name and date of seal. Units shall be equal to Pilkington Insulated Glass. Color will be Pilkington Artic Blue High Performance Tint.

2.05 SPANDREL PANELS

- A. Spandrel panels shall be 1" thick aluminum clad units in color indicated and shall be sealed into aluminum storefront frame system per manufacturer's instructions.

2.06 GLASS TYPES

Provide the following glass types as indicated in the Glazing Schedule:

Type A - 1 inch tinted insulated: 1/4 inch tinted exterior light, 1/2 inch desiccated air space, 1/4 inch interior light.

Type B - Same as Type A but both lights tempered.

Type C - 1 inch obscured tinted insulated: 1/4 inch tinted exterior light, 1/2 inch desiccated air space; 1/4 inch clear obscure (frosted or sandblasted) interior light.

Type D – 1/4" clear tempered interior light.

Type E – 1/4" clear fire rated interior light, similar to Firelite.

Type F – 1" spandrel panel: "Omega-Lite" panels by Laminators, Inc. Color shall be "Slate Blue Smooth".

2.07 GLAZING SEALANTS AND COMPOUNDS

Provide color of exposed sealant/compound as selected by Engineer from manufacturer's standard colors. Comply with manufacturer's recommendations for selection of hardness, depending upon the location of each application, conditions at time of installation, and performance requirements. Carefully select materials for compatibility with surfaces contacted in the installation.

2.08 GLAZING GASKETS

- A. Molded Neoprene Glazing Gaskets: Molded or extruded neoprene gaskets of the profile and hardness required for watertight construction. Glazing gaskets shall be standard for the glass framing systems supplied and shall be purchased from the frame manufacturer unless otherwise approved.
- B. Vinyl Foam Glazing Tape: Closed cell, flexible, self-adhesive, non-extruding, polyvinyl chloride foam tape; recommended by manufacturer for exterior, exposed, watertight installation of glass, with only nominal pressure in the glazing channel; complying to ASTM D 1667.

2.09 MISCELLANEOUS GLAZING MATERIALS

- A. Cleaners, Primers and Sealers: Type recommended by sealant and gasket manufacturers.
- B. Setting Blocks: Neoprene or EPDM, 70-90 durometer hardness, with proven compatibility with sealants used.
- C. Spacers: Neoprene or EPDM, 40-50 durometer hardness, with proven compatibility with sealants used.
- D. Compressible Filler (Rod): Closed cell or waterproof-jacketed rod stock of synthetic rubber or plastic foam, proven to be compatible with sealants used, flexible and resilient, with 5-10 psi compression strength for 25% deflection.

PART 3 - EXECUTION

3.01 STANDARDS AND PERFORMANCE

- A. Watertight and airtight installation of each piece of glass is required. Each installation must withstand normal temperature changes, wind loading, impact loading (for operating units) without failure, including loss or breakage of glass, failure of sealants or gaskets to remain watertight and airtight, deterioration of glazing materials and other defects.
- B. Protect glass from edge damage during handling and installation, and subsequent operation of glazed components of the work. During installation, discard units with edge damage and other imperfections.
- C. Glazing channel dimensions shown are intended to provide for necessary bite on glass, minimum edge clearance and adequate sealant thicknesses, with reasonable tolerances. Adjust as required by job conditions at time of installation.
- D. Comply with combined recommendations and technical reports of manufacturers of glass and glazing products as used in each glazing application, and with

recommendations of Flat Glass Marketing Association "Glazing Manual," except where more stringent requirements are indicated or specified.

- E. Install insulating glass units to comply with recommendations by Sealed Insulating Glass Manufacturers Association, except as otherwise specifically indicated or recommended by glass and sealant manufacturers.

3.02 PREPARATION FOR GLAZING

- A. Clean glazing channel and other framing members to receive glass immediately before glazing. Remove coatings which are not firmly bonded to substrate. Remove lacquer from metal surfaces where elastomeric sealants are used.
- B. Apply primer or sealer to joint surfaces where recommended by sealant manufacturer.

3.03 GLAZING

- A. Install setting blocks of proper size in sill rabbet, located 1/4 of the glass width from each corner. Set blocks in thin course of heel-bead compound.
- B. Provide spacers inside and out, of proper size and spacing, for glass sizes larger than 50 united inches, except where gaskets or preshimmed tapes are used for glazing. Provide 1/8 inch minimum bite of spacers on glass and use thickness equal to sealant width, except with sealant tape use thickness slightly less than final compressed thickness of tape.
- C. Set units of glass in each series with uniformity of pattern, draw, bow and similar characteristics.
- D. Miter cut and bond ends together at corners where gaskets are used for channel glazing so that gaskets will not pull away from corners and result in voids or leaks in the glazing system.

3.04 CURING, PROTECTION AND CLEANING

- A. Protect glass from breakage immediately upon installation. Do not apply markers to surfaces of glass. Remove non-permanent labels and clean surfaces. Cure sealants as necessary to provide high early strength and durability.
- B. Remove and replace glass which is broken, chipped, cracked, abraded or damaged in other ways during the construction period, including natural causes, accidents and vandalism.
- C. Wash and polish glass on both faces not more than 4 days prior to date scheduled for inspection intended to establish date of Substantial Completion. Comply with glass manufacturers' recommendations for final cleaning.

END OF SECTION

SECTION 08900OPERABLE WALL LOUVERS

PART 1 - GENERAL

1.1 SUMMARY

- A. Section includes operable, extruded-aluminum louvers. Intake Air Louvers are for Outside air intake, and shall be designed and constructed as double-doors for access from Boiler and Mechanical Rooms to Areaways.

1.2 ACTION SUBMITTALS

- A. Product Data: For each type of product indicated.
 - 1. For louvers specified to bear AMCA seal, include printed catalog pages showing specified models with appropriate AMCA Certified Ratings Seals.
- B. Shop Drawings: For louvers and accessories. Include plans, elevations, sections, details, and attachments to other work. Show frame profiles and blade profiles, angles, and spacing.
 - 1. Wiring Diagrams: For power, signal, and control wiring for motorized operable louvers.
 - 2. Provide shop drawings for operable louvers designed and constructed as double doors for opening and closing for access to the areaways from the boiler and mechanical rooms. Provide additional details for installing in masonry openings, and including removable louver plenums and ductwork behind the louvers. Each double door shall include 2-separate 3-ft doors, hinged. Each 3-ft door shall include independent set of electrical actuators.
- C. Samples: For each type of metal finish required.
- D. Delegated-Design Submittal: For louvers indicated to comply with structural and seismic performance requirements and design criteria, including analysis data signed and sealed by the qualified professional engineer responsible for their preparation.

1.3 INFORMATIONAL SUBMITTALS

- A. Product Test Reports: Based on tests performed according to AMCA 500-L.
- B. Sample warranties.

1.4 QUALITY ASSURANCE

- A. Welding Qualifications: Qualify procedures and personnel according to the following:

1. AWS D1.2/D1.2M.
2. AWS D1.3/D1.3M.
3. AWS D1.6/D1.6M.

B. Provide AMCA certified rating and seal.

1.5 WARRANTY

A. Special Finish Warranty: Manufacturer agrees to repair or replace components on which finishes fail in materials or workmanship within specified warranty period.

1. Warranty Period: 5- years from date of Substantial Completion.
2. Provide storage and handling of louvers and shipped loose items.

PART 2 - PRODUCTS

2.1 PERFORMANCE REQUIREMENTS

A. Delegated Design: Design louvers, including comprehensive engineering analysis by a qualified professional engineer, using structural and seismic performance requirements and design criteria indicated.

B. Structural Performance: Louvers shall withstand the effects of gravity loads and the following loads and stresses within limits and under conditions indicated without permanent deformation of louver components, noise or metal fatigue caused by louver-blade rattle or flutter, or permanent damage to fasteners and anchors. Wind pressures to the face of the building shall be considered to act normal.

1. Wind Loads: Determine loads based on pressures as indicated on Drawings.
2. Wind Loads: Determine loads based on a uniform pressure of 20 lbf/sq. ft. (957 Pa), acting inward or outward.

C. Seismic Performance: As indicated on Drawings.

D. Seismic Performance: Louvers, including attachments to other construction, shall withstand the effects of earthquake motions determined according to:

1. Design earthquake spectral response acceleration, short period (Sds) for Project is in Portland, Maine.
2. Component Importance Factor: Verify with factor on structural drawings.

E. Louver Performance Ratings: Provide louvers complying with requirements specified, as demonstrated by testing manufacturer's stock units identical to those provided, except for length and width according to AMCA 500-L.

- F. UL and NEMA Compliance: Provide motors and related components for motor-operated louvers that are listed and labeled by UL and comply with applicable NEMA standards.

2.2 OPERABLE EXTRUDED-ALUMINUM LOUVERS

- A. Louver Construction and Operation: Provide operable louvers with extruded-aluminum frames and blades of not less than 0.080-inch (2.03-mm) nominal thickness, and with operating mechanisms to suit louver sizes.

1. Hand operation with push bars.
2. Crank operation with removable-crank operator in sill or jamb.
3. Motor operation with two-position, spring-return application with power on, motor closes louver; with power off, spring opens louver; 110-V, 60-Hz motor and limit switch, two-direction, 110-V, 60-Hz motor and limit switches; equipped with [frame-mounted switch, and terminals for controlling devices.

- B. Multiple-Blade Operable Louver:

1. Louver Depth: 6 inches (150 mm), minimum.
2. Blade Type: Drainable.
3. Accessories: Equip louvers as follows:
 - a. Vinyl blade-edge gaskets for each louver blade.
 - b. Vinyl blade gaskets for edge sealing for each blade.
 - c. Actuators: Provide electrical motor actuators for louver operation. Provide independent set of actuators for each 3-ft door of 6-ft double door louver.
4. Louver Performance Ratings:
 - a. Free Area: Not less than 40 sq. ft for the 6-ft wide x 7-ft high louver (nominal).
 - b. Point of Beginning Water Penetration: less than 500 fpm (2.5 m/s).
 - c. Air Performance: Not more than 0.050-inch wg static pressure drop at less than 500 fpm, free-area intake velocity.
 - d. Air Leakage: Not more than 3.5 cfm/sq. ft. (17.8 L/s per sq. m) of louver gross area at a differential static pressure of 0.05-inch wg (37 Pa) with operable louver blades closed.
5. AMCA Seal: Mark units with AMCA Certified Ratings Seal.

2.3 MANUFACTURERS:

1. Provide louvers as required by any of the following Manufacturers upon approval by the Engineer:
 - a. Ruskin (Basis of Design)
 - b. Greenheck

- c. Approved equal.

2.4 LOUVER SCREENS

- A. General: Provide screen at louvers indicated.
 - 1. Screen Location: Exterior face unless otherwise indicated.
 - 2. Screening Type: Insect screening.
- B. Louver Screen Frames: Same type and form of metal as indicated for louver to which screens are attached.
- C. Louver Screening for Aluminum Louvers:
 - 1. Insect Screening: Stainless steel, 18-by-18 (1.4-by-1.4-mm) mesh, 0.009-inch (0.23-mm) heavy duty wire.

2.5 MATERIALS

- A. Aluminum Extrusions: ASTM B 221 (ASTM B 221M), Alloy 6063-T5, T-52, or T6.
- B. Fasteners: Use types and sizes to suit unit installation conditions.
 - 1. Use hex-head or Phillips pan-head, tamper-resistant screws for exposed fasteners unless otherwise indicated.
 - 2. For fastening aluminum, use aluminum or 300 series stainless-steel fasteners.
- C. Postinstalled Fasteners for Concrete and Masonry: Torque-controlled expansion anchors, fabricated from stainless-steel components, with allowable load or strength design capacities calculated according to ICC-ES AC193 and ACI 318 greater than or equal to the design load, as determined by testing according to ASTM E 488/E 488M conducted by a qualified testing agency.
- D. Provide stainless steel handles, hinges and hardware.

2.6 FABRICATION

- A. Fabricate frames, including integral sills, to fit in openings of sizes indicated, with allowances made for fabrication and installation tolerances, adjoining material tolerances, and perimeter sealant joints.

2.7 ALUMINUM FINISHES

- A. Clear Anodic Finish: AAMA 611, AA-M12C22A41, Class I, 0.018 mm or thicker.

PART 3 - EXECUTION

3.1 INSTALLATION

- A. Construct louvers to be used as intake air louvers for both the mechanical and boiler rooms, and shall be constructed as double doors for access to the areaways. The handles for opening/closing the louver doors shall be located in the areaways (verified by owner).
- B. Coordinate providing ductwork and plenums behind the louvers, and shall be removable as noted on the drawings. Provide shop drawings for the louvers, plenums, and ductwork. Insulate the OA ductwork and louver plenums.
- C. Locate and place louvers level, plumb, and at indicated alignment with adjacent work. Locate louvers in masonry openings in the basement walls, as noted on the mechanical and architectural drawings.
- D. Use concealed anchorages where possible. Provide brass or lead washers fitted to screws where required to protect metal surfaces and to make a weathertight connection.
- E. Provide perimeter reveals and openings of uniform width for sealants and joint fillers, as indicated.
- F. Protect unpainted galvanized- and nonferrous-metal surfaces that are in contact with concrete, masonry, or dissimilar metals from corrosion and galvanic action by applying a heavy coating of bituminous paint or by separating surfaces with waterproof gaskets or nonmetallic flashing.

3.2 ADJUSTING

- A. Test operable louvers and adjust as needed to produce fully functioning units that comply with requirements.
- B. Restore louvers damaged during installation and construction, so no evidence remains of corrective work. If results of restoration are unsuccessful, as determined by Architect, remove damaged units and replace with new units.

END OF SECTION

SECTION 09211

GYPSUM BOARD SHAFT WALL ASSEMBLIES

PART 1 - GENERAL

1.1 RELATED DOCUMENTS

- A. Drawings and general provisions of the Contract, including General and Supplementary Conditions and Division 01 Specification Sections, apply to this Section.

1.2 SUMMARY

- A. Section Includes: Gypsum board shaft wall assemblies.

1.3 ACTION SUBMITTALS

- A. Product Data: For each component of gypsum board shaft wall assembly.

1.4 INFORMATIONAL SUBMITTALS

- A. Evaluation Reports: For shaft wall assemblies firestop tracks, from ICC-ES.

1.5 DELIVERY, STORAGE, AND HANDLING

- A. Store materials inside under cover and keep them dry and protected against weather, condensation, direct sunlight, construction traffic, and other potential causes of damage. Stack panels flat and supported on risers on a flat platform to prevent sagging.

1.6 FIELD CONDITIONS

- A. Environmental Limitations: Comply with ASTM C 840 requirements or with gypsum board manufacturer's written recommendations, whichever are more stringent.
- B. Do not install interior products until installation areas are enclosed and conditioned.
- C. Do not install panels that are wet, moisture damaged, or mold damaged.
 - 1. Indications that panels are wet or moisture damaged include, but are not limited to, discoloration, sagging, and irregular shape.
 - 2. Indications that panels are mold damaged include, but are not limited to, fuzzy or splotchy surface contamination and discoloration.

PART 2 - PRODUCTS

2.1 PERFORMANCE REQUIREMENTS

- A. Fire-Resistance-Rated Assemblies: For fire-resistance-rated assemblies, provide materials and construction identical to those tested in assembly indicated according to ASTM E 119 by an independent testing agency.

2.2 GYPSUM BOARD SHAFT WALL ASSEMBLIES

- A. Fire-Resistance Rating: 1 hour.
- B. Studs: Manufacturer's standard profile for repetitive members, corner and end members, and fire-resistance-rated assembly indicated.
 - 1. Depth: 2-1/2 inches.
 - 2. Minimum Base-Metal Thickness: 0.018 inch.
- C. Runner Tracks: Manufacturer's standard J-profile track with manufacturer's standard long-leg length, but at least 2 inches long and matching studs in depth.
 - 1. Minimum Base-Metal Thickness: 0.018 inch.
- D. Firestop Tracks: Provide firestop track at head of shaft wall on each floor level.
- E. Room-Side Finish: Gypsum board, type X.
- F. Shaft-Side Finish: Gypsum shaftliner board, Type X.
- G. Insulation: Sound attenuation blankets.

2.3 PANEL PRODUCTS

- A. Regional Materials: Gypsum panel products shall be manufactured within 500 miles of Project site.
- B. Panel Size: Provide in maximum lengths and widths available that will minimize joints in each area and that correspond with support system indicated.
- C. Gypsum Shaftliner Board, Type X: ASTM C 1396/C 1396M; manufacturer's proprietary fire-resistive liner panels with paper faces.
 - 1. Thickness: 1 inch.
 - 2. Long Edges: Double bevel.
- D. Gypsum Board: As specified in Section 09250 "Gypsum Drywall".

2.4 NON-LOAD-BEARING STEEL FRAMING

- A. Steel Framing Members: Comply with ASTM C 645 requirements for metal unless otherwise indicated.
 - 1. Protective Coating: Coating with equivalent corrosion resistance of ASTM A 653/A 653M, G40 unless otherwise indicated.
- B. Firestop Tracks: Top runner manufactured to allow partition heads to expand and contract with movement of the structure while maintaining continuity of fire-resistance-rated assembly indicated; in thickness not less than indicated for studs and in width to accommodate depth of studs.

2.5 AUXILIARY MATERIALS

- A. General: Provide auxiliary materials that comply with manufacturer's written recommendations.
- B. Trim Accessories: Cornerbead, edge trim, and control joints of material and shapes as specified in Section 09250 "Gypsum Drywall" that comply with gypsum board shaft wall assembly manufacturer's written recommendations for application indicated.
- C. Steel Drill Screws: ASTM C 1002 unless otherwise indicated.
- D. Track Fasteners: Power-driven fasteners of size and material required to withstand loading conditions imposed on shaft wall assemblies without exceeding allowable design stress of track, fasteners, or structural substrates in which anchors are embedded.
 - 1. Expansion Anchors: Fabricated from corrosion-resistant materials, with capability to sustain, without failure, a load equal to 5 times design load, as determined by testing according to ASTM E 488 conducted by a qualified testing agency.
 - 2. Power-Actuated Anchors: Fastener system of type suitable for application indicated, fabricated from corrosion-resistant materials, with capability to sustain, without failure, a load equal to 10 times design load, as determined by testing according to ASTM E 1190 conducted by a qualified testing agency.
- E. Sound Attenuation Blankets: As specified in Section 09250 "Gypsum Drywall".

PART 3 - EXECUTION

3.1 EXAMINATION

- A. Examine substrates to which gypsum board shaft wall assemblies attach or abut, with Installer present, including hollow-metal frames, cast-in anchors, and structural framing. Examine for compliance with requirements for installation tolerances and other conditions affecting performance.
- B. Examine panels before installation. Reject panels that are wet, moisture damaged, or mold damaged.

- C. Proceed with installation only after unsatisfactory conditions have been corrected.

3.2 INSTALLATION

- A. General: Install gypsum board shaft wall assemblies to comply with requirements of fire-resistance-rated assemblies indicated, manufacturer's written installation instructions, and ASTM C 754 other than stud-spacing requirements.
- B. Do not bridge building expansion joints with shaft wall assemblies; frame both sides of expansion joints with furring and other support.
- C. Install supplementary framing in gypsum board shaft wall assemblies around openings and as required for blocking, bracing, and support of gravity and pullout loads of fixtures, equipment, services, heavy trim, furnishings, wall-mounted door stops, and similar items that cannot be supported directly by shaft wall assembly framing.
- D. Penetrations: At penetrations in shaft wall, maintain fire-resistance rating of shaft wall assembly by installing supplementary steel framing around perimeter of penetration and fire protection behind boxes containing wiring devices, elevator call buttons, elevator floor indicators, and similar items.
- E. Isolate perimeter of gypsum panels from building structure to prevent cracking of panels, while maintaining continuity of fire-rated construction.
- F. Firestop Tracks: Where indicated, install to maintain continuity of fire-resistance-rated assembly indicated.
- G. Control Joints: Install control joints according to ASTM C 840 and in specific locations approved by Architect while maintaining fire-resistance rating of gypsum board shaft wall assemblies.
- H. Installation Tolerance: Install each framing member so fastening surfaces vary not more than 1/8 inch from the plane formed by faces of adjacent framing.

3.3 PROTECTION

- A. Protect installed products from damage from weather, condensation, direct sunlight, construction, and other causes during remainder of the construction period.
- B. Remove and replace panels that are wet, moisture damaged, or mold damaged.
 - 1. Indications that panels are wet or moisture damaged include, but are not limited to, discoloration, sagging, and irregular shape.
 - 2. Indications that panels are mold damaged include, but are not limited to, fuzzy or splotchy surface contamination and discoloration.

END OF SECTION

SECTION 09250

GYPSUM DRYWALL

PART 1 - GENERAL

1.01 RELATED DOCUMENTS

- A. Examine Drawings, Contract Conditions all other Sections of the Specifications for requirements which affect work of this Section whether or not such work is specifically mentioned in this Section.
- B. Coordinate work with that of all other trades affecting, or affected by work of this Section. Cooperate with such trades to assure the steady progress of all Project work.

1.02 DESCRIPTION

- A. This section provides minimum standards for gypsum drywall work. The work required consists of furnishing all materials, equipment, accessories, labor and supervision, and performing all operations necessary to provide finished gypsum drywall work as shown on the Drawings, as specified herein, and as is additionally required to properly complete the work.
- B. Without in any way limiting the work to be performed, the following gypsum drywall work items are mentioned:
 - 1. Gypsum board and metal furring over concrete masonry units.
 - 2. Gypsum board and metal drywall framing for partitions and fire rated ceilings.
 - 3. Drywall finishing of gypsum boards (joint tape-and-compound treatment).
 - 4. Ceiling access doors.
 - 5. Cement backer panels for ceramic tile.

1.03 QUALITY ASSURANCE

- A. Gypsum Board Standard: GA-216 by Gypsum Association.
- B. Metal Support Standard: ASTM C 754.
- C. Manufacturer: Obtain gypsum board products and accessories from a single manufacturer, or from manufacturers recommended by the manufacturer of gypsum boards.
- D. Allowable Tolerances: 1/16" offsets between planes of board faces, and 1/8" in 8'-0" for plumb, level, warp and bow.

1.04 SUBMITTALS

Submit manufacturer's product specifications and installation instructions for each gypsum drywall material (i.e., gypsum board, furring, etc.), component, including other data as may be required to show compliance with these specifications.

1.05 PRODUCT HANDLING

Deliver, identify, store and protect gypsum drywall materials to comply with Gypsum Association Specification GA-216.

PART 2 - MATERIALS

2.01 ACCEPTABLE MANUFACTURERS

Subject to compliance with requirements, manufacturers offering products which may be incorporated in the work are listed in the following paragraphs.

2.02 METAL SUPPORT MATERIALS

- A. Furring Members: ASTM C 645; 20 gage, hat-shaped (C-shaped studs in some locations).
- B. Studs: ASTM C 645; 20 gage unless otherwise indicated. Studs, runners and accessories in or abutting exterior walls shall be galvanized; otherwise primed. Studs shall be 3-5/8" except as otherwise indicated. Studs at designated plumbing walls shall be 6". Runners shall be the type recommended by stud manufacturer for floor and ceiling support of studs, and for abutment of drywall work at other work. Provide stud manufacturer's standard clips, ties, reinforcements, fasteners, grommets, and other accessories as needed for a complete stud system.
- C. Fasteners: Type and size recommended by furring manufacturer for the substrate and application indicated.
- D. Manufacturers: Provide materials by one of the following firms:

Allied Structural Industries
Dale Industries, Inc.
United States Gypsum Co.

2.03 GYPSUM DRYWALL

- A. Gypsum Drywall and Related Products:

Provide materials by one of the following firms:

The Flintkote Company
Gold Bond Building Products Div., National Gypsum Co.
United States Gypsum Co.
Georgia-Pacific

- B. Exposed Gypsum Drywall: Regular type with tapered long edges.

Thickness: Provide gypsum drywall of the thicknesses indicated on the Drawings. Where not indicated, comply with thickness requirements of GA-216 for each application and support spacing. Comply with requirements for indicated fire-resistance ratings.

Sheet Size: Maximum length available which will minimize end joints.

Insulating Type: Provide in all exterior walls (aluminum foil backing).

Type WR: Provide in Toilet and Storage.

Type X: Provide at Fire Rated assemblies and as indicated.

- C. Cement Backer Panels for Ceramic Tile: Provide Durock brand by United States Gypsum Company.

2.04 TRIM ACCESSORIES

Provide manufacturer's standard trim accessories of types indicated for drywall work, formed of galvanized steel unless otherwise indicated, with either knurled and perforated or expanded flanges for nailing and beaded for concealment of flanges in joint compound. Provide corner beads, L-type edge trim-beads, U-type edge trim-beads, special L-kerf-type edge trim-beads, and one-piece control joint beads.

2.05 JOINT TREATMENT MATERIALS

- A. ASTM C 475; type recommended by the manufacturer for the application indicated, except as otherwise noted.
- B. Joint Tape: Perforated or plain type.
- C. Joint Compound: Provide chemical-hardening-type for bedding and filling, ready-mixed vinyl-type or vinyl-type powder for topping.

2.06 MISCELLANEOUS MATERIALS

- A. Provide auxiliary materials for gypsum drywall work of the type and grade recommended by the gypsum board manufacturer.
- B. Gypsum Drywall Fasteners: Comply with GA-216.

2.07 ACCESS DOORS

Ceiling hatch shall be 2-hour fire rated (2'-0" X 2'-6") with 16 gauge galvanized steel frame and 20 gauge galvanized steel upward acting door. Door shall be insulated with 1 inch mineral wool insulation. Door shall be equipped with a spring lever, as manufactured by the Bilco Co., Cedrex/Intertek, or approved equal.

PART 3 - EXECUTION

3.01 PREPARATION FOR METAL SUPPORT SYSTEMS

- A. Coordinate work of this section with other work to ensure that all inserts and other items have been provided for.
- B. Furnish concrete inserts, clips and similar devices to other trades for installation well in advance of time needed for such other work.

3.02 INSTALLATION OF METAL SUPPORT SYSTEMS

- A. Do not bridge building expansion joints with furring system; frame both sides of joints with furring.
- B. Space wall furring members 16" o.c., except as otherwise indicated.
- C. Install supplementary framing, runners, furring, blocking and bracing at openings and terminations in the work, and at locations required to support fixtures, equipment, services, heavy trim, furnishings and similar work which cannot be adequately supported directly on gypsum drywall alone.

3.03 GENERAL GYPSUM DRYWALL INSTALLATION REQUIREMENTS

- A. Pre-Installation Conference: Meet at the Project site with the installers of related work and review the coordination and sequencing of work to ensure that all work to be concealed by gypsum drywall has been accomplished and approved.
- B. Locate exposed end-butt joints as far from center of walls as possible, and stagger not less than 1'-0" in alternate courses of drywall.
- C. Install drywall boards vertically to avoid end-butt joints wherever possible.
- D. Install exposed gypsum drywall board with face side out. Do not install imperfect, damaged or damp boards. Butt boards together for a light contact at edges and ends with not more than 1/16" open space between boards. Do not force into place.
- E. Locate edge joints over supports. Position boards so that tapered edges abut, and mill-cut or field-cut ends abut. Do not place tapered edges against cut edges or ends.

- F. Attach gypsum drywall to framing and blocking as required for additional support at openings and cutouts.
- G. Form control joints and expansion joints with space between edges of boards, prepared to receive trim accessories.

3.04 METHOD OF GYPSUM DRYWALL APPLICATION

Apply gypsum boards to supports with recommended screws. Follow the manufacturer's recommendations for single layer applications.

3.05 INSTALLATION OF DRYWALL TRIM ACCESSORIES

- A. Where feasible, use the same fasteners to anchor trim accessory flanges as required to fasten gypsum board to supports. Otherwise, fasten flanges by screwing in accordance with manufacturer's instructions and recommendations.
- B. Install metal corner beads at external corners of drywall work.
- C. Install metal edge trim whenever edge of gypsum board would otherwise be exposed or semi-exposed. Provide type with face flange to receive joint compound. Install L-type trim where work is tightly abutted to other work, and install special kerf-type where other work is kerfed to receive long leg of L-type trim. Install U-type where edge is exposed, revealed, gasketed, or sealant-filled.
- D. Install metal control joint (beaded-type) where indicated.

3.06 ACCESS DOORS

Install access doors in the locations shown, in strict accordance with the manufacturer's instructions and recommendations.

3.07 DRYWALL FINISHING

- A. Apply drywall treatment at gypsum board joints (both directions), flanges of trim accessories, penetrations, fastener heads, surface defects and elsewhere as required to prepare work for subsequent application of finishes. Prefill open joints and tapered edges, using type of compound recommended by manufacturer.
- B. Apply joint tape at joints between gypsum boards, except where a trim accessory is indicated or required.
- C. Apply joint compound in 3 coats (not including prefill of openings in base), and sand between coats and after last coat.
- D. Drywall finishing shall be performed so that all joints, fastener locations, trim flanges, etc., are indiscernible after painting.
- E. Refer to Section 09900 for painting finishes to be applied to drywall work.

3.08 PROTECTION OF WORK

Protect gypsum drywall work from damage and deterioration during the entire construction period.

END OF SECTION

SECTION 09300

CERAMIC TILE

PART 1 - GENERAL

1.01 RELATED DOCUMENTS

- A. Examine Drawings, Contract Conditions all other Sections of the Specifications for requirements which affect work of this Section whether or not such work is specifically mentioned in this Section.
- B. Coordinate work with that of all other trades affecting, or affected by work of this Section. Cooperate with such trades to assure the steady progress of all Project work.

1.02 DESCRIPTION

The work in this section consists of furnishing all materials, equipment, supplies, transportation, labor and supervision, and performing all operations required to install all ceramic tile work as shown on the Drawings and schedules, as specified herein, and as is additionally required to properly complete the work.

1.03 SPECIFIED ELSEWHERE

- A. Cement backer board for ceramic tile - Section 09250
- B. Grab bars and bath accessories - Section 10600

1.04 GENERAL REQUIREMENTS

- A. Ceramic mosaic floor tiles over concrete and glazed ceramic wall tiles over gypsum board shall be manufactured by American Olean Tile Co., United States Ceramic Tile Co., or Dal-Tile.
- B. Deliver all materials to the site in manufacturers' unopened containers with grade seals unbroken and labels intact; keep tile cartons dry.
- C. Maintain temperature at 50°F. minimum during tile work and for 7 days after completion.
- D. All work shall be installed in strict accordance with the requirements of the latest revision of the Tile Council of America (TCA), "Handbook for Ceramic Tile Installation".

1.05 SUBMITTALS

- A. The Contractor shall submit samples of the tiles to the Resident for selection and approval.

- B. Submit eight (8) copies of manufacturers' specifications and installation instructions for each material required.

PART 2 - MATERIALS

2.01 CERAMIC FLOOR TILE

- A. Tile shall be "Ayers Rock" by Daltile. Tile shall be colorbody, impervious porcelain type, 5/16 inch thick. Tile shall be standard colors, all as selected from samples submitted to the Architect. Tile size shall be 13" x 13".
- B. Tile shall be standard grade conforming to ANSI A137.1.

2.02 GLAZED CERAMIC WALL TILE

- A. Tile shall be "Unity" by Daltile. Tile shall be polished colorbody impervious porcelain type, 5/16 inch thick. Tile shall be standard colors, all as selected from samples submitted to the Architect. Tile size shall be 12" x 24". Base shall be matching cove type in 6" x 12" pieces. Top Bullnose shall be 3" x 12" pieces. All outside corners (wall and base) shall have standard Cove Base Outcorner trim. Provide all shapes required to meet conditions, such as inside corners, caps, etc.
- B. Tile and base shall be standard grade conforming to ANSI A137.1.

2.03 DRY SET MORTAR

Dry set mortar shall conform to ANSI A118.1.

2.04 GROUTING MATERIAL

Grouting material shall conform to ANSI A118.6. Color of grout for walls and floors shall be selected by the Architect. Grout shall have integral sealer component.

2.05 SEALANT

Sealant shall be #784 white silicone as manufacturer by Dow Corning Co. Similar sealant by General Electric may be submitted for the Engineer's approval.

PART 3 - EXECUTION

3.01 INSTALLATION

- A. Before tiling, be sure variations of surface to be tiled is not more than 1/8 inch in 8 feet for walls and 1/8 inch in 10 feet for floors and that all plumbing fixtures, fittings and

connections are in place and surfaces are free of curing membranes, oil, grease, wax and dust.

- B. Tile applied shall be properly spaced, and set true, plumb and straight.
- C. Cove tile base shall be laid with internal and external corners. Cove shall match the level of the floor so there is a smooth transition between wall and floor.
- D. Ceramic tile shall be set with dry set mortar conforming to ANSI A108.5.
 - 1. Floor: TCA Method F113.
 - 2. Wall: TCA Method W202.
- E. Grout shall be placed and thoroughly worked in to all tile joints to form a smooth dense surface free of voids. Clean all tile surfaces with water as soon as grout becomes firm.
- F. Where tile abuts steel, wood or other material, seal the joint with sealant.
- G. It will be the responsibility of the tile contractor to protect the work in this section and the work of others from damage resulting from this work. Damaged items shall be refinished, replaced or repaired, as determined by the Engineer, at no additional cost.
- H. Cover tile completely with heavy reinforced non-staining sisal kraft paper, lapped a minimum of three inches, with joints sealed and taped. No traffic shall be allowed on tile floor for at least three days after installation.

END OF SECTION

SECTION 09500

SUSPENDED CEILINGS

PART 1 – GENERAL

1.1 RELATED DOCUMENTS

- A. Examine Drawings, Contract Conditions all other Sections of the Specifications for requirements which affect work of this Section whether or not such work is specifically mentioned in this Section.
- B. Coordinate work with that of all other trades affecting, or affected by work of this Section. Cooperate with such trades to assure the steady progress of all Project work.

1.2 DESCRIPTION

The work in this section consists of furnishing all materials, equipment, supplies, incidentals, labor and supervision, and performing all operations required to furnish and install all lay-in suspended ceiling components as shown on the schedules and Drawings, and as specified herein and as is additionally required to properly complete the work.

1.3 GENERAL REQUIREMENTS

- A. All ceilings shall be installed in accordance with the approved instructions of the manufacturer of the suspension system and ceiling panels.
- B. All overhead mechanical and electrical work, excluding surface mounted equipment, shall be completed and in-place prior to the installation of the ceilings.
- C. Installation of lay-in ceiling panels shall not begin until residual moisture from concrete and masonry work has dissipated. Before installation, the building shall be enclosed and permanent heating equipment in operation.

1.4 SUBMITTALS

- A. One linear foot of main runner, cross tee, edge molding and hanger wire.
- B. One square foot of panel.
- C. Shop drawings shall be submitted and approval obtained prior to delivery of ceiling system components to the site. Drawings shall clearly delineate all components of the system and shall show proposed layout of ceiling grid.
- D. Submit manufacturer's product data for all materials.

PART 2 - MATERIALS

2.1 MATERIALS

- A. All materials shall be delivered in their original unopened packages.
- B. Hanger wires shall be galvanized carbon steel, ASTM A 641, soft temper, prestraightened, prestretched, yield-stress load of at least 3 times design load but not less than 12 gage. Wire coils will not be permitted.
- C. Ceiling panels shall be 24" x 48" x 3/4" thick regular lay-in type commercial ceiling tile "Dune Second Look II (2712) by Armstrong World Industries, conforming to Class A (Fed. Spec. SS-S-118B) flame spread rating.
- D. Suspension system shall be an exposed interlocking grid assembly complying with ASTM C 635, Standard Specification for Metal Suspension Systems for "Acoustical Lay-in Panel Ceilings." Suspension system shall be classified heavy duty. Exposed members shall have a factory applied low gloss white baked enamel finish. System shall be "Prelude ML" by Armstrong World Industries or approved equal.

PART 3 - EXECUTION

3.1 INSTALLATION

- A. Installation shall be in accordance with ASTM Recommended Practice C 636. Grid system shall be true, straight and level to a tolerance of one in 1000, with border units of the greatest possible size. Install hangers directly to supporting structure. All members and panels shall be installed in strict accordance with the manufacturer's recommendations. All joints around electric outlets, ducts, pipes and other work extending through the ceiling treatment shall be sealed tight with Engineer approved nonhardening caulking compound. At completion of the ceiling treatment, joints in grid shall be straight and true-to-line, with exposed surfaces flush and level with hairline joints. Units shall be neatly jointed to connecting work. Provide angles at intersections of all vertical surfaces.
- B. Following erection, dirty and discolored surfaces of acoustical units and/or support system shall be cleaned in accordance with the manufacturer's recommendations and left free from defects. Grid components and acoustical tiles that are damaged in any way or improperly installed shall be removed and replaced as directed, at no additional cost.

END OF SECTION

SECTION 09650RESILIENT WALL BASE AND ACCESSORIES

PART 1 - GENERAL

1.01 RELATED DOCUMENTS

- A. Examine Drawings, Contract Conditions all other Sections of the Specifications for requirements which affect work of this Section whether or not such work is specifically mentioned in this Section.
- B. Coordinate work with that of all other trades affecting, or affected by work of this Section. Cooperate with such trades to assure the steady progress of all Project work.

1.02 DESCRIPTION

The work includes furnishing all materials, equipment, supplies, labor and supervision, and performing all operations required to provide resilient accessories as shown on the Drawings, as specified herein and as is additionally required to properly complete the work. Location of wall base and accessories are shown or scheduled on the Drawings.

1.03 QUALITY ASSURANCE

Provide each type of resilient accessory as produced by a single manufacturer, and include manufacturers' recommended primers, adhesives, sealants, leveling compounds, etc.

1.04 SUBMITTALS

- A. Product Data: Submit 8 copies of manufacturer's technical data and installation instructions for each type of resilient wall base, accessory, and installation materials such as adhesive, leveling compound, etc.
- B. Samples: Submit samples of each type, color, and pattern of resilient wall base, and accessory required, indicating full range of color and pattern variations. Provide 6" long sections of wall base and accessories.

For initial selection of colors and patterns submit, prior to above, samples in form of actual sections of resilient wall base and accessory, showing full range of colors and patterns available for each.

- C. Certification for Fire Test Performance: Submit manufacturer's certification that resilient wall base and accessories furnished comply with required fire test performance and have been tested and meets indicated standards.
- D. Maintenance Instructions: Submit 8 copies of manufacturer's recommended maintenance practices for each type of resilient wall base and accessory required.

1.05 JOB CONDITIONS

Maintain minimum temperature of 65°F (18°C) in spaces to receive resilient wall base and accessories for at least 48 hours prior to installation, during installation, and for not less than 48 hours after installation. Store materials in spaces where they will be installed for at least 48 hours before beginning installation. Subsequently, maintain minimum temperature of 55°F (13°C) in areas where work is completed.

Where possible, install resilient wall base and accessories after other finishing operations, such as painting, have been completed.

1.06 MAINTENANCE STOCK

A. Provide Owner will all non-installed undamaged product in original packaging at the completion of the work

PART 2 - PRODUCTS

2.01 ACCEPTABLE MANUFACTURERS

Subject to compliance with requirements, provide products of one of the following manufacturers:

Armstrong Company, Floor Division
Azrock Industries, Inc., Floor Division
Burke Industries Inc.
Flexco
Johnsonite; a Tarkett Company
Kentile Floors, Inc.
Roppe Corporation, USA
VPI Corporation

2.02 MATERIALS

- A. Colors and Patterns: As selected by the Architect from the manufacturer's standards.
- B. Vinyl Wall Base: Standard straight base 1/8 inch thick by 4 inches high, with preformed or molded corner units, equal to Kentile VC-100 matte finish.
- C. Rubber Stair Treads: Type TS or TP, Class 2 pattern (embossed, grooved, or ribbed); Group 1 (imbedded abrasive strips); Round nosing (1-1/2 inch minimum height); 1/4" minimum thickness and tapered to back edge.
- D. Adhesives (Cements): Waterproof stabilized type as recommended by resilient materials manufacturers to suit material and substrate conditions.

PART 3 - EXECUTION

3.01 PREPARATION

- A. Broom clean or vacuum surfaces to be covered and inspect subfloor. Start of installation indicates acceptance of conditions and full responsibility for completed work.

3.03 INSTALLATION OF WALL BASE AND ACCESSORIES

- A. Apply vinyl wall base to walls, casework and other permanent fixtures and vertical surfaces in rooms or areas where base is required, including closets. Install base in lengths as long as practicable, with preformed or molded corner units. Tightly bond base to substrate throughout length of each piece, with continuous contact at horizontal and vertical surfaces.
- B. Apply rubber stair treads and nosings full width of each tread and in accordance with the manufacturer's instructions. Install manufacturer's two-part epoxy compound recommended by stair tread manufacturer to fill nosings that do not conform to stair tread contours.

3.04 CLEANING AND PROTECTION

- A. Remove excess adhesive and other surface blemishes using neutral type cleaners as recommended by manufacturer.
- B. Finishing: After completion of the work, just prior to inspection of the work for Substantial Completion, thoroughly clean floors, wall base and accessories.

END OF SECTION

SECTION 09900PAINTING

PART 1 - GENERAL

1.1 RELATED DOCUMENTS

- A. Examine Drawings, Contract Conditions all other Sections of the Specifications for requirements which affect work of this Section whether or not such work is specifically mentioned in this Section.
- B. Coordinate work with that of all other trades affecting, or affected by work of this Section. Cooperate with such trades to assure the steady progress of all Project work.

1.2 DESCRIPTION

- A. The work includes furnishing all materials, equipment, tools, supplies, transportation, staging, drop cloths, wet-paint signs, labor and supervision, etc., and performing all operations required for interior and exterior "on site" painting as noted on the Drawings, as described herein, and as is additionally required to properly complete the work.
- B. Unless otherwise indicated in the Paint Schedule, prepare surfaces and apply the number of coats scheduled herein regardless of shop or field coats specified elsewhere. Surface preparation and touch-up of shop coats is included in the work.
- C. In general, it is intended that all non-shop finished exposed surfaces throughout the interior and exterior of the building be painted as described herein and as indicated on the Drawings.
 - 1. Except as otherwise noted or directed by the Architect, the following are not to be painted: bronze; stainless steel; aluminum and other non-ferrous metals; pre-finished metals; concrete sidewalks; finish hardware; glass and glazing materials; acoustical ceilings; resilient floor/wall coverings and base; plastic laminate; lighting units and pipes, ducts, conduit, insulation, etc., in mechanical rooms except where they abut surfaces scheduled to be painted.
 - 2. Except as otherwise noted, paint all steel doors, steel door and louver frames; exposed structural steel and miscellaneous metals, interior and exterior; gypsum board walls; exposed concrete masonry units; exposed interior concrete; standing and running trim; shelving and drawers in casework; exposed rough carpentry work (e.g., plywood, back-up panels etc.); all exterior woodwork; back-priming all exterior woodwork; piping/conduit, hangers, supports, and related equipment and accessories in areas designated to be finish painted (except where finish painted by the manufacturer or specifically excluded by this specification, the Drawings or the Architect).

- D. The Contractor shall perform all work in accordance with this Specification Section and shall complete all incidental details, whether or not such details are specified herein, as is required to produce thoroughly finish painted work of the best quality.

PART 2 - PRODUCTS

2.1 MATERIALS

- A. All paints and associated materials shall be first quality products manufactured by the following companies:

Benjamin Moore
Devoe
Tnemec Company, Inc.
Sherwin Williams

- B. Insofar as possible, paints used for this Contract shall be produced by a single manufacturer.
- C. All materials used in the work are to be of the best of their brand or class, brought to the site in original unopened containers. Containers of materials must have original labels intact in order to be accepted for use on the Project. Driers, thinners and solvents shall be as recommended by the manufacturer of the paint being used.
- D. No claim as to the unsuitability of any material used will be considered unless such claim is made in writing before the materials are approved by the Resident. By submitting a product for approval, the Contractor assumes complete responsibility for the suitability of the paint and for the results obtained therewith.
- E. The Schedule of Painting listed herein designates specific manufacturers to denote the standard of quality and the type of finish desired. Materials of other manufacturers listed above shall be submitted to the Engineer for approval prior to purchase of any materials. Requests for substitution shall list the material specified and the specific material being offered as a substitute, including appropriate supportive technical data.

2.2 COLORS AND FINISHES

- A. All colors and finishes shall be as selected and/or scheduled by the Architect. Prepare for approval by the Architect, two (2) panels for each color and finish selected (i.e., semi-gloss, flat, etc.). Submit these samples at least 3 weeks in advance of the date scheduled for beginning painting work.
- B. Panels shall be at least 12 inches by 12 inches.
- C. Approved samples shall be kept in the Contractor's field office for reference for the duration of the painting work.

2.3 GENERAL REQUIREMENTS

- A. Inspect all surfaces requiring painter's finish and remedy all remaining defects.
- B. All surfaces to be painted shall receive a prime coat and two finish coats, unless otherwise noted.
- C. Take adequate precautions for protection against soiling and damage to adjacent equipment, structures, and surfaces. Protect floors, paved areas and all other adjacent surfaces against spatter and spillage. Leave and maintain protection in place until all final painting has been performed and approved in the affected area.
- D. Erect, maintain and dismantle scaffolding and access equipment without damage to structures, machinery, pipes, etc.
- E. Store rags, cleaning cloths, and waste materials smeared or contaminated with paint, oils, solvents, and other flammable materials in approved covered metal containers and remove them from buildings and dispose of them off-site after each shift and as otherwise directed by the Resident.
- F. Take precautions so that surface preparation, including dust blow-off, does not do any damage. With the approval of the Resident, equipment, machinery and items that could be damaged by grit and dust may be masked and sealed dust-tight in a suitable manner. Take precautions so that grit and dust does not fall on surfaces ready for painting or onto newly painted surfaces.
- G. As necessary, remove solvent and paint fumes by suitable means.
- H. Do not perform spray painting in areas where welding is in progress nor near operations involving open flames, sparks or high heat.
- I. Do not perform painting near or on energized electrical equipment or rotating equipment without proper precautions being taken nor until approval to proceed is received from the Engineer.
- J. Take all necessary precautions to ensure that paint is not introduced into working parts of equipment, machinery, filters, motors, controls, etc. Where the indicated application method may cause damage, notify the Resident so that the Resident and manufacturer can agree on an alternate method of application.
- K. Mask and otherwise protect nameplates, gauges, glass, fire rating labels, instructions, lubrication fittings, instruments and similar items as necessary to retain their original conditions after completion of the painting work. Remove protection after painting is completed.
- L. Follow the manufacturers' recommendations and OSHA regulations regarding precautions and protective clothing and equipment to be used by painters.

- M. Adequately provide for the proper electric and static grounding of spray equipment, of items being painted and other static-producing equipment and electrical tools. The motors on painting and coating related equipment shall be explosion proof. Supply all ventilation equipment, respirators, safety lines, and eye, face, head and body protection.
- N. The Contractor shall be responsible for all damage done to other work and for repairing same to the satisfaction of the Engineer. Replace all materials damaged to such an extent that they cannot be restored to their original condition. This work shall be done at the Contractor's expense.

2.4 SUBMITTALS

Submit 8 copies of the manufacturers' technical information including paint label analysis and application instructions for each material proposed for use.

2.5 DELIVERY AND STORAGE

- A. Deliver all materials to the jobsite in original, new and unopened packages and containers bearing the manufacturer's name and label. Technical data sheets covering use of the product shall be included with every consignment delivered. Each container shall bear the label of the manufacturer and be clearly marked in a durable manner to show the following information:
 - 1. Type of paint by generic description.
 - 2. Manufacturer's paint name and reference number.
 - 3. Gross and net weights and/or volumes.
 - 4. Date of manufacture and shelf-life.
 - 5. Recommended thinner and mix ratios.
 - 6. Recommended safety precautions and antidotes in case of contact or ingestion.
- B. Store materials in an enclosed, protected storage area with provisions for maintaining the materials in storage at not less than 60°F nor more than 95°F unless more restrictive temperatures are required by the paint manufacturer to guarantee shelf-life. Provide adequate ventilation in storage areas. No paint stored longer than the manufacturer's specified shelf-life shall be used in the work. Keep the storage space neat and clean and repair all damage to the space and surroundings.

PART 3 - EXECUTION

3.01 APPLICATION CONDITIONS

- A. Apply water-base paints only when the temperature of the surface to be painted and the surrounding air temperature is between 50°F and 90°F., unless otherwise permitted by the paint manufacturers' printed instructions.
- B. Apply solvent thinned paints only when the temperature of the surface to be painted and the surrounding air temperature is between 45° and 95°F., unless otherwise permitted by the paint manufacturers' printed instructions.
- C. Do not apply paint in snow, rain, fog or mist, or when the relative humidity exceeds 85%. Do not apply paint to damp or wet surfaces nor when the temperature of the surface to be painted is lower than the corresponding wet-bulb temperature for the existing air temperature and relative humidity, unless otherwise permitted by the paint manufacturers' printed instructions.
- D. Continue painting during inclement weather only if the areas and surfaces to be painted are enclosed and maintained within the temperature and humidity limits specified by the paint manufacturer during both the application and drying periods.
- E. Do not perform exterior painting when windblown dust or debris may contaminate the work. Isolate interior painting areas as required to prevent dust circulation. Provide temporary closures where isolation cannot be effected by closing doors and windows.
- F. Prepare trial coats as requested by the Resident for coats differing in color, shade, application method, etc.
- G. Each coat of paint must be dry before the succeeding coat is applied or any surface preparation (i.e., sandpapering) is done.
- H. Perform painting and finishing in the best and most workmanlike manner known to the trade. No paint shall be applied by other than skilled workmen. All surfaces are to be left smooth, even and free from brush marks and visible paint laps. If surfaces are not thoroughly covered, apply additional coats or otherwise remedy problems until finished surfaces are of an acceptable uniform color, texture and sheen, at no additional cost.
- I. Provide specified and approved finish coats which are compatible with prime paints. Review other sections of these specifications in which prime paints are to be provided to ensure compatibility of total coating system for various substrates. Upon request from other trades, furnish information on the characteristics of finish materials proposed for use to ensure that compatible prime coats are used. Provide barrier coats over incompatible primers or remove primer and reprime as required. Notify the Resident in writing of any anticipated problems using the specified coating systems over substrates primed by others.

- J. If a prime coat does not dry to a uniform sheen over the entire surface, spot prime the areas that indicate suction before applying the finish coat.
- K. After the first coat is applied, if the surface is not smooth, sand and refinish it.
- L. Maintain a record, in a form approved by the Resident, of all painting work performed. Indicate on the record the locations and types of surfaces painted, manufacturers' stock numbers, color numbers, quantity of each paint type applied, surface preparation, and the number and mil thickness of each coat applied.

3.02 INSPECTION

- A. Examine the areas and conditions under which painting work is to be applied and notify the Resident in writing of conditions detrimental to the proper and timely completion of the work. Do not proceed with the work until unsatisfactory conditions have been corrected.
- B. Commencement of painting work will be construed as the Contractor's acceptance of the surfaces and conditions within that particular area.

3.03 SURFACE PREPARATION

A. General:

1. Perform surface preparation and cleaning procedures in strict accordance with the paint manufacturers' instructions and recommendations, and as is additionally specified herein.
2. Thoroughly inspect, clean and repair all surfaces which have received a shop coat of paint under other sections of the specifications prior to application of additional coats. Where shop primer has been damaged, the field painting work includes surface preparation and touch-up painting of abraded and otherwise defective primer, as well as priming of uncoated field welds, field bolting, and all other bare surfaces before application of the first field coat. Feather edges of sound primer into defective prime areas, bare field welds, etc., and apply touch-up paint to overlap the adjacent sound primer by at least 2 inches.
3. Provide non-damaging protection for all hardware, hardware accessories, machined surfaces, plates, and similar items in place which are not to be finish painted, prior to surface preparation and painting operations.
4. Clean all surfaces to be painted before applying paint or surface treatments. Remove oil and grease prior to mechanical cleaning. Schedule cleaning and painting operations so that contaminants from the cleaning process will not fall onto newly cleaned or newly painted surfaces.
5. Failure on the part of the Contractor to remedy surface imperfections that remain visible following the finish coat of paint shall be cause for rejection, solely at the

discretion of the Engineer, and shall be considered due cause for refinishing the surface area involved by the Contractor, at no additional cost.

6. Cut out and fill with spackle or other approved compounds, all scratches, cracks, abrasions, etc., adjoining trim materials. Make all patches flush with adjoining surfaces and allow to dry and then properly seal before application of the prime coat. In general, interior caulking and sealants will be installed prior to start of field painting; however, certain sealants require that painting be applied first. It shall be the Contractor's responsibility to coordinate such work with the trades involved.
- B. Specific Surface Preparation: The painting systems will indicate one or more of the following methods of surface preparation for each item or surface to be painted.
1. Solvent Cleaning: Cleaning in accordance with Steel Structures Painting Council (SSPC) Specification SP 1.
 2. Alkaline Cleaning: Wash with weak alkaline solution consisting of 1 part trisodium phosphate to 32 parts of water, rinse thoroughly with clean, potable water, and dry.
 3. Masonry and Concrete: (Concrete Block and Concrete) - remove all form oil, dust, dirt, efflorescence, chalk, loose material, laitance, etc., by wire brushing, stone rubbing and other appropriate means (use of acid cleaners must be approved by the Engineer). Comply with paint manufacturers' recommendations regarding neutralizing surface for oil base paints or wetting for water base paints. Patch all ratholes and rough spots with an Engineer approved compound. Keep patches damp (where applicable) for a period of at least 24 hours and then allow to dry thoroughly prior to application of paint. Patch in a neat and workmanlike manner. Test each patch for adhesion before painting. Do not paint new concrete and masonry for at least 28 days after placement to permit the concrete and mortar to cure and dry out sufficiently.
 4. Wood and PVC Surface: Perform alkaline cleaning to remove grease, oil, wax, etc. Remove alkali solution with water soaked wipers and then dry the surfaces. Smooth surface by fine sanding. Blunt sharp edges with light hand sanding. Seal knots and pitch streaks with shellac. For surfaces which are to receive an opaque finish, fill holes, cracks, etc., with a latex base compound and when hardened, sand smooth. In areas where the wood is to be stained, mix proper colored stain with the wood filler before application to ensure color match of the filler to surrounding woodwork. Do not apply paint or stain to unfinished wood having a moisture content of more than 10% (at a minimum 3/16 inch depth) as checked by a Painter's Moisture Register - Model 9.
 5. Ferrous Metals: Clean iron and steel surfaces that have not been previously shop coated, and which do not require sand blasting, of rust and scale in accordance with Steel Structures Painting Council Specification SP-3, Power Tool Cleaning, prior to application of prime coat. Prior to mechanical cleaning, solvent or alkaline clean surfaces to remove oil, grease, and other contaminants. Clean

surfaces the same day the surfaces are to be painted. Take special care to avoid burnishing surfaces by wire brushing.

6. Galvanized Surfaces: Solvent clean and scrub with scouring pads to remove all oil and "white rust". Follow by rinsing with clean, water soaked wipers, and then dry the surfaces. When required (i.e., prior to application of alkyd coatings), apply a "wash primer" in accordance with the paint manufacturers' recommendations.
7. Preparation for Touch-up Painting: Clean all field bolting, field welds, unprimed steel, and all other miscellaneous uncoated metal of rust, scale, welding contaminants, grease, oil and other foreign matter by alkaline and power tool cleaning. Remove all weld spatter, sharp edges and points by chipping and grinding. Remove damaged primer until sound primer is encountered. Feather the edge of paint surrounding damaged areas and overlap adjacent sound primer by at least 2 inches with touch-up primer.
8. Drywall (Gypsum Board): Prepare all drywall surfaces so that there are no cracks, holes or other physical damage present, nor any chalkiness, insufficiently slaked lime, excessively porous surfaces, crazing, joint compound fins and holidays. Do not apply any paint to plaster or drywall surfaces when the surface moisture, as measured by Painter's Moisture Register - Model 9, exceeds that allowed by the paint manufacturer.

3.04 MATERIALS PREPARATION

Mix and apply paint in compliance with the manufacturer's directions. Thoroughly stir paint materials until the ingredients therein are completely intermixed and, if necessary, strain prior to application. Do not mix any surface film into the paint. If required, use thinners furnished or recommended by the paint manufacturers for the specific materials and application conditions. Do not use thinner in excess of the manufacturer's recommendations. Proportion and prepare catalyzed paints in exact accordance with the manufacturer's directions. Make sure that personnel mixing paint are knowledgeable of the products being mixed.

3.05 APPLICATION

- A. In general, the painting systems specifications indicate the required method of application; brush, roller or spray. Where spray equipment is required, the equipment and application pressures shall conform to the paint manufacturer's recommendations, and shall be subject to acceptance by the Engineer. Where the indicated application method is not feasible or appropriate, obtain the Engineer's acceptance of an alternate method. Bring to the attention of the Engineer all discrepancies between these specifications and manufacturers' instructions and recommendations, and await the Engineer's decision of resolution before proceeding with the work in question. Where more than one method of application is given, use the method recommended by the manufacturer for the particular application.

- B. Use only tools and equipment which are suitable, clean, in good condition, and recommended by the paint manufacturer. Spray equipment shall produce proper atomization and leave a satisfactory film on the surface. Do not leave brushes and rollers to harden before cleaning. Do not use paint mitts.
- C. Apply paint as necessary to produce tough, durable and well-bonded films that will provide long-term protective performance and satisfactory appearance. Apply paint to produce a uniform thickness, free of defects such as pinholes, holidays, skips, missed areas, blistering, runs, sags, wrinkles, excessive film build-up, lack of film build-up, uneven film thickness, bubbles, cratering, cracking, crazing, poor adhesion, delamination, lifting, peeling, dry spray, overspray, excessively thinned coatings, contaminated coatings, flattening, orange peel, brush marks, solvent traps, and embedded dust and dirt.
- D. Do not apply paint to a surface that has not been properly prepared, nor when the ambient and surface conditions are not satisfactory. Do not apply paint at humidities and temperatures that will cause blistering, porosity or be otherwise detrimental to the performance and life of the paint. Provide suitable air and surface thermometers, sling psychrometers, etc., at the jobsite as are essential for the work to monitor temperature and humidity conditions.
- E. As paint application is in progress, check each coating frequently by means of suitable wet film thickness gauge to achieve the proper dry film thickness, taking in to account theoretical coverage versus actual coverage, as well as solvent loss.
- F. Strictly adhere to the manufacturers' recoat time. Do not apply paint over undercoats which have not properly cured. Conversely, adequately and properly prepare surfaces of paints which have cured past their critical recoat time. Before painting, prepare and repair undercoats deteriorated from long exposure to the weather or other adverse conditions.
- G. Use the cross-spray technique to insure uniform coverage, free of defects and missed areas. "Stripe paint" sharp edges to ensure proper build-up at the edges, prior to the application of the specified number of coats.
- H. Do not force dry paint.
- I. Protect newly painted surfaces from rain, condensation, dirt, debris, and other contamination until paint has cured.
- J. Apply additional top coats when undercoats, stains and other conditions show through the final coat. Take care to insure that all surfaces, including edges, corners, crevices, welds, exposed fasteners, etc., receive a dry film thickness equivalent to that of flat surfaces. To insure this, stripe or spot paint such areas first and then recoat as the remainder of the surface is being painted.
- K. Paint surfaces behind movable equipment and furniture the same as similar exposed surfaces.

- L. Paint interior surfaces of ducts that are visible through registers and grilles with an appropriate flat finish black paint.
- M. Paint the back and sides of access panels and removable and hinged covers to match the exposed surfaces.
- N. Finish tops and edges of exterior doors the same as the "pull" side faces.
- O. Sand lightly between coats if recommended by the manufacturer.
- P. If the dry film thickness at any of the inspection times is less than specified, apply an additional coat of the material specified, or increase the film thickness of the succeeding coat or coats, at the discretion of the Engineer, as required to ensure that the specified total dry film thickness for the finished work is obtained. Conceal all brush marks, laps, and joints between successive work days.
- Q. Scheduling Painting:
 - 1. Before applying paint, remove all dust, grit, loose rust particles, dirt, etc., from surfaces by vacuuming or blowing off with dry, oil-free air, as appropriate for the application.
 - 2. Apply paint as soon as possible after the surfaces have been cleaned, pretreated, or otherwise prepared for painting, and before subsequent surface deterioration.
 - 3. Allow sufficient time between coats to permit proper drying.

3.06 RETOUCHING

- A. Touch-up all work painted under this Contract which, for any reason, has been damaged during construction work.
- B. It is required that all finish work have acceptable surfaces when the building is ready for acceptance by the Engineer.

3.07 CLEAN-UP AND PROTECTION

- A. Upon completion of painting work, clean all paint-spattered surfaces. Remove spattered paint by approved methods, using care not to scratch or otherwise damage finished surfaces.
- B. Correct all damage caused by cleaning, repairing, replacing, and repainting, as acceptable to the Engineer.
- C. Remove temporary protective wrappings provided by others for protection of their work after completion of painting operations.

3.08 "AS-BUILT" RECORD

Submit, for record purposes, a finish paint schedule for each area and surface receiving "painter's finish", indicating actual paints applied, including manufacturer, type, gloss, color blend, etc.

3.09 GUARANTEE

Give the Authority a written guarantee that the materials and workmanship are of the highest quality and that the paint will not discolor, fade, peel, chalk, craze, chip, alligator, etc., and that any work which becomes defective within one (1) year of acceptance of the work will be promptly made good by the Contractor to the satisfaction of the Authority without cost.

3.10 PAINT SYSTEMS AND SCHEDULE

A. The following paragraphs list the various paint systems to be used for the work, and most of the major items and surfaces requiring painting. The mention of specific items and surfaces to be painted shall not be construed as limiting the total number of items and surfaces that are to be painted. The intent of this section is to have all items and surfaces painted as specified for other materials in the same environment, except for those items which are specifically excluded.

B. Systems

1. System A(1) - (Gloss Alkyd)

- a. Surface Preparation: For bare metal, alkaline clean, Power Tool Clean and solvent clean in accordance with SSPC SP-3 and SSPC-SP-1.
- b. Touch-up: Prepare damaged shop primer and galvanizing in accordance with touch-up specifications.
- c. Prime Coat: Prime touch-up areas and bare metal with Tnemec Series 4 Versare Rust Inhibitive Primer. Repair damaged galvanizing with ZRC Cold Galvanizing Compound or equal, and prime all galvanizing with Tnemec 32-1210 Tneme-Grip.
- d. Finish Coat: Two coats of Tnemec Series 2H Hi-Build Tneme-Gloss Alkyd Enamel; 2.5 to 3.5 dry mils each coat (spray, brush or roller applied).

2. System A(2) - (Semi-Gloss Alkyd)

- a. Surface Preparation: For bare metal, alkaline clean, Power Tool Clean and solvent clean in accordance with SSPC SP-3 and SSPC-SP-1.
- b. Touch-up: Prepare damaged shop primer and galvanizing in accordance with touch-up specifications.

- c. Prime Coat: Prime touch-up areas and bare metal with Benjamin Moore Retardo Rust Inhibitive Paint (163). Repair damaged galvanizing with ZRC Cold Galvanizing Compound or equal, and prime all galvanizing with Benjamin Moore Galvanized Metal Primer (155).
 - d. Finish Coats: Two (2) coats of Benjamin Moore Impervo (133) Semi-Gloss Alkyd Enamel; 1.5 dry mils for each coat (spray, brush or roller applied).
3. System B - Concrete Masonry Units (Satin Alkyd)
- a. Surface Preparation: Prepare surfaces in accordance with specifications for masonry and concrete.
 - b. Prime Coat: Benjamin Moore Moorcraft Block Filler (145) applied as necessary to produce a smooth, dense surface.
 - c. Finish Coats: Two (2) coats of Benjamin Moore Moorcraft Satin Finish Enamel (250); 1.5 dry mils for each coat (spray, brush or roller applied).
4. System C - Drywall (Low-Sheen Latex)
- a. Surface Preparation: Prepare surfaces in accordance with the specifications for drywall.
 - b. Prime Coat: Benjamin Moore Moorcraft Vinyl Latex Primer (252); 1 dry mil (spray, brush or roller applied).
 - c. Finish Coats: Two (2) coats of Benjamin Moore Moorcraft Vinyl Latex Flat (251); 1.5 dry mils for each coat (spray, brush or roller applied).
5. System D - Drywall (Satin Alkyd)
- a. Surface Preparation: Prepare surfaces in accordance with the specifications for drywall.
 - b. Prime Coat: Benjamin Moore Moorcraft Vinyl Latex Primer (252); 1 dry mil (spray, brush or roller applied).
 - c. Finish Coats: Two (2) coats of Benjamin Moore Moorcraft Satin Finish Enamel (250); 1.5 dry mils for each coat (spray, brush or roller applied).
6. System E – Wood, PVC and Plywood - Painted Finish (Satin Alkyd):
- a. Surface Preparation: Prepare surfaces in accordance with specifications for wood surfaces.

- b. Primer Coat: Benjamin Moore Moorcraft Alkyd Enamel Underbody (247); 1.5 dry mils (spray, brush or roller applied).
 - c. Finish Coats: Two (2) coats of Benjamin Moore Moorcraft Satin Finish Enamel (250); 1.5 dry mils for each coat (spray, brush or roller applied).
7. System F - Wood - Transparent Finish (Stan and Clear Satin Polyurethane Finish):
- a. Surface Preparation: Prepare surfaces in accordance with specification for wood.
 - b. First Coat: Benjamin Moore Penetrating Stain (241).
 - c. Second Coat: Benjamin Moore Benwood Polyurethane Finish (428) Gloss Finish; 1.0 dry mil film thickness (spray, brush or roller applied).
 - d. Third Coat: Benjamin Moore Benwood Polyurethane Finish (435) Semi-Gloss Finish; 1.0 dry mil film thickness (spray, brush or roller applied).
8. System G - Concrete Floors (Epoxy):
- a. Surface Preparation: Brush blast concrete floors to provide a dense 2 mil anchor profile. Acid surface etching will be allowed.
 - b. Prime Coat: Benjamin Moore I.M.C Epoxy-Ester Enamel (M25) applied at a rate of 550 square feet per gallon.
 - c. Finish Coat: Same as prime coat except add and thoroughly mix dry, washed, 50 mesh silica sand to paint as directed by the Engineer to produce a satisfactory slip-resistant surface.

C. Mechanical and Electrical Work:

Except for manufacturer painted items, paint all exposed mechanical and fire protection piping, valves, fittings, traps, conduit, miscellaneous fittings and boxes, pipe and duct insulation, steel hangers and attachments, floor, ceiling and wall plates (except those which are plated), ducts, diffusers, grilles, supports, clamps, straps, etc., in rooms and spaces designated to be finish painted. Painting systems shall be based on the surface and its environment, as approved by the Resident.

D. Equipment:

In general, switchboards, disconnect switches, motors, light and power panels, etc., will be completely shop finished by the manufacturers. All equipment shall be touched-up by the installer where finish is damaged during installation.

3.11 PAINTING SCHEDULE

SURFACE	SYSTEM
A. Interior	
1. Concrete and Concrete Masonry Unit Walls	B
2. Concrete Floors (including equipment pads)	G
3. Metals	
a. Steel Doors and Steel Frames	A(2)
b. Exposed Conduit, Light Fixture Pendants, Pipe, etc.	A(2)
4. Gypsum Wallboard	
a. Walls and exposed ceilings	D
5. Wood and PVC	
a. Standing and Running Trim	E
b. Shelves	E
c. Interior Wood Surfaces of Casework	F
B. Exterior	
1. Metal	
a. Steel Doors and Frames	A(1)
b. Bollards	A(1)
c. Structural Steel for Canopy (Exposed)	A(1)
2. PVC	
a. Trim	E
b. Soffit	E
c. Back-priming (fascia backup-panels, trim, etc.)	E (primer only)

Note: All colors will be custom colors as selected by the Engineer.

- C. In general, miscellaneous brackets, angles, plates, etc., shall receive the same finish coats as the items to which they are associated. Surface preparation and prime coats shall be as specified for similar materials in the same space/environment or as otherwise directed by the Engineer.
- D. In general, ductwork, piping and conduit running exposed on walls and ceilings (including attachment devices, supports, accessories, etc.) shall receive the same type finish coat as adjacent surfaces. Surface preparation and prime coats shall be as specified for similar materials in the same space/environment or as otherwise directed by the Engineer.
- E. Prime galvanized steel and aluminum with Benjamin Moore Galvanized Metal Primer (155), or an approved equal, before applying finish coats.

END OF SECTION

SECTION 10142

ROOM-IDENTIFICATION SIGNAGE

PART 1 - GENERAL

1.1 RELATED DOCUMENTS

- A. Drawings and general provisions of the Contract, including General and Supplementary Conditions and Division 01 Specification Sections, apply to this Section.

1.2 SUMMARY

- A. Section includes room-identification signs that are directly attached to the building.

1.3 DEFINITIONS

- A. Accessible: In accordance with the accessibility standard.

1.4 ACTION SUBMITTALS

- A. Product Data: For each type of product.
- B. Shop Drawings: For room-identification signs.
 - 1. Include fabrication and installation details and attachments to other work.
 - 2. Show sign mounting heights, locations of supplementary supports to be provided by other installers, and accessories.
 - 3. Show message list, tpestyles, graphic elements, including raised characters and Braille, and layout for each sign at least half size.
- C. Samples for Initial Selection: For each type of sign assembly, exposed component, and exposed finish.
 - 1. Include representative Samples of available tpestyles and graphic symbols.
- D. Product Schedule: For room-identification signs. Use same designations indicated on Drawings or specified.

1.5 INFORMATIONAL SUBMITTALS

- A. Qualification Data: For Installer and manufacturer.
- B. Sample Warranty: For special warranty.

1.6 CLOSEOUT SUBMITTALS

- A. Maintenance Data: For signs to include in maintenance manuals.

1.7 QUALITY ASSURANCE

- A. Installer Qualifications: An entity that employs installers and supervisors who are trained and approved by manufacturer.

1.8 WARRANTY

- A. Special Warranty: Manufacturer agrees to repair or replace components of signs that fail in materials or workmanship within specified warranty period.
 - 1. Failures include, but are not limited to, the following:
 - a. Deterioration of finishes beyond normal weathering.
 - b. Deterioration of embedded graphic image.
 - c. Separation or delamination of sheet materials and components.
 - 2. Warranty Period: Five years from date of Substantial Completion.

PART 2 - PRODUCTS

2.1 PERFORMANCE REQUIREMENTS

- A. Accessibility Standard: Comply with applicable provisions in the USDOJ's "2010 ADA Standards for Accessible Design", the ABA standards of the Federal agency having jurisdiction, and ICC A117.1.

2.2 ROOM-IDENTIFICATION SIGNS

- A. Room-Identification Sign: Sign with smooth, uniform surfaces; with message and characters having uniform faces, sharp corners, and precisely formed lines and profiles; and as follows:
 - 1. Manufacturers: Subject to compliance with requirements, available manufacturers offering products that may be incorporated into the Work include, but are not limited to the following:
 - a. Allen Industries Architectural Signage.
 - b. APCO Graphics, Inc.
 - c. ASE, Inc.
 - d. ASI Sign Systems, Inc.
 - e. Best Sign Systems, Inc.
 - f. InPro Corporation (IPC).

- g. Mohawk Sign Systems.
 - h. Signature Signs, Inc.
 - i. Vomar Products, Inc.
2. Laminated-Sheet Sign: Photopolymer face sheet with raised graphics laminated over subsurface graphics to acrylic or phenolic backing sheet to produce composite sheet.
 - a. Composite-Sheet Thickness: Manufacturer's standard for size of sign.
 - b. Surface-Applied Graphics: Applied paint.
 - c. Color(s): As selected by Architect from manufacturer's full range.
 3. Sign-Panel Perimeter: Finish edges smooth.
 - a. Edge Condition: Bullnosed.
 - b. Corner Condition in Elevation: Rounded to radius.
 4. Mounting: Surface mounted to wall with hook-and-loop tape.
 5. Text and Typeface: Accessible raised characters and Braille; typeface as selected by Architect from manufacturer's full range. Finish raised characters to contrast with background color, and finish Braille to match background color.

2.3 SIGN MATERIALS

- A. Acrylic Sheet: ASTM D 4802, category as standard with manufacturer for each sign, Type UVF (UV filtering).
- B. Paints and Coatings for Sheet Materials: Inks, dyes, and paints that are recommended by manufacturer for optimum adherence to surface and are UV and water resistant for colors and exposure indicated.

2.4 ACCESSORIES

- A. Fasteners and Anchors: Manufacturer's standard as required for secure anchorage of signs, noncorrosive and compatible with each material joined, and complying with the following:
- B. Hook-and-Loop Tape: Manufacturer's standard two-part tape consisting of hooked part on sign back and looped side on mounting surface.

2.5 FABRICATION

- A. General: Provide manufacturer's standard sign assemblies according to requirements indicated.
 1. Preassemble signs and assemblies in the shop to greatest extent possible. Disassemble signs and assemblies only as necessary for shipping and handling

limitations. Clearly mark units for reassembly and installation; apply markings in locations concealed from view after final assembly.

2. Mill joints to a tight, hairline fit. Form assemblies and joints exposed to weather to resist water penetration and retention.
3. Conceal connections if possible; otherwise, locate connections where they are inconspicuous.

2.6 GENERAL FINISH REQUIREMENTS

- A. Protect mechanical finishes on exposed surfaces from damage by applying a strippable, temporary protective covering before shipping.
- B. Appearance of Finished Work: Noticeable variations in same piece are not acceptable. Variations in appearance of adjoining components are acceptable if they are within the range of approved Samples and are assembled or installed to minimize contrast.

PART 3 - EXECUTION

3.1 INSTALLATION

- A. General: Install signs using mounting methods indicated and according to manufacturer's written instructions.
 1. Install signs level, plumb, true to line, and at locations and heights indicated, with sign surfaces free of distortion and other defects in appearance.
 2. Install signs so they do not protrude or obstruct according to the accessibility standard.
 3. Before installation, verify that sign surfaces are clean and free of materials or debris that would impair installation.
- B. Accessibility: Install signs in locations on walls according to the accessibility standard.
- C. Mounting Methods:
 1. Hook-and-Loop Tape: Clean bond-breaking materials from substrate surface and remove loose debris. Apply sign component of two-part tape strips symmetrically to back of sign and of suitable quantity to support weight of sign without slippage; push to engage tape adhesive. Keep tape strips 0.250 inch away from edges to prevent visibility at sign edges when sign is initially installed or reinstalled. Apply substrate component of tape to substrate in locations aligning with tape on back of sign; push and rub well to fully engage tape adhesive to substrate.

3.2 ADJUSTING AND CLEANING

- A. Remove and replace damaged or deformed signs and signs that do not comply with specified requirements. Replace signs with damaged or deteriorated finishes or

components that cannot be successfully repaired by finish touchup or similar minor repair procedures.

- B. Remove temporary protective coverings and strippable films as signs are installed.
- C. On completion of installation, clean exposed surfaces of signs according to manufacturer's written instructions, and touch up minor nicks and abrasions in finish. Maintain signs in a clean condition during construction and protect from damage until acceptance by Owner.

END OF SECTION

SECTION 10200MISCELLANEOUS

PART 1 - DESCRIPTION

1.1 RELATED DOCUMENTS

- A. Examine Drawings, Contract Conditions all other Sections of the Specifications for requirements which affect work of this Section whether or not such work is specifically mentioned in this Section.
- B. Coordinate work with that of all other trades affecting, or affected by work of this Section. Cooperate with such trades to assure the steady progress of all Project work.

1.2 DESCRIPTION

The work in this section consists of furnishing all materials, equipment, labor and supervision, and performing all operations required to furnish and install all miscellaneous items as shown on the Drawings, as specified herein, and as is additionally necessary to properly complete the work.

1.3 SHOP DRAWINGS

Submit eight (8) copies of shop drawings for louvers, lockers, flagpole, mop hanger, shelving & supports. Submit eight (8) copies of catalog cuts for all items and materials supplied.

PART 2 - MATERIALS

2.01 MOP HANGER

Mop hanger shall be 24 inches long, 3 inches wide stainless steel with three (3) rubber tool grips equal to Catalog No. 889-CC as manufactured by Crane Plumbing and Fiat Products, or equal by Florestone or E.L. Mustee & Sons, Inc.

2.02 LOUVERS

- A. Where indicated on the Drawings, install Airolite type K6774 Horizontal drainable louvers with 4 inch deep blades. Blades and frame shall be extruded aluminum 12 gauge alloy 6063-T52, with "Kawneer 500" finish, custom color to match the windows and frames. Louvers shall be fitted with 16 gauge aluminum bird screen in extruded aluminum frames. Louvers shall bear AMCA certified ratings seals for air performance and water penetration. Similar louvers by Construction Specialties, Inc. or Rusken Mfg. Div., Phillip Industries Inc. will be considered for use. Where indicated, detail and

fabricate louvers so as to be readily removable from the secure side (interior). Hollow metal frames shall be supplied under Section 08110.

- B. Where indicated on the Drawings, install Airolite type K611 horizontal blade, sightproof louvers (inverted Y) with 4 inch deep blades. Blades and frame shall be extruded aluminum 12 gauge alloy 6063-T52, with "Kawneer 500" finish, custom color to match the windows and frames. Louvers shall be fitted with 16 gauge aluminum bird screen in extruded aluminum frames. The Contractor shall submit the manufacturer's data derived in accordance with AMCA Standard 500 on a 4 foot by 4 foot unit demonstrating that it provided a minimum of 4.11 square feet of free area and shall intake 600 fpm free area at a static pressure drop not exceeding 0.15 inch H₂O. Similar louvers by Construction Specialties, Inc. or Rusken Mfg. Div., Phillip Industries Inc. will be considered for use. Where indicated, detail and fabricate louvers so as to be readily removable from the secure side (interior). Hollow metal frames shall be supplied under Section 08110.
- C. See Mechanical Specifications for automatic dampers.

2.03 CASH DROP UNIT (SAFE)

Cash drop unit (safe) will be supplied by the Authority.

2.04 CURRENCY SCANNER & COIN SORTER UNITS

Currency Scanner and coin sorter units will be supplied by the Authority.

2.05 LOCKERS

- A. Metal Lockers shall be similar to Global Industries "Infinity" Locker. Lockers shall be Double Tier 12" x 18" x 36" in 6-Door assembled profile. Each door shall have a stainless steel recessed door latch suitable for padlock. Each locker shall have 3 clothes hooks (one per side/rear).
- B. Factory applied paint color shall be selected by the Architect.

2.06 SHELVING AND SUPPORTS

- A. Shelving shall be ¾" plywood or particleboard core melamine-clad units in sizes indicated. All faces and edges shall be melamine clad. Color shall be white.
- B. Supports shall be similar to Knappe & Vogt steel heavy-duty #85 Series vertical standards and #185 Series brackets. Bracket shall be full depth of shelf, unless indicated otherwise.

2.07 TRASH RECEPTACLES

- A. Trash Receptacles will be supplied by the Authority.

2.08 FILE CABINETS

- A. File cabinets will be supplied by the Authority.

2.09 FLAGPOLES

Flagpoles shall be seamless cone tapered aluminum 6063-T6 alloy, 30' (exposed) with a mechanical Class I clear anodized finish for two flags as manufactured by American Flagpole. All fittings, such as ball finial, double revolving truck, two halyard and four snaphooks, two cleats, and pole mounting assembly shall be as manufactured by or recommended by the flagpole manufacturer. Similar flagpoles and appurtenances manufactured by Concord Industries Inc., or EMC, a Division of Eder Manufacturing Corp. may also be acceptable.

2.10 ALUMINUM GRATING

Aluminum grating shall be flush top, SGF Series by Ohio Grating Inc., or approved equal. Bearing bars shall be rectangular 1-1/2" X 3/16" thick and spaced 1-3/16 inches on center maximum. Cross bars shall be locked at right angles to, and on the same plane as, the top surface of bearing bars and spaced 2 inches on center maximum. Finish shall be anodized aluminum.

PART 3 - EXECUTION

3.1 MOP HANGER

Install mop hanger in accordance with the manufacturer's instructions.

3.2 LOUVERS

Install louvers as shown on the approved shop drawings and in strict accordance with the manufacturers' instructions.

3.3 CASH DROP UNIT (SAFE), CURRENCY SCANNER AND COIN SORTER

Place cash drop unit, currency scanners and coin sorters in position after all surrounding work has been completed and approved. Safe, currency scanners and coin sorters supplied by the Authority.

3.4 FLAGPOLES

- A. Before installation, when flagpoles are to be stored on site for an extended period, remove all wrapping material and store poles in a dry place, off the ground.
- B. Flagpole shall be installed by a manufacturer trained and approved erection crew experienced in handling, assembling and erecting poles, in strict accordance with the manufacturer's instructions and as shown on the approved Shop Drawings.

3.5 ALUMINUM GRATING

- A. Install aluminum grating at Utility Pit in accordance with the manufacturer's instructions.

3.6 SHELVES AND SUPPORTS

- A. Install shelves and supports in accordance with the manufacturer's written installation instructions and as indicated.

3.7 LOCKERS

- A. Install lockers in location indicated and in accordance with manufacturer's installation instructions. Anchor lockers to wall framing.

END OF SECTION

SECTION 10211

PHENOLIC-CORE TOILET COMPARTMENTS

PART 1 - GENERAL

1.1 RELATED DOCUMENTS

- A. Drawings and general provisions of the Contract, including General and Supplementary Conditions and Division 01 Specification Sections, apply to this Section.

1.2 SUMMARY

A. Section Includes:

- 1. Phenolic-core toilet compartments configured as toilet enclosures and urinal screens.

B. Related Requirements:

- 1. Section 10600 "Toilet Accessories" for toilet tissue dispensers, grab bars, purse shelves, and similar accessories mounted on toilet compartments.

1.3 ACTION SUBMITTALS

A. Product Data: For each type of product.

- 1. Include construction details, material descriptions, dimensions of individual components and profiles, and finishes for toilet compartments.

B. Shop Drawings: For toilet compartments.

- 1. Include plans, elevations, sections, details, and attachment details.
- 2. Show locations of cutouts for compartment-mounted toilet accessories.
- 3. Show locations of centerlines of toilet fixtures.
- 4. Show overhead support or bracing locations.

C. Samples for Initial Selection: For each type of toilet compartment material indicated.

- 1. Include Samples of hardware and accessories involving material and color selection.

D. Product Schedule: For toilet compartments, prepared by or under the supervision of supplier, detailing location and selected colors for toilet compartment material.

1.4 INFORMATIONAL SUBMITTALS

A. Product Certificates: For each type of toilet compartment.

1.5 CLOSEOUT SUBMITTALS

- A. Maintenance Data: For toilet compartments to include in maintenance manuals.

1.6 MAINTENANCE MATERIAL SUBMITTALS

- A. Furnish extra materials that match products installed and that are packaged with protective covering for storage and identified with labels describing contents.
 - 1. Door Hinges: Four hinges with associated fasteners.
 - 2. Latch and Keeper: Two latches and keepers with associated fasteners.
 - 3. Door Bumper: Two door bumpers with associated fasteners.
 - 4. Door Pull: Two door pulls with associated fasteners.
 - 5. Fasteners: Ten fasteners of each size and type.

1.7 PROJECT CONDITIONS

- A. Field Measurements: Verify actual locations of toilet fixtures, walls, columns, ceilings, and other construction contiguous with toilet compartments by field measurements before fabrication.

PART 2 - PRODUCTS

2.1 PERFORMANCE REQUIREMENTS

- A. Surface-Burning Characteristics: Comply with ASTM E 84; testing by a qualified testing agency. Identify products with appropriate markings of applicable testing agency.
 - 1. Flame-Spread Index: 25 or less.
 - 2. Smoke-Developed Index: 450 or less.
- B. Regulatory Requirements: Comply with applicable provisions in [the U.S. Architectural & Transportation Barriers Compliance Board's ADA-ABA Accessibility Guidelines for Buildings and Facilities and ICC A117.1 for toilet compartments designated as accessible.

2.2 PHENOLIC-CORE TOILET COMPARTMENTS

- A. Manufacturers: Subject to compliance with requirements, available manufacturers offering products that may be incorporated into the Work include, but are not limited to the following:
 - 1. Accurate Partitions Corp.; ASI Group.
 - 2. American Sanitary Partition Corporation.
 - 3. Bobrick Washroom Equipment, Inc.
 - 4. Bradley Corporation.

5. General Partitions Mfg. Corp.
6. Global Partitions; ASI Group.
7. Knickerbocker Partition Corporation.
8. Marlite.
9. Metpar Corp.

- B. Toilet-Enclosure Style: Overhead braced.
- C. Urinal-Screen Style: Wall hung.
- D. Door, Panel, Screen, and Pilaster Construction: Solid phenolic-core panel material with melamine facing on both sides fused to substrate during panel manufacture (not separately laminated), and with eased and polished edges and no-sightline system. Provide minimum 3/4-inch- thick doors and pilasters and minimum 1/2-inch- thick panels.
- E. Pilaster Shoes and Sleeves (Caps): Formed from stainless-steel sheet, not less than 0.031-inch nominal thickness and 3 inches high, finished to match hardware.
- F. Brackets (Fittings):
1. Full-Height (Continuous) Type: Manufacturer's standard design; aluminum.
- G. Phenolic-Panel Finish:
1. Facing Sheet Finish: One color and pattern in each room.
 2. Color and Pattern: As selected by Architect from manufacturer's full range, with manufacturer's standard through-color core matching face sheet.
 3. Edge Color: Through-color matching facing sheet color.

2.3 HARDWARE AND ACCESSORIES

- A. Hardware and Accessories: Manufacturer's standard operating hardware and accessories.
1. Material: Clear-anodized aluminum.
 2. Hinges: Manufacturer's standard paired, self-closing type that can be adjusted to hold doors open at any angle up to 90 degrees, allowing emergency access by lifting door.
 3. Latch and Keeper: Manufacturer's standard surface-mounted latch unit designed for emergency access and with combination rubber-faced door strike and keeper. Provide units that comply with regulatory requirements for accessibility at compartments designated as accessible.
 4. Coat Hook: Manufacturer's standard combination hook and rubber-tipped bumper, sized to prevent in-swinging door from hitting compartment-mounted accessories.
 5. Door Bumper: Manufacturer's standard rubber-tipped bumper at out-swinging door.
 6. Door Pull: Manufacturer's standard unit at out-swinging doors that complies with regulatory requirements for accessibility. Provide units on both sides of doors at compartments designated as accessible.

- B. Overhead Bracing: Manufacturer's standard continuous, extruded-aluminum head rail with antigrip profile and in manufacturer's standard finish.
- C. Anchorages and Fasteners: Manufacturer's standard exposed fasteners of stainless steel, finished to match the items they are securing, with theft-resistant-type heads. Provide sex-type bolts for through-bolt applications. For concealed anchors, use stainless-steel, hot-dip galvanized-steel, or other rust-resistant, protective-coated steel compatible with related materials.

2.4 MATERIALS

- A. Aluminum Castings: ASTM B 26/B 26M.
- B. Aluminum Extrusions: ASTM B 221.
- C. Stainless-Steel Sheet: ASTM A 666, Type 304, stretcher-leveled standard of flatness.
- D. Stainless-Steel Castings: ASTM A 743/A 743M.

2.5 FABRICATION

- A. Fabrication, General: Fabricate toilet compartment components to sizes indicated. Coordinate requirements and provide cutouts for through-partition toilet accessories where required for attachment of toilet accessories.
- B. Overhead-Braced Units: Provide manufacturer's standard corrosion-resistant supports, leveling mechanism, and anchors at pilasters to suit floor conditions. Provide shoes at pilasters to conceal supports and leveling mechanism.
- C. Door Size and Swings: Unless otherwise indicated, provide 24-inch- wide in-swinging doors for standard toilet compartments and 36-inch- wide out-swinging doors with a minimum 32-inch- wide clear opening for compartments designated as accessible.

PART 3 - EXECUTION

3.1 EXAMINATION

- A. Examine areas and conditions, with Installer present, for compliance with requirements for fastening, support, alignment, operating clearances, and other conditions affecting performance of the Work.
 - 1. Confirm location and adequacy of blocking and supports required for installation.
- B. Proceed with installation only after unsatisfactory conditions have been corrected.

3.2 INSTALLATION

- A. General: Comply with manufacturer's written installation instructions. Install units rigid, straight, level, and plumb. Secure units in position with manufacturer's recommended anchoring devices.
 - 1. Full-Height (Continuous) Brackets: Secure panels to walls and to pilasters with full-height brackets.
 - a. Locate bracket fasteners so holes for wall anchors occur in masonry or tile joints.
 - b. Align brackets at pilasters with brackets at walls.
- B. Overhead-Braced Units: Secure pilasters to floor and level, plumb, and tighten. Set pilasters with anchors penetrating not less than 1-3/4 inches into structural floor unless otherwise indicated in manufacturer's written instructions. Secure continuous head rail to each pilaster with no fewer than two fasteners. Hang doors to align tops of doors with tops of panels, and adjust so tops of doors are parallel with overhead brace when doors are in closed position.
- C. Urinal Screens: Attach with anchoring devices to suit supporting structure. Set units level and plumb, rigid, and secured to resist lateral impact.

3.3 ADJUSTING

- A. Hardware Adjustment: Adjust and lubricate hardware according to hardware manufacturer's written instructions for proper operation. Set hinges on in-swinging doors to hold doors open approximately 30 degrees from closed position when unlatched. Set hinges on out-swinging doors to return doors to fully closed position.

END OF SECTION

SECTION 10520

FIRE EXTINGUISHER

PART 1 - GENERAL

1.1 RELATED DOCUMENTS

- A. Examine Drawings, Contract Conditions all other Sections of the Specifications for requirements which affect work of this Section whether or not such work is specifically mentioned in this Section.
- B. Coordinate work with that of all other trades affecting, or affected by work of this Section. Cooperate with such trades to assure the steady progress of all Project work.

1.2 DESCRIPTION

The work in this section consists of furnishing all materials, equipment, transportation, labor and supervision, and performing all operations required to install all fire extinguishers and mounting brackets as shown on the Drawings, as specified herein, and as is additionally required to properly complete the work.

1.3 SUBMITTALS

Submit eight (8) copies of material brochures and installation instructions and details for approval.

1.4 GENERAL

- A. Provide fire extinguishers, mounting brackets, and accessories manufactured by the same company.
- B. Provide fire extinguishers which are U.L. listed and bear U.L. "Listing Mark" for type, rating and classification of extinguisher indicated. All fire extinguishers shall be rechargeable.

PART 2 - MATERIALS

2.1 PRODUCTS

- A. Unless otherwise indicated, the fire extinguishers, brackets and accessories are as manufactured by J. L. Industries. Equivalent models manufactured by Ansul Co. or Walter Kidde and Co. are also acceptable.

- B. Fire extinguishers shall be multi-purpose 10 lb. dry chemical for A, B & C fires, complete with an accurate pressure safety gauge, Model Cosmic 10E with Bracket No. MB 846. Refer to the Drawings for locations.

PART 3 - EXECUTION

3.1 INSTALLATION

- A. Install brackets and extinguishers in the locations indicated on the Drawings at mounting heights to comply with applicable regulations of governing authorities.
- B. Securely fasten mounting brackets to structure, with proper reinforcement, square and plumb, to comply with manufacturer's approved installation instructions.
- C. Check extinguishers for proper charge operations. Remove and replace damaged, defective and undercharged units.

END OF SECTION

SECTION 10600

TOILET ACCESSORIES

PART 1 - GENERAL

1.01 RELATED DOCUMENTS

- A. Examine Drawings, Contract Conditions all other Sections of the Specifications for requirements which affect work of this Section whether or not such work is specifically mentioned in this Section.
- B. Coordinate work with that of all other trades affecting, or affected by work of this Section. Cooperate with such trades to assure the steady progress of all Project work.

1.02 DESCRIPTION

The work in this section consists of furnishing all materials, equipment, supplies, labor and supervision, and performing all operations required to install all toilet accessories as shown on the Drawings, as specified herein, and as is additionally required to properly complete the work.

1.03 SUBMITTALS

Submit eight (8) copies of manufacturers' product data for approval. Product data shall indicate all materials, dimensions, gauges of steel, assembly, hardware and finishes.

PART 2 - MATERIALS

2.01 TOILET ACCESSORIES

- A. All toilet accessories shall be as manufactured by Bobrick Washroom Equipment Inc., Bradley Corp., or ASI.

Catalog numbers listed below are for Bobrick Products.

Mirror	B-290-2436
Sanitary Disposal Unit	B-270
Soap Dispenser with Shelf	Furnished by MTA, Install by GC
Paper Towel Dispenser	Furnished by MTA, Install by GC
Waste Receptacle	Furnished by MTA, Install by GC
Toilet Roll Holders	Furnished by MTA, Install by GC

- B. Grab Bars: Grab bars shall be satin finish stainless steel, 1 1/2 inch diameter, of the lengths shown, with concealed mounting flanges, and mounting flange cover plate with

four set screws for securing. Bars shall be equal to Bobrick Products B 5806x36 & B 5806x42.

- C. Obtain all toilet accessories from a single manufacturer.

PART 3 - EXECUTION

3.01 INSTALLATION

Install accessories where shown on the Drawings, in accordance with the manufacturer's approved instructions.

END OF SECTION

SECTION 11460

KITCHEN EQUIPMENT

PART 1 - DESCRIPTION

1.1 RELATED DOCUMENTS

- A. Examine Drawings, Contract Conditions all other Sections of the Specifications for requirements which affect work of this Section whether or not such work is specifically mentioned in this Section.
- B. Coordinate work with that of all other trades affecting, or affected by work of this Section. Cooperate with such trades to assure the steady progress of all Project work.

1.2 DESCRIPTION

The work in this section consists of furnishing all materials, equipment, supplies, transportation, and performing all operations required to install complete, in-place, kitchen equipment as shown on the drawings, as specified herein and as is additionally required to properly complete the work.

1.3 SHOP DRAWINGS

Submit eight (8) copies of shop drawings showing all details of equipment specified along with installation instructions and operations manuals.

PART 2 - MATERIALS

2.1 KITCHEN EQUIPMENT

- A. Provide the following appliances:
 - 1. Refrigerator: General Electric Model no. GTS18DCP
 - a. Size: 17.9 cu. ft.
 - 2. Microwave Oven: General Electric Model no. JEM31
 - a. Size: 1.0 cu. ft.
- B. The Contractor shall provide the Authority with a full one year warranty on the kitchen equipment.

PART 3 – INSTALLATION

3.1 INSTALLATION

- A. General: Comply with manufacturer's instructions and recommendations.
- B. Built-In Equipment: Securely anchor units to supporting cabinetry or countertops with concealed fasteners. Verify that clearances area adequate for proper functioning and rough openings are completely concealed.
- C. Freestanding Equipment: Place units in final locations after finishes have been completed in each area. Verify that clearances are adequate for proper appliance operation.
- D. Utilities: Refer to Divisions 15 and 16 for plumbing and electrical requirements.

3.2 ADJUST AND CLEAN

- A. Testing: Test each item of equipment to verify proper operation. Make any necessary adjustments to ensure proper operations.

END OF SECTION

SECTION 12356

KITCHEN CASEWORK

PART 1 – GENERAL

1.1 RELATED DOCUMENTS

- A. Examine Drawings, Contract Conditions all other Sections of the Specifications for requirements which affect work of this Section whether or not such work is specifically mentioned in this Section.
- B. Coordinate work with that of all other trades affecting, or affected by work of this Section. Cooperate with such trades to assure the steady progress of all Project work.

1.2 SUMMARY

- A. This Section includes the following:
 - 1. Plastic-laminate-faced kitchen cabinets.
 - 2. Plastic-laminate countertops.

1.3 DEFINITIONS

- A. Exposed Surfaces of Casework: Surfaces visible when doors and drawers are closed, including visible surfaces in open cabinets or behind glass doors.
- B. Semiexposed Surfaces of Casework: Surfaces behind opaque doors or drawer fronts, including interior faces of doors and interiors and sides of drawers. Bottoms of wall cabinets are defined as "semiexposed."
- C. Concealed Surfaces of Casework: Surfaces not usually visible after installation, including sleepers, web frames, dust panels, bottoms of drawers, and ends of cabinets installed directly against and completely concealed by walls or other cabinets. Tops of wall cabinets and utility cabinets are defined as "concealed."

1.4 SUBMITTALS

- A. Product Data: For the following:
 - 1. Cabinets.
 - 2. Plastic-laminate countertops.
 - 3. Cabinet hardware.

- B. Shop Drawings: For cabinets and countertops. Include plans, elevations, details, and attachments to other work. Show materials, finishes, filler panels, hardware, edge and backsplash profiles, cutouts for plumbing fixtures, and methods of joining countertops.
- C. Samples for Initial Selection: Manufacturer's color charts consisting of units or sections of units showing the full range of colors, textures, and patterns available for each type of material exposed to view.
- D. Product Certificates: Signed by manufacturers of casework certifying that products furnished comply with requirements.

1.5 QUALITY ASSURANCE

- A. Source Limitations for Cabinets: Obtain cabinets through one source from a single manufacturer.
- B. Quality Standards: Unless otherwise indicated, comply with the following standards:
 - 1. Cabinets: KCMA A161.1.
 - a. KCMA Certification: Provide cabinets with KCMA's "Certified Cabinet" seal affixed in a semiexposed location of each unit and showing compliance with the above standard.

1.6 PROJECT CONDITIONS

- A. Environmental Limitations: Do not deliver or install kitchen casework until building is enclosed, wet-work is complete, and HVAC system is operating and will maintain temperature and relative humidity at occupancy levels during the remainder of the construction period.
- B. Established Dimensions: Where kitchen casework is indicated to fit to other construction, establish dimensions for areas where casework is to fit. Coordinate construction to ensure that actual dimensions correspond to established dimensions. Provide fillers and scribes to allow for trimming and fitting.
- C. Field Measurements: Where kitchen casework is indicated to fit to existing construction, verify dimensions of existing construction by field measurements before fabrication and indicate measurements on Shop Drawings. Provide fillers and scribes if necessary.
- D. Field Measurements for Countertops: Verify dimensions of countertops by field measurements after base cabinets are installed but before countertop fabrication is complete. Coordinate fabrication schedule with construction progress to avoid delaying the Work.

1.7 COORDINATION

- A. Coordinate layout and installation of blocking and reinforcement in partitions for support of kitchen casework.

PART 2 – PRODUCTS

2.1 MANUFACTURERS

- A. Manufacturers: Subject to compliance with requirements, manufacturers offering products that may be incorporated into the Work include, but are not limited to, the following:

- 1. Cabinets: Similar to “Rutland II” by Merillat Industries LLC.
- 2. Plastic Laminate for Countertops:
 - a. Formica Corp.
 - b. Laminart.
 - c. Nevamar Corp.
 - d. Westinghouse Electric Corp.; Specialty Products Div.
 - f. Wilson: Ralph Wilson Plastics Co.

2.2 COLORS, TEXTURES, AND PATTERNS

- A. Colors, Textures, and Patterns: As selected by Architect from manufacturer's full range for these characteristics.

2.3 CABINET MATERIALS

- A. Exposed Materials: Comply with the following:

- 1. Plastic Laminate: High-pressure decorative laminate complying with NEMA LD 3, Grade VGS.
 - a. Where edges of solid-color plastic-laminate sheets will be visible after fabrication, provide through-color plastic laminate.

- B. Semiexposed Materials: Unless otherwise indicated, provide the following:

- 1. Plastic Laminate: High-pressure decorative laminate complying with NEMA LD 3, Grade VGS.

2.4 COUNTERTOP MATERIALS

- A. Plastic Laminate: High-pressure decorative laminate complying with NEMA LD 3.
 - 1. Grade: HGS.
 - 2. Grade: HGP.
 - 3. Provide through-color plastic laminate.
 - 4. Grade for Backer Sheet: BKL.

2.5 CASEWORK HARDWARE

- A. General: Manufacturer's standard units complying with BHMA A156.9, of type, material, size, and finish as selected from manufacturer's standard choices.
- B. Hinges: Concealed European-style hinges.
- C. Drawer Guides: Epoxy-coated-metal, self-closing drawer guides; designed to prevent rebound when drawers are closed; with nylon-tired, ball-bearing rollers; and complying with BHMA A156.9, Type B05091.

2.6 CABINET CONSTRUCTION

- A. Face Style: Flush overlay; door and drawer faces cover cabinet body members or face frames with only enough space between faces for operating clearance.
- B. Face Frames: Frameless.
- C. Door and Drawer Fronts: 1/2-inch-thick particleboard with plastic-laminate faces, backs, and edges. Provide same grade, pattern, color, and texture of plastic laminate for backs and edges as for faces.
- D. Exposed Cabinet Ends: Plastic-laminate-faced particleboard.
- E. Cabinet Tops and Bottoms: 5/8-inch-thick particleboard or 1/2-inch-thick plywood, fully supported by and secured in rabbets in end panels, front frame, and back rail.
- F. Back, Top, and Bottom Rails: 3/4-by-2-1/2-inch solid wood, interlocking with end panels and rabbeted to receive top and bottom panels. Back rails secured under pressure with glue and with mechanical fasteners.
- G. Wall-Hung Unit Back Panels: 3/16-inch-thick plywood fastened to rear edge of end panels and to top and bottom rails.
- H. Base Unit Back Panels: 3/16-inch-thick plywood fastened to rear edge of end panels and to top and bottom rails.

- I. Front Frame Drawer Rails: 3/4-by-1-1/4-inch solid wood mortised and fastened into face frame.
- J. Drawers: Fabricate with exposed fronts fastened to subfront with mounting screws from interior of body.
- K. Shelves: 3/4-inch-thick laminate clad particleboard or 5/8-inch-thick laminate clad plywood.
- L. Joinery: Rabbet backs flush into end panels and secure with concealed mechanical fasteners. Connect tops and bottoms of wall cabinets and bottoms and stretchers of base cabinets to ends and dividers with mechanical fasteners. Rabbet tops, bottoms, and backs into end panels.
- M. Factory Finishing: To greatest extent possible, finish casework at factory. Defer only final touchup until after installation.

2.7 PLASTIC-LAMINATE COUNTERTOPS

- A. Configuration: Provide post-formed countertops at kitchen casework locations. Provide square edge countertops at work surface locations.
- B. Plastic-Laminate Substrate: Particleboard not less than 3/4 inch thick.
 - 1. For countertops at sinks and lavatories, use phenolic-resin particleboard or exterior-grade plywood.
 - 2. Build up countertop thickness to 1-1/2 inches at front, back, and ends with additional layers of particleboard laminated to top.
- C. Backer Sheet: Provide plastic-laminate backer sheet on underside of countertop substrate.

PART 3 – EXECUTION

3.1 INSTALLATION

- A. Install casework with no variations in flushness of adjoining surfaces; use concealed shims. Where casework abuts other finished work, scribe and cut for accurate fit. Provide filler strips, scribe strips, and moldings in finish to match casework face.
- B. Install casework without distortion so doors and drawers fit openings and are aligned. Complete installation of hardware and accessories as indicated.
- C. Install casework and countertop level and plumb to a tolerance of 1/8 inch in 8 feet.
- D. Fasten cabinets to adjacent units and to backing.

- E. Fasten plastic-laminate countertops by screwing through corner blocks of base units into underside of countertop. Form seams using splines to align adjacent surfaces, and secure with glue and concealed clamping devices designed for this purpose.

3.2 ADJUSTING AND CLEANING

- A. Adjust casework and hardware so doors and drawers are centered in openings and operate smoothly without warp or bind. Lubricate operating hardware as recommended by manufacturer.
- B. Clean casework on exposed and semi-exposed surfaces. Touch up factory-applied finishes to restore damaged or soiled areas.

END OF SECTION

SECTION 15000SUPPLEMENTAL MECHANICAL GENERAL REQUIREMENTS

PART 1 - GENERAL

1.1 RELATED DOCUMENTS

- A. The General Provisions, Special Provisions and Notice to Contractors shall apply to this work. Read these to be familiar with conditions related to the installation of the work.

1.2 WORK SHOWN ON DRAWINGS

- A. The drawings accompanying this specification, as a part thereof, are working drawings indicating the location and arrangement of the increments of the systems of this section of work. Material deviation from this arrangement, process or means of application, shall bear the Engineer's review stamp before the change is made on the job or materials are ordered. Changes made without such review shall be ordered removed and items installed as specified shall be provided at no additional expense to the Owner.
- B. The drawings are diagrammatic and are not intended to show in minute detail minor items of installation or materials such as specific fittings or findings.

1.3 MATERIALS AND LABOR

- A. Furnish materials and labor necessary to deliver to the Owner a complete and operable system installed in accordance with the contract documents.
- B. Materials shall be of the best quality. Workmanship shall be of highest grade and construction shall be done according to best practices of the trade.
- C. Provide, when required, labeled samples of material or equipment specified herein or proposed to be used in this work.
- D. Where words "furnish", "provide", or "install" are mentioned, either singly or in combination, these words are hereby interpreted to mean "furnish and install" or "provide and install", including materials complete with connections, supplemental devices, accessories and appurtenances, unless specifically otherwise noted. These words are likewise hereby interpreted as being prefixed to materials, equipment, and apparatus hereinafter mentioned, either in abbreviated or scheduled information or in the technical sections of the specifications.

1.4 EQUIPMENT INSTALLATION IN HEATING SEASON

- A. The system shall be installed provided that the construction area will have sufficient heat to maintain temperature above 40°F throughout the construction period.

- B. Provide temporary heating during the heating in the Administration Building, Toll Booths, and the tunnel during construction, while the new heating equipment is not functional.

1.5 COOPERATION BETWEEN TRADES

- A. Provide information sufficiently in advance of this work, so that work by the other trades may be coordinated and installed without delays. Furnish and locate sleeves, supports, anchors and necessary access panels.
- B. Where work is concealed, assure it does not project beyond finished lines of floors, ceilings, or walls.
- C. Equipment or piping requiring access found to be located above sheetrock ceilings shall be brought immediately to the attention of the Architect for resolution.

1.6 VISITING THE PREMISES

- A. Not applicable.

1.7 ORDINANCES, AUTHORITIES, PERMITS, AND FEES

- A. Obtain necessary permits and licenses, give notices and comply with laws, ordinances, rules, regulations or orders affecting the work, and pay fees and charges in connection therewith.
- B. The "authority having jurisdiction" is the organization, office, or individual responsible for "approving" equipment, an installation, or a procedure.

1.8 PROTECTION OF WORK AND MATERIALS

- A. Protect and care for materials delivered and work performed until the completion of the work. Defective equipment or equipment damaged in the course of storage, installation or test shall be replaced or repaired to the satisfaction of the Engineer at no additional cost to the Owner.

1.9 INSURANCE

- A. Purchase and maintain Public Liability and Property Insurance during the progress of the work and until completion and acceptance of the entire project by the Owner in the amounts as specified in the General Conditions.

1.10 APPLICABLE CODES

- A. Work and materials shall conform to the latest rules and regulations listed below and these rules and regulations hereby are made part of this specification. They include, but are not necessarily limited to the following:
American Society for Testing and Materials (ASTM)

Underwriters' Laboratories, Inc. (UL)
 Air Moving and Conditioning Assoc. (AMCA)
 American Society of Heating, Refrigerating, and Air
 Conditioning Engineers (ASHRAE)
 American Society of Mechanical Engineers (ASME)
 National Electrical Manufacturers Association (NEMA)
 Institute of Electrical and Electronics Engineers (IEEE)
 American National Standards Institute (ANSI)
 National Fire Protection Association (NFPA)
 American Water Works Association (AWWA)
 International Mechanical Codes (IMC)
 International Energy Conservation Code (IECC)
 State Fire Code
 State Plumbing Codes
 American Welding Society

1.11 SHOP DRAWINGS

- A. Submit shop drawings, manufacturers' data and certificates for equipment, system layouts for ductwork, piping, materials and finish, and pertinent details for each system where specified in each individual section, eight (8) copies, to be submitted to the Resident. Shop drawings will be returned "No Exceptions Taken", "Make Corrections Noted", "Amend and Resubmit", "Submit Specified Item", or "Rejected" less two (2) copies. Work shall progress in accordance with "Reviewed" shop drawings (ONLY).
- B. Groups of similar shop drawings shall be submitted as individual bound documents with covers and indexes. Typical similar items would be "Diffusers and Registers", "Valves and Controls". Rejection of individual items shall not be cause for rejection of the entire document.
- C. Clearly indicate item(s) to be reviewed on each submission by highlighting or underlining intended item(s). Submissions not clearly marked shall be returned "Amend and Resubmit".
- D. Shop drawings must bear the Engineer's review stamp. In the event that the Engineer returns shop drawings "Amend and Resubmit" or "Rejected", the shop drawing must be revised and resubmitted for review.
- E. Furnishing of the specified item must still produce the results and performance, dependability and quality reasonably to be expected within the spirit of the specifications, drawings, and the standard of good mechanical performance normal to the trade.

1.12 SUBSTITUTIONS

- A. Where the specifications allow the substitution of a product, still this product is subject to review by the Engineer for approval in accordance with the paragraph entitled "Shop Drawings". Review of a substitute item is an indication only that the

substitute item is compatible with the specified item as a claim of the manufacturer. Insure dimensional propriety, performance, and quality of the substitute item.

- B. Reference in the specifications or on the drawings to any product, material, fixture, form or type of construction, by proprietary name, manufacturer, make or catalog number, establishes a standard of quality or design and is not meant to limit competition. Use any equivalent substitute provided favorable written review by the Engineer is first obtained. The (ONLY) notation in the specification is an exception to this and leaves no option.
- C. For materials or equipment which are supplied with integral or factory applied finish, the colors will be considered in evaluating substitutions.
- D. For the purpose of avoiding conflicts with other trades, contracts, and adjoining work where more than one (1) article, device, material, fixture, form or proprietary name, manufacturer, make or catalog number, the first named shall be used as the basis of design and details. The cost of any changes because of substituted item shall be borne by the Contractor requesting such change.

PART 2 - PRODUCTS

NOT USED

PART 3 - EXECUTION

3.1 GRADES AND ELEVATIONS

- A. Establish and maintain grades and elevations in connection with this work.

3.2 EQUIPMENT SUPPORTS

- A. Furnish and install equipment supports for mechanical equipment as required. Supports shall be subject to review by the Engineer.

3.3 SLEEVES AND PREPARED OPENINGS

- A. Coordinate core-drilling, cutting, patching and setting of sleeves, frames, framing and lintels for openings with other trades. Sleeves shall be furnished by the Contractor. Pipe sleeves shall be provided at all floor and wall penetrations. Sleeves shall be Schedule 40 steel pipe for iron pipe, Type "L" copper for copper pipe and Schedule 40 PVC for plastic pipe. Sleeves shall be firestopped, as specified. Refer to Spec section 15000 for Sleeves, and 15400 Plumbing systems, and Section 15071 for hangers and Supports.
- B. Failure to give timely notice of and to locate openings and furnish sleeves shall cause no additional expense to the Owner.

3.4 CONNECTION TO EQUIPMENT

- A. Provide piping connections, supports, brackets, compensators or flexible connections to prevent application of excessive stresses to equipment.
- B. Equipment shall be installed with flanges or unions in such a manner as to permit disconnecting for removal of tubes, coils, elements and other equipment for inspection, service and repairs.

3.5 ACCESS TO EQUIPMENT

- A. The installation of work performed shall provide reasonable accessibility for operation, inspection, and maintenance of equipment and accessories. The Engineer shall determine the adequacy of such accessibility.

3.6 ACCESS PANELS

- A. Access panels shall be provided where indicated on the drawings and as required for access to valves and other serviceable components. Access doors shall be Milcor, Zurn or approved equal hinged with primed finish and with allen wrench operated latch.
- B. Access panels installed in fire-rated assemblies shall have the same fire rating as the assembly.

3.7 PAINTING OF EQUIPMENT

- A. Exposed ironwork, including steel supports and hangers in unfinished spaces, mechanical rooms, pits, and trenches shall be properly cleaned, prepared and painted with two (2) coats of black asphaltum varnish.

3.8 GUARDS

- A. Exposed moving and rotating elements of mechanical equipment items shall be protected with suitable guards for personnel protection. Guards shall be of rigid construction, firmly positioned. Holes shall be provided in guards at shaft centers to facilitate tachometer readings.

3.9 LUBRICATION

- A. Furnish and install grease fittings for points requiring lubrication. Furnish extension type fittings as required to provide easy access for maintenance lubrication.
- B. Furnish initial charges of lubricants for equipment. Lubricants shall be in conformance with the manufacturer's requirements and recommendations.

3.10 ELECTRIC MOTORS AND MOTOR CONTROLS

- A. Unless otherwise noted, motors, motor starters and other electrical accessories, which are specified under Mechanical specifications shall be selected as noted in spec Section 15700, Common Motor requirements for HVAC Equipment.
- B. Motors shall be built in accordance with the latest applicable NEMA, IEEE and ANSI Standards. Motors shall be manufactured by Baldor, Magnetek or Toshiba, of the latest type and quality specified under individual items of equipment. Motor efficiencies shall be premium high efficiency type per the Consortium for Energy Efficiency Standard and/or be “Energy Star” compliant.
- C. Magnetic motor starters for mechanical items of equipment shall be furnished under Division 16 unless the starter is an integral part of a factory packaged item of equipment. Each starter furnished as an integral item of equipment shall be provided with overload heater elements. Starters shall have single phase protection or shall have relays installed to provide this feature. Starters shall be equipped with suitable step-down transformers to provide required control voltage.
- D. Motors shall have a minimum continuous duty service factor of 1.15. Minimum motor efficiency shall be:

<u>MOTOR HORSEPOWER</u>	<u>PERCENTAGE EFFICIENCY</u>		
	<u>(1200RPM)</u>	<u>(1800 RPM)</u>	<u>(3600 RPM)</u>
1,1-1/2,2,3	----	86.5	85.5
5	89.5	89.5	86.5
7.5	90.2	91.0	88.5
10	91.7	91.7	89.5
15	91.7	93.0	90.2
20	92.4	93.0	91.0
25	93.0	93.6	91.7
30	93.6	94.1	91.7
40	94.1	94.1	92.4
50	94.1	94.5	93.0
60	94.5	95.0	93.6
75 & UP	94.5	95.0	93.6

3.11 CLEANING OF SYSTEMS

- A. Piping and duct systems shall be thoroughly cleaned and flushed prior to initial operation.
- B. Thoroughly clean exposed portions of the mechanical installation, removing labels and foreign substance.
- C. Furnish detergents, solvents, cleaning compounds, and tools required for cleaning operations.

- D. Keep the premises free from accumulation of waste material or rubbish and at the completion of the work, remove from the job site tools, scaffolding, surplus materials, and rubbish, leaving the work areas "broom" clean.

3.12 STARTING OF EQUIPMENT

- A. Testing or starting of equipment shall be done in collaboration with trades concerned to insure safe and proper operation of the equipment.
- B. Prior to starting equipment, provide lubrication at required points. Before starting any electrical or electric motor driven equipment, a check must be made to insure that proper heater coils are installed in the starters and that the equipment is rotating in the proper direction.

3.13 OPERATIONAL TESTING

- A. Operate systems until successful operation is demonstrated to the Engineer. This initial operation shall be in addition to the testing of the system and shall be done after the system is cleaned and finished. Refer to section 15950 for Testing, Adjusting and Balancing (TAB) HVAC Systems

3.14 RECORD DRAWINGS

- A. During construction, keep an accurate record of deviations to the installation of the work as indicated on the drawings. Upon completion of the work, furnish a copy of this record to the Engineer. Submit record drawings for As-Built before requesting final payment.

3.15 MANUFACTURER'S REPRESENTATIVE

- A. As indicated in the Technical Sections of this specification or as directed by the Engineer, provide the services of a factory trained Engineer or Technician to inspect, adjust, and place in proper operating condition the equipment or item involved. No additional compensation will be allowed for such service.

3.16 MANUFACTURER'S INSTRUCTIONS, OPERATION AND MAINTENANCE DATA

- A. Provide for each item of equipment or apparatus furnished, a complete set of printed instructions obtained from the manufacturer covering proper operation, maintenance, lubrication, cleaning, servicing, adjustment, and safety instructions.
- B. Manufacturer's data shall include performance data (curves are preferred where applicable) complete parts lists, recommended spare parts lists, piping, and wiring diagrams.
- C. Arrange data in complete sets, properly indexed and marked.
- D. Data shall include a complete set of shop drawings.

- E. Material shall first be submitted in preliminary form for review by the Engineer. After review, submit three (3) copies in bound volumes to the Engineer for distribution.

3.17 GUARANTEES

- A. An item becomes "defective" when it ceases to conform to the Contract Documents. Guarantees begin on the date of issuance of a certificate authorizing final payment or certificate of substantial completion with the Owner taking occupancy or beneficial use thereafter.
- B. Upon completion of the work and before applying for final payment, furnish a written guarantee, stating that the work complies with the provisions of codes listed herein, and that it will be free from defects of material and workmanship for not less than one (1) year. Guarantee shall further state that the Contractor will, at his own expense, repair or replace any of his material and work which may become defective during the time of guarantee, together with other work damaged as a consequence of such defects.
- C. Where special guarantees, covering installation, operation or performance of any systems, or equipment furnished under are indicated, the full responsibility for the fulfillment of such guarantees must be assumed by the Contractor who shall obtain written guarantees in triplicate, two (2) copies of which shall be filed with the Engineer before final acceptance.
- D. Repeated malfunctioning or failure in service of any item or work of the system is sufficient cause for the Engineer to order the removal of the item, and its replacement with new item at the expense of the Contractor.

3.18 EXISTING UTILITIES AND EQUIPMENT - NONE

3.19 FIRESTOPPING

- A. Firestopping shall be performed in accordance with Specification Section 07841 "Penetration Firestopping". All penetrations of fire-rated assemblies including walls and floors by mechanical system components (piping, ductwork, conduits, etc.) shall be firestopped as specified. Coordinate size, location and type of pipe and duct sleeves as required by firestopping systems.

END OF SECTION

SECTION 15070

VIBRATION AND SEISMIC CONTROLS FOR HVAC

PART 1 - GENERAL

1.1 SUMMARY

A. Section Includes:

1. Elastomeric isolation mounts.
2. Restrained elastomeric isolation mounts.
3. Restrained-spring isolators.
4. Housed restrained spring isolators.
5. Pipe-riser resilient supports.
6. Resilient pipe guides.
7. Elastomeric hangers.
8. Spring hangers.
9. Restraint channel bracings.
10. Restraint cables.
11. Seismic-restraint accessories.
12. Mechanical anchor bolts.

1.2 ACTION SUBMITTALS

A. Product Data: For each type of product.

B. Delegated-Design Submittal: For each vibration isolation and seismic-restraint device.

1. Include design calculations and details for selecting vibration isolators and seismic restraints complying with performance requirements, design criteria, and analysis data signed and sealed by the qualified professional engineer responsible for their preparation.

1.3 INFORMATIONAL SUBMITTALS

A. Welding certificates.

B. Field quality-control reports.

1.4 QUALITY ASSURANCE

A. Comply with seismic-restraint requirements in the IBC unless requirements in this Section are more stringent.

- B. Welding Qualifications: Qualify procedures and personnel according to AWS D1.1/D1.1M, "Structural Welding Code - Steel."
- C. Seismic-restraint devices shall have horizontal and vertical load testing and analysis and shall bear anchorage preapproval OPA number from OSHPD, preapproval by ICC-ES, or preapproval by another agency acceptable to authorities having jurisdiction, showing maximum seismic-restraint ratings. Ratings based on independent testing are preferred to ratings based on calculations. If preapproved ratings are unavailable, submittals based on independent testing are preferred. Calculations (including combining shear and tensile loads) to support seismic-restraint designs must be signed and sealed by a qualified professional engineer.

PART 2 - PRODUCTS

2.1 PERFORMANCE REQUIREMENTS

A. Wind-Restraint Loading:

1. Basic Wind Speed: 150.
2. Building Classification Category: Refer to Architectural drawings.
3. Minimum 30 lb/sq. ft. multiplied by maximum area of HVAC component projected on vertical plane normal to wind direction, and 45 degrees either side of normal.

B. Seismic-Restraint Loading:

1. Site Class as Defined in the IBC: C.
2. Assigned Seismic Use Group or Building Category as Defined in the IBC: II.
 - a. Component Importance Factor: 1.5.
 - b. Component Response Modification Factor: 3.0.
 - c. Component Amplification Factor: 2.5.
3. Design Spectral Response Acceleration at Short Periods (0.2 Second):
4. Design Spectral Response Acceleration at 1.0-Second Period:

2.2 ELASTOMERIC ISOLATION MOUNTS

A. Double-Deflection, Elastomeric Isolation Mounts:

1. Mounting Plates:
 - a. Top Plate: Encapsulated steel load transfer top plates, factory drilled and threaded with threaded studs or bolts.
 - b. Baseplate: Encapsulated steel bottom plates with holes provided for anchoring to support structure.

2. Elastomeric Material: Molded, oil-resistant rubber, neoprene, or other elastomeric material.

2.3 RESTRAINED ELASTOMERIC ISOLATION MOUNTS

A. Restrained Elastomeric Isolation Mounts:

1. Description: All-directional isolator with seismic restraints containing two separate and opposing elastomeric elements that prevent central threaded element and attachment hardware from contacting the housing during normal operation.
 - a. Housing: Cast-ductile iron or welded steel.
 - b. Elastomeric Material: Molded, oil-resistant rubber, neoprene, or other elastomeric material.

2.4 RESTRAINED-SPRING ISOLATORS

A. Freestanding, Laterally Stable, Open-Spring Isolators with Vertical-Limit Stop Restraint:

1. Housing: Steel housing with vertical-limit stops to prevent spring extension due to weight being removed.
 - a. Base with holes for bolting to structure with an elastomeric isolator pad attached to the underside. Bases shall limit floor load to 500 psig.
 - b. Top plate with threaded mounting holes or elastomeric pad.
 - c. Internal leveling bolt that acts as blocking during installation.
2. Restraint: Limit stop as required for equipment and authorities having jurisdiction.
3. Outside Spring Diameter: Not less than 80 percent of the compressed height of the spring at rated load.
4. Minimum Additional Travel: 50 percent of the required deflection at rated load.
5. Lateral Stiffness: More than 80 percent of rated vertical stiffness.
6. Overload Capacity: Support 200 percent of rated load, fully compressed, without deformation or failure.

2.5 HOUSED-RESTRAINED-SPRING ISOLATORS

A. Freestanding, Steel, Open-Spring Isolators with Vertical-Limit Stop Restraint in Two-Part Telescoping Housing:

1. Two-Part Telescoping Housing: A steel top and bottom frame separated by an elastomeric material and enclosing the spring isolators. Housings are equipped with adjustable snubbers to limit vertical movement.

- a. Drilled base housing for bolting to structure with an elastomeric isolator pad attached to the underside. Bases shall limit floor load to 500 psig.
 - b. Threaded top housing with adjustment bolt and cap screw to fasten and level equipment.
2. Outside Spring Diameter: Not less than 80 percent of the compressed height of the spring at rated load.
 3. Minimum Additional Travel: 50 percent of the required deflection at rated load.
 4. Lateral Stiffness: More than 80 percent of rated vertical stiffness.
 5. Overload Capacity: Support 200 percent of rated load, fully compressed, without deformation or failure.

2.6 PIPE-RISER RESILIENT SUPPORT

- A. Description: All-directional, acoustical pipe anchor consisting of two steel tubes separated by a minimum 1/2-inch- thick neoprene.
 1. Vertical-Limit Stops: Steel and neoprene vertical-limit stops arranged to prevent vertical travel in both directions.
 2. Maximum Load Per Support: 500 psigon isolation material providing equal isolation in all directions.

2.7 RESILIENT PIPE GUIDES

- A. Description: Telescopic arrangement of two steel tubes or post and sleeve arrangement separated by a minimum 1/2-inch- thick neoprene.
 1. Factory-Set Height Guide with Shear Pin: Shear pin shall be removable and reinsertable to allow for selection of pipe movement. Guides shall be capable of motion to meet location requirements.

2.8 ELASTOMERIC HANGERS

- A. Elastomeric Mount in a Steel Frame with Upper and Lower Steel Hanger Rods:
 1. Frame: Steel, fabricated with a connection for an upper threaded hanger rod and an opening on the underside to allow for a maximum of 30 degrees of angular lower hanger-rod misalignment without binding or reducing isolation efficiency.
 2. Dampening Element: Molded, oil-resistant rubber, neoprene, or other elastomeric material with a projecting bushing for the underside opening preventing steel to steel contact.

2.9 SPRING HANGERS

- A. Combination Coil-Spring and Elastomeric-Insert Hanger with Spring and Insert in Compression:

1. Frame: Steel, fabricated for connection to threaded hanger rods and to allow for a maximum of 30 degrees of angular hanger-rod misalignment without binding or reducing isolation efficiency.
2. Outside Spring Diameter: Not less than 80 percent of the compressed height of the spring at rated load.
3. Minimum Additional Travel: 50 percent of the required deflection at rated load.
4. Lateral Stiffness: More than 80 percent of rated vertical stiffness.
5. Overload Capacity: Support 200 percent of rated load, fully compressed, without deformation or failure.
6. Elastomeric Element: Molded, oil-resistant rubber or neoprene. Steel-washer-reinforced cup to support spring and bushing projecting through bottom of frame.
7. Adjustable Vertical Stop: Steel washer with neoprene washer "up-stop" on lower threaded rod.
8. Self-centering hanger-rod cap to ensure concentricity between hanger rod and support spring coil.

2.10 RESTRAINT CHANNEL BRACINGS

- A. Description: MFMA-4, shop- or field-fabricated bracing assembly made of slotted steel channels with accessories for attachment to braced component at one end and to building structure at the other end and other matching components and with corrosion-resistant coating; rated in tension, compression, and torsion forces.

2.11 RESTRAINT CABLES

- A. Restraint Cables: ASTM A 603 galvanized steel cables. End connections made of steel assemblies with thimbles, brackets, swivel, and bolts designed for restraining cable service; with a minimum of two clamping bolts for cable engagement.

2.12 SEISMIC-RESTRAINT ACCESSORIES

- A. Hanger-Rod Stiffener: Steel tube or steel slotted-support-system sleeve with internally bolted connections Reinforcing steel angle clamped to hanger rod.
- B. Bushings for Floor-Mounted Equipment Anchor Bolts: Neoprene bushings designed for rigid equipment mountings, and matched to type and size of anchor bolts and studs.
- C. Bushing Assemblies for Wall-Mounted Equipment Anchorage: Assemblies of neoprene elements and steel sleeves designed for rigid equipment mountings, and matched to type and size of attachment devices used.
- D. Resilient Isolation Washers and Bushings: One-piece, molded, oil- and water-resistant neoprene, with a flat washer face.
- E. Mechanical Anchor Bolts: Drilled-in and stud-wedge or female-wedge type in zinc-coated steel for interior applications and stainless steel for exterior applications.

Select anchor bolts with strength required for anchor and as tested according to ASTM E 488.

PART 3 - EXECUTION

3.1 APPLICATIONS

- A. Multiple Pipe Supports: Secure pipes to trapeze member with clamps approved for application by an agency acceptable to authorities having jurisdiction.
- B. Hanger-Rod Stiffeners: Install hanger-rod stiffeners where indicated or scheduled on Drawings to receive them and where required to prevent buckling of hanger rods due to seismic forces.
- C. Strength of Support and Seismic-Restraint Assemblies: Where not indicated, select sizes of components so strength is adequate to carry present and future static and seismic loads within specified loading limits.

3.2 VIBRATION CONTROL AND SEISMIC-RESTRAINT DEVICE INSTALLATION

- A. Coordinate the location of embedded connection hardware with supported equipment attachment and mounting points and with requirements for concrete reinforcement and formwork specified in Section 03305 "Miscellaneous Cast-in-Place Concrete."
- B. Installation of vibration isolators must not cause any change of position of equipment, piping, or ductwork resulting in stresses or misalignment.
- C. Comply with requirements in Section 07720 "Roof Accessories" for installation of roof curbs, equipment supports, and roof penetrations.
- D. Equipment Restraints:
 - 1. Indicate type and quantity of snubbers described in first subparagraph below on Drawings or in the HVAC Vibration-Control and Seismic-Restraint Device Schedule on Drawings.
 - 2. Install resilient bolt isolation washers on equipment anchor bolts where clearance between anchor and adjacent surface exceeds 0.125 inch.
 - 3. Install seismic-restraint devices using methods approved by an agency acceptable to authorities having jurisdiction that provides required submittals for component.
- E. Piping Restraints:
 - 1. Comply with requirements in MSS SP-127.
 - 2. Space lateral supports a maximum of 40 feet o.c., and longitudinal supports a maximum of 40 feet.
 - 3. Brace a change of direction longer than 12 feet.

- F. Provide cables so they do not bend across edges of adjacent equipment or building structure.
- G. Provide seismic-restraint devices using methods approved by an agency acceptable to authorities having jurisdiction that provides required submittals for component.
- H. Provide bushing assemblies for anchor bolts for floor-mounted equipment, arranged to provide resilient media between anchor bolt and mounting hole in concrete base.
- I. Provide bushing assemblies for mounting bolts for wall-mounted equipment, arranged to provide resilient media where equipment or equipment-mounting channels are attached to wall.
- J. Attachment to Structure: If specific attachment is not indicated, anchor bracing to structure at flanges of beams, at upper truss chords of bar joists, or at concrete members.
- K. Drilled-in Anchors:
 - 1. Identify position of reinforcing steel and other embedded items prior to drilling holes for anchors. Do not damage existing reinforcing or embedded items during coring or drilling. Notify the structural engineer if reinforcing steel or other embedded items are encountered during drilling. Locate and avoid prestressed tendons, electrical and telecommunications conduit, and gas lines.
 - 2. Do not drill holes in concrete or masonry until concrete, mortar, or grout has achieved full design strength.
 - 3. Wedge Anchors: Protect threads from damage during anchor installation. Heavy-duty sleeve anchors shall be installed with sleeve fully engaged in the structural element to which anchor is to be fastened.
 - 4. Set anchors to manufacturer's recommended torque, using a torque wrench.
 - 5. Provide zinc-coated steel anchors for interior and stainless-steel anchors for exterior applications.

3.3 ACCOMMODATION OF DIFFERENTIAL SEISMIC MOTION

- A. Provide flexible connections in piping where they cross seismic joints, where adjacent sections or branches are supported by different structural elements, and where the connections terminate with connection to equipment that is anchored to a different structural element from the one supporting the connections as they approach equipment. Comply with requirements in Section 15180 "Hydronic Piping" for piping flexible connections.

3.4 FIELD QUALITY CONTROL

- A. Testing Agency: Engage a qualified testing agency to perform tests and inspections.
- B. Perform tests and inspections.
- C. Tests and Inspections:

1. Provide evidence of recent calibration of test equipment by a testing agency acceptable to authorities having jurisdiction.
 2. Schedule test with Owner, through Construction Manager, before connecting anchorage device to restrained component (unless postconnection testing has been approved), and with at least seven days' advance notice.
 3. Obtain Construction Manager's approval before transmitting test loads to structure. Provide temporary load-spreading members.
 4. Test at least four of each type and size of installed anchors and fasteners selected by Construction Manager.
 5. Test to 90 percent of rated proof load of device.
 6. Measure isolator restraint clearance.
 7. Measure isolator deflection.
 8. Verify snubber minimum clearances.
- D. Remove and replace malfunctioning units and retest as specified above.
- E. Prepare test and inspection reports.

3.5 ADJUSTING

- A. Adjust isolators after piping system is at operating weight.
- B. Adjust limit stops on restrained-spring isolators to mount equipment at normal operating height. After equipment installation is complete, adjust limit stops so they are out of contact during normal operation.

END OF SECTION

SECTION 15071HANGERS AND SUPPORTS FOR HVAC PIPING AND EQUIPMENT

PART 1 - GENERAL

1.1 SUMMARY

A. Section Includes:

1. Metal pipe hangers and supports.
2. Trapeze pipe hangers.
3. Thermal-hanger shield inserts.
4. Fastener systems.
5. Equipment supports.

1.2 PERFORMANCE REQUIREMENTS

- A. Delegated Design: Design trapeze pipe hangers and equipment supports, including comprehensive engineering analysis by a qualified professional engineer, using performance requirements and design criteria indicated.
- B. Structural Performance: Hangers and supports for HVAC piping and equipment shall withstand the effects of gravity loads and stresses within limits and under conditions indicated according to ASCE/SEI 7.
1. Design supports for multiple pipes capable of supporting combined weight of supported systems, system contents, and test water.
 2. Design equipment supports capable of supporting combined operating weight of supported equipment and connected systems and components.
 3. Design seismic-restraint hangers and supports for piping and equipment and obtain approval from authorities having jurisdiction.

1.3 ACTION SUBMITTALS

- A. Product Data: For each type of product indicated.
- B. Shop Drawings: Signed and sealed by a qualified professional engineer. Show fabrication and installation details and include calculations for the following; include Product Data for components:
1. Trapeze pipe hangers.
 2. Equipment supports.
- C. Delegated-Design Submittal: For trapeze hangers indicated to comply with performance requirements and design criteria, including analysis data signed and sealed by the qualified professional engineer responsible for their preparation.

1.4 INFORMATIONAL SUBMITTALS

- A. Welding certificates.

1.5 QUALITY ASSURANCE

- A. Structural Steel Welding Qualifications: Qualify procedures and personnel according to AWS D1.1/D1.1M, "Structural Welding Code - Steel."
- B. Pipe Welding Qualifications: Qualify procedures and operators according to ASME Boiler and Pressure Vessel Code.

PART 2 - PRODUCTS

2.1 METAL PIPE HANGERS AND SUPPORTS

- A. Carbon-Steel Pipe Hangers and Supports:

1. Description: MSS SP-58, Types 1 through 58, factory-fabricated components.
2. Galvanized Metallic Coatings: Pregalvanized or hot dipped.
3. Nonmetallic Coatings: Plastic coating, jacket, or liner.
4. Padded Hangers: Hanger with fiberglass or other pipe insulation pad or cushion to support bearing surface of piping.
5. Hanger Rods: Continuous-thread rod, nuts, and washer made of carbon steel.

- B. Stainless-Steel Pipe Hangers and Supports:

1. Description: MSS SP-58, Types 1 through 58, factory-fabricated components.
2. Padded Hangers: Hanger with fiberglass or other pipe insulation pad or cushion to support bearing surface of piping.
3. Hanger Rods: Continuous-thread rod, nuts, and washer made of stainless steel.

- C. Copper Pipe Hangers:

1. Description: MSS SP-58, Types 1 through 58, copper-coated-steel, factory-fabricated components.
2. Hanger Rods: Continuous-thread rod, nuts, and washer made of copper-coated steel.

2.2 TRAPEZE PIPE HANGERS

- A. Description: MSS SP-69, Type 59, shop- or field-fabricated pipe-support assembly made from structural carbon-steel shapes with MSS SP-58 galvanized carbon-steel hanger rods, nuts, saddles, and U-bolts.

2.3 THERMAL-HANGER SHIELD INSERTS

- A. Insulation-Insert Material for Hot Piping: ASTM C 591, Type VI, Grade 1 polyisocyanurate with 125-psi minimum compressive strength.
- B. For Trapeze or Clamped Systems: Insert and shield shall cover entire circumference of pipe.
- C. For Clevis Hangers: Insert and shield shall cover lower 180 degrees of pipe.
- D. Insert Length: Extend 2 inches beyond sheet metal shield for piping operating below ambient air temperature.

2.4 FASTENER SYSTEMS

- A. Powder-Actuated Fasteners: Threaded-steel stud, for use in hardened portland cement concrete with pull-out, tension, and shear capacities appropriate for supported loads and building materials where used.
- B. Mechanical-Expansion Anchors: Insert-wedge-type, zinc-coated anchors, for use in hardened portland cement concrete; with pull-out, tension, and shear capacities appropriate for supported loads and building materials where used.

2.5 EQUIPMENT SUPPORTS

- A. Description: Welded, shop- or field-fabricated equipment support made from structural galvanized carbon-steel shapes.

2.6 MISCELLANEOUS MATERIALS

- A. Structural Steel: ASTM A 36/A 36M, carbon-steel plates, shapes, and bars; galvanized.
- B. Grout: ASTM C 1107, factory-mixed and -packaged, dry, hydraulic-cement, nonshrink and nonmetallic grout; suitable for interior and exterior applications.
 - 1. Properties: Nonstaining, noncorrosive, and nongaseous.
 - 2. Design Mix: 5000-psi, 28-day compressive strength.

PART 3 - EXECUTION

3.1 HANGER AND SUPPORT INSTALLATION

- A. Metal Pipe-Hanger Installation: Comply with MSS SP-69 and MSS SP-89. Install hangers, supports, clamps, and attachments as required to properly support piping from the building structure.

- B. Metal Trapeze Pipe-Hanger Installation: Comply with MSS SP-69 and MSS SP-89. Arrange for grouping of parallel runs of horizontal piping, and support together on field-fabricated trapeze pipe hangers.
 - 1. Pipes of Various Sizes: Support together and space trapezes for smallest pipe size or install intermediate supports for smaller diameter pipes as specified for individual pipe hangers.
 - 2. Field fabricate from ASTM A 36/A 36M, galvanized carbon-steel shapes selected for loads being supported. Weld steel according to AWS D1.1/D1.1M.
- C. Thermal-Hanger Shield Installation: Install in pipe hanger or shield for insulated piping.
- D. Fastener System Installation:
 - 1. Install powder-actuated fasteners for use in lightweight concrete or concrete slabs less than 4 inches thick in concrete after concrete is placed and completely cured. Use operators that are licensed by powder-actuated tool manufacturer. Install fasteners according to powder-actuated tool manufacturer's operating manual.
 - 2. Install mechanical-expansion anchors in concrete after concrete is placed and completely cured. Install fasteners according to manufacturer's written instructions.
- E. Provide hangers and supports complete with necessary attachments, inserts, bolts, rods, nuts, washers, and other accessories.
- F. Equipment Support Installation: Fabricate from welded-structural-steel shapes, galvanized.
- G. Provide hangers and supports to allow controlled thermal and seismic movement of piping systems, to permit freedom of movement between pipe anchors, and to facilitate action of expansion joints, expansion loops, expansion bends, and similar units.
- H. Provide lateral bracing with pipe hangers and supports to prevent swaying and seismic restraint.
- I. Provide building attachments within concrete slabs or attach to structural steel. Install additional attachments at concentrated loads, including valves, flanges, and strainers, NPS 2-1/2 and larger and at changes in direction of piping. Install concrete inserts before concrete is placed; fasten inserts to forms and install reinforcing bars through openings at top of inserts.
- J. Load Distribution: Install hangers and supports so that piping live and dead loads and stresses from movement will not be transmitted to connected equipment.
- K. Pipe Slopes: Install hangers and supports to provide indicated pipe slopes and to not exceed maximum pipe deflections allowed by ASME B31.9 for building services piping.

L. Insulated Piping:

1. Attach clamps and spacers to piping.
 - a. Piping Operating above Ambient Air Temperature: Clamp may project through insulation.
 - b. Piping Operating below Ambient Air Temperature: Use thermal-hanger shield insert with clamp sized to match OD of insert.
 - c. Do not exceed pipe stress limits allowed by ASME B31.9 for building services piping.
2. Provide MSS SP-58, Type 39, protection saddles if insulation without vapor barrier is indicated. Fill interior voids with insulation that matches adjoining insulation.
 - a. Option: Thermal-hanger shield inserts may be used. Include steel weight-distribution plate for pipe NPS 4 and larger if pipe is installed on rollers.
3. Provide MSS SP-58, Type 40, protective shields on cold piping with vapor barrier. Shields shall span an arc of 180 degrees.
 - a. Option: Thermal-hanger shield inserts may be used. Include steel weight-distribution plate for pipe NPS 4 and larger if pipe is installed on rollers.
4. Shield Dimensions for Pipe: Not less than the following:
 - a. NPS 1/4 to NPS 3: 12 inches long and 0.048 inch thick.
5. Thermal-Hanger Shields: Install with insulation same thickness as piping insulation.

3.2 EQUIPMENT SUPPORTS

- A. Fabricate structural-steel stands to suspend equipment from structure overhead or to support equipment above floor.
- B. Grouting: Place grout under supports for equipment and make bearing surface smooth, and level.
- C. Provide lateral bracing, to prevent swaying, for equipment supports.

3.3 METAL FABRICATIONS

- A. Cut, drill, and fit miscellaneous metal fabrications for trapeze pipe hangers and equipment supports.
- B. Fit exposed connections together to form hairline joints. Field weld connections that cannot be shop welded because of shipping size limitations.

- C. Field Welding: Comply with AWS D1.1/D1.1M procedures for shielded, metal arc welding; appearance and quality of welds; and methods used in correcting welding work; and with the following:
1. Use materials and methods that minimize distortion and develop strength and corrosion resistance of base metals.
 2. Obtain fusion without undercut or overlap.
 3. Remove welding flux immediately.
 4. Finish welds at exposed connections so no roughness shows after finishing and so contours of welded surfaces match adjacent contours.

3.4 ADJUSTING

- A. Hanger Adjustments: Adjust hangers to distribute loads equally on attachments and to achieve indicated slope of pipe.
- B. Trim excess length of continuous-thread hanger and support rods to 1-1/2 inches.

3.5 PAINTING

- A. Galvanized Surfaces: Clean welds, bolted connections, and abraded areas and apply galvanizing-repair paint to comply with ASTM A 780.

3.6 HANGER AND SUPPORT SCHEDULE

- A. Specific hanger and support requirements are in Sections specifying piping systems and equipment.
- B. Comply with MSS SP-69 for pipe-hanger selections and applications that are not specified in piping system Sections.
- C. Provide hangers and supports with galvanized metallic coatings for piping and equipment that will not have field-applied finish.
- D. Provide nonmetallic coatings on attachments for electrolytic protection where attachments are in direct contact with copper tubing.
- E. Provide galvanized carbon-steel pipe hangers and supports and metal trapeze pipe hangers and attachments for general service applications.
- F. Provide copper-plated pipe hangers and copper or stainless-steel attachments for copper piping and tubing.
- G. Provide padded hangers for piping that is subject to scratching.
- H. Provide thermal-hanger shield inserts for insulated piping and tubing.
- I. Horizontal-Piping Hangers and Supports: Unless otherwise indicated and except as specified in piping system Sections, provide the following types:

1. Adjustable, Steel Clevis Hangers (MSS Type 1): For suspension of noninsulated or insulated, stationary pipes NPS 1/2 to NPS 4.
 2. Carbon- or Alloy-Steel, Double-Bolt Pipe Clamps (MSS Type 3): For suspension of pipes NPS 3/4 to NPS 4, requiring clamp flexibility and up to 4 inches of insulation with restraint clips.
 3. U-Bolts (MSS Type 24): For support of heavy pipes NPS 1/2 to NPS 4.
 4. Pipe Saddle Supports (MSS Type 36): For support of pipes NPS 4 to NPS 4, with steel-pipe base stanchion support and cast-iron floor flange or carbon-steel plate.
 5. Pipe Stanchion Saddles (MSS Type 37): For support of pipes NPS 4 and larger, with steel-pipe base stanchion support and cast-iron floor flange or carbon-steel plate, and with U-bolt to retain pipe.
- J. Vertical-Piping Clamps: Unless otherwise indicated and except as specified in piping system Sections, provide the following types:
1. Extension Pipe or Riser Clamps (MSS Type 8): For support of pipe risers NPS 3/4 to NPS 24.
 2. Carbon- or Alloy-Steel Riser Clamps (MSS Type 42): For support of pipe risers NPS 3/4 to NPS 24 if longer ends are required for riser clamps.
- K. Hanger-Rod Attachments: Unless otherwise indicated and except as specified in piping system Sections, provide the following types:
1. Steel Turnbuckles (MSS Type 13): For adjustment up to 6 inches for heavy loads galvanized.
 2. Steel Clevises (MSS Type 14): For 120 to 450 deg F piping installations, galvanized.
- L. Building Attachments: Unless otherwise indicated and except as specified in piping system Sections, provide the following types:
1. Top-Beam C-Clamps (MSS Type 19): For use under roof installations with bar-joint construction, to attach to top flange of structural shape with restraint clips.
 2. Side-Beam or Channel Clamps (MSS Type 20): For attaching to bottom flange of beams, channels, or angles with restraint clips.
 3. Center-Beam Clamps (MSS Type 21): For attaching to center of bottom flange of beams.
 4. Welded Beam Attachments (MSS Type 22): For attaching to bottom of beams if loads are considerable and rod sizes are large with restraint clips.
 5. C-Clamps (MSS Type 23): For structural shapes.
 6. Welded-Steel Brackets: For support of pipes from below, or for suspending from above by using clip and rod. Use one of the following for indicated loads:
 - a. Light (MSS Type 31): 750 lb.
 - b. Medium (MSS Type 32): 1500 lb.
 - c. Heavy (MSS Type 33): 3000 lb.
 7. Side-Beam Brackets (MSS Type 34): For sides of steel with restraint clips..

8. Plate Lugs (MSS Type 57): For attaching to steel beams if flexibility at beam is required.
- M. Saddles and Shields: Unless otherwise indicated and except as specified in piping system Sections, provide the following types:
1. Steel-Pipe-Covering Protection Saddles (MSS Type 39): To fill interior voids with insulation that matches adjoining insulation.
 2. Protection Shields (MSS Type 40): Of length recommended in writing by manufacturer to prevent crushing insulation.
 3. Thermal-Hanger Shield Inserts: For supporting insulated pipe.
- N. Spring Hangers and Supports: Unless otherwise indicated and except as specified in piping system Sections, provide the following types:
1. Spring Cushions (MSS Type 48): For light loads if vertical movement does not exceed 1-1/4 inches.
 2. Spring-Cushion Roll Hangers (MSS Type 49): For equipping Type 41, roll hanger with springs.
 3. Variable-Spring Base Supports (MSS Type 52): Preset to indicated load and limit variability factor to 25 percent to allow expansion and contraction of piping system from base support.
- O. Comply with MSS SP-69 for trapeze pipe-hanger selections and applications that are not specified in piping system Sections.
- P. Use mechanical-expansion anchors instead of building attachments where required in concrete construction.

END OF SECTION

SECTION 15110

BALL VALVES FOR HVAC PIPING

PART 1 - GENERAL

1.1 SUMMARY

A. Section Includes:

1. Bronze ball valves.

1.2 ACTION SUBMITTALS

A. Product Data: For each type of valve.

PART 2 - PRODUCTS

2.1 GENERAL REQUIREMENTS FOR VALVES

A. Source Limitations for Valves: Obtain each type of valve from single source from single manufacturer.

B. ASME Compliance:

1. ASME B1.20.1 for threads for threaded-end valves.
2. ASME B16.10 and ASME B16.34 for ferrous valve dimensions and design criteria.
3. ASME B16.18 for solder-joint connections.
4. ASME B31.9 for building services piping valves.

C. Bronze valves shall be made with dezincification-resistant materials. Bronze valves made with copper alloy (brass) containing more than 15 percent zinc are not permitted.

D. Refer to HVAC valve schedule articles for applications of valves.

E. Valve Pressure-Temperature Ratings: Not less than indicated and as required for system pressures and temperatures.

F. Valve Sizes: Same as upstream piping unless otherwise indicated.

G. Valve Actuator Types:

1. Handlever: For quarter-turn valves smaller than NPS 4.

H. Valves in Insulated Piping:

1. Include 2-inch stem extensions.

2. Extended operating handle of nonthermal-conductive material, and protective sleeves that allow operation of valves without breaking the vapor seals or disturbing insulation.
3. Memory stops that are fully adjustable after insulation is applied.

I. Valve Bypass and Drain Connections: MSS SP-45.

2.2 BRONZE BALL VALVES

A. Two-Piece Bronze Ball Valves with Full Port and Stainless-Steel Trim:

1. Description:
 - a. Standard: MSS SP-110.
 - b. SWP Rating: 150 psig.
 - c. CWP Rating: 600 psig.
 - d. Body Design: Two piece.
 - e. Body Material: Bronze.
 - f. Ends: Threaded.
 - g. Seats: PTFE.
 - h. Stem: Stainless steel.
 - i. Ball: Stainless steel, vented.
 - j. Port: Full.

PART 3 - EXECUTION

3.1 VALVE INSTALLATION

- A. Provide valves for Hot water and chilled water piping systems with unions or flanges at each piece of equipment arranged to allow service, maintenance, and equipment removal without system shutdown.
- B. Locate valves for easy access and provide separate support where necessary.
- C. Provide valves in horizontal piping with stem at or above center of pipe.
- D. Provide valves in position to allow full stem movement.

3.2 GENERAL REQUIREMENTS FOR VALVE APPLICATIONS

- A. If valves with specified SWP classes or CWP ratings are unavailable, the same types of valves with higher SWP classes or CWP ratings may be substituted.
- B. Select valves with the following end connections:
 1. For Copper Tubing, NPS 2 and Smaller: Threaded ends except where solder-joint valve-end option is indicated in valve schedules below.

2. For Steel Piping, NPS 2 and Smaller: Threaded ends.
3. For Steel Piping, NPS 2-1/2", and larger. Flanged connections.

3.3 HEATING-WATER VALVE SCHEDULE

- A. Pipe sizes NPS 2 inches and Smaller: Two piece, port, or bronze with stainless-steel trim.
 1. Valves may be provided with solder-joint ends instead of threaded ends.

END OF SECTION

SECTION 15120

EXPANSION FITTINGS AND LOOPS FOR HVAC PIPING

PART 1 - GENERAL

1.1 SUMMARY

- A. Application for hot water piping, and hot water coil pumps.
- B. Section Includes:
 - 1. Metal, compensator packless expansion joints.
 - 2. Flexible-hose packless expansion joints.
 - 3. Alignment guides and anchors.
 - 4. Pipe loops and swing connections.

1.2 ACTION SUBMITTALS

- A. Product Data: For each type of product.
- B. Delegated-Design Submittal: For each anchor and alignment guide, including analysis data, signed and sealed by the qualified professional engineer responsible for their preparation.
 - 1. Design Calculations: Calculate requirements for thermal expansion of piping systems and for selecting and designing expansion joints, loops, and swing connections.
 - 2. Anchor Details: Detail fabrication of each anchor indicated. Show dimensions and methods of assembly and attachment to building structure.
 - 3. Alignment Guide Details: Detail field assembly and attachment to building structure.
 - 4. Schedule: Indicate type, manufacturer's number, size, material, pressure rating, end connections, and location for each expansion joint.

1.3 INFORMATIONAL SUBMITTALS

- A. Welding certificates.

1.4 CLOSEOUT SUBMITTALS

- A. Maintenance data.

1.5 QUALITY ASSURANCE

- A. Welding Qualifications: Qualify procedures and personnel according to AWS D1.1/D1.1M, "Structural Welding Code - Steel."
- B. Pipe and Pressure-Vessel Welding Qualifications: Qualify procedures and operators according to ASME Boiler and Pressure Vessel Code.

PART 2 - PRODUCTS

2.1 PERFORMANCE REQUIREMENTS

- A. Compatibility: Products shall be suitable for piping service fluids, materials, working pressures, and temperatures.
- B. Capability: Products to absorb 200 percent of maximum axial movement between anchors.

2.2 PACKLESS EXPANSION JOINTS

- A. Metal, Compensator Packless Expansion Joints:
 1. Minimum Pressure Rating: 175 psig, unless otherwise indicated.
 2. Description: Totally enclosed, externally pressurized, multi-ply bellows isolated from fluid flow by an internal pipe sleeve and external housing.
 3. Joint Axial Movement: 2 inches of compression and 1/2 inch of extension.
 4. Configuration for Copper Tubing: Multi-ply, phosphor-bronze bellows with copper pipe ends.
 - a. End Connections for Copper Tubing NPS 2 and Smaller: threaded.
 - b. End Connections for Copper Tubing NPS 2-1/2 to NPS 4: Flanged.
 5. Configuration for Steel Piping: Multi-ply, stainless-steel bellows; steel-pipe end connections; and carbon-steel shroud.
 - a. End Connections for Steel Pipe NPS 2 and Smaller: Threaded.
 - b. End Connections for Steel Pipe NPS 2-1/2 to NPS 4: Flanged, or Welded.
- B. Flexible-Hose Packless Expansion Joints:
 1. Description: Manufactured assembly with inlet and outlet elbow fittings and two flexible-metal-hose legs joined by long-radius, 180-degree return bend or center section of flexible hose.
 2. Flexible Hose: Corrugated-metal inner hoses and braided outer sheaths.
 3. Expansion Joints for Copper Tubing NPS 2 and Smaller: Copper-alloy fittings with Threaded end connections.

- a. Bronze hoses and single-braid bronze sheaths with 450 psig at 70 deg F and 340 psig at 450 deg F ratings.
4. Stainless-steel hoses and single-braid, stainless-steel sheaths with 300 psig at 70 deg F and 225 psig at 450 deg F ratings.
5. Expansion Joints for Steel Piping NPS 2 and Smaller: Carbon-steel fittings with threaded end connections.
 - a. Stainless-steel hoses and single-braid, stainless-steel sheaths with 450 psig at 70 deg F and 325 psig at 600 deg ratings.

2.3 ALIGNMENT GUIDES AND ANCHORS

A. Alignment Guides:

1. Description: Steel, factory-fabricated alignment guide, with bolted two-section outer cylinder and base for attaching to structure; with two-section guiding slider for bolting to pipe.

B. Anchor Materials:

1. Steel Shapes and Plates: ASTM A 36/A 36M.
2. Bolts and Nuts: ASME B18.10 or ASTM A 183, steel hex head.
3. Washers: ASTM F 844, steel, plain, flat washers.
4. Mechanical Fasteners: Insert-wedge-type stud with expansion plug anchor for use in hardened portland cement concrete, with tension and shear capacities appropriate for application.
 - a. Stud: Threaded, zinc-coated carbon steel.
 - b. Expansion Plug: Zinc-coated steel.
 - c. Washer and Nut: Zinc-coated steel.
5. Chemical Fasteners: Insert-type stud, bonding-system anchor for use with hardened portland cement concrete, with tension and shear capacities appropriate for application.
 - a. Bonding Material: ASTM C 881/C 881M, Type IV, Grade 3, two-component epoxy resin suitable for surface temperature of hardened concrete where fastener is to be installed.
 - b. Stud: ASTM A 307, zinc-coated carbon steel with continuous thread on stud, unless otherwise indicated.
 - c. Washer and Nut: Zinc-coated steel.

PART 3 - EXECUTION

3.1 EXPANSION JOINT INSTALLATION

- A. Install expansion joints of sizes matching sizes of piping in which they are installed.
- B. Install packed-type expansion joints with packing suitable for fluid service.
- C. Install metal-bellows expansion joints according to EJMA's "Standards of the Expansion Joint Manufacturers Association, Inc."

3.2 PIPE LOOP AND SWING CONNECTION INSTALLATION

- A. Provide pipe loops cold-sprung in tension or compression as required to partly absorb tension or compression produced during anticipated change in temperature.
- B. Connect risers and branch connections to mains with at least five pipe fittings, including tee in main.
- C. Connect risers and branch connections to terminal units with at least four pipe fittings, including tee in riser.
- D. Connect mains and branch connections to terminal units with at least four pipe fittings, including tee in main.

3.3 ALIGNMENT-GUIDE AND ANCHOR INSTALLATION

- A. Provide alignment guides to guide expansion and to avoid end-loading and torsional stress.
- B. Provide two guide(s) on each side of pipe expansion fittings and loops. Install guides nearest to expansion joint not more than four pipe diameters from expansion joint.
- C. Attach guides to pipe, and secure guides to building structure.
- D. Provide anchors at locations to prevent stresses from exceeding those permitted by ASME B31.9 and to prevent transfer of loading and stresses to connected equipment.
- E. Anchor Attachments:
 - 1. Anchor Attachment to Steel Pipe: Attach by welding. Comply with ASME B31.9 and ASME Boiler and Pressure Vessel Code: Section IX, "Welding and Brazing Qualifications."
 - 2. Anchor Attachment to Copper Tubing: Attach with pipe hangers. Use MSS SP-69, Type 24; U bolts bolted to anchor.
- F. Fabricate and install steel anchors by welding steel shapes, plates, and bars. Comply with ASME B31.9 and AWS D1.1/D1.1M.

1. Anchor Attachment to Steel Structural Members: Attach by welding.
 2. Anchor Attachment to Concrete Structural Members: Attach by fasteners. Follow fastener manufacturer's written instructions.
- G. Use grout to form flat bearing surfaces for guides and anchors attached to concrete.

END OF SECTION

SECTION 15130

HYDRONIC PUMPS

PART 1 - GENERAL

1.1 SUMMARY

A. Section Includes:

1. Closed-coupled, in-line centrifugal pumps for Hot Water Boilers, and HW piping system.
2. Close-coupled, in-line centrifugal pumps: HW coil Pumps, freeze protection
3. Automatic condensate pump units.

1.2 ACTION SUBMITTALS

A. Product Data: For each type of pump.

B. Shop Drawings: For each pump.

1. Show pump layout and connections and include piping layout with boilers, hydraulic specialty equipment, pumps, supports, isolation valves, and control valves.
2. Performance requirements: Provide hydraulic calculations for proposed piping configuration, boilers equipment, pumps and piping layout. Provide
3. Include diagrams for power, signal, and control wiring.

1.3 CLOSEOUT SUBMITTALS

A. Operation and maintenance data.

PART 2 - PRODUCTS

2.1 CLOSE-COUPLED, IN-LINE CENTRIFUGAL PUMPS

A. Manufacturers: Provide products from the following:

1. Taco
2. Paco
3. ITT-Bell & Gossett (Basis of Design)
4. Or Approved Equal

- B. Description: Factory-assembled and -tested, centrifugal, overhung-impeller, close-coupled, in-line pump as defined in HI 1.1-1.2 and HI 1.3; designed for installation with pump and motor shafts mounted horizontally or vertically.
- C. Pump Construction:
1. Casing: Radially split, cast iron, with threaded gage tappings at inlet and outlet, replaceable bronze wear rings, and threaded, or companion-flange connections.
 2. Impeller: ASTM B 584, cast bronze; statically and dynamically balanced, keyed to shaft, and secured with a locking cap screw. For constant-speed pumps, trim impeller to match specified performance.
 3. Pump Shaft: Stainless steel.
 4. Seal: Packing seal consisting of stuffing box with a minimum of four rings of graphite-impregnated braided yarn with bronze lantern ring between center two graphite rings, and bronze packing gland.
 5. Pump Bearings: Oil lubricated; bronze-journal or thrust type
- D. Motor: Single speed and rigidly mounted to pump casing.
1. Electrical Components, Devices, and Accessories: Listed and labeled as defined in NFPA 70, by a qualified testing agency, and marked for intended location and application.
 2. Single speed motors shall be provided for Boiler HW pumps, and freeze protection pumps.
 3. Comply with NEMA designation, temperature rating, service factor, and efficiency requirements for motors specified in Section 15700 "Common Motor Requirements for HVAC Equipment".
 - a. Enclosure: Open, drip-proof.
 - b. Motor Bearings: Permanently lubricated ball bearings.
 - c. Unusual Service Conditions:
 - 1) Ambient Temperature: 0 deg F.
 - 2) Altitude: sea level.
 - 3) High humidity.
 - d. Efficiency: Premium efficient. If Project has more than one type or configuration of close-coupled, in-line centrifugal pump, delete "Capacities and Characteristics" Paragraph below and schedule pumps on Drawings.
 - e. Mechanical contractor shall supply motor starters, and installed by electrical contractor.
- E. Motor: Motors for Secondary HW Pumps with variable speed shall include variable frequency drives, VFD'S, and supplied by the mechanical contractor. The electrical contractor shall install and wire accordingly.

- F. Pump Capacities and Characteristics: Refer to the drawings for pump capacity information.

2.2 AUTOMATIC CONDENSATE PUMP UNITS

- A. Manufacturers: Provide products from the following:
 - 1. Aspen
 - 2. Little Giant
 - 3. Beckett
 - 4. Or Approved Equal
- B. Description: Packaged units with corrosion-resistant pump, plastic tank with cover, and automatic controls. Include factory- or field-installed check valve and a 72-inch-minimum, electrical power cord with plug.
- C. Capacities and Characteristics: Refer to the drawings.

PART 3 - EXECUTION

3.1 PUMP INSTALLATION

- A. Comply with HI 1.4.
- B. Install pumps to provide access for periodic maintenance including removing motors, VFD's, impellers, couplings, and accessories.
- C. Independently support pumps and piping so weight of piping is not supported by pumps and weight of pumps is not supported by piping. Provide flexible connectors on the suction and discharge of the pumps for flexibility.
- D. Automatic Condensate Pump Units: Install units for collecting condensate and extend to open drain.
- E. Equipment Mounting:
 - 1. Comply with requirements for vibration isolation and seismic control devices specified in Section 15070 "Vibration and Seismic Controls for HVAC".
- F. Equipment Mounting: Install in-line pumps with continuous-thread hanger rods and spring hangers of size required to support weight of in-line pumps.
 - 1. Comply with requirements for seismic-restraint devices specified in Section 15070 "Vibration and Seismic Controls for HVAC".

3.2 ALIGNMENT

- A. Engage a factory-authorized service representative to perform alignment service.

- B. Comply with requirements in Hydronics Institute standards for alignment of pump and motor shaft. Add shims to the motor feet and bolt motor to base frame. Do not use grout between motor feet and base frame.
- C. Comply with pump and coupling manufacturers' written instructions.

3.3 CONNECTIONS

- A. Drawings indicate general arrangement of hot water piping, fittings, and specialties.
- B. Where installing piping adjacent to pump, allow space for service and maintenance.
- C. Connect piping to pumps. Install valves that are same size as piping connected to pumps.
- D. Install suction and discharge pipe sizes equal to or greater than diameter of pump nozzles.
- E. Provide check valve and throttling valves with memory stop on discharge side of pumps.
- F. Provide balancing valves at discharge of all heating hot water pumps for balancing to required hot water flows.
- G. Provide Y-type strainer and shutoff valve on suction side of all pumps.
- H. Provide flexible connectors on suction and discharge sides of pumps between pump casing and valves.
- I. Install pressure gages on pump suction and discharge or at integral pressure-gage tapping, or install single gage with multiple-input selector valve.
- J. Install check valve and ball valve on each condensate pump unit discharge.
- K. Ground equipment according to Section 16450 "Grounding and Bonding for Electrical Systems".
- L. Connect wiring according to Section 16120 "Low-Voltage Electrical Power Conductors and Cables".

END OF SECTION

SECTION 15180

HYDRONIC PIPING

PART 1 - GENERAL

1.1 SUMMARY

- A. Section includes pipe and fitting materials and joining methods for the following:
1. Hot-water heating piping.
 2. Makeup-water piping.
 3. Condensate-drain piping.
 4. Boiler safety valve piping
 5. Boiler drain piping

1.2 RELATED SECTIONS

1. Refer to underground hot water piping spec section 15190 Underground Hydronic Piping, for copper pipe, plastic pipe in casing, and 10 inch underground casing piping.
2. Refer to spec section 15000 for additional submittal requirements.
3. Refer to spec sections 15071, Hangers and Supports for HVAC Piping and Equipment.
4. Refer to spec Section 15130 Hydronic Pumps.

1.3 ACTION SUBMITTALS

- A. Product Data: For pipe, fittings and joining materials.
- B. Provide shop drawings for the entire hot water piping layout of the hydronic piping system including valves, boilers, pumps, hydronic specialty equipment, and all branch piping to the equipment.
- C. Provide hydraulic calculations for complete HW piping system with equipment for sizing pumps and equipment.
- D. Delegated-Design Submittal:
1. Design calculations and detailed fabrication and assembly of pipe anchors and alignment guides, hangers and supports for multiple pipes, expansion joints and loops, and attachments of the same to the building structure.
 2. Locations of pipe anchors and alignment guides, seismic restraints, and expansion joints and loops.
 3. Locations of and details for penetrations, including sleeves and sleeve seals for exterior walls, floors, basement, and foundation walls.

4. Locations of and details for penetration and fire stopping for fire- and smoke-rated wall and floor and ceiling assemblies.

1.4 INFORMATIONAL SUBMITTALS

- A. Field quality-control reports.

1.5 QUALITY ASSURANCE

- A. ASME Compliance: Comply with ASME B31.9, "Building Services Piping," for materials, products, and installation.

PART 2 - PRODUCTS

2.1 PERFORMANCE REQUIREMENTS

- A. Hydronic piping components and installation shall be capable of withstanding the following minimum working pressure and temperature unless otherwise indicated:
 1. Hot-Water Heating Piping: Maximum working pressure is 50 PSIG, pressure at 200 deg F.
 2. Makeup-Water Piping: 80 psig at 150 deg F.
 3. Coil Condensate-Drain Piping: 60 deg F/ (max)
 4. Boiler piping: 50 PSIG, safety valve set at 75 psig.

2.2 COPPER TUBE AND FITTINGS

- A. Drawn-Temper Copper Tubing: ASTM B 88, Type L.
- B. DWV Copper Tubing: ASTM B 306, Type DWV. Used for drainage, soldered/brazed joints.
- C. Wrought-Copper Unions: ASME B16.22.

2.3 STEEL PIPE AND FITTINGS

- A. Steel Pipe: ASTM A 53/A 53M, black steel with plain ends; welded and seamless, Grade B, Schedule 40 for aboveground, and schedule 80 for underground service, and wall thickness as indicated in "Piping Applications" Article.

2.4 JOINING MATERIALS

- A. Pipe-Flange Gasket Materials: Suitable for chemical and thermal conditions of piping system contents.

1. ASME B16.21, nonmetallic, flat, asbestos free, 1/8-inch maximum thickness unless otherwise indicated.
 - a. Full-Face Type: For flat-face, Class 125, cast-iron and cast-bronze flanges.
- B. Flange Bolts and Nuts: ASME B18.2.1, carbon steel, unless otherwise indicated.
- C. Solder Filler Metals: ASTM B 32, lead-free alloys. Include water-flushable flux according to ASTM B 813.
- D. Brazing Filler Metals: AWS A5.8/A5.8M, BCuP Series, copper-phosphorus alloys for joining copper with copper; or BAg-1, silver alloy for joining copper with bronze or steel.
- E. Welding Filler Metals: Comply with AWS D10.12M/D10.12 for welding materials appropriate for wall thickness and chemical analysis of steel pipe being welded.
- F. Gasket Material: Thickness, material, and type suitable for fluid to be handled and working temperatures and pressures.

2.5 DIELECTRIC FITTINGS

- A. General Requirements: Assembly of copper alloy and ferrous materials with separating nonconductive insulating material. Include end connections compatible with pipes to be joined.
- B. Dielectric Unions:
 1. Description:
 - a. Standard: ASSE 1079.
 - b. Pressure Rating: 125 psig minimum at 180 deg F End Connections: Solder-joint copper alloy and threaded ferrous.

PART 3 - EXECUTION

3.1 PIPING APPLICATIONS

- A. Hot-water heating piping, aboveground, NPS 2 and smaller, shall be the following:
 1. Type L, drawn-temper copper tubing, wrought-copper fittings, and brazed joints.
- B. Hot-water heating piping, aboveground, NPS 2-1/2 and larger, shall be the following:
 1. Schedule 40 steel pipe; ASTM A53/53M, black steel with plain beveled ends, welded and seamless, Grade B.
- C. Boiler hot water piping for safety valves: shall be

1. Schedule 40 steel pipe, size to be same size connection of safety valve.
- D. Makeup-water piping installed aboveground shall be the following:
1. Type L, drawn-temper copper tubing, wrought-copper fittings, and brazed joints.
- E. Coil Condensate-Drain Piping: Type DWV, drawn-temper copper tubing, wrought-copper fittings, and soldered joints.

3.2 PIPING INSTALLATIONS

- A. Drawing plans, schematics, and diagrams indicate general location and arrangement of piping systems. Install piping as indicated unless deviations to layout are approved on Coordination Drawings.
- B. Provide piping in concealed locations unless otherwise indicated and except in equipment rooms and service areas.
- C. Provide piping indicated to be exposed and piping in equipment rooms and service areas at right angles or parallel to building walls. Diagonal runs are prohibited.
- D. Provide piping above accessible ceilings to allow sufficient space for ceiling panel removal.
- E. Provide piping to permit valve servicing.
- F. Provide piping at indicated slopes for draining of piping systems.
- G. Provide piping free of sags and bends.
- H. Provide fittings for changes in direction and branch connections.
- I. Provide piping to allow application of insulation.
- J. Select system components with pressure rating equal to or greater than system operating pressure.
- K. Provide groups of pipes parallel to each other, spaced to permit applying insulation and servicing of valves.
- L. Provide low point drains, consisting of a tee fitting, NPS 3/4 ball valve, and short NPS 3/4 threaded nipple with cap, at low points in piping system mains and elsewhere as required for system drainage.
- M. Provide piping at a uniform grade of 0.2 percent upward in direction of flow.
- N. Provide pipe sizes using eccentric reducer fitting installed with level side up.

- O. Provide branch connections to mains using mechanically formed tee fittings in main pipe, with the branch connected to the bottom of the main pipe. For up-feed risers, connect the branch to the top of the main pipe. Provide at least 3- legs of piping for each branch connection for flexibility.
- P. Provide at least 3-legs of piping for connecting supply and return connections at equipment.
- Q. Provide valves according to Section 15110 "Ball Valves for HVAC Piping".
- R. Provide unions in piping, NPS and smaller, adjacent to valves, at final connections of equipment, and elsewhere as indicated.
- S. Provide flanges in piping, NPS 2-1/2 and larger, at final connections of equipment and elsewhere as indicated.
- T. Provide shutoff valve immediately upstream of each dielectric fitting.
- U. Provide High Point Vents (auto type) in piping for removing air in lines. Drain auto HP Vents to plumbing fixtures drain (air gap).
- V. Comply with requirements in Section 15120 "Expansion Fittings and Loops for HVAC Piping" for installation of expansion loops, expansion joints, anchors, and pipe alignment guides.
- W. Comply with requirements in Section 15000 "Identification for HVAC Piping and Equipment" for identifying piping.
- X. Provide sleeves for piping penetrations of walls, ceilings, and floors. Comply with requirements for sleeves specified in Section 15000 "Sleeves and Sleeve Seals for HVAC Piping".
- Y. Provide sleeve seals for piping penetrations of concrete walls and slabs. Comply with requirements for sleeve seals specified in Section 15000 "Sleeves and Sleeve Seals for HVAC Piping".
- Z. Provide escutcheons for piping penetrations of walls, ceilings, and floors. Comply with requirements for escutcheons specified in Section 15000 "Escutcheons for HVAC Piping".

3.3 DIELECTRIC FITTING INSTALLATION

- A. Provide dielectric fittings in piping at connections of dissimilar metal piping and tubing.
- B. Dielectric Fittings for NPS 2 and Smaller: Use dielectric unions.

3.4 HANGERS AND SUPPORTS

- A. Comply with requirements in Section 15071 "Hangers and Supports for HVAC Piping and Equipment" for hanger, support, and anchor devices. Comply with the following requirements for maximum spacing of supports.
- B. Comply with requirements in Section 15070 "Vibration and Seismic Controls for HVAC" for seismic restraints.
- C. Provide the following pipe attachments:
 - 1. Adjustable steel clevis hangers for individual horizontal piping less than 20 feet long.
 - 2. Trapeze hangers and spring hangers for multiple horizontal piping 20 feet or longer.
 - 3. Pipe Roller: MSS SP-58, Type 44 or pipe shields for multiple horizontal piping 20 feet or longer, supported on a trapeze.
 - 4. Spring hangers to support vertical runs.
 - 5. Provide copper-clad hangers and supports for hangers and supports in direct contact with copper pipe.
- D. Provide hangers for steel piping with the following maximum spacing and minimum rod sizes:
 - 1. NPS 3/4: Maximum span, 7 feet.
 - 2. NPS 1: Maximum span, 7 feet.
 - 3. NPS 1-1/2: Maximum span, 9 feet.
 - 4. NPS 2: Maximum span, 10 feet.
 - 5. NPS 2-1/2: Maximum span, 11 feet.
 - 6. NPS 3 and Larger: Maximum span, 12 feet.
- E. Provide hangers for drawn-temper copper piping with the following maximum spacing and minimum rod sizes:
 - 1. NPS 3/4: Maximum span, 5 feet; minimum rod size, 1/4 inch.
 - 2. NPS 1: Maximum span, 6 feet; minimum rod size, 1/4 inch.
 - 3. NPS 1-1/4: Maximum span, 7 feet; minimum rod size, 3/8 inch.
 - 4. NPS 1-1/2: Maximum span, 8 feet; minimum rod size, 3/8 inch.
 - 5. NPS 2: Maximum span, 8 feet; minimum rod size, 3/8 inch.
 - 6. NPS 2-1/2: Maximum span, 9 feet; minimum rod size, 3/8 inch.
 - 7. NPS 3 and Larger: Maximum span, 10 feet; minimum rod size, 3/8 inch.
- F. Support vertical runs at roof, at each floor, and at 10-foot intervals between floors.

3.5 PIPE JOINT CONSTRUCTION

- A. Ream ends of pipes and tubes and remove burrs. Bevel plain ends of steel pipe.
- B. Remove scale, slag, dirt, and debris from inside and outside of pipe and fittings before assembly.

- C. Soldered Joints: Apply ASTM B 813, water-flushable flux, unless otherwise indicated, to tube end. Construct joints according to ASTM B 828 or CDA's "Copper Tube Handbook," using lead-free solder alloy complying with ASTM B 32.
- D. Brazed Joints: Construct joints according to AWS's "Brazing Handbook," "Pipe and Tube" Chapter, using copper-phosphorus brazing filler metal complying with AWS A5.8/A5.8M.
- E. Threaded Joints: Thread pipe with tapered pipe threads according to ASME B1.20.1. Cut threads full and clean using sharp dies. Ream threaded pipe ends to remove burrs and restore full ID. Join pipe fittings and valves as follows:
 - 1. Apply appropriate tape or thread compound to external pipe threads unless dry seal threading is specified.
 - 2. Damaged Threads: Do not use pipe or pipe fittings with threads that are corroded or damaged. Do not use pipe sections that have cracked or open welds.
- F. Flanged Joints: Select appropriate gasket material, size, type, and thickness for service application. Install gasket concentrically positioned. Use suitable lubricants on bolt threads.
- G. Welded joints: Hot water piping with carbon steel pipe, 2-1/2 and larger shall be welded construction.

3.6 TERMINAL EQUIPMENT CONNECTIONS

- A. Sizes for HW supply and return piping connections shall be the same as or larger than equipment connections.
- B. Provide control valves in accessible locations close to connected equipment.
- C. Provide bypass piping with globe valve and isolation valve ball valves around control valve including HW circulating freeze protection pump. If parallel control valves are installed, only one bypass is required.
- D. Provide ports for pressure gages and thermometers at coil inlet and outlet connections.

3.7 FIELD QUALITY CONTROL

- A. Prepare hydronic piping according to ASME B31.9 and as follows:
 - 1. Leave joints, including welds, uninsulated and exposed for examination during test.
 - 2. Provide temporary restraints for expansion joints that cannot sustain reactions due to test pressure. If temporary restraints are impractical, isolate expansion joints from testing.
 - 3. Flush hydronic piping systems with clean water; then remove and clean or replace strainer screens.

4. Isolate equipment from piping. If a valve is used to isolate equipment, its closure shall be capable of sealing against test pressure without damage to valve. Install blinds in flanged joints to isolate equipment.
 5. Install safety valve, set at a pressure no more than one-third higher than test pressure, to protect against damage by expanding liquid or other source of overpressure during test.
- B. Perform the following tests on hydronic piping:
1. Use ambient temperature water as a testing medium unless there is risk of damage due to freezing. Another liquid that is safe for workers and compatible with piping may be used.
 2. While filling system, use vents installed at high points of system to release air. Use drains installed at low points for complete draining of test liquid.
 3. Isolate expansion tanks and determine that hydronic system is full of water.
 4. Subject piping system to hydrostatic test pressure that is not less than 1.5 times the system's working pressure. Test pressure shall not exceed maximum pressure for any vessel, pump, valve, or other component in system under test. Verify that stress due to pressure at bottom of vertical runs does not exceed 90 percent of specified minimum yield strength or 1.7 times the "SE" value in Appendix A in ASME B31.9, "Building Services Piping."
 5. After hydrostatic test pressure has been applied for at least 10 minutes, examine piping, joints, and connections for leakage. Eliminate leaks by tightening, repairing, or replacing components, and repeat hydrostatic test until there are no leaks.
 6. Prepare written report of testing.
- C. Perform the following before operating the system:
1. Open manual valves fully.
 2. Inspect pumps for proper rotation.
 3. Set makeup pressure-reducing valves for required system pressure.
 4. Inspect air vents at high points of system and determine if all are installed and operating freely (automatic type), or bleed air completely (manual type).
 5. Set temperature controls so all coils are calling for full flow.
 6. Inspect and set operating temperatures of hydronic equipment, such as boilers, hydronic specialty equipment (air separator, expansion tank, etc.) to specified values.
 7. Verify lubrication of motors and bearings.

END OF SECTION

SECTION 15181

REFRIGERANT PIPING

PART 1 - GENERAL

1.1 SUMMARY

A. Section Includes:

1. Refrigerant pipes and fittings.
2. Refrigerant piping valves and specialties.
3. Refrigerants.
4. Casing piping system.

1.2 ACTION SUBMITTALS

A. Product Data: For each type of valve and refrigerant piping specialty.

B. Shop Drawings:

1. Show piping size and piping layout, including oil traps, double suction risers, specialties, and pipe and tube sizes to accommodate, as a minimum, equipment provided, elevation difference between compressor and evaporator, and length of piping to ensure proper operation and compliance with warranties of connected equipment.
2. Show interface and spatial relationships between piping and equipment.
3. Shop Drawing Scale: 1/4 inch equals 1 foot.

1.3 INFORMATIONAL SUBMITTALS

A. Field quality-control reports.

1.4 CLOSEOUT SUBMITTALS

A. Operation and Maintenance Data: For refrigerant valves and piping specialties to include in maintenance manuals.

1.5 QUALITY ASSURANCE

A. Comply with ASHRAE 15, "Safety Code for Refrigeration Systems."

B. Comply with ASME B31.5, "Refrigeration Piping and Heat Transfer Components."

PART 2 - PRODUCTS

2.1 PERFORMANCE REQUIREMENTS

- A. Line Test Pressure for Refrigerant R-407C, or R-410A.:
 - 1. Suction Lines for Air-Conditioning Applications: 230 psig.
 - 2. Suction Lines for Heat-Pump Applications: 380 psig.
 - 3. Hot-Gas and Liquid Lines: 380 psig.
- B. Line Test Pressure for Refrigerant R-410A:
 - 1. Suction Lines for Air-Conditioning Applications: 300 psig.
 - 2. Suction Lines for Heat-Pump Applications: 535 psig.
 - 3. Hot-Gas and Liquid Lines: 535 psig.

2.2 COPPER TUBE AND FITTINGS

- A. Copper Tube: ASTM B 280, Type ACR.
- B. Wrought-Copper Fittings: ASME B16.22.
- C. Wrought-Copper Unions: ASME B16.22.
- D. Solder Filler Metals: ASTM B 32. Use 95-5 tin antimony or alloy HB solder to join copper socket fittings on copper pipe (Low pressure lines, only).
- E. Brazing Filler Metals: AWS A5.8/A5.8M.
- F. Flexible Connectors:
 - 1. Body: Tin-bronze bellows with woven, flexible, tinned-bronze-wire-reinforced protective jacket.
 - 2. End Connections: Socket ends.
 - 3. Offset Performance: Capable of minimum 3/4-inch misalignment in minimum 7-inch- long assembly.
 - 4. Working Pressure Rating: Factory test at minimum 500 psig.
Maximum Operating Temperature: 250 deg F.

2.3 CASING PIPE, PVC, UNDERGROUND PIPING

- A. Casing Piping for routed underground and areaway refrigerant piping.
 - 1. Pipe: ASTM D 1785, Schedules 80, plain ends as indicated in "Piping Application" Article.
 - 2. Pipe Fittings: Socket-type pipe fittings, ASTM D 2466 for Schedule 40 pipe; ASTM D 2467 for Schedule 80 pipe.
 - 3. Solvent Cements: ASTM D 2564. Include primer according to ASTM F 656.

Use PVC solvent cement that has a VOC content of 510 g/L or less when calculated according to 40 CFR 59, Subpart D (EPA Method 24).

- a. Use adhesive primer that has a VOC content of 550 g/L or less when calculated according to 40 CFR 59, Subpart D (EPA Method 24).

2.4 VALVES AND SPECIALTIES

A. Diaphragm Packless Valves:

1. Body and Bonnet: Forged brass or cast bronze; globe design with straight-through or angle pattern.
2. Diaphragm: Phosphor bronze and stainless steel with stainless-steel spring.
3. Operator: Rising stem and hand wheel.
4. Seat: Nylon.
5. End Connections: Socket, union, or flanged.
6. Working Pressure Rating: 500 psig.
7. Maximum Operating Temperature: 275 deg F.

B. Packed-Angle Valves:

1. Body and Bonnet: Forged brass or cast bronze.
2. Packing: Molded stem, back seating, and replaceable under pressure.
3. Operator: Rising stem.
4. Seat: Nonrotating, self-aligning polytetrafluoroethylene.
5. Seal Cap: Forged-brass or valox hex cap.
6. End Connections: Socket, union, threaded, or flanged.
7. Working Pressure Rating: 500 psig.
8. Maximum Operating Temperature: 275 deg F.

C. Check Valves:

1. Body: Ductile iron, forged brass, or cast bronze; globe pattern.
2. Bonnet: Bolted ductile iron, forged brass, or cast bronze; or brass hex plug.
3. Piston: Removable polytetrafluoroethylene seat.
4. Closing Spring: Stainless steel.
5. Manual Opening Stem: Seal cap, plated-steel stem, and graphite seal.
6. End Connections: Socket, union, threaded, or flanged.
7. Maximum Opening Pressure: 0.50 psig.
8. Working Pressure Rating: 500 psig.
9. Maximum Operating Temperature: 275 deg F.

D. Service Valves:

1. Body: Forged brass with brass cap including key end to remove core.
2. Core: Removable ball-type check valve with stainless-steel spring.
3. Seat: Polytetrafluoroethylene.
4. End Connections: Copper spring.
5. Working Pressure Rating: 500 psig.

- E. Solenoid Valves: Comply with AHRI 760 and UL 429; listed and labeled by a National Recognized Testing Laboratory (NRTL).
1. Body and Bonnet: Plated steel.
 2. Solenoid Tube, Plunger, Closing Spring, and Seat Orifice: Stainless steel.
 3. Seat: Polytetrafluoroethylene.
 4. End Connections: Socket, threaded, union.
 5. Electrical: Molded, watertight coil in NEMA 250 enclosure of type required by location with 1/2-inch conduit adapter, and verify voltage available
 6. Working Pressure Rating: 400 psig.
 7. Maximum Operating Temperature: 240 deg F.
- F. Safety Relief Valves: Comply with 2010 ASME Boiler and Pressure Vessel Code; listed and labeled by an NRTL.
1. Body and Bonnet: Ductile iron and steel, with neoprene O-ring seal.
 2. Piston, Closing Spring, and Seat Insert: Stainless steel.
 3. Seat: Polytetrafluoroethylene.
 4. End Connections: Threaded.
 5. Working Pressure Rating: 400 psig.
 6. Maximum Operating Temperature: 240 deg F.
- G. Thermostatic Expansion Valves: Comply with AHRI 750.
1. Body, Bonnet, and Seal Cap: Forged brass or steel.
 2. Diaphragm, Piston, Closing Spring, and Seat Insert: Stainless steel.
 3. Packing and Gaskets: Non-asbestos.
 4. Capillary and Bulb: Copper tubing filled with refrigerant charge.
 5. Suction Temperature: 40 deg F.
 6. Superheat: Adjustable.
 7. Reverse-flow option (for heat-pump applications).
 8. End Connections: Socket, flare, or threaded union.
 9. Working Pressure Rating: 700 psig.
- H. Straight-Type Strainers:
1. Body: Welded steel with corrosion-resistant coating.
 2. Screen: 100-mesh stainless steel.
 3. End Connections: Socket, flare, or threaded.
 4. Working Pressure Rating: 500 psig.
 5. Maximum Operating Temperature: 275 deg F.
- I. Angle-Type Strainers:
1. Body: Forged brass or cast bronze.
 2. Drain Plug: Brass hex plug.
 3. Screen: 100-mesh monel.
 4. End Connections: Socket, flare or threaded.
 5. Working Pressure Rating: 500 psig.
 6. Maximum Operating Temperature: 275 deg F.

J. Moisture/Liquid Indicators:

1. Body: Forged brass.
2. Window: Replaceable, clear, fused glass window with indicating element protected by filter screen.
3. Indicator: Color coded to show moisture content in parts per million (ppm).
4. Minimum Moisture Indicator Sensitivity: Indicate moisture above 60 ppm.
5. End Connections: Socket or flare.
6. Working Pressure Rating: 500 psig.
7. Maximum Operating Temperature: 240 deg F.

K. Replaceable-Core Filter Dryers: Comply with AHRI 730.

1. Body and Cover: Painted-steel shell with ductile-iron cover, stainless-steel screws, and neoprene gaskets.
2. Filter Media: 10 micron, pleated with integral end rings; stainless-steel support.
3. Desiccant Media: alumina.
4. Designed for reverse flow (for heat-pump applications).
5. End Connections: Socket.
6. Access Ports: NPS 1/4 connections at entering and leaving sides for pressure differential measurement.
7. Maximum Pressure Loss: 2 psig.
8. Rated Flow
9. Working Pressure Rating: 500 psig.
10. Maximum Operating Temperature: 240 deg F.

L. Permanent Filter Dryers: Comply with AHRI 730.

1. Body and Cover: Painted-steel shell.
2. Filter Media: 10 micron, pleated with integral end rings; stainless-steel support.
3. Desiccant Media: Activated alumina.
4. Designed for reverse flow (for heat-pump applications).
5. End Connections: Socket.
6. Access Ports: NPS 1/4 connections at entering and leaving sides for pressure differential measurement.
7. Maximum Pressure Loss: 2 psig.
8. Rated Flow:
9. Working Pressure Rating: 500 psig.
10. Maximum Operating Temperature: 240 deg F.

2.5 REFRIGERANTS

- A. R-407C: Difluoromethane/Pentafluoroethane/1,1,1,2-Tetrafluoroethane.
- B. R-410A: Pentafluoroethane/Difluoromethane.

PART 3 - EXECUTION

3.1 PIPING APPLICATIONS FOR REFRIGERANT R-407C

- A. Suction Lines: Copper, Type ACR, annealed-temper tubing and wrought-copper fittings with brazed joints.
- B. Safety-Relief-Valve Discharge Piping: Copper, Type ACR, drawn-temper tubing and wrought-copper fittings with threaded joints.

3.2 PIPING APPLICATIONS FOR REFRIGERANT R-410A

- A. Suction Lines: Copper, Type ACR, annealed-temper tubing and wrought-copper fittings with brazed joints.
- B. Safety-Relief-Valve Discharge Piping: Copper, Type ACR, annealed- or drawn-temper tubing and wrought-copper fittings with brazed joints, or threaded.

3.3 VALVE AND SPECIALTY APPLICATIONS

- A. Provide diaphragm packless valves in suction and discharge lines of compressor.
- B. Provide service valves for gage taps at inlet and outlet of hot-gas bypass valves and strainers if they are not an integral part of valves and strainers.
- C. Provide a check valve at the compressor discharge and a liquid accumulator at the compressor suction connection.
- D. Except as otherwise indicated, provide diaphragm pack less or packed-angle valves on inlet and outlet side of filter dryers, based on size and capacity.
- E. Provide a full-size, three-valve bypass around filter dryers.
- F. Provide solenoid valves upstream from each expansion valve and hot-gas bypass valve. Install solenoid valves in horizontal lines with coil at top.
- G. Provide thermostatic expansion valves as close as possible to distributors on evaporators.
 - 1. Provide valve so diaphragm case is warmer than bulb.
 - 2. Secure bulb to clean, straight, horizontal section of suction line using two bulb straps. Do not mount bulb in a trap or at bottom of the line.
 - 3. If external equalizer lines are required, make connection where it will reflect suction-line pressure at bulb location.
- H. Provide safety relief valves where required by 2010 ASME Boiler and Pressure Vessel Code. Pipe safety-relief-valve discharge line to outside according to ASHRAE 15.

- I. Provide moisture/liquid indicators in liquid line at the inlet of the thermostatic expansion valve or at the inlet of the evaporator coil capillary tube.
- J. Provide strainers upstream from and adjacent to the following unless they are furnished as an integral assembly for the device being protected:
 - 1. Solenoid valves.
 - 2. Thermostatic expansion valves.
 - 3. Hot-gas bypass valves.
 - 4. Compressor.
- K. Provide filter dryers in liquid line between compressor and thermostatic expansion valve, and in the suction line at the compressor.
- L. Provide receivers sized to accommodate pump-down charge.
- M. Provide flexible connectors at compressors.

3.4 PIPING INSTALLATION

- A. Drawing plans, schematics, and diagrams indicate general location and arrangement of piping systems; indicated locations and arrangements were used to size pipe and calculate friction loss, expansion, pump sizing, and other design considerations. Install piping as indicated unless deviations to layout are approved on Shop Drawings.
- B. Provide refrigerant piping according to ASHRAE 15.
- C. Install piping in concealed locations unless otherwise indicated and except in equipment rooms and service areas.
- D. Provide piping indicated to be exposed and piping in equipment rooms and service areas at right angles or parallel to building walls. Diagonal runs are prohibited unless specifically indicated otherwise.
- E. Provide piping above accessible ceilings to allow sufficient space for ceiling panel removal.
- F. Provide piping adjacent to machines to allow service and maintenance.
- G. Provide piping free of sags and bends.
- H. Provide fittings for changes in direction and branch connections.
- I. Select system components with pressure rating equal to or greater than system operating pressure.
- J. Refer to Section 15920 "Direct Digital Control (DDC) System for HVAC", control wiring, and sequence of operation.

- K. Provide piping as short and direct as possible, with a minimum number of joints, elbows, and fittings.
- L. Arrange piping to allow inspection and service of refrigeration equipment. Install valves and specialties in accessible locations to allow for service and inspection. Install access doors or panels as specified in Section 15000 "Supplemental General Mechanical Requirements" if valves or equipment requiring maintenance is concealed behind finished surfaces.
- M. Provide refrigerant piping in protective casing piping where installed belowground. Provide minimum 8' PVC, schedule 80 casing pipe, utilize mostly 45 deg standard elbows, and long sweep elbows. Do not use standard 90 deg elbows. Provide flanges where necessary for future removal of sections in the in the areaway. Contractor shall verify 8" PVC, or larger is sufficient to provide the required casing for the carrier refrigerant piping. Seal all open ends with weatherproofing materials.
- N. Refrigerant liquid and suction lines, insulated, shall be pulled through the PVC piping, or layed in sections as required. Provide shop drawings of the entire layout of piping for engineer's approval.
- O. Provide refrigerant piping in rigid or flexible conduit in locations where exposed to mechanical injury.
- P. Slope refrigerant piping as follows:
 - 1. Install horizontal hot-gas discharge piping with a uniform slope downward away from compressor.
 - 2. Install horizontal suction lines with a uniform slope downward to compressor.
 - 3. Install traps and double risers to entrain oil in vertical runs.
 - 4. Liquid lines may be installed level.
- Q. When brazing or soldering, remove solenoid-valve coils and sight glasses; also remove valve stems, seats, and packing, and accessible internal parts of refrigerant specialties. Do not apply heat near expansion-valve bulb.
- R. Provide piping with adequate clearance between pipe and adjacent walls and hangers or between pipes for insulation installation.
- S. Identify refrigerant piping and valves according to Section 15000 "Identification for HVAC Piping and Equipment".
- T. Provide sleeves for piping penetrations of walls, ceilings, and floors. Comply with requirements for sleeves specified in Section 15000 "Sleeves and Sleeve Seals for HVAC Piping".
- U. Provide sleeve seals for piping penetrations of concrete walls and slabs. Comply with requirements for sleeve seals specified in Section 15000 "Sleeves and Sleeve Seals for HVAC Piping".

- V. Provide escutcheons for piping penetrations of walls, ceilings, and floors. Comply with requirements for escutcheons specified in Section 15000 "Escutcheons for HVAC Piping".

3.5 PIPE JOINT CONSTRUCTION

- A. Ream ends of pipes and tubes and remove burrs.
- B. Remove scale, slag, dirt, and debris from inside and outside of pipe and fittings before assembly.
- C. Soldered Joints: Construct joints according to ASTM B 828 or CDA's "Copper Tube Handbook."
- D. Brazed Joints: Construct joints according to AWS's "Brazing Handbook," Chapter "Pipe and Tube."
 - 1. Use Type BCuP (copper-phosphorus) alloy for joining copper socket fittings with copper pipe.
 - 2. Use Type BAg (cadmium-free silver) alloy for joining copper with bronze or steel.
- E. Solvent Joints for PVC Piping.: ASTM D 2564.

3.6 HANGERS AND SUPPORTS

- A. Comply with requirements for pipe hangers and supports specified in Section 15071 "Hangers and Supports for HVAC Piping and Equipment".
- B. Provide the following pipe attachments:
 - 1. Adjustable steel clevis hangers for individual horizontal runs less than 20 feet long.
 - 2. Roller hangers and spring hangers for individual horizontal runs 20 feet or longer.
 - 3. Pipe Roller: MSS SP-58, Type 44 for multiple horizontal piping 20 feet or longer, supported on a trapeze.
 - 4. Spring hangers to support vertical runs.
 - 5. Copper-clad hangers and supports for hangers and supports in direct contact with copper pipe.
- C. Provide hangers for copper tubing with the following maximum spacing and minimum rod diameters:
 - 1. NPS 1/2: Maximum span, 60 inches; minimum rod, 1/4 inch.
 - 2. NPS 5/8: Maximum span, 60 inches; minimum rod, 1/4 inch.
 - 3. NPS 1: Maximum span, 72 inches; minimum rod, 1/4 inch.
 - 4. NPS 1-1/4: Maximum span, 72 inches; minimum rod, 3/8 inch.
 - 5. NPS 1-1/2: Maximum span, 72 inches; minimum rod, 3/8 inch.
 - 6. NPS 2: Maximum span, 96 inches; minimum rod, 3/8 inch.

- D. Support multifloor vertical runs at least at each floor.

3.7 FIELD QUALITY CONTROL

- A. Perform the following tests and inspections:

1. Comply with ASME B31.5, Chapter VI.
2. Test refrigerant piping, specialties, and receivers. Isolate compressor, condenser, evaporator, and safety devices from test pressure if they are not rated above the test pressure.
3. Test high- and low-pressure side piping of each system separately at not less than the pressures indicated in "Performance Requirements" Article.
 - a. Fill system with nitrogen to the required test pressure.
 - b. System shall maintain test pressure at the manifold gage throughout duration of test.
 - c. Test joints and fittings with electronic leak detector or by brushing a small amount of soap and glycerin solution over joints.
 - d. Remake leaking joints using new materials, and retest until satisfactory results are achieved.

- B. Prepare test and inspection reports.

3.8 SYSTEM CHARGING

- A. Charge system using the following procedures:

1. Provide core in filter dryers after leak test but before evacuation.
2. Evacuate entire refrigerant system with a vacuum pump to 500 micrometers. If vacuum holds for 12 hours, system is ready for charging.
3. Break vacuum with refrigerant gas, allowing pressure to build up to 2 psig.
4. Charge system with a new filter-dryer core in charging line.

3.9 ADJUSTING

- A. Adjust thermostatic expansion valve to obtain proper evaporator superheat.
- B. Adjust high- and low-pressure switch settings to avoid short cycling in response to fluctuating suction pressure.
- C. Adjust set-point temperature of air-conditioning controllers to the system design temperature.
- D. Perform the following adjustments before operating the refrigeration system, according to manufacturer's written instructions:
 1. Open shutoff valves in condenser water circuit.
 2. Verify that compressor oil level is correct.

3. Open compressor suction and discharge valves.
 4. Open refrigerant valves except bypass valves that are used for other purposes.
 5. Check open compressor-motor alignment and verify lubrication for motors and bearings.
- E. Replace core of replaceable filter dryer after system has been adjusted and after design flow rates and pressures are established.

END OF SECTION

SECTION 15185

HYDRONIC PIPING SPECIALTIES

PART 1 - GENERAL

1.1 SUMMARY

A. Section includes special-duty valves and specialties for the following:

1. Hot-water heating piping.
2. Makeup-water piping.
3. Condensate-drain piping.
4. Air-vent piping.
5. Expansion Tank
6. Air Separator

1.2 ACTION SUBMITTALS

A. Product Data: For each type of the following:

1. Valves: Include flow and pressure drop curves based on manufacturer's testing for calibrated-orifice balancing valves and automatic flow-control valves.
2. Air-control devices.
3. Hydronic specialties.

1.3 Delegated Design: Provide design calculations for sizing of expansion tank along with shop drawings of the piping layout

1.4 CLOSEOUT SUBMITTALS

A. Operation and maintenance data.

1.5 QUALITY ASSURANCE

A. ASME Compliance: Safety valves and pressure vessels shall bear the appropriate ASME label. Fabricate and stamp air separators and expansion tanks to comply with ASME Boiler and Pressure Vessel Code: Section VIII, Division 1.

PART 2 - PRODUCTS

2.1 PERFORMANCE REQUIREMENTS

- A. Hydronic piping components and installation shall be capable of withstanding the following maximum working pressure of 50 psig and temperature unless otherwise indicated:
1. Hot-Water Heating Piping: 200 deg F.
 2. Boiler hot water piping, 50 PSIG
 3. Makeup-Water Piping: verify pressure at 150 deg F.
 4. Coil Condensate-Drain Piping: 60 deg F.
 5. Safety-Valve-Inlet and -Outlet Piping: Equal to the pressure of the piping system to which it is attached.

2.2 VALVES

- A. Ball Valves: Comply with requirements specified in Section 15110 "Ball Valves for HVAC Piping".
- B. Automatic Temperature-Control Valves, Actuators, and Sensors: Comply with requirements specified in Section 15920 "Direct Digital Control (DDC) System for HVAC".
- C. Bronze, Calibrated-Orifice, Balancing Valves:
1. Body: Bronze, ball or plug type with calibrated orifice or venturi.
 2. Ball: stainless steel.
 3. Plug: Resin.
 4. Seat: PTFE.
 5. End Connections: Threaded or socket.
 6. Pressure Gage Connections: Integral seals for portable differential pressure meter.
 7. Handle Style: Lever, with memory stop to retain set position.
 8. CWP Rating: Minimum 125 psig.
 9. Maximum Operating Temperature: 250 deg F.
- D. Diaphragm-Operated, Pressure-Reducing Valves: ASME labeled.
1. Body: Bronze or brass.
 2. Disc: Glass and carbon-filled PTFE.
 3. Seat: Brass.
 4. Stem Seals: EPDM O-rings.
 5. Diaphragm: EPT.
 6. Low inlet-pressure check valve.
 7. Inlet Strainer: removable without system shutdown.
 8. Valve Seat and Stem: Noncorrosive.

9. Valve Size, Capacity, and Operating Pressure: Selected to suit system in which installed, with operating pressure and capacity factory set and field adjustable.
- E. Diaphragm-Operated Safety Valves: ASME labeled.
1. Body: Bronze or brass.
 2. Disc: Glass and carbon-filled PTFE.
 3. Seat: Brass.
 4. Stem Seals: EPDM O-rings.
 5. Diaphragm: EPT.
 6. Wetted, Internal Work Parts: Brass and rubber.
 7. Inlet Strainer: removable without system shutdown.
 8. Valve Seat and Stem: Noncorrosive.
 9. Valve Size, Capacity, and Operating Pressure: Comply with ASME Boiler and Pressure Vessel Code: Section IV, and selected to suit system in which installed, with operating pressure and capacity factory set and field adjustable.
- F. Automatic Flow-Control Valves:
1. Body: Brass or ferrous metal.
 2. Piston and Spring Assembly: Stainless steel, tamper proof, self-cleaning, and removable.
 3. Combination Assemblies: Include bronze or brass-alloy ball valve.
 4. Identification Tag: Marked with zone identification, valve number, and flow rate.
 5. Size: Same as pipe in which installed.
 6. Performance: Maintain constant flow, plus or minus 5 percent over system pressure fluctuations.
 7. Minimum CWP Rating: 175 psig.
 8. Maximum Operating Temperature: 200 deg F.

2.3 AIR-CONTROL DEVICES

- A. Automatic Air Vents for new HW piping systems:
1. Body: Bronze.
 2. Internal Parts: Nonferrous.
 3. Operator: Screwdriver or thumbscrew.
 4. Inlet Connection: NPS 1/2 (DN 15).
 5. Discharge Connection: NPS 1/8 (DN 6).
 6. CWP Rating: 150 psig.
 7. Maximum Operating Temperature: 225 deg F.
- B. Air Separators:
1. Air Separator Tank: Provide new air separator for the new HW piping system including AHU'S, FCU's, unit heaters, cabinet unit heaters, HW pumps. One-piece steel tank with an integral weir constructed to decelerate system flow to

maximize air separation. Provide tank as noted on the drawings schedule with 4" flanged inlet/outlet connections. Provide connections for expansion tank and drain.

2. Provide connection for make-up water as required.
3. Maximum Working Pressure: Up to 175 psig.
4. Maximum Operating Temperature: Up to 300 deg F.

2.4 HYDRONIC PIPING SPECIALTIES

A. Y-Pattern Strainers:

1. Body: ASTM A 126, Class B, cast iron with bolted cover and bottom drain connection.
2. End Connections: Threaded ends for NPS 2 (DN 50) and smaller; flanged ends for NPS 2-1/2 (DN 65) and larger.
3. Strainer Screen: Stainless-steel, 60-mesh strainer, or perforated stainless-steel basket.
4. CWP Rating: 125 psig.

B. Stainless-Steel Bellow, Flexible Connectors:

1. Body: Stainless-steel bellows with woven, flexible, bronze, wire-reinforcing protective jacket.
2. End Connections: Threaded or flanged to match equipment connected.
3. Performance: Capable of 3/4-inch (20-mm) misalignment.
4. CWP Rating: 150 psig (1035 kPa).
5. Maximum Operating Temperature: 250 deg F (121 deg C).

C. Expansion Tank: Provide bladder type expansion tank, sized for entire piping system volume, rated from 60 deg F to maximum of 200 deg F.

D. In-Air Separators: provide in-line separators for pump suction and equipment, as noted on the drawings.

E. Expansion Fittings: Comply with requirements in Section 15120 "Expansion Fittings and Loops for HVAC Piping".

PART 3 - EXECUTION

3.1 VALVE APPLICATIONS

- A. Provide shut-off-duty valves at each branch connection to supply and return mains, and at supply connection to each piece of equipment.
- B. Provide calibrated-orifice, balancing valves at each branch connection to return main, and as indicated on the drawings.

- C. Provide calibrated-orifice, balancing valves in the return pipe of each heating or cooling terminal.
- D. Provide check valves at each HW circulation pump discharge, and elsewhere as required to control flow direction.
- E. Provide safety valves at hot-water boilers and elsewhere as required (if not already installed in the main systems) by ASME Boiler and Pressure Vessel Code. Install pipe from the safety valves to nearest floor drain or as indicated on Drawings. Comply with ASME Boiler and Pressure Vessel Code: Section VIII, Division 1, for installation requirements.
- F. Provide pressure-reducing valves at makeup-water connection to regulate system fill pressure.

3.2 HYDRONIC SPECIALTIES INSTALLATION

- A. Provide manual air vents at high points in piping, at heat-transfer coils, and elsewhere as required for system air venting. Provide auto air vent and pipe to drain, as noted on the drawings.
- B. Provide in-line air separator in new HW pump suction. Install drain valve on air separators.
- C. Provide main air separator with 4" inlet/outlet connections. Install and connect Make-up water system with control valve and pressure reducing valve. Install drain an expansion tank connection.
- D. Provide expansion tank in the HW piping system, and shall be sized by vendor of expansion tank based on the actual system volume. The contractor shall determine the volume of the existing HW system.
 - 1. Install tank fittings that are shipped loose.
 - 2. Support tank from floor or structure above with sufficient strength to carry weight of tank, piping connections, fittings, plus tank full of water. Do not overload building components and structural members.
- E. Vent and purge air from hydronic systems, and ensure that expansion tank is properly charged with air to suit system Project requirements.

END OF SECTION

SECTION 15190

UNDERGROUND HYDRONIC PIPING

PART 1 - GENERAL

1.1 SUMMARY

- A. Section Includes:
1. Copper tube and fittings.
 2. Steel pipes and fittings.
 3. Polyethylene plastic pipe and fittings.
 4. Transition fittings.
 5. Casing piping system.

1.2 PERFORMANCE REQUIREMENTS

- A. Provide components and installation capable of producing hydronic piping systems with the following minimum working-pressure ratings:
1. Hot-Water Piping: 100 psig (690 kPa) at 200 deg F (93 deg C). Copper pipe, and PEX flexible plastic tubing for underground piping.
- B. Product Data: For the following:
1. Casing piping.
 - a. PVC, Schedule 80, installed between the pits of Toll Booths and to the tunnel. This material will not interfere with underground traffic sensors.
- C. Shop Drawings: For underground hydronic piping. Signed and sealed by a professional engineer.
1. Calculate requirements for expansion compensation for underground piping.
 2. Show expansion compensators, offsets, and loops with appropriate materials to allow piping movement in the required locations. Show anchors and guides that restrain piping movement with calculated loads, and show concrete thrust block dimensions.
 3. Show pipe sizes, locations, and elevations. Show piping in trench, conduit, and cased pipe with details showing clearances between piping, and show insulation thickness.

1.3 INFORMATIONAL SUBMITTALS

- A. Material Test Reports: For casing piping.

- B. Source quality-control reports.
- C. Field quality-control reports.

1.4 QUALITY ASSURANCE

- A. ASME Compliance: Comply with ASME B31.9, "Building Services Piping," for materials, products, and installation.

PART 2 - PRODUCTS

2.1 COPPER TUBE AND FITTINGS

- A. Drawn-Temper Copper Tubing: ASTM B 88, Type L (ASTM B 88M, Type B).
- B. Wrought-Copper Fittings: ASME B16.22.
- C. Wrought-Copper Unions: ASME B16.22.
- D. Solder Filler Metals: ASTM B 32, lead-free alloys. Include water-flushable flux according to ASTM B 813.
- E. Brazing Filler Metals: AWS A5.8/A5.8M, BCuP Series, copper-phosphorus alloys for joining copper with copper; or BAg-1, silver alloy for joining copper with bronze or steel.

2.2 PLASTIC PIPE AND FITTINGS

- A. Polyethylene Plastic (PEX Flex, or approved equal):
 - 1. Pipe: ASTM F 441/F 441M, Schedules 40 and 80, plain ends as indicated in "Piping Application" Article.
 - 2. Pipe Fittings: Socket-type pipe fittings, ASTM F 438 for Schedule 40 pipe; ASTM F 439 for Schedule 80 pipe.
 - 3. Solvent Cements: ASTM F 493.
 - a. Use Polyethylene solvent cement that has a VOC content of 490 g/L or less when calculated according to 40 CFR 59, Subpart D (EPA Method 24).
 - b. Use adhesive primer that has a VOC content of 550 g/L or less when calculated according to 40 CFR 59, Subpart D (EPA Method 24).
- B. PVC Plastic- 10" Casing Pipe:
 - 1. Pipe: ASTM D 1785, Schedules 80, plain ends as indicated in "Piping Application" Article.

2. Pipe Fittings: Socket-type pipe fittings, ASTM D 2466 for Schedule 40 pipe; ASTM D 2467 for Schedule 80 pipe.
3. Solvent Cements: ASTM D 2564. Include primer according to ASTM F 656.
 - a. Use PVC solvent cement that has a VOC content of 510 g/L or less when calculated according to 40 CFR 59, Subpart D (EPA Method 24).
 - b. Use adhesive primer that has a VOC content of 550 g/L or less when calculated according to 40 CFR 59, Subpart D (EPA Method 24).
- C. Plastic, Pipe-Flange Gasket, Bolts, and Nuts: Type and material recommended by piping system manufacturer unless otherwise indicated.

2.3 TRANSITION FITTINGS-Plastic-PEX to Copper Pipe:

- A. Plastic-to-Metal Transition Fittings: Polyethylene one-piece fitting with one threaded brass or copper insert and one Schedule 80 solvent-cemented-joint end.

2.4 CASING PIPING SYSTEM

- A. Description: Factory-fabricated and -assembled, airtight and watertight, drainable, pressure-tested piping with conduit, inner pipe supports, and insulated carrier piping. Fabricate so insulation can be dried in place by forcing dry air through conduit.
- B. Carrier Pipe: PEX Flex Polyethylene pipe for underground hot water piping.
- C. Carrier Pipe Insulation:
 1. Polyurethane Foam Pipe Insulation: Unfaced, preformed, rigid cellular polyurethane material intended for use as thermal insulation.
 - a. Comply with ASTM C 591, Type I or Type IV, except thermal conductivity (k-value) shall not exceed 0.19 Btu x in./h x sq. ft. x deg F (0.027 W/m x K) at 75 deg F (24 deg C) after 180 days of aging.
 - b. Flame-spread index shall be 25 or less and smoke-developed index shall be 50 or less for thickness up to 1-1/2 inches (38 mm) as tested by ASTM E 84.
 - c. Fabricate shapes according to ASTM C 450 and ASTM C 585.
 - d. Insulation will cover the two (2) HW supply and return pipes, and one (1) tube with electric heat tracing wire, as a single prefabricated assembly. This assembly will be pulled, or jacked through the buried casing pipe.
- D. Minimum Clearance:
 1. Between Carrier Pipe Insulation and Casing: 1-1/2 inches
 2. Between Insulation of Multiple Carrier Pipes: minimum of 1-1/2 Inch
 3. Between Bottom of Carrier Pipe Insulation and Casing: 1 -1/2 inch.
- E. Conduit: PVC Schedule 80 Casing Pipe:

1. Cover or Finish: With two coats of fusion-bonded epoxy, minimum 20 mils (0.50 mm) thick, or ¼" thick PVC jacket.
 2. Piping Supports within Conduit: Provide internal supports of the prefabricated 6.5" OD carrier pipe assembly with a maximum spacing of 8 feet .
 3. Fittings: Factory-fabricated and -insulated elbows and tees. Elbows may be bent pipe equal to carrier pipe. Tees shall be factory fabricated and insulated, and shall be compatible with the carrier pipe. Each casing pipe is limited to one (1) 45 deg Elbow from tunnel to Toll Booth pit.
 4. Expansion Offsets and Loops: Size casing to contain piping expansion.
 5. Accessories include the following:
 - a. Water Shed: Terminal end protector for carrier pipes entering building through floor, 3 inches (75 mm) deep and 2 inches (50 mm) larger than casing; terminate casing 20 inches (500 mm) above the floor level.
 - b. Guides and Anchors: attached to carrier pipes and to casing, complete with vent and drainage openings inside casing.
 - c. End Seals: end seals attached to carrier pipes and to casing, complete with drain and vent openings on vertical centerline.
 - d. Gland Seals: Packed stuffing box and gland follower mounted on to end of casing, permitting axial movement of carrier piping, with drain and vent connections on vertical centerline.
 - e. Joint Kit: Half-shell, pourable or split insulation and shrink-wrap sleeve.
- F. Source Quality Control: Factory test 10" diameter casing pipe to 15 psig (105 kPa) for a minimum of two hours with no change in pressure. Factory test carrier pipes to 150 percent of the operating pressure of system. Furnish test certificates.

PART 3 - EXECUTION

3.1 EARTHWORK

- A. See Civil specification for excavating, trenching, and backfilling.

3.2 PIPING APPLICATION

- A. Hot-Water Heating Piping in Casing Pipes-Underground only:
1. NPS 2 (DN 50) and smaller shall be the following:
 - a. Schedule 80 carrier pipes Polyethylene plastic pipe and fittings and solvent-welded joints.
 - b. Provide adaptors for copper Type L for tunnel and toll booth interconnections with adaptors.
 2. Casing piping with polyurethane carrier-pipe insulation and within conduit. The hot water supply and return lines with heat tracing tube shall be wrapped as a unit with 6.5" OD jacket, as an assembly rolled from a reel. This will allow to

pull or jacking the carrier piping assembly up through the 10 inch UG casing pipe.

- a. Carrier Pipe Insulation Thickness: 2 inches (50 mm)
 - b. Conduit Insulation Thickness: None
3. Casing piping with polyurethane carrier-pipe insulation.
 - a. Piping Insulation Thickness: 2 inches (50 mm).

3.3 PIPING INSTALLATION

- A. Drawing plans, schematics, and diagrams indicate general location and arrangement of piping systems. Indicate piping locations and arrangements if such were used to size pipe and calculate friction loss, expansion, pump sizing, and other design considerations. Install piping as indicated unless deviations to layout are approved on Coordination Drawings.
- B. Remove standing water in the bottom of trench.
- C. Do not backfill piping trench until field quality-control testing has been completed and results approved.
- D. Install piping at uniform grade of 0.2 percent. Install drains, consisting of a tee fitting, NPS 3/4 (DN 20) ball valve, and short NPS 3/4 (DN 20) threaded nipple with cap, at low points and elsewhere as required for system drainage. Install manual air vents at high points.
- E. In casing pipes at low point end, install drain valves at low points and route to the tunnel.
- F. Casing piping with polyurethane carrier-pipe insulation and within conduit. The hot water supply and return lines with heat tracing tube shall be wrapped as a unit of assembly with 6.5" OD jacket, as an assembly rolled from a large reel starting from the tunnel. This will allow jacking the carrier piping assembly up through the 10 inch UG casing pipe to the toll booth pits, as noted on the drawings.
- G. Install components with pressure rating equal to or greater than system operating pressure.
- H. Install piping free of sags and bends.
- I. Install fittings for changes in direction and branch connections.
- J. See Section 15000 "Sleeves and Sleeve Seals for HVAC Piping" for sleeves and mechanical sleeve seals for the 10" diameter casing pipes through the toll booth pits, and the tunnel walls, as indicated on the drawings. Provide pipe sleeves 12 pipe for 10" casing pipe in the penetrations of the tunnel walls, and the Toll Booth's pit walls.

- K. Secure anchors with concrete thrust blocks. Concrete is specified in Section 03300 "Cast-in-Place Concrete."

3.4 JOINT CONSTRUCTION

- A. Join pipe and fittings according to the following requirements and Section 15000 for specifying piping systems.
- B. Ream ends of pipes and tubes and remove burrs. Bevel plain ends of steel pipe.
- C. Remove scale, slag, dirt, and debris from inside and outside of pipe and fittings before assembly.
- D. Soldered Joints: Apply ASTM B 813, water-flushable flux, unless otherwise indicated, to tube end. Construct joints according to ASTM B 828 or CDA's "Copper Tube Handbook," using lead-free solder alloy complying with ASTM B 32.
- E. Brazed Joints: Construct joints according to AWS's "Brazing Handbook," Ch. 35, "Pipe and Tubing," using copper-phosphorus brazing filler metal complying with AWS A5.8/A5.8M.
- F. Threaded Joints: Thread pipe with tapered pipe threads according to ASME B1.20.1. Cut threads full and clean using sharp dies. Ream threaded pipe ends to remove burrs and restore full ID. Join pipe fittings and valves as follows:
 - 1. Apply appropriate tape or thread compound to external pipe threads unless dry seal threading is specified.
 - 2. Damaged Threads: Do not use pipe or pipe fittings with threads that are corroded or damaged. Do not use pipe sections that have cracked or open welds.
- G. Welded Joints: Construct joints according to AWS D10.12M/D10.12.
- H. Flanged Joints: Select appropriate gasket material, size, type, and thickness for service application. Install gasket concentrically positioned. Use suitable lubricants on bolt threads.
- I. Plastic Piping Solvent-Cemented Joints: Clean and dry joining surfaces. Join pipe and fittings according to the following:
 - 1. Comply with ASTM F 402 for safe-handling practice of cleaners, primers, and solvent cements.
 - 2. Polyethylene Piping: Join according to ASTM D 2846/D 2846M Appendix.
 - 3. PVC Pressure Piping: Join ASTM D 1785 schedule number, PVC pipe and PVC socket fittings according to ASTM D 2672. Join other-than-schedule number PVC pipe and socket fittings according to ASTM D 2855.
- J. Casing Piping Joints: Assemble sections and finish joints with pourable or split insulation and exterior jacket sleeve, and apply shrink-wrap seals.

3.5 IDENTIFICATION

- A. Install continuous plastic underground warning tapes during back filling of trenches for underground hydronic casing pipes. Locate tapes 6 to 8 inches (150 to 200 mm) below finished grade, directly over piping. See Section 15000 for warning-tape materials and devices and their installation.

3.6 FIELD QUALITY CONTROL

- A. Perform the following tests and inspections:
 - 1. Prepare hydronic piping for testing according to ASME B31.9 and as follows:
 - a. Leave joints, including welds, uninsulated and exposed for examination during test.
 - b. Fill system with water. Where there is risk of freezing, air or a safe, compatible liquid may be used.
 - c. Use vents installed at high points to release trapped air while filling system.
 - 2. Test hydronic HW piping as follows:
 - a. Subject hydronic HW piping to hydrostatic test pressure that is not less than 1.5 times the design pressure at a minimum of 75 psig.
 - b. After hydrostatic test pressure has been applied for 10 minutes, examine joints for leakage. Remake leaking joints using new materials and repeat hydrostatic test until no leaks exist.
 - 3. Test Casing pipes as follows:
 - a. Seal vents and drains and subject conduit to 15 psig (105 kPa) for four hours with no loss of pressure. Repair leaks and retest as required.
- B. Prepare test and inspection reports.

END OF SECTION

SECTION 15250

INSULATION

PART 1 - GENERAL

1.1 RELATED DOCUMENTS

- A. The drawings and the specifications including the project manual are hereby made a part of the work of this section.

1.2 DESCRIPTION

- A. The work covered by this Section of the specifications includes the furnishing of labor, materials, equipment, transportation, permits, inspections and incidentals and the performing of operations required to insulate the heating, ventilating, air conditioning, and plumbing systems.

1.3 SUBMITTALS

- A. Substitutions: As approved by the Engineer. Attention is also directed to Section 15000-"Substitutions", relative to competition and the (ONLY) notation. Familiarity with this section shall be achieved before reading the PRODUCTS section of this specification.
- B. The items for which the submittals paragraph in Section 15000, Supplemental General Mechanical Requirements, apply are as follows:
 - 1. Piping insulation.
 - 2. Ductwork insulation
 - 3. Equipment insulation.
 - 4. Insulation application schedule.

1.4 DEFINITIONS

- A. Finished Spaces: Spaces other than furred spaces, pipe and duct shafts, unheated spaces immediately below roof, spaces above ceilings, unexcavated spaces, crawl spaces, and tunnels, unless specifically listed below as an unfinished space.
- B. Unfinished Spaces: Mechanical rooms.
- C. Unconditioned Spaces: Spaces exposed to near outside ambient temperatures, such as unheated attic spaces or non-air conditioned areas.
- D. Outside: Areas beyond the exterior side of walls or above the roof, unexcavated spaces, and crawl spaces.

- E. Concealed: Not visible in finished or unfinished spaces. For example, above ceilings, below floors, between double walls, furred-in areas, pipe and duct shafts, and similar spaces.
- F. Exposed: Visible from a finished or unfinished space.

1.5 MANUFACTURER'S STAMP OR LABEL

- A. Packages or standard containers of insulation, jackets, cements, adhesives, and coatings delivered to the project site for use must have the manufacturer's stamp or label attached giving name of manufacturer, brand, and description of material. Insulation shall be asbestos-free.

1.6 FLAME SPREAD AND SMOKE DEVELOPED RATINGS

- A. Materials shall have a flame-spread rating of not more than 25 and a smoke developed rating of not more than 50 when tested in accordance with NFPA 255, ASTM E84, or UL 723.
- B. Provide materials with flame resistant treatments not subject to deterioration due to aging, moisture, high humidity, oxygen, ozone, or heat.
- C. Materials Exempt From Fire-Resistant Rating: Nylon anchors for securing insulation to ducts or equipment.

PART 2 - PRODUCTS

2.1 PIPING INSULATION

- A. Fiberglass: Heavy density preformed fiberglass with thermal conductivity of 0.29 Btu-in/hr-ft²-°F at 150°F mean temperature. Insulation shall conform to ASTM C547 Class I and shall be suitable for 450°F service. Fitting insulation shall be of same material used for pipe.
 - 1. Insulation Jacket: All service (ASJ) type conforming to Fed. Spec. HH-B-100B Type I. Jacket permeability shall not exceed 0.02 perms (ASTM E96). Pipe fitting jacket shall be factory premolded, one-piece, PVC covers with pressure sensitive taped joints. Jackets in exposed locations shall have a white surface suitable for field painting. Provide vapor barrier as required by service.
 - 2. Aluminum Jackets: ASTM B 209M (ASTM B 209), Temper H14, minimum thickness of 27 gage (0.016 inch), with factory-applied polyethylene and kraft paper moisture barrier on inside surface. Provide smooth surface jackets for jacket outside diameters less than 8 inches. Provide corrugated surface jackets for jacket outside diameters 8 inches and larger. Provide 1/2" wide stainless steel bands. Provide factory prefabricated aluminum covers for insulation on fittings, valves, and flanges.

- C. Fittings, Flanges, and Valves: Provide insulation for fittings, flanges, and valves premolded, precut, or job fabricated of the same thickness and conductivity as used on adjacent piping.

2.3 EQUIPMENT AND DUCT INSULATION

- A. Fiberglass (Hot Equipment): Semi-rigid fiberglass board conforming to Fed. Spec. HH-I-558B, Form B, Type I. Thermal conductivity shall be 0.32 Btu-in/hr-ft²-°F at 150°F mean temperature (ASTM C177), insulation shall be suitable for 650°F service. Insulation jacket shall be "all service" type conforming to Fed. Spec. HH-I-100B Type I or II. Jacket permeability shall not exceed 0.02 perms (ASTM E96).
- B. Flexible Unicellular (Cold Equipment): Flexible unicellular with thermal conductivity of 0.27 Btu-in/hr-ft²-°F at 75°F mean temperature. Insulation shall conform to ASTM C534, Type II, sheet and shall be suitable for 200°F service. Permeability shall not exceed 0.10 perms (ASTM E96). Insulation adhesive shall conform to Mil. Spec. MIL-A-24179A, Type II, Class 1.

PART 3 - EXECUTION

3.1 SURFACE CONDITIONS

- A. Inspection:
 - 1. Prior to work of this Section, carefully inspect the installed work of other trades and verify that such work is complete to the point where this installation may properly commence.
 - 2. Verify that the insulation systems may be installed in accordance with pertinent codes and regulations and the reviewed Submittals.

3.2 GENERAL

- A. Insulate after system tests have been completed and surfaces to be insulated have been cleaned of dirt, rust, and scale and are dry.
- B. Install insulation with jackets drawn tight and cement down longitudinal and end laps. Do not use scrap pieces where a full length section will fit. Insulation shall be continuous through sleeves, wall and ceiling openings, except at fire dampers in duct systems and pipe penetrations through fire rated assemblies. Extend surface finishes to protect ends, and raw edges of insulation. Apply coatings and adhesives at the manufacturer's recommended coverage per gallon. Individually insulate piping and ductwork. Keep insulation dry during the application of the finish. Bevel and seal the edges of exposed insulation.
- C. Unless otherwise indicated, do not insulate the following:

1. Factory preinsulated flexible ductwork.
2. Factory pre-insulated ductwork, plenums, casings, mixing boxes, and filter boxes.
3. Chrome plated pipes and fire protection pipes.
4. Vibration isolating connections
5. Adjacent insulation
6. ASME stamps, nameplates, access plates
7. Ductwork exposed to view in a normally occupied space.
8. Hydronic specialties: Low water cutoff, relief valves, relief valve discharge piping, pressure reducing valves, and expansion tanks.
9. Unions and flanges at equipment required for frequent service.

3.3 PIPING INSULATION

- A. Pipe Insulation (Fiberglass): Place sections of insulation around the pipe and joints, tightly butt into place. Draw jacket laps tight and smooth. Secure jacket with fire resistant adhesive, or factory applied self sealing lap. Cover circumferential joints with butt strips, not less than 3-inches wide, of material identical to the jacket material. Overlap longitudinal laps of jacket material not less than 1-1/2 inches. Adhesive used to secure the butt strip shall be the same as used to secure the jacket laps.
- B. Flanges, Unions, Valves and Fittings Insulation (Fiberglass): Factory fabricated removable and reusable insulation covers. Place factory premolded, precut or field-fabricated segmented insulation of the same thickness and conductivity as the adjoining pipe insulation around the flange, union, valve, and fitting abutting the adjoining pipe insulation. Install factory premolded one-piece PVC fitting covers over the insulation and secure by stapling or with metal or plastic tacks made for securing PVC fitting covers and secure with PVC vapor barrier tape.
- C. Pipe Insulation (Flexible Unicellular): Bond cuts, butt joints, ends, and longitudinal joints with adhesive. Miter 90-degree turns and elbows, tees, and valve insulation. Insulate flanges, unions, valves, and fittings.
- D. Where penetrating roofs and exterior walls, insulate piping to a point flush with the underside of the deck or wall and seal with a vapor barrier coating.
- E. Hangers and Anchors: Pipe insulation shall be continuous through pipe hangers. Where pipe is supported by the insulation, provide MSS SP-58, Type 40 galvanized steel shields (16 gage maximum). For fiberglass insulation systems on pipe sizes 2 inches through 3", provide insulation inserts at points of hangers and supports. Insulation inserts shall be of molded glass fiber (minimum 12 pcf). Insulation inserts shall cover the bottom half of the pipe circumference, 180 degrees, and be not less than 4" long. Vapor-barrier facing of the insert shall be of the same material as the facing on the adjacent insulation. Seal inserts into the insulation. Insulation inserts for pipe sizes 4" and larger shall be welded pipe saddles. Install insulation in void area of saddle of same material used on adjacent insulation. For pipe sizes 2" and smaller, insulation inserts for flexible unicellular insulation systems shall

be wooden doweling set on end of length equal to insulation thickness. Seal dowel to insulation with adhesive.

- F. PVC or Metal Jackets: Provide over insulation. Machine cut jacket to smooth edge of circumferential joints. Overlap metal jacket not less than 2 inches at longitudinal and circumferential joints and secure with metal bands at not more than 9 inch centers. Overlap longitudinal joints down to shed water. Seal circumferential joints with a coating recommended by insulation manufacturer for weatherproofing. Solvent weld PVC jacket system to provide continuous watertight seal.

3.4 EQUIPMENT AND DUCT INSULATION

- A. General Procedures: Apply equipment insulation suitable for temperature and service to fit as closely as possible to equipment. Join sections of insulation with adhesive. Bevel insulation around nameplates, ASME Stamp, and access plates. For insulation on equipment that must be opened periodically for inspection, cleaning, or repair, construct insulation to be removable and replaceable without damage. Provide vapor barrier seal at joints and seams for "cold" equipment.
- B. Heating Equipment: Provide semi-rigid mineral fiberboard insulation. Seal longitudinal and lateral seams with FSK tape. Bond cuts, ends, and mitered sections with adhesive. Provide a vinyl-acrylic mastic coating on exposed fiberglass ends.
- C. Cold Equipment: Provide flexible unicellular sheet insulation, bond cuts, butt joints, longitudinal joints and ends with vapor barrier adhesive. Vapor seal exposed edges to equipment.

3.5 INSULATION APPLICATION SCHEDULE

<u>SERVICE</u>	<u>THICKNESS</u>	<u>MATERIAL/JACKET</u>
PIPING:		
Heating Hot Water Piping Copper 1" and smaller	1-1/2"	Fiberglass w/ASJ
Copper 1-1/4" to 2 " C Steel 2-1/2 and larger	1-1/2"	Fiberglass w/ASJ
Heating Hot Water underground Piping, 1-1/4" and smaller (in casing)	2"	Polyethylene (PEX)
Boiler water Piping Boiler Room	2"	Fiberglass w/ASJ

DUCTWORK:

Insulate the following ducts with installed thickness of fiberglass duct wrap or fiberglass board:

- a. Outside air ductwork 2” Fiberglass board, or w/ASJ
- b. Supply and Return 1-1/2" “ “
- c. AHU-1 Exhaust 1” Duct wrap for sound
attenuation in chase

3.8 FIELD INSPECTION

- A. Visually inspect to ensure that materials used conform to specifications. Inspect installations progressively for compliance with requirements.

END OF SECTION

SECTION 15400

PLUMBING

PART 1 - GENERAL

1.1 RELATED DOCUMENTS

- A. Work performed under this section of the specifications shall be subject to the General Conditions, Supplementary Conditions of the Contract and Division 1 General Requirements.

1.2 SUBMISSION OF OPERATION AND MAINTENANCE DATA

- A. Provide operation and maintenance (O&M) data/manuals which are specific to each section under Division 15 of this project. Each manual shall contain “as-built” drawings and the required data packages specified in its respective section. Each manual shall be complete and a concise depiction of the provided equipment or product. Hardcopies of each manual shall be contained in one or more, as appropriate, three ring notebooks with each volume identified. Provide a Table of Contents for every volume identifying the material with-in.
- B. Submit two hardcopies of each manual and three copies on CD-Rom’s, with system descriptions and/ or manufacturer’s O&M information specified, in the required data packages, for the components, assemblies, subassemblies, attachments, and accessories.

1.3 TYPE OF INFORMATION REQUIRED IN O&M DATA PACKAGES

- A. List personnel hazards and equipment or product safety precautions for all operating conditions.
- B. Provide a description for each operating procedure including control sequences.
- C. Provide a description of normal operating procedures. Include control diagrams with data to explain operation and control of systems equipment.
- D. Provide a description of emergency procedures to permit a short period of operation and to safely shut-down the system to prevent further damage to equipment. Include emergency shut-down procedures for fire, explosion or other contingencies.
- E. Provide instructions for services to be performed by maintenance personnel, such as lubrication, adjustment, inspection and reading of gages.

- F. List environmental conditions such as temperature and humidity limits for equipment.
- G. Provide a preventive maintenance plan and schedule. Include lubrication data, filter types and sizes for each piece of equipment.
- H. Provide instruction for correcting problems and making repairs. Provide troubleshooting and diagnostic techniques.
- I. Provide wiring diagrams, control diagrams, valve charts and list damper settings. Provide locations of each control device, valve and damper.
- J. Provide a list of special tools and testing equipment required to troubleshoot, diagnose and service each piece of equipment or product.
- K. Provide a spare parts list for maintenance and repair of each piece of equipment. List shall include name, address & telephone number of nearest dealer and replacement part number.
- L. Provide a supplies list for consumable products such as filters. The list shall include the name, address and telephone number of the nearest dealer where products made be purchased. Include part number and where applicable sizes, efficiencies, etc.
- M. Provide warranty information. Include the names, addresses, and telephone numbers of equipment manufacturers, dealers and service organizations (closest to the project) for equipment or product provided.
- N. Provide the name, address and telephone numbers of the installing subcontractor for each system installed. Provide the name, address and telephone number of the project's General Contractor.
- O. Provide a copy of submittals, shop drawings and "as-built" drawings for each system installed. Provide dimensioned locations for concealed items and piping below slab.

1.4 LAWS AND ORDINANCES

- A. All plumbing work shall be installed and tested in accordance with State Plumbing Code as revised to date and with all other State Codes governing this work that may apply.
- B. Gas fitting shall be done in compliance with NFPA, State Gas Code Requirements and those of the company supplying the gas.
- C. Plumbing Contractor shall file all required notices and plans with the proper authorities and shall secure and pay for all necessary permits inspections and costs incidental to his work beyond the regular Building Permit, no work shall commence prior to this.

- D. Selection of all plumbing materials and equipment shall conform to the latest edition of the prevailing State Codes.
- E. Where the requirements of this specification are more stringent than the prevailing State Codes, the requirements of this specification shall govern.
- F. All work shall conform to all applicable State and the latest editions of applicable Factory Mutual Data Sheets.
- G. All Plumbing materials, fixtures, components, accessories, and / or equipment provided for construction of plumbing systems specified herein shall be listed and approved for construction by the State Plumbing Board.

1.5 GUARANTEES

- A. Furnish to Owner at completion of this work, a written guarantee stating that all equipment, materials, and work performed are in full accordance with drawings and specifications. Guarantee shall also state that this work and all subsequent change orders are fully guaranteed for 1 year from the date of final acceptance, and any equipment, materials, or workmanship which may prove defective within that time will be replaced at no cost to Owner.

1.6 DRAWINGS

- A. Plumbing Contractor shall refer to the Plumbing Construction Drawings and Architectural, Structural, Mechanical, and Electrical plans for a full comprehension of the extent of and the detail of the work to be performed.
- B. Work installed by the Plumbing Contractor that interferes with or modifies the architectural design as shown on the contract drawing, shall be changed as directed by the Engineer and all costs incidental to such changes shall be paid by the Plumbing Contractor.
- C. In any and all cases of discrepancy in figures, plans or specifications, the matter shall be immediately submitted to the Plumbing Engineer for a decision.
- D. The drawings are diagrammatic and do not allow for all offsets, fittings, valves, etc., which may be required to complete the work. This Contractor shall study the drawings denoting structural and finish design of the building to allow for the proper installation of all fittings, valves, fixtures, trim, traps, carriers, etc., necessary to fully complete the plumbing work to give a fully operational, trouble-free system.
- E. Provide and install, as approved by the Engineer, all subparts for all main equipment, such as: tempering valves, check valves, backflow preventers, vacuum breakers, shock absorbers, trap primers, etc. A careful study of all plans shall be made in order to determine all of the plumbing items required to make a complete system. Not all items are shown or called for herein, but this will not relieve this

Contractor from supplying a complete system approved by the proper authorities at no additional cost to the Owner.

- F. Where valves cannot be placed in an accessible area, approved covers and frames shall be provided and built into the work. These are not indicated on the drawing but are required.
- G. Provide all plant facilities, labor, materials, tools, equipment, appliances, transportation, supervision and related work necessary to complete, in place, the work specified in this section, and as shown on the drawings.
- H. Drawings indicate the extent and general arrangement of plumbing systems. If any departures from drawings are deemed necessary by Plumbing Contractor, details of such departures and the reasons therefore shall be submitted to Owner and Architect for approval. No such departures shall be made without prior written approval of Owner and Architect. Equipment and piping arrangements shall provide adequate and acceptable clearances for entry, servicing and maintenance.
- I. Plumbing Contractor shall be responsible for coordinating his work with the General Contractor and other Trades, and agreeing to locations of openings for his work.
- J. Before placing of concrete slabs on grade, Plumbing Contractor shall check with electrical and mechanical subcontractors to confirm that all under slab floor appurtenances, inserts, pipes, ducts, conduits, drains, steel frames, outlets, etc., have been placed, tested and in their proper locations. Floor areas within Tenant's space shall not be poured until the Architect's or Owner's representative approval is given for each area.
 - 1. Mechanical and electrical subcontractors are responsible for any missing items. Any routing, saw cutting, etc., of concrete floors required for placement after slabs are poured shall be by the respective subcontractor and same is to be done at its expense.
 - 2. All conduit, duct, pipe, etc., shall be placed below slab.
- K. Plumbing Contractor shall guaranty all work, materials and equipment for one year after final acceptance

1.7 SHOP DRAWINGS AND EQUIPMENT SUBMITTALS

- A. Plumbing Contractor shall maintain at the site an up-to-date marked up set of "As-Built" drawings to show as-built conditions, which shall be submitted to Owner at completion of work.
- B. Plumbing Contractor shall prior to placing orders for any materials and / or fabrications, submit equipment submittals for review and approval.
- C. All Plumbing equipment submittal sets shall be bound listing corresponding mark and pertinent data, highlighted and checked for the following fixtures and

equipment included under this section denoting name of manufacturer, model #, composition, finish, grade, size, capacity, etc:

1. Plumbing Fixtures, Carriers and Trim.
2. Floor Drains and Roof Drains.
3. Floor and Wall Cleanouts.
4. Wall Hydrants and Hose Bibs.
5. Shock Absorbers and Trap Primer Valves.
6. Backflow Preventers, Vacuum Breakers and Air Gap Fittings.
7. Water Heaters, Tempering Valves, Thermometers, Pressure Gages, T&P Valves, Vacuum Relief Valves.
8. All Ball Valves, Gas Valves, Check Valves, etc. specified herein.
9. All pipe and fittings specified herein.
10. Water meters.
11. All Hangers, Rods, Clamps and pipe insulation shields specified herein.
12. Seismic Hangers and Restraints.
13. All Pipe Insulation and PVC Covers.
14. Gas Pressure Reducing Valves.
15. Escutcheons.
16. Pipe Labels.
17. Propane Tanks
18. Pumps
19. Written letter from the Plumbing Contractor stating all piping systems above and below ground specified herein have been tested, flushed and approved by the State Plumbing Inspector.
20. Written letter from the Plumbing Contractor stating all gas piping systems specified herein have been tested, purged and approved by the State Plumbing and/or Gas Inspector.
21. Test certificates, registration forms, diagrams, plans, details, permits, etc. for all backflow devices, as specified herein with a written cover letter from a certified backflow protection device tester stating that all testable backflow devices have been tested.
22. Written letter, stamped and signed by a Registered Structural Engineer, confirming that the pipe hanger system meets the state seismic code requirements.
23. Shop drawings and calculations detailing seismic hanger restraints.
24. A written cover letter, attached to the insulation materials submittals, from the Insulation Contractor stating an outline for all insulating materials furnished and installed for all piping systems specified herein.
25. Each submittal set shall include a cover sheet with project name and location and table of contents.
26. All pipe hangers and equipment supports to be constructed and installed in accordance with zone requirements as outlined in the State Building Code.
27. Plumbing Contractor shall submit one (1) copy of the shop drawings and calculations detailing seismic hanger restraints to State Building Authority, engineer, and Owner, along with a letter of compliance stamped and signed by a registered Structural Engineer confirming that the piping hangers meet the State Seismic Code Requirements.
28. Layout and detail of pipe anchors, pipe supports, expansion loops, etc., to be submitted for approval via shop drawings before start of construction.

1.8 EXCAVATION AND BACKFILL

- A. Work under this section shall commence only after proper bedding material has been provided, graded and properly compacted. Excavation shall be kept open until system has been inspected, tested and approved.
- B. Plumbing Contractor shall observe all excavation, backfilling and compaction of all underground piping associated with work under this section.
- C. All water piping running below slab shall be insulated (as specified herein) and buried to a minimum depth of 6" below finished floor.

1.9 WORKMANSHIP, MATERIALS, DELIVERY, HANDLING AND STORAGE

- A. Workmanship shall be of best quality and none but competent workmen skilled in their trades shall be employed. Plumbing Contractor shall furnish services of an experienced superintendent, who will be constantly on site and in charge of erection of work, until completed and accepted.
- B. Unless otherwise hereinafter specified, all materials and equipment under this Section of the Specifications shall be new, of best grade and as listed in printed catalogs of the manufacturer. Each article of its kind shall be standard product of a single manufacturer.
- C. Whenever the words "or equal", "equivalent equipment", "acceptable" or other words of similar intent or meaning are used, implying that judgment is to be exercised, it is understood that it is the judgment of Architect that is referred to.
- D. All fixtures and materials must be new, unused, free from defects and/or imperfections.
- E. All work shall be done by skilled workman in accordance with the best practices of the trade.
- F. All respective materials and equipment specified herein shall be of the same manufacturer, identified by makers name, mark, rating and approved standards where applicable.
- G. Work shall be executed in strict conformity with the latest edition of the prevailing State Plumbing and Building Codes that may apply. In case of conflict between the Contract Documents and a governing code or ordinance, the more stringent standard shall apply. If any work is performed and subsequent changes are necessary, these changes shall be made at the Plumbing Contractor's expense.
- H. All plumbing materials and equipment shall be selected and designed so as to conform to applicable State Codes. Water heaters, storage tanks, aerators, flow control fittings, insulation, etc., shall be selected with efficiencies and design conditions to meet applicable energy codes.

- I. Unless otherwise specified herein, all materials and workmanship shall conform to the latest edition of the following standards and specifications: ADA, CSA, AWS, ANSI, ASHRAE, ASME, ASTM, CISPI, CS, MSS, NEC, NFPA, PDI, PFI, UL, FM and USC.
- J. Plumbing Contractor shall observe all concrete pours in areas associated with work performed under this section.
- K. All plumbing fixtures, trims, accessories, specialties, components, etc., specified herein shall be of the same respective manufacturers unless noted otherwise herein.

1.10 GIVING INFORMATION

- A. Plumbing Contractor shall keep himself fully informed as to shape, size, and position of all openings and foundations required for his apparatus and shall give full information to General Contractor sufficiently in advance of the work, so that all such openings and foundation may be built in advance. He shall also furnish all sleeves and supports herein specified or required, so General Contractor may build same in place.
- B. Plan all work so that it proceeds with a minimum of interference with other trades. Inform General Contractor of all openings required in building construction including roof openings for installation of his work. Provisions shall be made for all special frames, openings, and pipe sleeves as required. Cutting, patching and core drilling made necessary by his failure to properly direct and supervise such work at the correct time shall be done and paid for by Plumbing Contractor.

1.11 CLEANING AND ADJUSTING

- A. At the completion of work, all fixtures, equipment, specialties, components, and exposed trim shall be cleaned, and where required, polished ready for use. Faucet washers which have been damaged during construction shall be replaced. All drains, sediment buckets and traps shall be thoroughly cleaned.
- B. At the completion of work, all floor drain, floor cleanout grates and frames shall be etched with muriatic acid and buffed with a fine wire brush until bright.
- C. At the completion of work, all valves and automatic control devices shall be adjusted for proper and quiet operation of all plumbing systems specified herein under this section. Hot water system shall be adjusted for proper operation.

1.12 PIPE IDENTIFICATION

- A. Provide color-coded pipe identification markers on piping installed under this section. Pipe markers shall be snap-on laminated plastic protected by clear acrylic

coating. Pipe markers shall be applied after architectural painting where such is required.

- B. Provide arrow marker with each pipe content marker to indicate direction of flow. If flow can be in either direction, use double-headed arrow marker.
- C. All piping shall be labeled at points of entrance and exit from all Sprinkler and Mechanical Rooms, adjacent to each valve, on each riser, at each tee fitting, at points of entrance and exit from building, at least once in each room, at each fixture and/or each fixture group within a room, and at intervals no longer than 20 feet above finished ceiling or below, where exposed.
- D. In general, 2" high legend shall be used for pipe lines 4" diameter and larger and 3/4" high legend shall be used for pipe lines 3" diameter and smaller.
- E. Markers shall be "Setmark" by Seton Name Plate Corp., or approved equal.
- F. Color banding shall meet ANSI A13.1-1975 and OSHA.
- G. Color coding shall be used with names in black letters on background as indicated herein:

<u>Service</u>	<u>Legend</u>	<u>Background Color</u>
Cold Water	Cold Water	Green
Hot Water	Hot Water	Yellow
Gas	Gas	Yellow
Vent	Vent	Yellow
Storm	Storm Sewer	Green

1.13 TAGS

- A. Upon completion of work, attach stamped, brass, black-filled tags to all valves. Tags shall be 19-gage, 1-1/2" diameter with numerals at least 1/2" high, and attached by "S" hooks or chains. A framed "Valve Chart" shall accompany such work and be mounted in Mechanical Room.

1.14 RECORD DRAWINGS

- A. Prepare record documents, indicate the following installed conditions:
 1. Mains and branches of piping systems, with valves and control devices located and numbered, concealed unions located, and with items requiring maintenance located (i.e., traps, strainers, expansion compensators, tanks, etc.). Valve location diagrams, complete with valve tag chart. Indicate actual inverts and horizontal locations of underground piping.
 2. Equipment locations (exposed and concealed), dimensioned from prominent building lines.
 3. Approved substitutions, contract modifications, and actual equipment and materials installed.

1.15 WORK SEQUENCE

- A. The Work shall be performed in phases to accommodate the Owner's occupancy requirements and the General Contractor's phasing plan during the construction period.

1.16 COORDINATION

- A. The Contractor shall acquaint himself with space requirements of other trades and call to the Architect/Engineer's attention any conflicts noted prior to performing any work. If work is started without notice to the Architect/Engineer, Contractor assumes responsibility for any work that has to be done over.
- B. Contractor shall have materials on the job and erected in conformance with building work schedule and in full coordination with other trades. Coordination with the Electrical Contractor to assure proper power supply to each component is the responsibility of the Plumbing Contractor.
- C. Coordinate installation of plumbing equipment and materials with all other building components.
- D. Verify all dimensions by field measurements.
- E. Arrange for chases, slots, and openings in other building components to allow for plumbing installations.
- F. Coordinate the cutting and patching of existing building components to accommodate the installation of plumbing equipment and materials.
- G. Where mounting heights are not detailed or dimensioned, install plumbing services and overhead equipment to provide the maximum headroom possible consistent with being serviceable.
- H. Install plumbing equipment to facilitate maintenance and repair or replacement of equipment components. As much as practical, connect equipment for ease of disconnecting, with minimum of interference with other installations.
- I. Coordinate the installation of plumbing materials and equipment above ceiling with suspension system, light fixtures, and other installations.
- J. Coordinate connections of plumbing systems with exterior underground and overhead utilities and services. Comply with requirements of governing regulations, franchised service companies, and controlling agencies. Provide required connection for each service.

1.17 PAINTING OF EQUIPMENT

- A. Provide manufacturer's standard factory painting systems for all new equipment.

- B. Clean, pre-treat, prime and shop paint metal, except aluminum. Paint items and devices not factory painted but exposed to the elements or in view in finished areas. Do not paint concealed surfaces or surfaces covered with insulation.

1.18 CUTTING AND PATCHING

- A. Do not endanger or damage installed Work through procedures and processes of cutting and patching.
- B. Arrange for repairs required to restore other Work, because of damage caused as a result of plumbing installations.
- C. No additional compensation will be authorized for cutting and patching Work that is necessitated by ill-timed, defective, or non-conforming installations.
- D. Cut, remove and legally dispose of any indicated mechanical equipment, components, and materials as required.
- E. Protect the structure, furnishings, finishes, and adjacent materials not indicated or scheduled to be removed.
- F. Provide and maintain any required temporary partitions or dust barriers adequate to prevent the spread of dust and dirt to adjacent areas.
- G. Locate, identify, and protect mechanical and electrical services passing through remodeling or demolition area and serving other areas required to be maintained operational.

PART 2 - PRODUCTS

2.1 GENERAL

- A. Where multiple items of equipment or materials are required they shall be the product of a single manufacturer.
- B. Before ordering any equipment, the size of all equipment shall be checked to easily fit spaces allotted on the drawings.
- C. Inserts, pipe sleeves, supports and anchorage of equipment shall be provided as specified herein. Where such items are to be set or embedded in concrete, masonry or similar work, the items shall be furnished and layout made at the proper time for the setting or embedment thereof so as to cause no delay in the work.
- D. The drawings are diagrammatic and may not detail all appurtenances required for the proper operation of all equipment. Provide such items for a complete and operable system.

2.2 PIPE

- A. Piping Systems – Common Requirements:
1. All domestic water made of copper pipe, all propane piping made of schedule 40 black steel pipe, all waste, vent, sewer and storm lines made of schedule 40 cast iron soil pipe and fittings shall conform to the requirements of ASTM for all pipe and fittings.
 2. General Locations and Arrangements: Drawings (plans, schematics, and diagrams) indicate general location and arrangement of piping systems. Install piping as indicated, except where deviations to layout are approved on coordination drawings.
 3. Install piping at indicated slope.
 4. Install components having pressure rating equal to or greater than system operating pressure.
 5. Install piping in concealed interior and exterior locations, except in equipment rooms and service areas.
 6. Install piping free of sags and bends.
 7. Install exposed interior and exterior piping at right angles or parallel to building walls. Diagonal runs are prohibited, except where indicated.
 8. Install piping tight to slabs, beams, joists, columns, walls, and other building elements. Allow sufficient space above removable ceiling panels to allow for ceiling panel removal.
 9. Install piping to allow application of insulation plus 1-inch (25 mm) clearance around insulation.
 10. Locate groups of pipes parallel to each other, spaced to permit valve servicing.
 11. Install fittings for changes in direction and branch connections.
 12. Install couplings according to manufacturer's printed instructions.
- B. System Performance Requirements: Provide components and installation capable of producing piping systems with the following minimum working pressure ratings, except where indicated otherwise:
1. Water Distribution Systems, Below Ground: 150 psig.
 2. Water Distribution Systems, Above Ground: 125 psig.
 3. Soil, Waste, and Vent Systems: 10-foot head of water.
- C. Pipe and fittings shall conform to the latest ANSI, ASTM, ASME and Commercial Standards CS.
- D. Each length of pipe, each pipe fitting, trap, material and device used in the plumbing system shall have cast stamped or indelibly marked on it, the maker's name or mark, weight and quality of the product when such marking is required by the approved standard that applies.
- E. Materials shall be new, unused, best of their respective kinds, and free from defects, and must be U.S. manufactured. Reference to specifications of recognized authorities, to establish bases of quality: latest edition in force at date of bidding. All materials shall be selected in accordance with State Plumbing Code and regulations and/or other applicable rules and regulations.

- F. Soil Piping - *Materials*:
1. Sanitary and Vent (Cast Iron):
 - a. Pipe (Above Slab): Service weight no hub cast iron soil pipe.
 - b. Pipe (Below Slab): Service weight bell and spigot cast iron pipe.
 - c. Fittings (Above Slab): Neoprene gasket with 304 stainless steel shield and clamp, minimum 3-inches wide
 - d. Fittings (Below Slab): Oil free oakum and lead
- G. Soil Piping - *Joints*: Cast iron pipe shall be joined by the following methods and materials in accordance with State Plumbing Codes and regulations.
- H. Storm Piping - *Materials*:
1. Storm Drainage (Plastic Pipe):
 - a. Pipe (Above Slab): Service weight no hub cast iron soil pipe.
 - b. Pipe (Below Slab): Service weight bell and spigot cast iron pipe.
 - c. Fittings (Above Slab): Neoprene gasket with 304 stainless steel shield and clamp, minimum 3-inches wide
 - d. Fittings (Below Slab): Oil free oakum and lead
- I. Water Piping (Copper Tube) – *Materials* (All materials shall be selected in accordance with State Plumbing Code and regulations):
1. Pipe:
 - a. (Above Slab): Type “L” copper tubing, hard drawn, hard temper.
 - b. (Below Slab): Type “K” copper tubing, annealed.
 2. Fittings (Above and Below Slab): Wrought copper and cast brass fittings, sweat and threaded.
 3. Joints:
 - a. (Above Slab): Sweat joint, lead-free solder and flux.
 - b. (Below Slab): Brazed joint, silver solder (locally approved grade).
 4. Ball Valves: Bronze body, bronze chrome-plated ball, reinforced Teflon seats and seals, steel lever handle with vinyl grip and hole penetration for valve tag, 400 psi working pressure.
 - a. Soldered Ends: Apollo 70-200 Series or approved equal.
 - b. Threaded Ends: Apollo 70-100 Series or approved equal.
- J. Propane Gas Piping (Steel Pipe) – *Materials* (All materials shall be selected in accordance with State Plumbing Code and regulations):
1. Pipe:
 - a. (Above Slab): Black steel, Schedule 40, standard weight (all pipe sizes).
 - b. (Below Slab): Wrapped black steel, Schedule 40, standard weight, CSA approved (all pipe sizes).
 2. Fittings:
 - a. (Above Slab): (2" and smaller) Black malleable iron fittings,

- screwed, 150 psi.
 - b. (Above Slab): (2" and larger) Welded or flanged.
 - 3. Joints - (Above Slab): (2" and smaller) screwed with state approved pipe joint material:
 - a. (Above Slab): (2" and larger) Welded or flanged.
 - b. (Below Slab): All sizes welded.
 - c. Verify Max size allowable for screwed joints with the authorities having jurisdiction.
 - 4. Valves:
 - a. Plug Valves:
 - 1) (2" and larger): All iron, full port, lubricated plug, flanged ends, 125 psi working pressure.
 - 2) (2" and smaller): All iron, full port, lubricated plug, screwed ends, 125 psi working pressure.
 - 3) (2" and smaller): All bronze, flat tee head, top check, screwed ends, 125 psi working pressure.
 - b. Ball Valves - (2" and smaller): Bronze body, full port bronze chrome-plated ball, reinforced teflon seats and seals, screwed ends, stainless steel tee handle and lever nut, 600 psi working pressure.
 - 1) Threaded Ends: Apollo 70-100-32 Series, Jomar Model T-100, or approved equal.
 - c. Gate Valves – Bronze body, non-rising-stem gate valves similar to Apollo, Nibco, Watts or approved equal.
- K. Condensate Piping (Copper Tube) – *Materials* (All materials shall be selected in accordance with State Plumbing Code and regulations):
 - 1. Pipe (Above Slab): Type “L” copper tubing, hard drawn, hard temper.
 - 2. Fittings (Above): Wrought copper and cast brass fittings, sweat and threaded.
 - 3. Joints (Above Slab): Sweat joint, lead-free solder and flux.

2.3 PIPE AND TUBE SPECIFICATIONS

- A. Hard Copper Tube: ASTM B88, Types K, L, and M, water tube, drawn temper.
- B. Soft Copper Tube: ASTM B88, Types K and L, water tube, annealed temper.
- C. Copper Drainage Tube: ASTM 8306, Type DWV, drawn temper.
- D. Steel Pipe: ASTM A53, Type S, Grade A, Schedule 40, seamless, galvanized, plain ends.
 - 1. Steel Pipe Nipples: ASTM A733, made of ASTM A53 or ASTM A106, Schedule 40, seamless, galvanized, carbon-steel pipe.
- E. Ductile-Iron Pipe: AWWA C151, Classes 50 and 51, mechanical joint and push-on joint, with AWWA C104 cement-mortar lining.

- F. Flanged Ductile-Iron Pipe: AWW A C115, ductile-iron barrel, Class 150 or 300 iron-alloy threaded flanges, with AWWA C104 cement-mortar lining.
- G. Cast Iron Pipe: ASTM A 74 service class, gaskets ASTM C 564 rubber, caulking materials, ASTM B29, pure lead and oakum or hemp fiber.

2.4 PIPE FITTING AND TUBE FITTING SPECIFICATIONS

- A. Wrought-Copper, Solder-Joint Pressure Fittings: ASME 816.22.
- B. Cast-Copper-Alloy, Solder-Joint Pressure Fittings: ASME 816.18.
- C. Wrought-Copper and Bronze, Grooved-End Fittings: ASTM B75 Tube and ASTM B584 Bronze Castings.
- D. Wrought-Copper, Solder-Joint, DWV Drainage Fittings: ASME 816.29.
- E. Cast-Copper-Alloy, Solder-Joint, DWV Drainage Fittings: ASME 816.23.
- F. Copper Tube, Grooved-End Mechanical Fittings: ASTM 875, copper tube and ASTM 8584 bronze castings.
- G. Bronze Flanges: ASME 816.24, Classes 150 and 300.
- H. Copper Unions: ASME 816.18, cast-copper-alloy body, hexagonal stock, with ball-and-socket joint, metal-to-metal seating surfaces, and solder-joint, threaded, or solder-joint and threaded ends.
 - 1. Threaded Ends: Threads conforming to ASME 81.20.1.
- I. Mechanically Formed Outlets: Manufacturer's standard written procedure for forming tee-branch outlet from pipe and tube.
- J. Malleable-Iron Unions: ASME B16.39, Classes 150 and 300, hexagonal stock, with ball-and-socket joint, metal-to-metal bronze seating surfaces; and female threaded ends having threads conforming to ASME B1.20.1.
- K. Galvanized, Cast-Iron Threaded Fittings: ASME 816.4, Classes 125 and 250, standard pattern, with threads conforming to ASME 81.20.1.
- L. Galvanized, Cast-Iron Threaded Drainage Fittings: ASME 816.12, recessed drainage pattern, with threads conforming to ASME 81.20.1.
- M. Steel Pipe, Grooved-End Fittings: ASTM A47 malleable-iron, ASTM A106 steel, or ASTM A536 ductile-iron, galvanized, grooved-end fittings designed to accept couplings for grooved or shouldered joints.
- N. Ductile-Iron Pipe, Grooved-End Fittings: ASTM A47 malleable-iron or ASTM A536 ductile-iron, AWW A-pipe-size, grooved-end fittings having cement lining

or FDA-approved interior coating, designed to accept AWWA C606 couplings, for AWWA grooved joints.

- O. Ductile-Iron and Gray-Iron Flanged Fittings: AWW A C11 0, 2SO-psig minimum pressure rating, with AWWA C104 cement-mortar lining.

2.5 JOINTS AND CONNECTIONS

- A. Ductile-Iron Pipe and Ductile-Iron or Cast-Iron Fittings: The following materials apply:
 - 1. Push-On Joints: AWWA C111 rubber gaskets and lubricant.
 - 2. Mechanical Joints: AWWA C111 ductile-iron or gray-iron glands, high-strength steel bolts and nuts, and rubber gaskets.
 - 3. Flanged Joints: AWW A C115 ductile-iron or gray-iron pipe flanges, rubber gaskets, and high-strength steel bolts and nuts.
- B. Couplings for Grooved-End Copper Tube and Grooved-End Copper Fittings: ASTM A536 ductile-iron or ASTM A47 malleable-iron housing having copper-colored enamel finish, with synthetic-rubber gasket having central-cavity, pressure-responsive design and suitable for hot water, with ASTM A183 carbon-steel bolts and nuts.
- C. Joints and connections shall be permanent and shall be gas and water tight.
- D. Jointing shall be types specified for service indicated.
- E. Joints and connections shall meet requirements of manufacturers best recommended practice.
- F. All transitions between different piping materials shall be made using approved adapters.
- G. Adapters for transitions between two types of piping materials shall be manufactured for purpose intended.
- H. Plumbing Contractor shall utilize only lead-free solder and flux when sweating copper water piping specified herein.
- I. Heat bending copper piping shall not be permitted in lieu of sweat and/or threaded pipe fittings.
- J. Jointing Compounds: Provide pipe dope, Teflon tape, wax rings, neoprene gaskets and other jointing compounds as required by best standard practice and only on service as recommended by manufacturer. Work shall conform to manufacturer's recommendations with regard to use of putties, jointing compounds or both in installing plumbing fixtures and trim.
- K. Grooved Pipe and Grooved-Pipe Fitting Joints: Assemble joints with coupling, gasket, lubricant, and bolts according to coupling and fitting manufacturer's

written instructions.

- L. Grooved Copper Tube and Grooved- Tube Fitting Joints: Assemble joints with coupling, gasket, lubricant, and bolts according to coupling and fitting manufacturer's written instructions.
- M. Mechanically Formed Outlet Joints: Make joints according to forming equipment manufacturer's written instructions. Use tool designed for piping material being joined, drill pilot hole, and form collar for branch connection. Copper Tube: Dimple tube to form seating stop and braze branch tube into formed collar outlet.
- N. Handling of Solvent Cements, Primers, and Cleaners: Comply with procedures in ASTM F402 for safe handling during joining of plastic pipe and fittings with solvent cements.

2.6 VALVES AND COCKS

- A. A gas union and coupling shall be installed in each gas line for each gas-fired unit and/or equipment specified herein. Valve shall be the full size of the branch line indicated on the drawing - not the final unit or equipment connection size.
- B. All valves of similar service shall be of same manufacture and have Manufacturer's name or trade mark and working pressure stamped or cast on the body.
- C. Provide a stop valve on each water supply directly under and/or in same room as each plumbing fixture, specialty and/or accessory unless specified otherwise herein.
- D. All hot and cold water branch supplies shall have ball valves installed on each branch line off main where possible ball valves shall be located 1'-0" above finish ceiling directly above fixture or fixture group, specialties, components and/or equipment unless specified otherwise herein.
- E. Install piping in a neat manner with lines strait and parallel or at right angles to walls or column lines and with risers plumb, run piping so as to avoid passing through ductwork or directly under electric light outlets, and/or interfering with other lines. All work shall be accomplished using the best methods and procedures or recognized pipe fabrication in a good and workmanlike manner in accordance with the State Plumbing Code and regulations.

2.7 PLUMBING SPECIALTIES

- A. Pressure Reducing Valves: (*Where Required*)
 - 1. (PRV-1) Pressure Type, Inlet/Outlet Size Reducing Valve (Domestic Water Service): Watts #U5B 2", bronze body, renewable steel seat, integral stainless steel strainer, adjustable pressure range set at 50 psi with maximum temperature 200°F.

- B. Expansion Tank:
1. Designed and constructed per ASME code section VIII, Division 1. In-line model with steel shell and heavy duty diaphragm and polypropylene liner and a factory pre-charge of 55 psig and a maximum working pressure of 150 psig.
- C. Pressure Gages - (P) Pressure Gage (General):
1. Terrice Model #600C, direct mounting, bourdon tube type, industrial pressure gage with bronze movement, cast aluminum case with black finish, stainless steel friction ring, glass window, 4-1/2" dial face, white scale background, black embossed figures and markings, black pointer, pressure range - 0 to 160 psig, and an accuracy to 1% of full scale over mid half of range and 2% of full scale over first and last quarter of range.
 - a. Furnish and install at cold water entrance, bourdon spring type pressure gages.
 - b. Furnish and install at hot water heaters (see Water Heaters).
 - c. Furnish and install at pressure reducing valves.
- D. Water Hammer Arrestors:
1. Josam Series 7500, Zurn Z-1700, J.R. Smith Series 500 or approved equal.
 2. Fixtures and equipment supplied in battery may be provided with one water hammer arrestor properly sized for connected load.
 3. Provide proper access to water hammer arrestors.
 4. Size and install in accordance with Plumbing and Drainage Institute "Standard PDI WH201".
- E. Unions, Flanges and Dielectric Couplings:
1. Plumbing Contractor shall provide union connections to fixtures and equipment such as water heaters, circulating pumps, HVAC equipment, water meters, backflow preventers, etc., as specified herein. Union connections shall include, but shall not be limited to, unions, flanges, compression fittings, grooved couplings, compression couplings and flared fittings. Union connections on domestic water piping shall be bronze with minimum cold working pressure of 200 psi. Union connections on iron and steel shall be ferrous with working pressure matching service pressure.
 2. Flanges: Provide flanges in accordance with ANSI standards for construction and working pressure. Flange material shall be ferrous for ferrous piping systems and bronze for non-ferrous systems.
 3. Dielectric Couplings: Wherever domestic water piping system comes in contact with ferrous pipe, fittings, valves and other equipment which makes up domestic water system, connections shall be made with flanges. Contact between ferrous stud bolts and non-ferrous bronze flanges shall be electrically insulated with non-metallic washers.

2.8 SLEEVES

- A. Plumbing contractor shall furnish and install separate sleeves for all steel, wrought iron, brass and copper pipe passing through walls, floors, partitions,

ceilings, and foundations except piping passing through slab on grade construction of which only water piping shall be sleeved, unless denoted on Plumbing Construction Drawings or specified otherwise herein.

- B. Sleeves shall be standard weight, black I.P.S. steel pipe except for copper piping passing through slab on grade construction of which schedule 40 PVC pipe sleeves shall be provided in lieu thereof. Size sleeves two sizes larger than the nominal diameter of the pipe or insulated pipe.
- C. Sleeves for concealed pipes in chases shall project 2" above finished floor. Sleeves for pipes exposed to view shall project 1" above finished floor. Sleeves passing through walls shall terminate flush with wall surface, sleeves in equipment spaces shall project 2" above finished floor. Sleeves passing through basement or depressed floors shall project 2" above finished floor.
- D. Pack and seal space between the pipe and sleeve or insulation and sleeve with an approved, non-shrinking, non-combustible packing material and/or approved firestop sealant maintaining an air tight seal.
- E. Sleeves through floors and walls below grade shall be Schedule 40 black steel pipe with 150-pound black steel slip-on welding flanges, welded at center of sleeve, painted with one coat of bitumastic paint inside and outside. Space between sleeve and pipe shall be packed with oakum to within two inches of each wall face. Remaining space shall be packed and made watertight with waterproof mastic.
- F. Every precaution shall be taken to place sleeves for all pipes before concrete is poured and masonry is finished. Any subsequent cutting and repair of construction due to the neglect or oversight by the Plumbing Contractor in carrying out these instructions will be done at his own expense.
- G. Plumbing Contractor shall coordinate the location of all sleeves with the General Contractor.
- H. Where required by State code, Plumbing Contractor shall furnish and install an approved fire stop material in the form of an approved fire rated assembly as manufactured and recommended by Specified Technologies, Inc. "Spec Seal Fire Stop Sealant" products for all piping penetrations through walls, floors and partitions, etc., specified herein.
- I. Pipe sleeves through floors and walls below grade serving the building domestic water service shall be sealed watertight with a modular rubber-linked mechanical pipe seal as manufactured by "Thunderline Corporation" under the trade name "Link-Seal" in lieu of an oakum packing and mastic waterproof seal as specified herein for all other pipe penetrations.
- J. Pipes passing through pipe sleeves below grade grouted with a waterproof cement shall not be approved in lieu of waterproof and/or watertight methods specified herein.

- K. Install sleeves for pipes passing through concrete and masonry walls, gypsum-board partitions, concrete floor and roof slabs, and where indicated.
1. Cut sleeves to length for mounting flush with both surfaces. Exception: Extend sleeves installed in floors of mechanical equipment areas or other wet areas 2 inches (50 mm) above finished floor level. Extend cast-iron sleeve fittings below floor slab as required to secure clamping ring where specified.
 2. Build sleeves into new walls and slabs as work progresses.
 3. Install large enough sleeves to provide 1/4-inch (6 mm) annular clear space between sleeve and pipe or pipe insulation. Use the following sleeve materials:
 - a. Steel Sheet-Metal Sleeves: For pipes 6 inches (150 mm).
 - b. Steel Sheet-Metal Sleeves: For pipes 6 inches (150 mm) and larger that penetrate gypsum-board partitions.
 - c. Cast-Iron Sleeve Fittings: For floors having membrane waterproofing. Secure flashing between clamping flanges. Install section of cast-iron soil pipe to extend sleeve to 2 inches (50 mm) above finished floor level. Seal space outside of sleeve fittings with nonshrink, nonmetallic grout.
 - d. Except for below-grade wall penetrations, seal annular space between sleeve and pipe or pipe insulation, using elastomeric joint sealants.
- L. Above Grade, Exterior Wall, Pipe Penetrations: Seal penetrations using sleeves and mechanical sleeve seals. Size sleeve for 1-inch (25 mm) annular clear space between pipe and sleeve for installation of mechanical seals.
1. Install steel pipe for sleeves smaller than 6 inches (150 mm).
 2. Install cast-iron wall pipes for sleeves 6 inches (150 mm) and larger.
 3. Assemble and install mechanical seals according to manufacturer's printed instructions.
- M. Below Grade, Exterior Wall, Pipe Penetrations: Install cast-iron wall pipes for sleeves. Seal pipe penetrations using mechanical sleeve seals. Size sleeve for 1-inch (25 mm) annular clear space between pipe and sleeve for installation of mechanical seals.
- N. Fire Barrier Penetrations: Maintain indicated fire rating of walls, partitions, ceilings, and floors at pipe penetrations. Seal pipe penetrations with firestopping sealant material. Install products to form a penetration system contained in UL Fire Resistance Directory. Provide UL detail to authority having jurisdiction if requested.
- O. Verify final equipment locations for roughing in.

2.9 ESCUTCHEONS

- A. Brass, chrome-plated, securing-type escutcheons shall be provided at all exposed, finished surfaces pierced by sleeves or pipes. They shall fit around insulation or around pipe if uninsulated and shall extend against the finished wall, floor or

ceiling surface so that the sleeve is completely concealed unless specified otherwise herein.

- B. All work sink piping penetrating finished walls shall be fitted with hinged chrome-plated, steel securing-type escutcheons Sanitary-Dash #99-G on waste piping and shallow one-piece, chrome-plated, steel securing-type escutcheons Sanitary- Dash #R392 on supply piping.

2.10 HANGERS AND SUPPORTS

- A. Plumbing Contractor shall support all piping from building structure by means of approved hangers and supports. Piping shall be supported to maintain required grading and pitching of lines, to prevent vibration and to secure piping in place, and shall be so arranged as to provide for expansion and contraction.
- B. Do not hang pipe hangers from bottom chord of roof joists. Hangers must be installed at or within 6" of panel point of roof joists. 6" and larger pipes running parallel to roof joints must be supported by two roof joists. Plumbing Contractor shall furnish and install angle iron bridging between joists of adequate size to securely support pipe hanger. Bridging for pipe hangers must be supported by the top chord of the roof joist and must be installed at or near panel point.
- C. Select, provide, fabricate and install pipe hangers and supports complying with MSS SP-58, MSS SP-69 and MSS SP-89 (Manufacturers Standardization Society of the Valve and Fittings Industry, Inc.). Provide product which is UL-listed and FM approved.
- D. No piping shall be installed using hangers, supports or supplementary steel of other trades.
- E. Hangers and supports shall be designed and installed so that no load will be transmitted to equipment connections.
- F. Chain, strap, perforated bar or wire hangers will not be acceptable. No hangers or supports shall be attached to steel decks, ductwork, piping, conduit and/or equipment of other trades.
- G. Drilling of building structural steel for attachment of hangers or supports is not permitted under any circumstances. Welding to building structural steel is permitted only where specified or specifically indicated on the drawings. When special conditions arise, shop drawings and/or other descriptive information detailing proposed methods of welding hinges, supports, or anchors shall be submitted for written approval by Engineer prior to welding.
- H. Hangers, supports, and/or pipe requiring bridging shall originate at or transmit the load to/or near panel points along top cord of trusses, girders and/or roof joists when hung from such members. Do not hang from bottom chord of such members.

- I. Where overhead construction does not permit fastening of hanger rods in required locations, provide additional steel framing as required and approved. Supplemental (support) steel shall be in accordance with AISC specifications for design fabrication and erection of structural steel for building piping running parallel with roof joists.
- J. Floor stands may be used on piping running close to floor. Threaded rod alone will not be acceptable for support of said piping.
- K. Piping buried in ground shall have a firm bearing along its entire length on undisturbed or compacted earth or shall be supported from slab above as specified herein. Support and protect underground piping so that it remains in place without settling and without damage during and from backfilling. Replace any piping so settling or so damaged.
- L. All vertical piping throughout the building shall be securely fastened and supported at each floor, ceiling and roof by means of approved steel supports (firmly attached to the building structure and to the pipe) or steel riser clamps (install above slab and resting on the floor sleeve). The foot of each stack and/or leader shall be firmly supported.
- M. Horizontal pipe runs of ferrous pipe shall be supported from the structure above by a steel clevis hanger which provides a vertical adjustment of approximately 1-1/2" after the pipe is in place by means of a suspended steel rod and two (2) locking hex nuts. Such piping shall be attached to the structure by means of an approved heavy "C" camp with safety retaining clip or by side beam connections to steel and/or with approved expansion bolts to concrete wall.
- N. Where pipes are supported from the side wall, hangers shall be clevis type (as specified above) with approved steel angle brackets, bolts and expansion shields.
- O. Horizontal runs of water piping shall be supported from the structure above by clevis hangers. Perforated channel systems with top-mounted securing clamps shall not be permitted. Perforated channel shall be permitted for a trapeze design from which clevis hangers may be hung.
- P. Clevis hangers and/or split ring hangers in contact with copper pipe shall be isolated or finished in copper to match the piping and/or of brass construction. Field painting or spraying of hangers, rods, and nuts in lieu of copper plating will not be accepted.
- Q. All hangers and supports provided for all piping materials specified herein, shall be as specified herein and/or in accordance with State Codes and Regulations which ever more stringent.
- R. Provide pipe hangers, clamps and components with copper coating for electrolytic protection where attachments are in direct contact with copper tubing and plastic coating for use with plastic pipes.

- S. Provide hangers at a maximum distance of 2' from all changes in direction (horizontal and vertical) on both sides of concentrated loads independent of the piping.
- T. All hangers and supports shall be spaced at intervals as specified herein and/or in accordance with State Codes and/or Regulations requiring closer hanger spacing. Maximum spacing of hangers on soil pipe shall be 5' and hangers shall be provided at all changes in direction. For pipes exceeding 5'-0" length, they shall be placed at intervals equal to the pipe length but not exceeding 10'-0". Hangers for No-Hub piping shall be provided at least at every other joint except when the developed length between hangers exceeds 4'-0" in such case they shall be provided at each joint.
- U. All supplementary steel including factory fabricated channels, brackets and/or supports and associated accessories throughout the project for this Section of the Specifications both suspended and floor mounted shall be furnished and installed by the Plumbing Contractor and shall be subject to the approval of the Architect and Owner prior to fabrication and installation.
- V. Shop drawings and/or material in specification sheets detailing supplementary steel between joists for pipes over 2", wall supports for exterior gas risers equipment and/or accessories specified herein shall be submitted to the Engineer and Owner Engineering Department for approval prior to fabrication and installation.
- W. All copper water piping penetrating through metal studs shall be fitted with standard polybutylene metal stud insulator inserts manufactured by "Holdrite" or approved equal. Hole sizes drilled through metal studs shall accommodate the proper insulator insert and pipe size.
- X. All metal or galvanized steel brackets used for rough-in of water piping shall be copper plated or provided with standard PEX insulator inserts manufactured by "Holdrite" or approval equal.
- Y. All hangers on insulated lines shall be sized to fit the outside diameter of the pipe insulation. Pipe insulation shields shall be provided at all hangers on insulated piping "Carpenter & Paterson Fig. #265P". Provide 18-gage, 12" long, galvanized steel sheet metal shields, formed to a 180° arc at all pipe hangers on insulated water and condensate piping specified herein.
- Z. All pipe insulation shields specified herein shall be secured and welded in place at its mid-point to each respective clevis hanger.
- AA. Hangers in general for all horizontal piping shall be "Carpenter & Paterson Fig. #100B clevis type hangers. These hangers shall be sized to provide for insulation shields as specified herein.
- BB. Roughing for water supplies to all fixtures, equipment, specialties and components specified herein shall be firmly secured at the base of all elbows

turning out through finished wall. Plumbing Contractor shall give special consideration to securing hot and cold water supplies serving hose bibs and fixtures with flush valves as specified herein.

- CC. Perforated channel shall not be accepted for support of ferrous pipe in lieu of steel angle or channel.
- DD. Plumbing Contractor shall furnish and install "Super Strut" Series #A-1200-HS, 12-gage, half-slotted, electroplated zinc-coated metal framing channels with pipe strap #703 1-1/2, 14-gage pipe straps to support the shielded nutrient feed/non-potable water piping systems specified herein. Steel channels may be hung from the overhead and/or fastened to the walls.
- EE. Plumbing Contractor shall provide an approved blocking material (oak wood blocking or high density fiberglass "H" block) to be used in the support of insulated storm drainage systems inserted at each hanger location sized a minimum of 6" long and equal in thickness to said insulation.
- FF. All branch piping shall have separate supports, no branch piping 5'-0" or longer shall be without support.
- GG. All piping sized 6" and larger running parallel with the roof joists shall be supported by two (2) roof joists. Plumbing Contractor shall furnish and install angle iron bridging between joists of adequate size to securely support the pipe hangers. Bridging for pipe hangers shall be supported by the top chord of roof joists and shall be installed at or near roof joist panel points.
- HH. Piping at all equipment and control valves shall be supported to prevent strains or distortion in the connected equipment and control valves. Piping at equipment shall be supported to allow for removal of equipment, valves and accessories with a minimum of dismantling and without requiring additional support after these items are removed.
- II. All suspended horizontal piping shall be supported from the building by approved continuously threaded, mild steel rods connecting the pipe hangers to beam clamps, angle brackets, lag screws and/or inserts.
- JJ. Beam clamp retaining straps shall be provided when required by State Code, Seismic Codes.
- KK. Plumbing Contractor shall remove all wooden supports, concrete blocks, bricks, etc., from beneath all piping joints prior to backfilling and compacting of soils around piping.
- LL. Plumbing Contractor shall provide corrosion resistant hanger assemblies, clevis hangers, rods, nuts, washers and anchor plates when supporting piping below grade for site subject to poor soil conditions.

- MM. Plumbing Contractor shall provide wood blocking (oak wedges) for support of clevis hangers located below grade prior to backfill of underground piping for sites with poor soil conditions requiring pipe support from slab above so as to prevent hangers from dropping down from and out of contact with the pipe prior to and / or during the backfilling and compaction of piping.
- NN. Plumbing Contractor shall provide supply pipe support assemblies with each water closet and urinal carrier used for securing water supply piping serving each flush valve in lieu of wood blocking.
- OO. Plumbing Contractor shall utilize expansion bolts for the securing of all fixture carriers specified herein; powder actuated fasteners, expansion shields and/or inserts shall not be used in lieu thereof.
- PP. All water piping secured directly to the exterior walls with split ring hangers and plates shall be thermally isolated with plywood blocking (5" x 5" x 3/4") place between the exterior wall and the hanger plates.
- QQ. All split ring hanger screws shall be installed securely in place with a "locktite" compound on their threads.
- RR. Submittals:
1. Submit pipe hanger and support schedule showing manufacturer's Figure Number, size, location, and features for each required pipe hanger and support.
 2. Welder certificates, where applicable, signed by Contractor certifying that welders comply with requirements specified under the "Quality Assurance" Article.
 3. Shop drawings for each type of hanger and support, indicating dimensions, weights, required clearances, and methods of component assembly.
- SS. Quality Assurance:
1. Licensed Engineer: Contractor is to secure the services of a licensed engineer to prepare hanger and support design drawings, and calculations for seismic restraint of piping and equipment. Include seal and signature of Registered Engineer, licensed in jurisdiction where project is located, certifying compliance with specifications.
- TT. Install hangers for horizontal piping spacing and minimum rod sizes per the Uniform Plumbing Code, table 3-2 Hangers and Supports.
- UU. Support plastic pipe and tubing not included in table according to manufacturer's recommendations.
- VV. Arrange for grouping of parallel runs of horizontal piping supported together on field-fabricated, heavy-duty trapeze hangers where possible. Clamp all piping to support; maintain spacing and alignment.

- WW. Install supports with maximum spacings as specified in individual piping sections. Provide additional hangers or supports within two feet of elbows, tees or change of direction.
- XX. Where pipes of various sizes are supported together by trapeze hangers, space hangers for smallest pipe size or install intermediate supports for smaller diameter pipes as specified above for individual pipe hangers.
- YY. Install building attachments within concrete or to structural steel. Space attachments within maximum piping span length indicated. Do not support piping from metal deck; Provide miscellaneous steel to span between beam or joist. Install additional attachments at concentrated loads, including valves, flanges, guides, strainers, expansion joints, and at changes in direction of piping. Install concrete inserts before concrete is placed; fasten insert to forms. Install reinforcing bars through openings at top of inserts. Attach to steel beams with beam clamps and clips; to joist by through bolting web with two-inch-square heavy washers.
- ZZ. Install powder-actuated drive-pin fasteners in concrete after concrete is placed and completely cured. Use operators that are licensed by powder-actuated tool manufacturer. Install fasteners according to powder-actuated tool manufacturer's operating manual. Do not use in lightweight concrete slabs or in concrete slabs less than 4 inches (100 mm) thick.
- AAA. Install mechanical-anchor fasteners in concrete after concrete is placed and completely cured. Install according to fastener manufacturer's written instructions. Do not use in lightweight concrete slabs or in concrete slabs less than 4 inches (100 mm) thick.
- BBB. Install hangers and supports complete with necessary inserts, bolts, rods, nuts, washers, and other accessories.
- CCC. Heavy-Duty Steel Trapezes: Field-fabricate from ASTM A36 steel shapes selected for loads being supported. Weld steel according to AWS 0-1.1.
- DDD. Install hangers and supports to allow controlled movement of piping systems, permit freedom of movement between pipe anchors, and facilitate action of expansion joints, expansion loops, expansion bends, and similar units.
- EEE. Load Distribution: Install hangers and supports so that piping live and dead loading and stresses from movement will not be transmitted to connected equipment.
- FFF. Shields: Install MSS Type 40, protective shields on cold piping with vapor barrier. Shields span an arc of 180 degrees (3.1 rad) and have dimensions in inches (mm) not less than the following:

<u>NPS (Inches)</u>	<u>LENGTH (Inches)</u>	<u>THICKNESS (Inches)</u>
1/4 to 3-1/2	12	0.048
4	12	0.060
5 and 6	18	0.060
8 to 14	24	0.075
16 to 24	24	0.105

GGG. Pipes 2 inches (240 mm) and Larger: Include thermal inserts.

HHH. Insert Material: Length 1 inch longer than protective shield.

III. Equipment Supports: Fabricate structural steel stands to suspend equipment from structure above or support equipment above floor.

JJJ. Hanger Adjustment: Adjust hangers to distribute loads equally on attachments and to achieve indicated slope of pipe.

KKK. Painting – Touchup: Clean field welds and abraded areas of shop paint and paint-exposed areas immediately after erection of hangers and supports. Use same materials as used for shop painting.

LLL. Galvanized Surfaces: Clean welds, bolted connections, and abraded areas and apply galvanizing-repair paint to comply with ASTM A780.

2.11 SEISMIC HANGERS AND RESTRAINTS

A. All pipe hangers and equipment supports to be constructed and installed in accordance with Zone requirements as outlined in the State Building Code.

B. Plumbing Contractor shall submit one (1) copy of the shop drawings and calculations detailing seismic hanger restraints to State Building Authority, Engineer, and Owner, along with a letter of compliance stamped and signed by a registered structural engineer confirming that the piping hangers meet the State seismic code requirements.

C. Cable provided for seismic systems shall be color coded and prestressed.

D. All beam clamps shall be secured with retaining straps for all piping systems requiring seismic restraints.

2.12 CLEANOUTS

A. General: Size cleanouts as indicated on drawings, or where not indicated, same size as connected drainage piping. Cleanouts larger than 4 inches are not required except where indicated.

1. Cleanout Plugs: Comply with Plumbing Code, with American Standard pipe threads.

2. Cleanouts in Floor with Resilient Tile and Sheet Finish: Wade W-6000-D-5.
 3. Cleanouts in Floor with Ceramic Tile Finish: Wade W-6000- TS-5.
 4. Cleanouts in Finished Rooms Flush with Wall: Wade W-8460-S-5 stainless steel.
 5. Cleanouts on lines in completely accessible pipe chases or in equipment rooms where piping is exposed do not require special covers.
 6. Cleanouts in Floors with Carpet: Wade W-6000-CM-5.
 7. Cleanouts for Concrete or Terrazzo Finish: Wade W-6000-5.
 8. Cleanouts for Exterior at Grade: Wade W-6000-X-5.
- B. Accessible cleanouts shall be provided for all sanitary, storm and condensate drainage piping systems, at the base of all stacks (above slab), all changes in direction, the ends of lines, at exterior walls prior to leaving the building, and not more than 50 feet apart in runs of horizontal and vertical pipe.
- C. All cleanouts shall be of same size as pipe installed up to 4" in diameter, and not less than 4" in diameter for piping larger than 4" in diameter.
- D. Cleanouts on concealed piping below slab shall be extended through and terminated flush with finished floor.
- E. All floor cleanouts shall have cast-iron bodies with flush, heavy duty, scoriated, polished nickel bronze tops.
- F. Wherever cleanouts on vertical lines occur concealed behind finished walls, they shall be extended to back of finish wall and be provided with a bronze plug and round stainless steel access cover and screw. The access cover shall be sized to permit removal of cleanout plug.
- G. All floor cleanouts shall be made accessible and located so as not to fall under or below refrigerated cases, shelving, or equipment.
- H. Where possible, dandy cleanout or test tee fittings shall be installed at the base of all roof conductors (above finished floor). Wye branch cleanouts fittings shall not be used in lieu thereof.
- I. Approved Manufacturers: Smith, Wade, Zurn.

2.13 ACCESS AND ACCESS PANELS

- A. All work by Plumbing Contractor shall be performed so as to provide proper access to material or equipment which may need inspection, replacement, repair or service. If proper access cannot be provided, confer with Architect as to best method of approach to minimize effect of reduced access which may result.
- B. Furnish access panels where any traps, valves, specialties, and/or other items specified herein which require access are concealed in floors, walls, furred spaces or above ceilings.

- C. Access panel finish shall be coordinated with the Architect.
- D. Ceilings consisting of lay-in or removable splined tiles do not require access panels. Valves above ceiling shall have locations marked with thumb tacks on finished ceiling panels; locations shall be noted on record drawings.

2.14 FLOOR DRAINS, ROOF DRAINS, AREA DRAINS AND TRENCH DRAINS

- A. General:
 - 1. Installation of floor drains in areas and locations as called for on drawings.
 - 2. Equal drains as manufactured by Smith, Josam and Wade are acceptable.

2.15 HEAT TRACING

- A. Provide electrical heat tracing as indicated on drawings. Systems shall consist of a heating element, controls, components and mounting hardware. Systems shall be UL listed and approved by FM for this specific type of duty.
- B. Heater shall operate on 208 or 277 volts without the use of transformers.
- C. Heater shall be UL listed for this specific application and be manufactured by Raychem Corp or approved equal.
- D. Power connection, end seal, splice, outer jacket repairs, and installation devices shall all be field installed.
- E. Power shall be supplied using a GFCI breaker with a 30 milliamp trip.
- F. Protect the heater from physical damage.
- G. Install in accordance with all manufacturer's instructions.
- H. Tracing used in gutters and downspouts shall be extended down the leaders to below the surface of the ground, or until the leader goes inside the insulation envelope. Heat trace piping that enters ground to a minimum depth of 3 feet below grade.
- I. Acceptable Manufacturer: Raychem or approved equal.

2.16 INSULATION

- A. General:
 - 1. All insulation coverings specified herein for piping systems and equipment shall be continuous with side joints staggered and end joints tightly butted, installed per manufacturer's recommendations, in a workmanlike manner, by a "Pipe Covering Contractor" employing skilled workmen regularly engaged in this type of work.

2. All pipe insulation covering, PVC covers, tape, adhesives, mastics, cements shall have a composite smoke and fire rating not exceeding that of NFPA 90A (Flame Spread - 25, Smoke Developed - 50).
3. All pipe insulation covering PVC covers and accessories, etc., shall be kept dry prior to and during installation.
4. All insulated pipe with temperatures below ambient temperature shall have a continuous vapor barrier. All joints, seams, and fittings must be sealed to prevent condensation.
5. Tapes, adhesives, mastics, cements and/or coatings shall be applied when subject to temperature below 40°F.
6. Before pipe covering is applied, all pressure tests shall have been performed and approved, with all piping surfaces to be covered having been cleaned.
7. Valves, fittings, flanges and piping accessories shall have the same thickness of pipe insulation as adjacent pipe.
8. All valves shall be insulated up to packing gland.
9. All pipe insulation jackets specified herein, shall have a continuous pressure sealing adhesive cap along its entire length. Staples, tacks and/or bands shall not be acceptable methods of sealing or fastening insulation jackets and/or PVC covers specified herein.
10. Following the installation of wood blocking at hanger locations supporting horizontal storm drainage piping, all insulation jackets shall be replaced and sealed with a vaporproof mastic.
11. Insulate all handicapped lavatory supplies and waste piping with flexible molded vinyl coverings as specified herein. Elastomeric, fiberglass, and/or foam pipe insulations or coverings shall not be permitted in lieu thereof.
12. Submit manufacturer's technical product data and installation instructions for each type of mechanical insulation. Submit schedule showing manufacturer's product number, k-value, density, thickness, and furnished accessories for each mechanical system requiring insulation.

B. Materials (All materials shall be selected in accordance with State Plumbing Code and regulations):

1. Hot Water Piping: Hot water piping shall be insulated with molded, rigid, sectional fiberglass, 3-1/2 lbs per cubic feet density, (K-value of .23 at 75° mean temperature), with a white all-purpose jacket (vapor barrier) composed of kraft bonded to aluminum foil, reinforced with fiberglass yarn and self-sealing lap.
2. Fittings and valves shall be covered with insulating material equal in thickness to that of adjoining pipe insulation and jacketed with approved white, preformed PVC covers. An alternate vapor proof canvas or glass cloth jacket with a vapor proof mastic (insulating cement) shall not be used on fittings and valves in lieu thereof.
3. Fiberglass pipe insulation installed outdoors shall be jacketed as specified for indoors and finished with a moisture retarder and metal jacket. Moisture retarder shall be 3 mil Dupont Surlyn or 20 mil, high-impact, ultraviolet-resistant PVC. Metal jacket shall be aluminum, ASTM B209, 3003 alloy, H-14 temper with smooth finish, 0.016-inch thick.

- C. Cold Water Piping (Above Slab): Cold water piping, valves, and fittings shall be insulated as specified for Hot Water Piping. In addition, all joints shall be sealed with a white or colorless vapor adhesive.
- D. Cold Water Piping (Below Slab): Cold water piping, fittings, and valves shall be insulated with 1/2" flexible, elastomeric, tubular pipe insulation (K-value of .27 at 75°F mean temperature and water vapor permeability of .17 perm-in). All joints shall be glued with an approved adhesive recommended by insulation manufacturer.
- E. Storm Drainage (Above Slab): All horizontal runs of storm drainage piping and fittings including all horizontal and vertical piping and fittings above finished ceilings shall be as specified herein for Hot Water Piping. Roof drain bodies and fittings shall be covered with insulating material equal in thickness to that of adjoining pipe insulation and jacketed with approved white preformed PVC covers. An alternate vapor proof canvas, glass cloth jacket with vapor proof mastic (insulating cement) and/or fiberglass duct wrap shall not be used in lieu thereof.
- F. Handicap Lavatories (Exposed Piping): Handicap lavatory supplies and waste (exposed) shall be insulated with Truebro, "Handi Lav-Guard" Insulation Kits Model #102W, white fully molded flexible vinyl insulation system complete with nylon fasteners for P-Trap and angle valve assemblies and Accessory #105 for 5" offset strainer assembly.
- G. Insulation Thickness: All minimum pipe insulation thickness shall be selected in accordance with ASHRAE Standard 90A-1980 (as specified below) and/or State and ordinances governing such work, of which the more stringent standard shall apply.

Service	Pipe Size	Nominal Thickness
Hot Water Piping: 1. Non-circulating runouts: 2. Circulating mains and runouts:	Up to 1" Up to 2"	1" 1"
Hot Water Piping (Below Slab): Designated mains and runouts:	Up to 1"	1"
Cold Water Piping (Above Slab): Mains and runouts:	Up to 2"	1"
Cold Water Piping (Below Slab): Mains and runouts:	Up to 2"	1"
Storm Drainage Piping (Above Slab): Horizontal and vertical runs:	All sizes	1"
Condensate Drains (Above Slab): Horizontal and vertical runs:	All sizes	1/2"
Handicap Lavatories (Exposed Piping): Supplies and waste:	As specified herein.	

- H. Insulation Inspection:
1. Examine areas and conditions under which mechanical insulation is to be installed. Do not proceed with work until unsatisfactory conditions have been corrected in manner acceptable to installer.
 2. Do not insulate pipes and ductwork until pressure and leak test have been completed and approved.
- I. Installation of Piping Insulation:
1. Install insulation products in accordance with manufacturer's written instructions, and in accordance with recognized industry practices to ensure that insulation serves its intended purpose.
 2. Install insulation on pipe systems subsequent to installation of heat tracing, painting, testing, and acceptance of tests.
 3. Install insulation materials with smooth and even surfaces. Insulate each continuous run of piping with full-length units of insulation, with a single cut piece to complete run. Do not use cut pieces or scraps abutting each other.
 4. Clean and dry pipe surfaces prior to insulating. Butt insulation joints firmly together to ensure a complete and tight fit over surfaces to be covered.
 5. Maintain integrity of vapor-barrier jackets on pipe insulation, and protect to prevent puncture or other damage. Seal all tears, punctures and other penetrations in insulation jacket.
 6. Cover valves, fittings and similar items in each piping system with equivalent thickness and composition of insulation as applied to adjoining pipe run. Install factory molded, precut or job fabricated units (at installer's option).
 7. Extend piping insulation without interruption through walls, floors and similar piping penetrations, except where firestopping is required.
 8. Butt pipe insulation against pipe hanger insulation inserts. For hot pipes, apply 3-inch wide vapor barrier tape or band over the butt joints. For cold piping apply wet coat of vapor barrier lap cement on butt joints and seal joints with 3-inch wide vapor barrier tape or band.
 9. The insulation shall be installed so that it does not interfere with the functioning of flexible connections or expansion joints.
 10. Piping Exposed to Weather: Protect outdoor insulation from weather by installation of weather-barrier mastic protective finish and aluminum jacketing. Install jacket with 2-inch overlap, secured by aluminum bands 9 inches OC. All rivets or screws on longitudinal seams shall be rotated away from view. Protect fittings in a like manner.
- J. Protection and Replacement: Replace damaged insulation which cannot be repaired satisfactorily, including units with vapor barrier damage and moisture saturated units. Insulation installer shall advise Contractor of required protection for insulation work during remainder of construction period, to avoid damage and deterioration.

2.17 PLUMBING FIXTURES AND EQUIPMENT

- A. Fixtures shall be best quality regular selection genuine white vitreous china, acid-resisting enameled cast-iron, or stainless steel as specified; free from cracks, dents, crazes, chips, twists, discolorations, and other defects. Fixtures shall have manufacturer's guarantee label or trademark indicating first quality. Acid resisting (AR) enameled ware shall bear manufacturer's symbol signifying acid-resisting material. Fixtures shall be American Standard, Gerber, Kohler, Elkay, Fiat, Zurn. Toilet seats shall be Church, Olsonite, or Beneke. All fixtures shall be of the same manufacturer.
- B. Exposed pipe, fittings, traps, escutcheons, valves, valve handles, and accessories, both above and below fixtures shall be CP brass (covering tubes not permitted except as noted). Brass tubing shall not be lighter than No. 17 gage. Water supplies and drainage nipples to wall shall have cast-brass escutcheons with setscrew. Exposed fixture traps shall be equipped with cleanout plugs. Fixture water supplies shall be complete with renewable seats, composition washers, all-metal indexed handles, and loose key stops. All lavatory faucets shall be equipped with flow controls to limit the flow of water to no more than 0.5 gpm.
- C. All materials specified to be chromium plated shall be thoroughly cleaned and polished before plating and plate shall be heavily, thoroughly and evenly applied guaranteed not to strip or peel.
- D. All fixtures and equipment shall be supported and fastened in satisfactory manner. Where possible, all lavatories, vitreous hand sinks, urinals and water closets shall be supported by carriers.
- E. Thoroughly clean fixtures and fittings when directed. Fixtures shall be in perfect condition at completion of job and any fixtures not in perfect condition at completion of job due to damage during construction or any other cause, shall be replaced by Contractor at no additional charge. Replace all toilet seats which are temporarily used during construction.
- F. Plumbing Contractor shall be responsible for providing those portions of the fixtures fittings or trimming which are not provided with the fixtures but which are required for complete installation. All fixtures shall be carefully checked to determine which portions must be provided to complete installation. Where escutcheons are not furnished with plumbing fixtures, Plumbing Contractor shall supply them.
- G. Mounting height for all plumbing fixtures shall be established by Architect. Consult with Architect for determination of same before installing plumbing fixtures.
- H. Refer to architectural and plumbing drawings for quantities of fixtures to be furnished under this section of the specifications, which shall be deemed to include all plumbing fixtures shown of types described hereinafter. Final location shall be determined from architectural drawings.

- I. Trim: All trim unless otherwise specified, shall be one manufacturer.
- J. Exposed Metal Parts: Exposed metal parts of a) 1 fittings unless otherwise noted shall be polished chrome finish. Provide escutcheons for piping through wall.
- K. The following is a description of fixtures to be furnished. Plumbing Contractor will be responsible for quantities required for the job. All fixtures are to be complete with all fittings and accessories required for a complete job. All fixtures to be white unless otherwise noted.
- L. Fixture Schedule shall be as indicated on drawings.

2.18 HOT WATER HEATERS AND SYSTEM COMPONENTS

- A. The water heater shall be similar to Bradford White model LE10L3-3 or approved equal. Heater shall be rated at 5 KW, 208 Volts, 1 Phase, 60 cycle listed by Underwriters Laboratories and approved by the National Sanitation Foundation. Tank shall be 30 gallon capacity with 150 psi working pressure and equipped with dual extruded high density magnesium anodes. Thermostatic mixing valve shall be similar to Symmons model 5-200A-WV or approved equal with integral check stops, outlet volume control shut off and wall mounting bracket. Expansion tank shall be similar to Amtrol Therm-X-Trol model ST-5C or approved equal with a 2 gallon tank volume.

2.19 DOMESTIC WATER BOOSTER PUMP

- A. The domestic water booster pump shall be similar to Grundfos model CRE-10 or approved equal. Booster pump shall be rated at 66 gpm with a pressure boost of 50 psi, 1-1/2 hp motor, 208 volts, single phase and 7.5 amps.

2.20 SUMP PUMP

- A. The sump pumps shall be similar to Zoeller model 75 or approved equal. Pumps shall be rated at 11 gpm, 16 feet of head, 1/2 hp, 208 volts, single phase.

PART 3 - EXECUTION

3.1 ROUGH-IN

- A. Verify final locations for rough-ins with field measurements and with the requirements of the actual equipment to be connected.

3.2 PLUMBING INSTALLATIONS

- A. General: Sequence, coordinate, and integrate the various elements of plumbing systems, materials, and equipment. Comply with the following requirements:

1. Coordinate plumbing systems, equipment, and materials installation with other building components.
2. Verify all dimensions by field measurements.
3. Arrange for chases, slots, and openings in other building components during progress of construction, to allow for plumbing installations.
4. Coordinate the installation of required supporting devices and sleeves to be set in poured-in-place concrete and other structural components, as they are constructed.
5. Sequence, coordinate, and integrate installations of materials and equipment for efficient flow of the work. Give particular attention to large equipment requiring positioning prior to closing in the building.
6. Where mounting heights are not detailed or dimensioned, install systems, materials, and equipment to provide the maximum headroom possible.
7. Coordinate connection of plumbing systems with exterior underground and overhead utilities and services. Comply with requirements of governing regulations, franchised service companies, and controlling agencies. Provide required connection for each service.
8. Install systems, materials, and equipment to conform with approved submittal data to greatest extent possible. Conform to arrangements indicated by the Contract Documents, recognizing that portions of the work are shown only in diagrammatic form. Where coordination requirements conflict with individual system requirements, refer conflict to the Architect prior to installation.
9. Install systems, materials, and equipment level and plumb, parallel and perpendicular to other building systems and components. Piping shall be sloped as specified in individual sections.
10. Install plumbing equipment to facilitate servicing, maintenance, and repair or replacement of equipment components. As much as practical, connect equipment for ease of disconnecting, with minimum of interference with other installations.
11. Install access panel or doors where access is required behind finished surfaces.
12. Install systems, materials, and equipment giving right-of-way priority to systems required to be installed at a specified slope.

3.3 CUTTING AND PATCHING

- A. General: Perform cutting and patching in accordance with Division 1. In addition to the requirements specified in Division 1, the following requirements apply:
 1. Protection of Installed Work: During cutting and patching operations, protect adjacent installations.

3.4 PLUMBING FIXTURES - INSPECTION AND PREPARATION

- A. Contractor shall be responsible for roughing-in work of domestic water, waste and vent piping systems, verify actual locations of piping connections prior to installing fixtures. Notify the Architect in writing of unsatisfactory conditions for installation of plumbing fixtures. Do not proceed with work until unsatisfactory conditions have been corrected.

- B. Install plumbing fixtures of types indicated where shown and at indicated heights, in accordance with fixture manufacturer's written instructions, roughing-in drawings and with recognized industry practices. Ensure that plumbing fixtures comply with requirements and serve intended purposes. Comply with applicable requirements of the applicable plumbing code pertaining to installation of plumbing fixtures. See architectural drawings for exact location of plumbing fixtures.
- C. Where necessary to provide supplemental supports or anchors, provide first quality treated wood blocking in walls or ceiling as required. Provide steel members for use above the ceiling where required.
- D. Anchor plumbing fixtures securely to indicated supports or building structure and ensure that fixtures are level and plumb.
- E. Cutouts in counter tops, cabinetry and tables for fixtures and trim provided with countertop, cabinetry and tables. Coordinate exact size of all cutouts required and furnish manufacturer's standard cutout template for all sinks provided under this section.

3.5 FIELD QUALITY CONTROL

- A. Upon completion of installation of plumbing fixtures and after units are water pressurized, test fixtures to demonstrate capability and compliance with requirements.
- B. Correct malfunctioning units, then retest to demonstrate compliance; otherwise, remove and replace with new and proceed with retesting.

3.6 SANITARY WASTE SYSTEMS

- A. Plumbing Contractor shall furnish and install a complete sanitary drainage system (soil, waste and vent piping) from and including all plumbing fixtures, drains, equipment and accessories in accordance with Plumbing Construction Drawings and as specified herein.
- B. The building sanitary waste systems shall be installed in a neat manner with lines straight and parallel or at right angles to walls or column lines, with risers plumb, run piping so as not to interfere with other lines.
- C. All piping shall be run concealed where possible.
- D. All piping within building sized 4" and larger, shall pitch 1/8 of an inch per foot minimum unless otherwise noted. All piping sized 3" and smaller shall pitch 1/4" per foot.
- E. All connections to plumbing fixtures, floor drains, roof drains, etc., shall be sized as specified herein as indicated on drawing schedules.

- F. All exposed piping and trim to plumbing fixtures in finished areas shall be polished chrome-plated over brass construction (faucets, drains, supplies, fittings, valves, traps, escutcheons and any other metal parts) unless specified otherwise herein.
- G. Fixture carriers shall be provided for all vitreous china water closets, urinals and lavatories specified herein.
- H. All fixture mounting heights shall be in conformance with ADA, State Codes, Regulations and Authorities governing such work.
- I. Plumbing Contractor shall furnish and install fixture carriers to suit building conditions and/or as specified herein.
- J. All floor drains shall be furnished with a cast-iron body 3" pipe size outlet, Nickel-Bronze (Nikoloy) top, and sediment bucket unless otherwise specified herein.
- K. All exposed "P" traps shall be provided with a clean-out plug.
- L. All vents shall be concealed in walls, partitions, chases, above ceilings, etc., throughout entire store including storage areas, etc. (both finished and unfinished areas).
- M. All floor drains shall be set to the proper elevation, caulked and secured in place with concrete around drain body prior to pour, irrespective of the floor finish.
- N. All floor cleanouts located in floor areas with a smooth concrete finish shall be set to the proper elevation, caulked, and secured in place with concrete around each adjustable housing prior to pour.
- O. Sanitary waste system shall be vented as required by State Codes.
- P. All vents shall pitch toward the drain they serve.
- Q. All plumbing fixtures, drains, equipment, etc., shall be drained and vented so as to be in agreement with State Codes, Regulations and Authorities. Should there be any discrepancies, the more stringent requirements shall govern.
- R. Plumbing Contractor shall provide a clear silicone sealant bead around all plumbing fixtures specified herein, in contact with finished wall and/or floor surfaces.
- S. All floor drains and floor cleanouts shall be installed in accordance with type of floor finish. Location, elevation, orientation and plumb of said drainage fixtures and accessories shall be coordinated, field verified and approved for final installation with the General Contractor prior to slab pour. General Contractor shall indicate (for the Floor Concrete Contractor) recessed slab finishes required

to allow said items to be set flush with the finished floor type. Such approval and direction shall be witnessed by the Plumbing Contractor.

- T. All sanitary vents through roof shall terminate a minimum of 18" to a maximum 24" above the roof (or as required by State Plumbing Code).
- U. All floor cleanouts and ceiling cleanouts shall be provided with brass plugs in lieu of plastic plugs.
- V. Make changes in direction for drainage and vent piping using appropriate y branches, y branches with 1/8 bends, and long-sweep 1/4, 1/5, 1/6, 1/8, and 1/16 bends. Sanitary tees and short-sweep quarter bends may be used on vertical stacks of drainage lines where change in direction of flow is from horizontal to vertical. Use long-turn double-Y-branch and 1/8-bend fittings where 2 fixtures are installed back to back or side by side and have a common drain. Straight tees, elbows, and crosses may be used on vent lines. Make no change in direction of flow greater than 90 degrees. Where different sizes of drainage pipes and fittings are connected, use proper size standard increasers and reducers. Reduction of the size of drainage piping in the direction of flow is prohibited.
- W. Lay buried building drains beginning at low point of each system, true to grades and alignment indicated, with unbroken continuity of invert. Place hub or bell ends of piping facing upstream. Install required gaskets according to manufacturer's recommendations for use of lubricants, cements, and other special installation requirements.
- X. Install cast iron drainage pipe and fittings according to CISPI.

3.7 STORM DRAINAGE SYSTEM

- A. Plumbing Contractor shall furnish and install a complete building storm drainage system in accordance with the Plumbing Construction Drawings and as specified herein.
- B. Storm drainage piping shall be run in a neat manner with lines straight and parallel or at right angles to walls or column lines with roof conductors plumb.
- C. All piping 4" and larger, unless otherwise noted, shall pitch 1/8" of an inch per foot within the building. All piping 3" and smaller shall pitch 1/4" per foot.
- D. Horizontal runs of storm drainage piping shall be kept as high as possible to roof steel.

3.8 HOT AND COLD WATER DISTRIBUTION SYSTEM

- A. Plumbing Contractor shall furnish and install a complete hot and cold water system, including all roughing and final connections to all plumbing fixtures, accessories, specialties, components and equipment in accordance with Plumbing Construction Drawings and as specified herein.

- B. Special attention shall be given to the location of domestic water service entering the building with respect to structural details (footing and column sizes, locations and elevations, etc.).
- C. Provide a stop valve on each water supply directly under and/or in the same room as each plumbing fixture, specialty and/or accessory unless specified otherwise herein.
- D. All hot and cold water branch supplies shall have ball valves installed on each branch line off main where possible ball valves shall be located 1'-0" above finished ceiling directly above fixture or fixture group, specialties, components and/or equipment unless specified otherwise herein.
- E. Install piping in a neat manner with lines straight and parallel or at right angles to walls or column lines and with risers plumb, run piping so as to avoid passing through ductwork or directly under electric light outlets, and/or interfering with other lines. All work shall be accomplished using the best methods and procedures of recognized pipe fabrication in a good and workmanlike manner in accordance with the State Plumbing Code.
- F. Plumbing Contractor shall accept the cost of all charges necessary to obtain the required water service and meter on site from the local utility company and shall include this cost in his bid price. Main water service and meter shall be sized as shown on Plumbing Construction Drawings.
- G. Plumbing Contractor shall furnish and install a pressure reducing valve for main water service with excessive pressure as required by State Plumbing Code. Pressure reducing valve shall be set at a pressure indicated on Plumbing Construction Drawings and/or specified herein.
- H. Allowances shall be made for expansion and contraction of pipe branch connections taken from mains. Risers shall be made with swing joints and offsets to avoid undue strain on fittings or short pipe lengths. Straight horizontal runs of pipe over 50 feet in length shall be provided with expansion loops, expansion fittings shall not be provided in lieu thereof.
- I. Provide shock absorbers on all hot and cold water branch lines serving an individual fixture, fixture group and miscellaneous equipment specified herein sized and installed in accordance with Plumbing and Drainage Institute Standard "PDI WH201" and manufacturers recommendations. Where possible shock absorbers shall be located 1'-0" above finished ceiling with ball valve for each directly above fixture, fixture group, specialties, components and/or equipment unless specified otherwise herein.
- J. Plumbing Contractor shall furnish and install pressure reducing valves for all equipment specified herein, requiring operating pressures below building pressure.

- K. All piping shall be concealed in chases, partitions and above ceiling where possible. Piping shall not be permitted in masonry walls and/or chest walls.
- L. No horizontal or vertical runs of piping shall be allowed to pass over and/or through Electric, Telephone, Machinery or Equipment Rooms.
- M. Ball valves shall be substituted in lieu of gate and globe valves where State Plumbing Code allow unless specified otherwise herein.
- N. Plumbing Contractor shall furnish and install backflow preventers and vacuum breakers where required by State Plumbing Code at his own expense, unless specified otherwise herein.
- O. All lavatories, handsinks, and worksinks shall be furnished and installed with aerator flow rates as required by State Building Code and Plumbing Code.
- P. All water heaters shall be provided with dial or column type thermometers on all hot water supplies as specified herein.
- Q. Flow controls shall be provided where required by State Codes.
- R. Plumbing Contractor shall provide pressure gages downstream of all pressure reducing valves specified herein.
- S. Plumbing Contractor shall provide temperature and/or pressure relief valves for all water heaters specified herein, in accordance with State Codes and manufacturer's recommendations.
- T. Vacuum relief valves shall be provided on cold water supply to all water heaters specified herein.
- U. Plumbing Contractor shall furnish and install a pressure gage immediately downstream of domestic water meter and all pressure reducing valves as specified herein.
- V. Plumbing Contractor shall utilize only lead-free solder and flux when sweating copper water piping specified herein.
- W. Plumbing Contractor shall provide a ball valve at the expansion tank serving hot water heater as specified herein.
- X. Plumber shall provide a pressure reducing valve on the domestic water booster pump and pressure tank on the domestic water service located directly downstream of the booster pump as required for design of the domestic water system. Set to 50 psi.

3.9 PROPANE GAS SYSTEM

- A. Plumbing Contractor shall furnish and install a complete gas system from propane tanks to all gas-fired HVAC equipment in accordance with Plumbing Construction Drawings and as specified herein.
- B. Exact location of all gas-fired HVAC equipment shall be field coordinated with the General Contractor and the HVAC Contractor and shall not be scaled off the plumbing construction drawings, as they are diagrammatic.
- C. A gas valve and union coupling shall be installed in each gas line for each gas-fired unit and/or equipment specified herein. The gas valve shall be the full size of the branch line indicated on the drawings and not the final unit or equipment connection size, unless specified otherwise herein.
- D. All gas connections to equipment and piping within the building shall be installed by a licensed gasfitter so as to prevent gas seepage into building.
- E. All gas piping shall pitch towards drip pockets located at system low points. Sediment traps shall be provided at all equipment locations as required by State Gas Code. All drip pockets and sediment traps shall be at least 6" long with removable caps. All drip pockets and traps shall be located inside the building.
- F. All materials and methods used in fabrication of gas system shall be approved by the State Plumbing Code, Gas Supplier and/or authorities having jurisdiction.
- G. Piping shall be installed by a licensed gasfitter in a neat manner with lines straight and parallel or at right angles to walls or column lines and with risers plumb, run piping so as to avoid passing through duct work or directly under electric light outlets, and / or interfering with other lines. All work shall be accomplished using the best methods and procedures of recognized pipe fabrication in a good and workmanlike manner in accordance with the State Plumbing Code.
- H. No horizontal or vertical runs of gas piping shall be allowed to pass thru Electric, Telephone, Energy Management Room, and / or Compressor Room Areas, and where possible shall be routed around these areas as shown on the Plumbing Construction Drawings.
- I. Ball valves may be provided in lieu of plug valves for sizes specified herein where approved by State Codes.
- J. Gas piping shall not penetrate flues, ductwork and / or exhaust hoods.
- K. All gas piping branches shall be taken from top or sides of horizontal mains.
- L. Individual branch piping sizes shall not be reduced upon final rise or drop to individual gas-fired equipment, etc.

- M. Plumbing Contractor shall offset all gas supply piping downstream of full sized branch riser and / or drop with reducing elbow and / or reducing tee fitting prior to connecting to each individual gas-fired unit and / or equipment specified herein.
- N. Plumbing Contractor shall furnish and install reducing elbows off each full sized branch supply prior to connecting to each roof top gas-fired unit and/ or equipment.
- O. Plumbing Contractor shall furnish and install reducing tee's off each full sized branch supply prior to connecting to each gas fire unit or equipment located inside the building.
- P. All gas valves specified herein shall be provided with full port openings or equivalent areas with respect to corresponding pipe size.
- Q. Plumbing Contractor shall furnish and install gas pressure regulator vent piping as required in accordance with State code.

3.10 DISINFECTION OF DOMESTIC WATER SYSTEM PIPING

- A. All domestic water system piping in building shall be disinfected in accordance with either of the following described methods and shall be performed in the presence and to the satisfaction of the Plumbing Inspector:
 - 1. The system of parts thereof, shall be filled with a solution containing 50 parts per million of available chlorine and allowed to stand 24 hours before flushing.
 - 2. The system, or part thereof, shall be filled with a solution containing 200 parts per million of available chlorine and allowed to stand 1 hour before flushing.
 - 3. Notice shall be given forty-eight hours in advance of all dates and times for sterilization of all system piping. Provide certificate of acceptance.

3.11 TESTS AND STERILIZATION

- A. Entire sanitary, vent, storm, water and gas systems shall be tested, flushed and/or sterilized by the Plumbing Contractor in the presence of the General Contractor, State Authorities (Plumbing Inspector and Gas Fitting Inspector if separate from Plumbing Inspector) and, when possible, Owner's Representative after completion of "rough-in" work before concealing any section from view to the complete satisfaction of the appropriate code officials in accordance with their requirements. Notice shall be given 48 hours in advance of all test dates and times.
- B. All tests shall be made as prescribed in the applicable Ordinances, Codes, etc., but at least as follows:
 - 1. Tests shall be made by filling the sanitary, storm drainage systems with water so that all piping being tested will be subject to a pressure equal to the height of the building, with a minimum of 10'-0" in height.

2. All cold and hot water piping shall be tested before being concealed and before fixtures are installed to hydrostatic pressure 200 psi, and proven tight at this pressure. Test pressure shall be held for at least one hour with no drop during the time.
 3. All gas piping shall be tested upon completion to a pressure required by State codes. In general, the system shall be tested to a pressure of 1-1/2 times the system working pressure, but not less than 3 psi. Gas piping system shall maintain the full test pressure for a period of 10 minutes. No drop in pressure shall be permitted, except that due to temperature change. All leaks shall be properly repaired and the system re-tested and proven tight. In addition, gas testing must be satisfactory to the company supplying the gas and the State Gas Inspector. The propane tank pressure and propane line pressure tests shall be by the propane supplier.
- C. Following the final slab pour within the building, Plumbing Contractor shall perform additional testing and flushing of each entire underground sanitary, storm drainage system once all said underground systems have been totally installed below grade (completely backfilled, compacted and sealed below the building slab) to detect any obstructions and/or damage to pipe, etc. of said systems following backfilling, compacting and final slab pours.
- D. Upon successful completion of testing, sterilization and flushing of each piping system specified herein, Plumbing Contractor shall submit a letter stating that all piping systems above and below ground specified herein have been approved by State Plumbing Inspector to General Contractor.

3.12 PUMP START UP SERVICE

- A. Engage a factory-authorized service representative to perform start up service.
- B. Engage a factory-authorized service representative to train Owner's maintenance personnel to adjust, operate, and maintain controls for pumps.

END OF SECTION

SECTION 15500

FIRE PROTECTION SYSTEM

PART 1 – GENERAL

1.01 RELATED DOCUMENTS

- A. Bidding Requirements, Contract Requirements and Division 1 - General Requirements all apply to this Section.
- B. Refer to other Electrical, Mechanical and Architectural Divisions of these Specifications, other Sections in this Division, and Drawings for related work which may affect the work of this Section regardless of whether or not such work is mentioned in this section.
- C. The Contract Drawings indicate and show limits of construction for this project. These Specifications specify materials and work requirements for this project. Both are complementary to each other, and both shall be followed to properly complete the work.
- D. In the event that the Bidding Requirements, Contracting Requirements, and Division 1—General Requirements conflict with the terms and conditions of the Contract between the Owner and the Contractor (hereinafter referred to as the Contract), the Contract shall prevail.

1.02 SUMMARY

- A. This Section specifies a new FM-200 clean agent fire suppression system for the rooms indicated on the floor plans. Materials and equipment specified in this Section include:
 - 1. Pipe, fittings, valves, panels, horns, strobes, specialties, etc.
 - 2. Nozzles, tanks, agent and accessories.
 - 3. Control devices
- B. Products furnished but not installed include nozzle cabinet with 180 deg. And 360 degree spare nozzles. Furnish to the Owner's maintenance personnel.

1.03 DEFINITIONS

- A. Pipe sizes used in this Specification are Nominal Pipe Size (NPS).
- B. Other definitions for fire protection systems are listed in NFPA Standards 2001, 76, and 72.
- C. Working Plans as used in this Section means those documents (including drawings and calculations) prepared pursuant to the requirements contained in NFPA 2001, 76 and 72 for obtaining approval of the authority having jurisdiction.

1.04 SYSTEM DESCRIPTION

- A. FM-200 systems shall be provided and installed as indicated on drawings and specified herein. System shall be provided and installed in accordance with NFPA 2001, 76 and 72.

1.05 SUBMITTALS

- A. Product Data for all products and equipment provided for the FM200 system which include, panels, nozzles, strobes, horns, alarm devices and all piping.
- B. Drawings prepared in accordance with NFPA 2001 identified as “Working Plans,” including calculations where applicable, and which have been approved by the authority having jurisdiction.
- C. Maintenance Data for each type of discharge nozzle, valve, piping specialty, fire protection specialty for inclusion in operating and maintenance manual.
- D. Welders’ qualification certificates.
- E. Test Reports and Certificates include “Contractor’s Material & Test Certificate for Aboveground Piping” as described in NFPA 2001.

1.06 QUALITY ASSURANCE

- A. Installer Qualifications: Installation and alterations of FM-200 clean agent piping, equipment, specialties, and accessories, and repair and servicing of equipment shall be performed only by a qualified installer. The term qualified means experienced in such work (experienced shall mean having a minimum of 5 previous projects similar in size and scope to this project), familiar with all precautions required, and has complied with all the requirements of the authority having jurisdiction. Upon request, submit evidence of such qualifications to the Architect. Refer to Division-1 Section: “Definitions and Standards” for definitions for “Installers.”
- B. Qualifications for Welding Processes and Operators: Comply with the requirements of AWS D10.9, Specifications for Qualifications of Welding Procedures and Welders for Piping and Tubing, Level AR-3.”
- C. Regulatory Requirements: Comply with the requirements of the following codes:
 - 1. NFPA 2001—Standard for the Installation of Clean Agent Systems (2015 edition).
 - 2. NFPA 72 – National Fire Alarm Code (2016 edition)
 - 3. NFPA 76 – Standard for the protection of Telecommunications Facilities (2016 edition)
 - 4. UL and FM Compliance: Fire protection system materials and components shall be Underwriter’s Laboratories listed and labeled, and Factory Mutual approved for the application anticipated.
 - 5. Maine State Building Code.

1.07 SEQUENCING AND SCHEDULING

- A. Schedule rough-in installations with installations of other building components.

1.08 EXTRA MATERIALS

- A. Valve Wrenches: Furnish to Owner, 2 valve wrenches for each type of clean agent discharge nozzle installed.
- B. Nozzles and Cabinets: Furnish three extra nozzles of each style included in the project. Furnish each style with its own nozzle cabinet and special wrenches as specified in this Section.
- C. One spare set of fuses of each type and size required, and 2% of the total number of smoke sensors, but not less than two thereof, shall be furnished.

PART 2 - PRODUCTS

1.09 FM-200 FIRE SUPPRESSION SYSTEM

A. General

- 1. Furnish and install a complete fully functional FM-200 Fire Suppression and Detection System, including charged FM-200 storage cylinders, nozzles, control panel, detectors, wiring, annunciators, alarms and all other equipment for a complete operational system.
 - a. The control panels, power supplies and battery capabilities must be sufficiently sized additionally to incorporate the future fit-up suppression and detection systems.
- 2. The extinguishing systems shall provide release of FM-200 agent based on the concept of total flooding fire protection for the zones indicated on the drawings. A uniform extinguishing concentration of seven percent (7 percent) shall be created within the space by the release of a pre-determined amount of FM-200 agent.
- 3. The Analog Intelligent detection system shall provide an integrated system of automatic devices. The devices, along with manual stations, abort stations shall be used to activate a control panel. This panel shall process all inputs, sequence the levels of alarm and provide for outputs to the FM-200 agent storage cylinders. Auxiliary outputs shall be furnished to shut down ventilation, activate dampers, contact other agencies or annunciate on remote devices and communicate with fire alarm control panel.
- 4. All equipment shall perform as part of a single system. The system design shall conform to all standards as described in NFPA 2001, NFPA 76 and NFPA 72 and the "Authority Having Jurisdiction".
- 5. The Contractor shall supply and install all specified equipment and accessories for a complete, electrically supervised system as described and shown on the plans.
- 6. Equipment and accessories furnished by the contractor shall be the standard components of a specified.

B. FM-200 Agent

- 1. The extinguishing agent FM-200 (HFC-227 ea), shall be heptafluoropropane. It shall exhibit no ozone depleting potential, nor contribute unique chemical species with extended atmospheric lifetimes. The agent shall be listed as acceptable for

use in normally occupied spaces by the U.S. Environmental Protection Agency, and listed in the NFPA 2001 standard.

C. Storage Cylinders

1. The cylinders shall be constructed, tested, and marked in accordance with Dept. of Transportation Specifications. As a minimum, the cylinders must meet the requirements of DOT 3AA1800.
2. Cylinder assembly shall be of steel construction with a red standard finish. Each is equipped with a pressure operated discharge valve, equipped with a pressure gauge and a liquid level indicator.

D. Distribution Piping

1. Piping for the distribution system shall be black steel pipe (ASTM A53 or A106) Schedule 40. Pipe fittings shall be Malleable Iron 300# Class (ASTM 1197). All pipe and fittings shall conform to NFPA 2001.
2. Ordinary cast iron pipe, steel pipe conforming to ASTM A 120, non-metallic pipe, or cast iron fittings shall not be used.

E. Nozzles

1. The discharge nozzle shall be engineered nozzles designed to direct the discharge of the agent using stored pressure from the cylinders.

F. Control System

1. The FM-200/ Fire Alarm panel shall be a microprocessor based system capable of communicating with the following types of peripherals and accessories: smoke sensors, thermal sensors, contact monitoring modules, addressable supervised output modules, addressable releasing modules and addressable relay modules. The control panel shall be compatible of providing all zones of FM-200.
2. The system shall be capable of communicating and controlling addressable analog devices and sensors. The system shall support software zones for configuring initiating devices and output functions.
3. The system shall respond to an alarm initiating device, including analog smoke sensors within 3 seconds for a fully loaded system. Response times shall be measured from the activation of the initiating device to the activation of the associated notification appliance circuit.
4. The system shall provide an Alarm, Trouble and Supervisory Form-C Relay contact rated at a minimum of 2.0 amps @ 30 VDC.
5. The system shall provide two configurable notification appliance circuits at the FACP. Each circuit shall be rated for 2.0 amps @ 24 VDC.
6. FM-200 Control Panel shall include a full featured operator interface control and annunciation panel that shall include a LCD display, individual color coded system status LEDs and an alpha numeric keypad for field programming of the fire alarm system.
7. All programming or editing of the existing configuration program in the system shall not require use of special equipment, such as a laptop personal computer. Access to the configuration program shall be limited by use of a password security system.

8. FM-200 Control Panel shall provide the following features:
 - a. Drift compensation for analog sensors.
 - b. Sensitivity test in accordance with NFPA 72 requirements.
 - c. Maintenance alert for sensors with excessive accumulations of dust or dirt.
 - d. Alarm verification with individual counters for each sensor.
 - e. Periodic calibration of smoke sensors.
 - f. Day/Night automatic smoke sensor sensitivity adjustments.
 - g. One man walk test with optional notification appliance testing.
 - h. Two levels of adjustable pre-alarm for advanced warning.
 9. Display
 - a. An 80 character LCD display shall annunciate system conditions and program system operating parameters.
 - b. Eight status LEDs; AC Power, Fire Alarm, Pre-Alarm Warning, Supervisory, Trouble, Alarm Silence, Supervisory Silence and Trouble Silence, shall be provided.
 - c. The display unit shall provide 25 key-pad with tactile feel membrane switches which provide operational feedback. Separate keys shall be dedicated to System Reset, Step, Alarm Silence, Acknowledge, and Drill. The keypad shall be used to provide all control and programming functions for the system.
 10. Enclosures
 - a. The system shall be housed in a small footprint enclosure with dimensions not-to-exceed 22" × 14.75" × 4.5".
 - b. The enclosure shall be capable of surface mounting without requiring additional hardware.
 - c. The enclosure shall be painted either red or gray with a corrosion protective, harden finish.
 11. Power Supplies
 - a. The power supply shall operate upon either 120 VAC or 240 VAC, 50/60 Hertz and shall provide all power necessary to operate the control system.
 12. Field Programming
 - a. The system shall be programmable from the control panel without requiring use of personal computer.
- G. Strobes
1. All strobes shall meet the requirements of NFPA/ANSI standards and ADA Accessibility guidelines.
- H. Manual Release Station and Abort Station
1. Manual Release/Abort Stations shall be provided as a means of manually activating the FM-200 System. The manual pull stations shall be of the dual action design. FM-200 abort switches shall be installed where indicated on the drawings. Once activated the manual release shall not be capable of being restored to the normal operating condition without deliberate operator intervention. The Abort switch shall be of the dead-man type which requires constant pressure on the switch to maintain the abort sequence.

I. Wiring

1. Wiring for the control and detection system shall be in accordance with NEC and NFPA standards.
2. Wiring for the control and detection system and damper trip or releases shall be 16 AWG minimum 600 volt, 105 C. UL listed wire.
3. Wiring shall be run in EMT conduit, with flexible conduit used for the last 5'0" run to detectors.
4. Make wire runs continuous unless unusually long runs make splices unavoidable. Splices must be soldered; wire nuts are not acceptable.

J. Sequence of Operation, FM-200 System

1. The FM-200 system with smoke detectors located at the ceiling will operate in the following manner:
 - a. When the system senses an alarm condition in any one detector the following will occur:
 - 1) Strobe/horn combination shall pulse slowly in the effected zone.
 - 2) Alarm signal shall be sent to the building fire alarm.
 - 3) A general alarm bell will sound at the main FM200/ Fire Alarm Control Panel.
 - b. Should a second detector (in the same zone) sense an alarm condition the following will occur:
 - 1) Strobe/horn combination shall pulse fast.
 - 2) A general alarm bell will sound at the main FM200/ Fire Alarm Control Panel.
 - 3) Thirty-second discharge timer shall start.
 - 4) Fifteen-minute FM-200 exhaust lockout timer is activated via the Purge Panel.
 - 5) Upon expiration of thirty-second time delay, FM-200 shall be discharged into space.
 - 6) The AC Units shall shut down within the zone. Close all air dampers for area in alarm.
2. Upon expiration of the fifteen minute exhaust timer, the FM-200 exhaust and supply systems (dampers and exhaust fans) for each zone shall be able to be activated via a key operated purge panel switch outside of each zone.
 - a. A general trouble condition (broken wire, dirty detector, loss of power) will activate a trouble signal at the building fire alarm.
3. The smoke detectors will be wired as a "crossed zone" wired to the control panel. These zones will consist of a combination of photoelectric and ionic detectors.

K. Audio/Visual Alarms:

1. Audio/Visual alarms shall be system sensor MA/SS series with back box.

L. Clean Agent Maintenance Switch

1. Each clean agent protected room shall have a maintenance switch provided to disable the automatic release of the clean agent. The switch is to function as a localized inhibitor of the agent to be used when maintenance or repair work is

being performed that might inadvertently activate the fire alarm and suppression circuits.

- The switch shall be key operated only
- Activation of any maintenance switch shall initiate a supervisory alarm at the main fire alarm control panel.
- An amber flashing lamp will be installed at the main MSC/RNC entrance and_control room annunciator panels that will be activated when any maintenance switch is placed in the over-ride position. The flashing amber light will be de-activated when the maintenance inhibit switch is restored to its normal operating position.

M. Functional Test and Acceptance:

1. Provide services of manufacturer's trained technician to inspect the complete system and to supervise final acceptance tests.
2. Perform a complete mechanical component check to insure that the storage and distribution systems have been installed and located properly.
3. Perform a complete electrical component check to insure that the alarm and activation devices have been installed and located properly.
4. Perform a complete functional test to insure that all alarm and activation devices operate properly.
5. Perform all tests in accordance with the standards as described in NFPA 2001.
6. Perform a complete enclosure integrity test to insure that the space will be capable of maintaining the FM-200 concentration for the required hold time. If any deficiencies are discovered, which will prevent the room from being gas tight, they shall be brought to the attention of the general contractor.
7. Perform a complete piping system flow test ("Puff Test") to insure that the piping system and discharge nozzles are unobstructed.
8. Obtain approval and acceptance of system from State and insurance authorities.
9. Copies of the test results will be distributed to the owner, general contractor and AHJ.

N. Owner Training

1. Upon completion of the installation and functional testing, a meeting shall be held at the site with contractor, and Owners personnel present. The contractor shall familiarize the Owners personnel with system components, system functions and recommended procedures. At this time, a second functional test of the system will be performed, for the purpose of educating the owners personnel.
2. The contractor will provide the owner with a system checklist which the owner will sign as acceptance of the system.

O. Furnished complete Point-To-Point Installation Drawings of the system to Owner for approval. Drawings shall include piping layouts, wire and conduit layouts, panel details, wiring diagrams, batter and piping calculations and sequence of events.

PART 3 - EXECUTION

1.10 PIPE APPLICATIONS

- A. Install Schedule 40 steel pipe with threaded joints and fittings for 2 inch and smaller, and with welded joints for 2½ inch and larger.

1.11 PIPING INSTALLATIONS

- A. Locations and Arrangements: Drawings (plans, schematics, and diagrams) indicate the general location and arrangement of piping systems. So far as practical, install piping as indicated.
 - 1. Deviations from approved "Working Plans" for FM-200 piping, require written approval of the authority having jurisdiction. Written approval shall be on file with the Architect prior to deviating for the approved "Working Plans."
- B. Use approved fittings to make all changes in direction, branch takeoffs from mains, and reductions in pipe sizes.
- C. Install flanges or flange adaptors on valves, apparatus, and equipment having 2½ inch and larger connections.
- D. Hangers and Supports: Comply with the requirements of NFPA 2001. Provide protection from damage where subject to earthquake in accordance with NFPA 2001.

1.12 PIPE JOINT CONSTRUCTION

- A. Welded Joints: AWS D10.9, Level AR-3.
- B. Threaded Joints: conform to ANSI B1.20.1, tapered pipe threads for field cut threads. Join pipe, fittings, and valves as follows:
 - 1. Note the internal length of threads in fittings or valve ends, and proximity of internal seat or wall, to determine how far pipe should be threaded into joint.
 - 2. Align threads at point of assembly.
 - 3. Apply listed or approved tape or thread compound to the external pipe threads.
 - 4. Assemble joint to appropriate thread depth. When using a wrench on valves place the wrench on the valve end into which the pipe is being threaded.
 - 5. Damaged Threads: Do not use pipe with threads which are corroded, or damaged. If a weld opens during cutting or threading operations, that portion of pipe shall not be used.
- C. End Treatment: After cutting pipe lengths, remove burrs and fins from pipe ends.

1.13 CLEAN AGENT DISCHARGE NOZZLE INSTALLATIONS

- A. Use proper tools to prevent damage during installations.

1.14 FIELD QUALITY CONTROL

- A. Flush, test, and inspect FM-200 piping systems in accordance with NFPA 2001 and as outlined in this specification.

- B. Replace piping system components which do not pass the test procedures specified, and retest repaired portion of the system.

END OF SECTION

SECTION 15600

HOT WATER BOILERS

PART 1 - GENERAL

1.1 SUMMARY

- A. Section includes Water Tube Boilers with propane burners, trim, and accessories for generating hot water.

1.2 ACTION SUBMITTALS

- A. Product Data: For each type of product.
- B. Shop Drawings: For boilers, boiler trim, and accessories.
 - 1. Provide plans, elevations, sections, and mounting and attachment details.
 - 2. Include details of equipment assemblies. Indicate dimensions, weights, loads, required clearances, method of field assembly, components, and location and size of each field connection.
 - 3. Include diagrams for power, signal, and control wiring.
 - 4. Include piping diagrams and installation plans and installation layouts for all hot water piping hooked up to the boilers.
- C. Delegated-Design Submittal: For each boiler.
 - 1. Design calculations and vibration isolation base details, signed and sealed by a qualified professional engineer.
 - a. Design Calculations: Calculate requirements for selecting vibration isolators and seismic restraints and for designing vibration isolation bases.
 - b. Vibration Isolation Base Details: Detail fabrication, including anchorages and attachments to structure and to supported equipment. Include adjustable motor bases, rails, and frames for equipment mounting.

1.3 INFORMATIONAL SUBMITTALS

- A. Seismic Qualification Certificates: For boiler, accessories, and components, from manufacturer.
- B. Source quality-control reports.
- C. Field quality-control reports.
- D. Sample Warranty: For special warranty.

- E. Provide ASME stamp "H" for 160 PSIG working pressure. Provide report certifying boilers by Authority Having Jurisdiction.
- F. Scaled coordination drawings.

1.4 CLOSEOUT SUBMITTALS

- A. Operation and maintenance data.

1.5 WARRANTY

- A. Manufacturer's Warranty: Manufacturer agrees to repair or replace controls and heat exchangers of boilers that fail in materials or workmanship within specified warranty period.
 - 1. Warranty Period for Controls: 1 years from date of Boiler startup and commissioning.
 - 2. Warranty Period for Heat Exchangers: 10 years from date of Substantial Completion.

1.6 DELIVERY HANDLING, & STORAGE

- A. Provide storage and handling facilities for boilers and accessories.

PART 2 - PRODUCTS

2.1 PERFORMANCE REQUIREMENTS

- A. Electrical Components, Devices, and Accessories: Listed and labeled as defined in NFPA 70, by a qualified testing agency, and marked for intended location and application.
- B. Emissions Limitations: Based on Region I for EPA regulations, for Natural Gas, and Propane Gas, the maximum emissions shall be stated in compliance with the State of Maine and the EPA, and that the Boiler manufacturer shall provide the following:
 - 1. Carbon Monoxide, CO:
 - 2. Nitrogen Oxide, NOx:
 - 3. Carbon Dioxide, CO2:
 - 4. Particulates:
- C. ASME Compliance: Fabricate and label boilers to comply with 2010 ASME Boiler and Pressure Vessel Code.
- D. ASHRAE/IES 90.1 Compliance: Boilers shall have minimum efficiency according to "Gas Fired Boilers - Minimum Efficiency Requirements."
- E. DOE Compliance: Minimum efficiency of 82% shall comply with 10 CFR 430, Subpart B, Appendix N, and the International Energy Conservation Code, IECC, 2015.

- F. I=B=R Compliance: Boilers shall be tested and rated according to AHRI's "Rating Procedure for Heating Boilers" and "Testing Standard for Commercial Boilers," with I=B=R emblem on a nameplate affixed to boiler.
- G. UL Compliance: Test boilers for compliance with UL 726 and UL 795. Boilers shall be listed and labeled by a testing agency acceptable to authorities having jurisdiction.
- H. CSA Compliance: Test boilers for compliance with CSA B51.
- I. Mounting Frame: Steel rails used to mount assembled boiler package on vibration isolators and anchored to a concrete base.
 - 1. Seismic Fabrication Requirements: Fabricate mounting base and attachment to boiler, accessories, and components with reinforcement strong enough to withstand seismic forces defined in Section 15070 "Vibration and Seismic Controls for HVAC" when mounting base is anchored to building structure.

2.2 MANUFACTURED UNITS

- A. Manufacturers upon approval by required shop drawings:
 - 1. Lochinvar (Basis of design)
 - 2. Cleaver Brooks, Inc.
 - 3. Superior-Triad
 - 4. Fulton
 - 5. RBI, Inc.
 - 6. Approved equal.
- B. Finned Water Tube Boilers Design:
 - 1. Factory fabricated assembled, Finned Tube, and tested boilers with vertical tubes sealed into headers pressure tight and set on a steel base, including ceramic insulation, insulated jacket, flue gas vent, combustion air-intake connections, water supply and return connections, and controls.
 - 2. Finned copper tubing Heat Exchanger, or approved equal with stainless steel baffles
 - 3. Single, or two pass configuration
 - 4. Tubes to be sealed in header
- C. Combustion Chamber: Equipped with ceramic-fiber target wall insulation and flame observation ports, front and back. Forced draft burner
- D. Casing:
 - 1. Jacket: Galvanized sheet, Sheet metal, or stainless steel with snap-in or interlocking closures and powder-coated protective finish.
 - 2. Insulation: Minimum 2-inch- (50-mm-) thick, ceramic-fiber insulation surrounding the heat exchanger rated for up to 2000 deg F.
 - 3. Combustion Chamber Access: Insulated lined, hinged, front.
 - 4. Access: For cleaning between cast-iron sections.

5. Flue connection on top of Boiler shall be constructed of stainless steel containing adjustable outlet damper assembly.
6. Insulated base constructed of aluminized steel to permit boiler to be installed on combustible floor.
7. Control Cabinet: Sheet metal casing shall cover all controls, gas train, and burner.

2.3 FORCED DRAFT GAS BURNER WITH BLOWER:

- A. Provide forced draft burner unit with combustion blower with burner/boiler control panel
- B. Gas Train: Control devices and 5:1 modulation, or low-high-low control sequence shall comply with requirements in with all-inclusive ASME CSD-1, IRI, and UL.
- C. Gas Train: Combination-gas valve with manual shutoff, pressure regulator, and pilot adjustment. Supplied with boiler and have a minimum turndown ratio of 5:1.
- D. Ignition: Intermittent-electric-spark ignition with 100 percent main-valve and pilot-safety shutoff with electronic supervision of burner flame.

2.4 TRIM FOR HOT-WATER BOILERS

- A. Include devices sized to comply with ASME B31.9.
- B. Hot Water supply control with set point. Controllers: Operating, firing rate, and high limit.
- C. The working pressure of the boiler is 50 PSIG.
- D. Safety Relief Valve: ASME rated for 75 PSIG.
- E. Pressure and Temperature Gage: Minimum 3-1/2-inch- (89-mm-) diameter, combination water-pressure and -temperature gage. Gages shall have operating-pressure and -temperature ranges, so normal operating range is about 50 percent of full range.
- F. Boiler Air Vent: Manual/auto as required.
- G. Drain Valve: Minimum NPS 3/4 (DN 20) hose-end gate valve.

2.5 CONTROLS

- A. Refer to Section 15920 "Direct Digital Control (DDC) System for HVAC" and Section 15990. "Sequence of Operations for HVAC."
- B. Boiler operating controls shall include the following devices and features:
 1. Control transformer.
 2. Motorized vent damper.

3. Set-Point Adjust: Set points shall be adjustable.
 4. Low-Water Cutoff and Pump Control:
 5. Boiler primary pump controls to operate (OA temperature at 65 deg F) before boiler operates. Make up air unit, MUA-1 is started and combustion is proof of open operable louvers, then the lead boiler will start after all proofs are received.
 6. Sequence of Operation: Electric, factory-fabricated and field-installed panel to control burner firing rate to maintain HW supply temperature in response to thermostat in HW supply header of the primary HW primary hot water piping circulating the boilers with boiler pumps, BP-1, and BP-2. Refer to Section 15990 Sequence of Operation for additional information.
 - a. Include automatic, alternating-firing sequence for multiple boilers in lead/lag operation to provide equal runtime for boilers.
 - b. Both boilers will operate with Lead/Lag controls down to 40 deg F (adj.). Both boilers will operate below 40 deg F (adj.) as required.
 7. RESET Controls: Sequence of Operation: Electric, factory-fabricated and field-installed panel to control burner firing rate to reset supply-water temperature inversely with outside-air temperature. At 0 deg F (minus 17 deg C) outside-air temperature, set HW supply-water temperature at 200 deg F (93 deg C). At 60 deg F (15 deg C) outside-air temperature, set HW supply-water temperature at 150 deg F (adj). The HWR temperature shall be higher (140 deg F) than the condensing temperature of the boiler exhaust (130- 135 deg F).
- C. Safety Controls: To maintain safe operating conditions, burner safety controls limit burner operation.
1. Low-Water Cutoff Switch: Electronic probe shall prevent burner operation on low water. Cutoff switch shall be automatic-reset type.
 2. Blocked Vent Safety Switch: Manual-reset switch factory mounted on draft diverter.
 3. Rollout Safety Switch: Factory mounted on boiler combustion chamber.
 4. Audible Alarm: Factory mounted on control panel with silence switch; shall sound alarm for above conditions.
 5. Low flow switch: Electronic probe shall prevent burner operation on low flow switch, and shall be automatic-reset type.
- D. Building Management System Interface: Factory install hardware and software to enable building management system to monitor, control, and display boiler status and alarms.
1. Hardwired Points:
 - a. Monitoring: On/off status, common trouble alarm, low-water-level alarm, HW supply and HW return water temperatures for differential control set points.
 - b. Control: On/off operation, hot-water-supply temperature set-point adjustment.

2. A communication interface with building management system shall enable building management system operator to remotely control and monitor the boiler from an operator workstation. Control features available and monitoring points displayed, locally at boiler control panel shall be available through building management system.

2.6 ELECTRICAL POWER

- A. Controllers, Electrical Devices, and Wiring: Electrical devices and connections are specified in electrical Sections.
- B. Single-Point Field Power Connection: Factory-installed and -wired switches, motor controllers, transformers, and other electrical devices necessary shall provide a single-point field power connection to boiler via the Burner Control panel.
 1. House in NEMA 250, Type 1 enclosure.
 2. Wiring shall be numbered and color coded to match wiring diagram.
 3. Install factory wiring outside of an enclosure in a metal raceway.
 4. Field power interface shall be to fused disconnect switch, or circuit breaker.
 5. Provide branch power circuit to each motor and to controls with disconnect switch or circuit breaker.
 6. Provide each motor with overcurrent protection.
 7. Provide emergency shut switch for the boilers, and locate outside of the boiler close to the door leading into the boiler room.

2.7 CAPACITIES AND CHARACTERISTICS

- A. Hot-Water Heating: Refer to capacity data for Boilers on the drawings schedules
- B. Minimum Efficiency AFUE: 82 percent.
- C. Minimum Thermal Efficiency: 80 percent, as per IECC, 2015
- D. Minimum Combustion Efficiency: 100 percent less flue.
- E. Number of Passes: One
- F. The Working pressure is 50 PSIG
- G. Input Rating Method:
 1. I=B=R Output: 720 MBH.
 2. Gross Input: 900 MBH
- H. Output Capacity Refer to the drawings
- I. Blower:

1. Motor Horsepower: 1/6 hp.

J. Electrical Characteristics:

1. Volts: 115 V. 1 phase

2.8 SOURCE QUALITY CONTROL

A. Test and inspect factory-assembled boilers, before shipping, according to 2010 ASME Boiler and Pressure Vessel Code.

B. Burner and Hydrostatic Test: Factory adjust burner to eliminate excess oxygen, carbon dioxide, oxides of nitrogen emissions, and carbon monoxide in flue gas and to achieve combustion efficiency; perform hydrostatic test.

PART 3 - EXECUTION

3.1 BOILER INSTALLATION

A. Equipment Mounting:

1. Install boilers with vibration isolators on cast-in-place concrete equipment base(s). Comply with requirements for equipment bases and foundations specified in Section 03300 "Cast-in-Place Concrete."

2. Comply with requirements for vibration isolation and seismic-restraint devices specified in Section 15070 "Vibration and Seismic Controls for HVAC."

B. Install gas-fired boilers according to International Fuel Gas Code, 2015.

C. Assemble and install boiler trim.

D. Install electrical devices furnished with boiler but not specified to be factory mounted.

E. Install control wiring to field-mounted electrical devices.

3.2 CONNECTIONS

A. Piping installation requirements are specified in Section 15180 "Hydronic Piping." Drawings indicate general arrangement of piping, fittings, and specialties.

B. Install piping adjacent to boiler to allow service and maintenance.

C. Connect gas piping to boiler gas-train inlet with union. Piping shall be at least full size of gas-train connection. Provide a reducer if required.

- D. Connect hot-water piping to supply- and return-boiler connections with shutoff valve and union or flange at each connection.
- E. Install piping from safety relief valves to nearest floor drain.
- F. Install piping from equipment drain connection to nearest floor drain. Piping shall be at least full size of connection. Provide an isolation valve if required.
- G. Connect breeching full size to boiler outlet. Comply with requirements in Section 15860 "Breechings, Boiler Stack and Accessories" for venting materials.

3.3 FIELD QUALITY CONTROL

- A. Perform the following tests and inspections with the assistance of a factory-authorized service representative:
 - 1. Perform installation and startup checks according to manufacturer's written instructions.
 - 2. Leak Test: Hydrostatic test. Repair leaks and retest until no leaks exist.
 - 3. Operational Test: Start units to confirm proper motor rotation and unit operation. Adjust air-fuel ratio and combustion.
 - 4. Test and adjust controls and safeties. Replace damaged and malfunctioning controls and equipment.
 - a. Burner Test: Adjust burner to eliminate excess oxygen, carbon dioxide, oxides of nitrogen emissions, and carbon monoxide in flue gas and to achieve combustion efficiency.
 - b. Check and adjust initial operating set points and high- and low-limit safety set points of fuel supply, water level, and water temperature.
- B. Remove and replace malfunctioning units and retest as specified above.
- C. Boiler will be considered defective if it does not pass tests and inspections.
- D. Prepare test and inspection reports.

3.4 ADJUSTING

- A. Occupancy Adjustments: When requested within 24 months of date of Substantial Completion, provide on-site assistance in adjusting system to suit actual occupied conditions. Provide up to two visits to Project during other-than-normal occupancy hours for this purpose.

3.5 DEMONSTRATION

- A. Train Owner's maintenance personnel to adjust, operate, and maintain boilers.

END OF SECTION

SECTION 15610

FAN COIL UNITS

PART 1 - GENERAL

1.1 SUMMARY

- A. Section includes ductless fan coil units and accessories. Fan coil units are located in the Administration Building basement. FCU-1 has heating and cooling coils. Fan coils, FCU-2, and 3 have only heating coils.

1.2 ACTION SUBMITTALS

- A. Product Data: For each type of product.
- B. Shop Drawings:
 - 1. Include details of equipment assemblies. Indicate dimensions, weights, loads, required clearances, method of field assembly, components, and location and size of each field connection.
 - 2. Include diagrams for power, signal, and control wiring.

1.3 INFORMATIONAL SUBMITTALS

- A. Coordination Drawings: Floor plans, reflected ceiling plans, and other details, drawn to scale and coordinated with each other based on input from installers of the items involved:
- B. Seismic Qualification Certificates: For fan coil units, accessories, and components, from manufacturer.
- C. Field quality-control reports.
- D. Sample warranty.

1.4 CLOSEOUT SUBMITTALS

- A. Operation and maintenance data.

1.5 QUALITY ASSURANCE

- A. Comply with NFPA 70.
- B. ASHRAE Compliance: Applicable requirements in ASHRAE 62.1, Section 5 - "Systems and Equipment" and Section 7 - "Construction and Startup."

- C. ASHRAE/IES 90.1 Compliance: Applicable requirements in ASHRAE/IES 90.1, Section 6 - "Heating, Ventilating, and Air-Conditioning."

PART 2 - PRODUCTS

2.1 SYSTEM DESCRIPTION

- A. Electrical Components, Devices, and Accessories: Listed and labeled as defined in NFPA 70, by a qualified testing agency, and marked for intended location and application.
- B. Factory-packaged and -tested units rated according to AHRI 440, ASHRAE 33, and UL 1995.

2.2 FAN COIL UNITS

- A. Manufacturers upon approval by required shop drawings:
 - 1. Trane (Basis of Design)
 - 2. Carrier
 - 3. Titus
 - 4. Enviro-Tec
 - 5. Johnson Controls
- B. Fan Coil Unit Configurations: Face split.
 - 1. Number of Heating Coils: one with two-pipe system.
 - 2. Number of Cooling Coils, FCU-1 only: 4 -pipe systems, having two-pipe hot water, and two-pipe DX refrigerant piping.
- C. Coil Section Insulation: 1-inch- (25-mm-) thick, coated glass fiber, or foil-covered, closed-cell foam complying with ASTM C 1071 and attached with adhesive complying with ASTM C 916.
 - 1. Surface-Burning Characteristics: Insulation and adhesive shall have a combined maximum flame-spread index of 25 and smoke-developed index of 50 when tested according to ASTM E 84 by a qualified testing agency.
 - 2. Airstream Surfaces: Surfaces in contact with the airstream shall comply with requirements in ASHRAE 62.1.
- D. Main and Auxiliary Drain Pans: Stainless steel. Fabricate pans and drain connections to comply with ASHRAE 62.1.
- E. Chassis: Galvanized steel where exposed to moisture with powder-coat finish and removable access panel. Floor-mounting units shall have leveling screws.

- F. Cabinet: Steel with baked-enamel finish in manufacturer's custom paint color as selected by Architect.
1. Horizontal Unit Bottom Panels: Fastened to unit with cam fasteners, hinged and attached with safety chain; units connected to inlet and supply ductwork systems.
 2. Steel recessing flanges for recessing fan coil units into ceiling or wall.
- G. Filters: Minimum arrestance and a minimum efficiency reporting value (MERV) according to ASHRAE 52.2 and all addendums.
1. MERV Rating: **8** when tested according to ASHRAE 52.2.
 2. Washable Foam: 70 percent arrestance.
- H. Hydronic Coils: Copper tube, with mechanically bonded aluminum fins spaced no closer than 0.1 inch (2.5 mm), rated for a minimum working pressure of 200 psig (1378 kPa) and a maximum entering-water temperature of 220 deg F (104 deg C). Include manual air vent and drain valve.
- I. DX Refrigerant Cooling Coil: Copper tube, with mechanically bonded aluminum fins spaced no closer than 0.1 inch (2.5 mm), rated for a minimum working pressure of 200 psig.
- J. Fan and Motor Board: Removable.
1. Fan: Forward curved, double width, centrifugal; directly connected to motor. Thermoplastic or painted-steel wheels, and aluminum, painted-steel, or galvanized-steel fan scrolls.
 2. Motor: Permanently lubricated, multispeed; resiliently mounted on motor board. Comply with requirements in Section 15000 "Supplemental General Mechanical Requirements."
 3. Wiring Termination: Connect motor to chassis wiring with plug connection.
- K. Factory, Hydronic Piping Package: ASTM B 88, Type L copper tube with wrought-copper fittings and brazed joints. Label piping to indicate service, inlet, and outlet.
1. Two-way, two-position control valve for hot water heating coil.
 2. Hose Kits: Minimum 400-psig (2758-kPa) working pressure and operating temperatures from 33 to 211 deg F (0.5 to 99 deg C). Tag hose kits to equipment designations.
 - a. Length: 24 inches (600 mm).
 - b. Minimum Diameter: Equal to fan coil unit connection size.
 3. Refer to valves for hook ups in spec section 15185, Hydronic piping specialties.
 4. Two-Piece Ball Valves: Bronze body with full-port, chrome-plated bronze ball; PTFE or TFE seats; and 600-psig (4140-kPa) minimum CWP rating and blowout-proof stem.

5. Calibrated-Orifice Balancing Valves: Bronze body, ball type; 125-psig (860-kPa) working pressure, 250 deg F (121 deg C) maximum operating temperature; with calibrated orifice or venturi, connections for portable differential pressure meter with integral seals, threaded ends, and a memory stop to retain set position.
 6. Automatic Flow-Control Valve: Brass or ferrous-metal body; 300-psig (2070-kPa) working pressure at 250 deg F (121 deg C); with removable, corrosion-resistant, tamperproof, self-cleaning piston spring; factory set to maintain constant indicated flow with plus or minus 10 percent over differential pressure range of 2 to 80 psig (13.8 to 552 kPa).
 7. Y-Pattern Hydronic Strainers: Cast-iron body (ASTM A 126, Class B); 125-psig (860-kPa) working pressure; with threaded connections, bolted cover, perforated stainless-steel basket, and bottom drain connection. Include minimum NPS 1/2 (DN 15) hose-end, full-port, ball-type blowdown valve in drain connection.
 8. Wrought-Copper Unions: ASME B16.22.
 9. Risers: ASTM B 88, Type L (ASTM B 88M, Type copper pipe with hose and ball valve for system flushing).
- L. Control devices and operational sequences are specified in Section 15920 "Direct Digital Control (DDC) System for HVAC", and Section 15990 "Sequence of Operations for HVAC DDC."
- M. Basic Unit Controls:
1. Control voltage transformer.
 2. Wall-mounting thermostat with the following features:
 - a. Heat-cool-off switch.
 - b. Fan on-auto switch.
 - c. Fan-speed switch.
 - d. Adjustable deadband.
 - e. Concealed set point.
 - f. Exposed indication.
 - g. Degree F indication.
 3. Unoccupied-period-override push button.
 4. Data entry and access port.
 - a. Input data includes room temperature, and humidity set points and occupied and unoccupied periods.
 - b. Output data includes room temperature and humidity, supply-air temperature, entering-water temperature, operating mode, and status.
- N. Local Terminal Controller:
1. Scheduled Operation: Occupied and unoccupied periods on seven-day clock with a minimum of four programmable periods per day.
 2. Unit Supply-Air Fan Operation:

- a. Occupied Periods: Fan runs continuously.
3. Cooling-Coil Operation:
 - a. Occupied Periods: FCU-1 to run continuously.
 - b. FCU-1: local controls shall maintain room cooling temperature setpoint.
4. Heating-Coil Operation:
 - a. Occupied Periods: Open control valve, 2-position to provide heating if room temperature falls below thermostat set point, and to maintain room setpoint.
5. Monitor room Temperature setpoint and actual temperature for fan coil units, FCU-1, FCU-2 and FCU-3. Provide signals to DDC system for remote monitoring of the MTA storage room, as served by FCU-1.
6. Controller shall have volatile-memory backup.
- O. Electrical Connection: Factory wire motors and controls for a single electrical connection.
- P. Capacities and Characteristics: Refer to the drawings.

PART 3 - EXECUTION

3.1 INSTALLATION

- A. Install fan coil units level and plumb.
- B. Install fan coil units to comply with NFPA 90A.
- C. Connect FCU-1 with two (2) refrigerant lines to remote condensing unit located outside.
- D. Suspend fan coil units from structure with elastomeric hangers. Vibration isolators are specified in Section 15070 "Vibration and Seismic Controls for HVAC Piping and Equipment."
- E. Verify locations of thermostats, and other exposed control sensors with Drawings and room details before installation. Install devices 48 inches (1220 mm) above finished floor.
- F. Install new filters in each fan coil unit within two weeks after Substantial Completion.

- G. Piping installation requirements are specified in other Sections. Drawings indicate general arrangement of piping, fittings, and specialties. Specific connection requirements are as follows:
1. Install piping adjacent to machine to allow service and maintenance.
 2. Connect piping to fan coil unit factory hydronic piping package. Install piping package if shipped loose.
 3. Provide ball valves as noted in spec section 15110, balancing valves in spec section 18185, Hydronic Specialties.
 4. Connect condensate drain to indirect waste.
 - a. Install condensate trap of adequate depth to seal against fan pressure. Install cleanouts in piping at changes of direction.
- H. Ground equipment according to Section 16450", Grounding and Bonding for Electrical Systems."
- I. Connect wiring according to Section 16120", Low-Voltage Electrical Power Conductors and Cables."

3.2 FIELD QUALITY CONTROL

- A. Perform the following tests and inspections with the assistance of a factory-authorized service representative:
1. Operational Test: After electrical circuitry has been energized, start units to confirm proper motor rotation and unit operation.
 2. Operate electric heating elements through each stage to verify proper operation and electrical connections.
 3. Test and adjust controls and safety devices. Replace damaged and malfunctioning controls and equipment.
- B. Remove and replace malfunctioning units and retest as specified above.
- C. Prepare test and inspection reports.

3.3 ADJUSTING

- A. Adjust initial temperature and humidity set points.
- B. Occupancy Adjustments: When requested within 12 months of date of Substantial Completion, provide on-site assistance in adjusting system to suit actual occupied conditions. Provide up to two visits to Project during other-than-normal occupancy hours for this purpose.

END OF SECTION

SECTION 15620

PROPELLER UNIT HEATERS

PART 1 – GENERAL

1.1 SUMMARY

A. Section includes propeller unit heaters with hot-water coils.

1.2 ACTION SUBMITTALS

A. Product Data: For each type of product.

1. Include rated capacities, operating characteristics, furnished specialties, and accessories.

B. Shop Drawings:

1. Include plans, elevations, sections, and details.
2. Include details of equipment assemblies. Indicate dimensions, weights, loads, required clearances, method of field assembly, components, and location and size of each field connection.
3. Include location and size of each field connection.
4. Include details of anchorages and attachments to structure and to supported equipment.
5. Include equipment schedules to indicate rated capacities, operating characteristics, furnished specialties, and accessories.
6. Indicate location and arrangement of piping valves and specialties.
7. Indicate location and arrangement of integral controls.
8. Wiring Diagrams: Power, signal, and control wiring.

1.3 INFORMATIONAL SUBMITTALS

A. Coordination Drawings: Floor plans, reflected ceiling plans, and other details, drawn to scale, on which the following items are shown and coordinated with each other, using input from installers of the items involved:

1. Suspended ceiling components.
2. Structural members to which propeller unit heaters will be attached.
3. Method of attaching hangers to building structure.
4. Size and location of initial access modules for acoustical tile.

B. Seismic Qualification Certificates: Submit certification that propeller unit heaters, accessories, and components will withstand seismic forces defined in Section 15070 "Vibration and Seismic Controls for HVAC."

C. Field quality-control reports.

1.4 CLOSEOUT SUBMITTALS

A. Operation and maintenance data.

PART 2 - PRODUCTS

2.1 MANUFACTURERS

A. Provide one of the following manufacturers upon approval by require shop drawings:

1. Modine (Basis of Design)
2. Trane
3. Carrier
4. Vulcan

2.2 DESCRIPTION

- A. Assembly including casing, coil, fan, and motor in [**vertical**] [**and**] [**horizontal**] discharge configuration with adjustable discharge louvers.
- B. Electrical Components, Devices, and Accessories: Listed and labeled as defined in NFPA 70, by a qualified testing agency, and marked for intended location and application.

2.3 PERFORMANCE REQUIREMENTS

- A. ASHRAE Compliance: Applicable requirements in ASHRAE 62.1, Section 5 - "Systems and Equipment" and Section 7 - "Construction and Startup."
- B. ASHRAE/IESNA 90.1 Compliance: Applicable requirements in ASHRAE/IESNA 90.1, Section 6 - "Heating, Ventilating, and Air-Conditioning."
- C. Seismic Performance: Propeller unit heaters shall withstand the effects of earthquake motions determined according to ASCE/SEI 7.
1. The term "withstand" means "the unit will remain in place without separation of any parts when subjected to the seismic forces specified"

2.4 HOUSINGS

- A. Finish: Manufacturer's standard baked enamel applied to factory-assembled and - tested propeller unit heaters before shipping.
- B. Airstream Surfaces: Surfaces in contact with the airstream shall comply with requirements in ASHRAE 62.1.

- C. Discharge Louver: Adjustable fin diffuser for horizontal units and conical diffuser for vertical units.

2.5 COILS

- A. General Coil Requirements: Test and rate hot-water propeller unit-heater coils according to ASHRAE 33.
- B. Hot-Water Coil: Copper tube, minimum 0.025-inch (0.635-mm) wall thickness, with mechanically bonded aluminum fins spaced no closer than 0.1 inch (2.5 mm) and rated for a minimum working pressure of 200 psig (1380 kPa) and a maximum entering-water temperature of 325 deg F (163 deg C), with manual air vent. Test for leaks to 350 psig (2413 kPa) underwater.

2.6 FAN AND MOTOR

- A. Fan: Propeller type with aluminum wheel directly mounted on motor shaft in the fan venturi.
- B. Motor: Permanently lubricated, multispeed. Comply with requirements in Section 15000 "Supplemental General Mechanical Requirements."

2.7 CONTROLS

- A. Control Devices:
 - 1. Unit-mounted, fan-speed switch.
 - 2. Wall-mounted thermostat for unit heaters, UH-1/2.
 - 3. Unit-mounted thermostat for UH-3 through in the tunnel.

2.8 CAPACITIES AND CHARACTERISTICS

- A. Heating Capacity: Refer to the drawings

PART 3 - EXECUTION

3.1 EXAMINATION

- A. Examine areas to receive propeller unit heaters for compliance with requirements for installation tolerances and other conditions affecting performance of the Work.
- B. Examine roughing-in for piping and electrical connections to verify actual locations before unit-heater installation.
- C. Proceed with installation only after unsatisfactory conditions have been corrected.

3.2 INSTALLATION

- A. Install propeller unit heaters to comply with NFPA 90A.
- B. Install propeller unit heaters level and plumb.
- C. Provide unit heaters in tunnel to comply with maximum unit heater width restrictions, and walkway, and as noted on the schedules.
- D. Suspend propeller unit heaters from structure with all-thread hanger rods and elastomeric hangers, or spring hangers. Hanger rods and attachments to structure are specified in Section 15071 "Hangers and Supports for HVAC Piping and Equipment." Vibration hangers are specified in Section 15070 "Vibration and Seismic Controls for HVAC."
- E. Install wall-mounted thermostats and switch controls in electrical outlet boxes at heights to match lighting controls. Verify location of thermostats and other exposed control sensors with Drawings and room details before installation.

3.3 CONNECTIONS

- A. Piping installation requirements are specified in Section 15180 "Hydronic Piping" and Section 15185 "Hydronic Piping Specialties." Drawings indicate general arrangement of piping, fittings, and specialties.
- B. Install piping adjacent to unit heater to allow service and maintenance. Allow space for walkway in the tunnel. Install piping to UH-3 through 12 in the tunnel to comply with the space restrictions allowed for the piping and means of maintenance.
- C. Connect piping to propeller unit heater's factory, hot-water piping package. Install the piping package if shipped loose.
- D. Comply with safety requirements in UL 1995.
- E. Unless otherwise indicated, install union and gate or ball valve on supply-water connection and union and calibrated balancing valve on return-water connection of propeller unit heater. Hydronic specialties are specified in Section 15185 "Hydronic Piping Specialties."
- F. Ground equipment according to Section 16450 "Grounding and Bonding for Electrical Systems."
- G. Connect wiring according to Section 16120 "Low-Voltage Electrical Power Conductors and Cables."

3.4 FIELD QUALITY CONTROL

- A. Perform the following tests and inspections with the assistance of a factory-authorized service representative:

1. Operational Test: After electrical circuitry has been energized, start units to confirm proper motor rotation and unit operation.
 2. Test and adjust controls and safety devices. Replace damaged and malfunctioning controls and equipment.
- B. Units will be considered defective if they do not pass tests and inspections.
- C. Prepare test and inspection reports.

END OF SECTION

SECTION 15630

CABINET UNIT HEATERS

PART 1 - GENERAL

1.1 SUMMARY

- A. Section includes cabinet unit heaters with centrifugal fans and hot-water coils. Cabinet unit heaters are located in the Toll booths, and the Administration Building 1st floor at the doors.

1.2 ACTION SUBMITTALS

- A. Product Data: For each type of product.
 - 1. Include rated capacities, operating characteristics, furnished specialties, and accessories.
- B. Shop Drawings:
 - 1. Include plans, elevations, sections, and details.
 - 2. Include details of equipment assemblies. Indicate dimensions, weights, loads, required clearances, method of field assembly, components, and location and size of each field connection.
 - 3. Include location and size of each field connection.
 - 4. Include details of anchorages and attachments to structure and to supported equipment.
 - 5. Include equipment schedules to indicate rated capacities, operating characteristics, furnished specialties, and accessories.
 - 6. Indicate location and arrangement of piping valves and specialties.
 - 7. Indicate location and arrangement of integral controls.
 - 8. Wiring Diagrams: Power, signal, and control wiring.
- C. Samples: For each exposed product and for each color and texture specified.

1.3 INFORMATIONAL SUBMITTALS

- A. Coordination Drawings: Floor plans, reflected ceiling plans, and other details, drawn to scale, on which the following items are shown and coordinated with each other, using input from installers of the items involved:
 - 1. Suspended ceiling components.
 - 2. Structural members to which cabinet unit heaters will be attached.
 - 3. Method of attaching hangers to building structure.
 - 4. Size and location of initial access modules for acoustical tile.

5. Items penetrating finished ceiling, in the Administration Building including the following:
 - a. Lighting fixtures.
 - b. Air outlets and inlets.
 - c. Speakers.
 - d. Sprinklers.
 - e. Access panels.
 6. Perimeter moldings for exposed or partially exposed cabinets.
- B. Seismic Qualification Certificates: Submit certification that cabinet unit heaters, accessories, and components will withstand seismic forces defined in Section 15070 "Vibration and Seismic Controls for HVAC."
- C. Field quality-control reports.

1.4 CLOSEOUT SUBMITTALS

- A. Operation and maintenance data.

PART 2 - PRODUCTS

2.1 MANUFACTURERS

1. Provide any one of the manufacturers upon approval by required shop drawings:
 - a. Modine (Basis of Design)
 - b. Trane
 - c. Carrier
 - d. Vulcan

2.2 DESCRIPTION

- A. Factory-assembled and -tested unit complying with AHRI 440.
- B. Electrical Components, Devices, and Accessories: Listed and labeled as defined in NFPA 70, by a qualified testing agency, and marked for intended location and application.

2.3 PERFORMANCE REQUIREMENTS

- A. ASHRAE Compliance: Applicable requirements in ASHRAE 62.1, Section 5 - "Systems and Equipment" and Section 7 - "Construction and Startup."

- B. ASHRAE/IESNA 90.1 Compliance: Applicable requirements in ASHRAE/IESNA 90.1, Section 6 - "Heating, Ventilating, and Air-Conditioning."
- C. Seismic Performance: Cabinet unit heaters shall withstand the effects of earthquake motions determined according to ASCE/SEI 7.
 - 1. The term "withstand" means "the unit will remain in place without separation of any parts when subjected to the seismic forces specified."

2.4 COIL SECTION INSULATION

- A. Insulation Materials: Comply with NFPA 90A or NFPA 90B. Unicellular polyethylene thermal plastic, preformed sheet insulation complying with ASTM C 534, Type II, except for density.
 - 1. Thickness: 3/4 inch (19 mm)
 - 2. Thermal Conductivity (k-Value): 0.24 Btu x in./h x sq. ft. at 75 deg F (0.034 W/m x K at 24 deg C) mean temperature.
 - 3. Fire-Hazard Classification: Maximum flame-spread index of 25 and smoke-developed index of 50 when tested according to ASTM C 411.
 - 4. Adhesive: As recommended by insulation manufacturer and complying with NFPA 90A or NFPA 90B.
 - 5. Airstream Surfaces: Surfaces in contact with the airstream shall comply with requirements in ASHRAE 62.1.

2.5 CABINETS

- A. Material: Steel with baked-enamel finish with manufacturer's custom paint, in color selected by Architect].
 - 1. Vertical Unit, Exposed Front Panels: Minimum 0.0677-inch- (1.7-mm-) thick galvanized sheet steel, removable panels with channel-formed edges secured with tamperproof cam fasteners.
 - 2. Horizontal Unit, Exposed Bottom Panels: Minimum 0.0677-inch- (1.7-mm-) thick galvanized sheet steel, removable panels secured with tamperproof cam fasteners and safety chain.
 - 3. Recessed Flanges: Steel, finished to match cabinet.
 - 4. Control Access Door: Key operated.
 - 5. Base: Minimum 0.0528-inch- (1.35-mm-) thick steel, finished to match cabinet, 4 inches high with leveling bolts.
 - 6. Extended Piping Compartment: minimum 8-inch- (200-mm-) wide piping end pocket.
 - 7. False Back: Minimum 0.0428-inch- (1.1-mm-) thick steel, finished to match cabinet.
 - 8. Outdoor-Air Wall Box; Not Used

2.6 FILTERS

- A. Minimum Arrestance: According to ASHRAE 52.1 and a minimum efficiency reporting value (MERV) according to ASHRAE 52.2.
1. Glass Fiber Treated with Adhesive: 80 percent arrestance and MERV 5.
 2. Pleated: 90 percent arrestance and MERV 7.

2.7 COILS

- A. Hot-Water Coil: Copper tube, with mechanically bonded aluminum fins spaced no closer than 0.1 inch (2.5 mm) and rated for a minimum working pressure of 200 psig (1378 kPa) and a maximum entering-water temperature of 220 deg F (104 deg C). Include manual air vent and drain.

2.8 CONTROLS

- A. Fan and Motor Board: Removable.
1. Fan: Forward curved, double width, centrifugal, directly connected to motor; thermoplastic or painted-steel wheels and aluminum, painted-steel, or galvanized-steel fan scrolls.
 2. Motor: Permanently lubricated, multispeed; resiliently mounted on motor board. Comply with requirements in Section 15700 "Common Motor Requirements for HVAC Equipment."
 3. Wiring Terminations: Connect motor to chassis wiring with plug connection.
- B. Factory, Hot-Water Piping Package: ASTM B 88, Type L (ASTM B 88M, Type B) copper tube with wrought-copper fittings and brazed joints. Label piping to indicate service, inlet, and outlet.
1. Two-way, modulating control valves for all CUH's, except one CUH. Two-way control valve for the CUH-1, 2, 3 in the Administration Building
 2. The CUH units in the Toll Booths, CUH-4 through 12 will not have control valves in the return piping for temperature. The units will be water balanced with balancing valves, set for all operations. Heating control will be via the manual fan speed controls.
 3. Hose Kits: Minimum 400-psig (2758-kPa) working pressure, and operating temperatures from 33 to 211 deg F (0.5 to 99 deg C). Tag hose kits to equipment designations.
 - a. Length: 24 inches (600 mm).
 - b. Minimum Diameter: Equal to cabinet unit-heater connection size.

4. Two-Piece, Ball Valves: Bronze body with full-port, chrome-plated bronze ball; PTFE or TFE seats; and 600-psig (4140-kPa) minimum CWP rating and blowout-proof stem.
 5. Calibrated-Orifice Balancing Valves: Bronze body, ball type, 125-psig (860-kPa) working pressure, 250 deg F (121 deg C) maximum operating temperature; with calibrated orifice or venture, connection for portable differential pressure meter with integral seals, threaded ends, and equipped with a memory stop to retain set position.
 6. Y-Pattern, Hot-Water Strainers: Cast-iron body (ASTM A 126, Class B); 125-psig (860-kPa) minimum working pressure; with threaded connections, bolted cover, perforated stainless-steel basket, and bottom drain connection. Include minimum NPS 1/2 (DN 15) threaded pipe and full-port ball valve in strainer drain connection.
 7. Wrought-Copper Unions: ASME B16.22.
- C. Control devices and operational sequences are specified in Section 2 "Direct Digital Control (DDC) System for HVAC" and Section 15990 "Sequence of Operations for HVAC DDC."
- D. Basic Unit Controls:
1. Control voltage transformer.
 2. Wall-mounted thermostat with the following features:
 - a. Heat-off switch.
 - b. Fan on-auto switch.
 - c. Manual fan-speed switch (3-speeds).
 - d. Adjustable deadband.
 - e. Concealed set point.
 - f. Exposed indication.
 - g. Deg F indication.
 3. Unoccupied period override push button.
 4. Data entry and access port.
 - a. Input data includes room temperature and occupied and unoccupied periods.
 - b. Output data includes room temperature, supply-air temperature, entering-water temperature, operating mode, and status.
- E. DDC Terminal Controller:
1. Scheduled Operation-CUH's in Administration Building: Occupied and unoccupied periods on seven-day clock with a minimum of four programmable periods per day.
 2. Scheduled Operation in Toll Booths: Occupied and unoccupied periods based on Toll Booth Operator pressing a Push Button when entering (Occupied) and

leaving (Unoccupied) the booth. 3-Speed fan controls will be available for occupants.

3. Toll Booths Temperature Monitoring: A temperature sensor will be located in each toll booth to monitor the temperature inside the Toll Booth space and the output sent to the BMS panel in the Administration Building.
 4. Unit Supply-Air Fan Operations - Administration Building:
 - a. Occupied Periods: Fan runs continuously.
 - b. Unoccupied Periods: Fan cycles to maintain setback room temperature.
 5. Heating-Coil Operations- Administration Building:
 - a. Occupied Periods: Modulate control valve to provide heating if room temperature falls below thermostat set point.
 - b. Unoccupied Periods: Start fan and open control valve if room temperature falls below setback temperature.
 6. Controller shall have volatile-memory backup.
- F. Interface with DDC System for HVAC Requirements:
1. Interface relay for scheduled operation.
 2. Interface relay to provide indication of fault at central workstation.
 3. Interface shall be BAC-net, or LonWorks compatible for central DDC system for HVAC workstation and include the following functions:
 - a. Adjust set points.
 - b. Cabinet unit-heater start, stop, and operating status.
 - c. Occupied and unoccupied schedules.
- G. Electrical Connection: Factory-wired motors and controls for a single field connection.

2.9 CAPACITIES AND CHARACTERISTICS: Refer to the Drawings for CUH capacity Requirements:

A. Cabinet:

1. Vertical, Floor-Mounted- CUH'S 4-12 in Toll Booths: Upflow.
 - a. Air Inlet: Open bottom, or front bottom louver.
 - b. Air Outlet: Top Front, punched louver
2. Horizontal, Fully Recessed - Administration Building, Ceiling Mounted, CUH'S 1-3:
 - a. Air Inlet: Upflow, Front, punched louver.
 - b. Air Outlet: Downflow, rear, punched louver

- B. Electrical Characteristics for Single-Point Connection: Refer to the drawings

PART 3 - EXECUTION

3.1 EXAMINATION

- A. Examine areas to receive cabinet unit heaters for compliance with requirements for installation tolerances and other conditions affecting performance of the Work.
- B. Examine roughing-in for piping and electrical connections to verify actual locations before unit-heater installation.
- C. Proceed with installation only after unsatisfactory conditions have been corrected.

3.2 INSTALLATION

- A. Install wall boxes in finished wall assembly; seal and weatherproof. Joint-sealant materials and applications are specified in Section 07900 "Joint Sealants."
- B. Install cabinet unit heaters to comply with NFPA 90A.
- C. Suspend cabinet unit heaters (CUH-1/2/3) in the Administration Building from structure with elastomeric hangers. Vibration isolators are specified in Section 15070 "Vibration and Seismic Controls for HVAC."
- D. Install floor mounted CUH-4 through 12 in the Toll Booths under the counter. Unit shall be configured to include top horizontal discharge for supply air, and bottom return air inlet. Coordinate the selected CUH height for under counter height. Fan speed is the only occupant means of control during the winter.
- E. Install wall-mounted thermostats for CUH-1/2/3, and switch controls in electrical outlet boxes at heights to match lighting controls. Verify location of thermostats and other exposed control sensors with Drawings and room details before installation.
- F. Install new filters in each fan-coil unit within two weeks of Substantial Completion.
- G. Install Temperature sensors inside the Toll booths for monitoring of the inside temperature and the signal sent to the BMS for remote monitoring.

3.3 CONNECTIONS

- A. Piping installation requirements are specified in Section 15180 "Hydronic Piping," Section 15185 Hydronic Piping Specialties." Drawings indicate general arrangement of piping, fittings, and specialties.
- B. Install piping adjacent to cabinet unit heater to allow service and maintenance.

- C. Connect piping to cabinet unit heater's factory, hot-water piping package. Install the piping package if shipped loose.
- D. Comply with safety requirements in UL 1995.
- E. Unless otherwise indicated, install union and gate or ball valve on supply-water connection and union and calibrated balancing valve on return-water connection of cabinet unit heater. Hydronic specialties are specified in Section 15180 "Hydronic Piping" and Section 15185 Hydronic Piping Specialties."
- F. CUH-1/2/3: provide temperature controls with unit mounted thermostat for space temperature controls. Fan speed can be adjusted.
- G. CUH-4 through 12: The CUH's will not have space temperature control as with CUH-1/2/3. The return water will be balanced and set for rated flow with balancing valve. Fan speeds (speeds) will be available for occupant adjustment for heating control.
- H. Ground equipment according to Section 16450 "Grounding and Bonding for Electrical Systems."
- I. Connect wiring according to Section 16120 "Low-Voltage Electrical Power Conductors and Cables."

3.4 FIELD QUALITY CONTROL

- A. Perform the following tests and inspections with the assistance of a factory-authorized service representative:
 - 1. Operational Test: After electrical circuitry has been energized, start units to confirm proper motor rotation and unit operation.
 - 2. Test and adjust controls and safety devices. Replace damaged and malfunctioning controls and equipment.
- B. Units will be considered defective if they do not pass tests and inspections.
- C. Prepare test and inspection reports.

END OF SECTION

SECTION 15640

BASEBOARD RADIATION HEATERS

PART 1 - GENERAL

1.1 SUMMARY

- A. Section includes hydronic baseboard radiation heaters.

1.2 ACTION SUBMITTALS

- A. Product Data: For each type of product.

1. Include rated capacities, operating characteristics, furnished specialties, and accessories.

- B. Shop Drawings:

1. Include plans, elevations, sections, and details.
2. Include details of equipment assemblies. Indicate dimensions, weights, loads, required clearances, method of field assembly, components, and location and size of each field connection.
3. Include details and dimensions of custom-fabricated enclosures.
4. Indicate location and size of each field connection.
5. Indicate location and arrangement of piping valves and specialties.
6. Indicate location and arrangement of integral controls.
7. Include enclosure joints, corner pieces, access doors, and other accessories.
8. Include diagrams for power, signal, and control wiring.

- C. Samples: For each exposed product and for each color and texture specified.

1.3 Closeout Submittals:

1. Operations and Maintenance Manuals.

1.4 INFORMATIONAL SUBMITTALS

- A. Field quality-control reports.

PART 2 - PRODUCTS

2.1 HOT-WATER BASEBOARD RADIATION HEATERS

- A. Manufacturers:

1. Provide any one of the manufacturers upon approval by required shop drawings:

- a. Modine (basis of design)
 - b. Trane
 - c. Carrier
 - d. Vulcan
 - e. Approved Equal
- B. Performance Ratings: Rate baseboard radiation heaters according to Hydronics Institute's "I=B=R Testing and Rating Standard for Baseboard Radiation."
- C. Heating Elements: Copper tubing mechanically expanded into flanged collars of evenly spaced aluminum fins resting on polypropylene element glides. One end of tube shall be belled.
- 1. Tube Diameter: NPS 3/4 (DN 20), or NPS 1 (DN 25), as required.
 - 2. Fin Size: 2-1/2 by 2-1/2 inches (63 by 63 mm), or 3 by 3 inches (76 by 76 mm).
 - 3. Fin Spacing: 40 per foot (131 per m).
 - 4. Number of Tiers: 1.
 - 5. Heat Output: See Drawings.
 - 6. Entering-Air Temperature: 70 deg F.
 - 7. Average Water Temperature: 170 deg F
 - 8. Minimum Water Velocity: 1/2 fps (0.15 m/s).
- D. Rust-Resistant Enclosures: Minimum 0.052-inch- (1.3-mm-) thick ASTM A 653/A 653M, G60 (Z180) galvanized-steel, removable front cover.
- 1. Full-height back.
 - 2. End panel.
 - 3. End caps.
 - 4. Inside and outside corners.
 - 5. Valve access door.
 - 6. Joiner pieces to snap together.
 - 7. Enclosure Height:
 - 8. Enclosure Depth:
 - 9. Finish: Baked-enamel finish in manufacturer's standard color as selected by Architect.
 - 10. Element Brackets: Primed and painted steel to support front panel and element.

PART 3 - EXECUTION

3.1 BASEBOARD RADIATION HEATER INSTALLATION

- A. Install units level and plumb.
- B. Install enclosure continuously around corners, using outside and inside corner fittings.
- C. Join sections with splice plates and filler pieces to provide continuous enclosure.
- D. Install access doors for access to valves.

- E. Install enclosure continuously from wall to wall.
- F. Terminate enclosures with manufacturer's end caps except where enclosures are indicated to extend to adjoining walls.
- G. Install isolation ball valves within reach of access door provided in enclosure.
- H. Install air-seal gasket between wall and recessed flanges or front cover of fully recessed unit.
- I. Install piping within pedestals for freestanding units.

3.2 CONNECTIONS

- A. Piping installation requirements are specified in Section 15180 "Hydronic Piping" and Section 15185 "Hydronic Piping Specialties". Drawings indicate general arrangement of piping, fittings, and specialties.
- B. Connect hot-water baseboard radiation heaters and components to piping according to Section 15180 "Hydronic Piping" and Section 15185 "Hydronic Piping Specialists".
 - 1. Install shutoff valves on inlet and outlet, and balancing valve on outlet.
- C. Install 2-way control valves for multiple BBH for each room as noted on the drawings. Locate control valves and valve assemblies in HW return piping in the basement near the risers. The control valves shall be interconnected with local control panels and room thermostats.
- D. Install piping adjacent to baseboard radiation heaters to allow service and maintenance.

3.3 FIELD QUALITY CONTROL

- A. Perform the following field tests and inspections:
 - 1. Leak Test: After installation, charge system and test for leaks. Repair leaks and retest until no leaks exist.
 - 2. Operational Test: After electrical circuitry has been energized, start units to confirm proper operation.
 - 3. Test and adjust controls and safeties. Replace damaged and malfunctioning controls and equipment.
- B. Units will be considered defective if they do not pass tests and inspections.
- C. Prepare test and inspection reports.

END OF SECTION

SECTION 15700

COMMON MOTOR REQUIREMENTS FOR HVAC EQUIPMENT

PART 1 – GENERAL

1.1 SUMMARY

- A. Section includes general requirements for single-phase and poly-phase, general-purpose, horizontal, small and medium, squirrel-cage induction motors for use on ac power systems up to 600 V and installed at equipment manufacturer's factory or shipped separately by equipment manufacturer for field installation.

1.2 COORDINATION

- A. Coordinate features of motors, installed units, and accessory devices to be compatible with the following:
 - 1. Motor controllers.
 - 2. Variable Frequency Drives, VFD'S
 - 3. Torque, speed, and horsepower requirements of the load.
 - 4. Ratings and characteristics of supply circuit and required control sequence.
 - 5. Ambient and environmental conditions of installation location.

PART 2 - PRODUCTS

2.1 GENERAL MOTOR REQUIREMENTS

- A. Comply with NEMA MG 1 unless otherwise indicated.

2.2 MOTOR CHARACTERISTICS

- A. Duty: Continuous duty at ambient temperature of 40 deg C (104°F), and at altitude of 3300 feet above sea level.
- B. Capacity and Torque Characteristics: Sufficient to start, accelerate, and operate connected loads at designated speeds, at installed altitude and environment, with indicated operating sequence, and without exceeding nameplate ratings or considering service factor.

2.3 POLYPHASE MOTORS

- A. Description: NEMA MG 1, Design B, medium induction motor.

- B. Efficiency: Energy efficient, as defined in NEMA MG 1.
- C. Service Factor: Minimum, 1.15.
- D. Multispeed Motors: Variable torque.
 - 1. For motors with 2:1 speed ratio, consequent pole, single winding.
 - 2. For motors with other than 2:1 speed ratio, separate winding for each speed.
- E. Rotor: Random-wound, squirrel cage.
- F. Bearings: Regreasable, shielded, antifriction ball bearings suitable for radial and thrust loading.
- G. Temperature Rise: Match insulation rating.
- H. Insulation: Class F.
- I. Code Letter Designation:
 - 1. Motors 15 HP and Larger: NEMA starting Code F or Code G.
 - 2. Motors Smaller than 15 HP: Manufacturer's standard starting characteristic.
- J. Enclosure Material: Cast iron for motor frame sizes 324T and larger; rolled steel for motor frame sizes smaller than 324T.

2.4 POLYPHASE MOTORS WITH ADDITIONAL REQUIREMENTS

- A. Motors Used with Reduced-Voltage and Multispeed Controllers: Match wiring connection requirements for controller with required motor leads. Provide terminals in motor terminal box, suited to control method.
- B. Motors Used with Variable Frequency Controllers: Ratings, characteristics, and features coordinated with and approved by controller manufacturer.
 - 1. Windings: Copper magnet wire with moisture-resistant insulation varnish, designed and tested to resist transient spikes, high frequencies, and short time rise pulses produced by pulse-width modulated inverters.
 - 2. Energy- and Premium-Efficient Motors: Class B temperature rise; Class F insulation.
 - 3. Inverter-Duty Motors: Class F temperature rise; Class H insulation.
 - 4. Thermal Protection: Comply with NEMA MG 1 requirements for thermally protected motors.
 - 5. Voltages for 3-phase motors will require either 460 V-3 phase, or 208 V- 3 phase power.
- C. Motor HP:
 - 1. Motors $\frac{1}{2}$ hp and less shall be single-phase, 120V.
 - 2. Motors $\frac{3}{4}$ and more shall be 460V-3phase, or 208V-3 phase.

2.5 SINGLE-PHASE MOTORS

- A. Motors larger than 1/2 hp shall be one of the following, to suit starting torque and requirements of specific motor application:
 - 1. Permanent-split capacitor.
 - 2. Split phase.
 - 3. Capacitor start, inductor run.
 - 4. Capacitor start, capacitor run.
- B. Multispeed Motors: Variable-torque, permanent-split-capacitor type.
- C. Bearings: Prelubricated, antifriction ball bearings or sleeve bearings suitable for radial and thrust loading.
- D. Motors 1/2 HP and Smaller: Shaded-pole type.
- E. Thermal Protection: Internal protection to automatically open power supply circuit to motor when winding temperature exceeds a safe value calibrated to temperature rating of motor insulation. Thermal-protection device shall automatically reset when motor temperature returns to normal range.
- F. Voltages for single phase motors shall be 120-V power.

PART 3 - EXECUTION (Not Applicable)

END OF SECTION

SECTION 15720

MODULAR INDOOR CENTRAL-STATION AIR-HANDLING UNITS

PART 1 - GENERAL

1.1 RELATED DOCUMENTS

- A. Drawings and general provisions of the Contract, including General and Supplementary Conditions and Division 01 Specification Sections, apply to this Section.

1.2 SUMMARY

- A. Section Includes:
 - 1. Variable -air-volume, interior, multi-zone air-handling unit, AHU-1: Administration Building, 1st floor rooms including Heating Ventilation and Air Conditioning.
 - 2. Constant-air-volume, interior, single-zone air-handling unit, AHU-2: Tunnel including Heating and Ventilating system
 - 3. Make-Up Air unit, MUA-1 for providing heating of combustion and ventilation outside air for the Boilers, and Boiler room.

1.3 PERFORMANCE REQUIREMENTS

- A. Delegated Design: Design vibration isolation and seismic-restraint details, including comprehensive engineering analysis by a qualified professional engineer, using performance requirements and design criteria indicated.
- B. Structural Performance: Casing panels shall be self-supporting and capable of withstanding 133 percent of internal static pressures indicated, without panel joints exceeding a deflection of $L/200$ where "L" is the unsupported span length within completed casings.
- C. Seismic Performance: Air-handling units shall withstand the effects of earthquake motions determined according to ASCE/SEI 7.
 - 1. The term "withstand" means "the unit will remain in place without separation of any parts from the device when subjected to the seismic forces specified".

1.4 ACTION SUBMITTALS

- A. Product Data: For each air-handling unit indicated.
 - 1. Unit dimensions and weight.
 - 2. Cabinet material, metal thickness, finishes, insulation, and accessories.

3. Fans:
 - a. Certified fan-performance curves with system operating conditions indicated.
 - b. Certified fan-sound power ratings.
 - c. Fan construction and accessories.
 - d. Motor ratings, electrical characteristics, and motor accessories.
 4. Certified coil-performance ratings with system operating conditions indicated.
 5. Dampers, including housings, linkages, and operators.
 6. Filters with performance characteristics.
- B. Delegated-Design Submittal: For vibration isolation and seismic restraints indicated to comply with performance requirements and design criteria, including analysis data signed and sealed by the qualified professional engineer responsible for their preparation.
1. Vibration Isolation Base Details: Detail fabrication including anchorages and attachments to structure and to supported equipment. Include adjustable motor bases, rails, and frames for equipment mounting.
 2. Design Calculations: Calculate requirements for selecting vibration isolators and seismic restraints and for designing vibration isolation bases.

1.5 INFORMATIONAL SUBMITTALS

- A. Coordination Drawings: Floor plans and other details, drawn to scale, on which the following items are shown and coordinated with each other, using input from installers of the items involved:
1. Mechanical-room layout and relationships between components and adjacent structural and mechanical elements.
 2. Support location, type, and weight.
 3. Field measurements.
- B. Seismic Qualification Certificates: For air-handling units, accessories, and components, from manufacturer.
1. Basis for Certification: Indicate whether withstand certification is based on actual test of assembled components or on calculation.
 2. Dimensioned Outline Drawings of Equipment Unit: Identify center of gravity and locate and describe mounting and anchorage provisions.
 3. Detailed description of equipment anchorage devices on which the certification is based and their installation requirements.
- C. Source quality-control reports.
- D. Field quality-control reports.

1.6 CLOSEOUT SUBMITTALS

- A. Operation and Maintenance Data: For air-handling units to include in emergency, operation, and maintenance manuals.

1.7 MAINTENANCE MATERIAL SUBMITTALS

- A. Furnish extra materials that match products installed and that are packaged with protective covering for storage and identified with labels describing contents.
 - 1. Filters: 2 set(s) for each AHU, and MUA-1.
 - 2. Gaskets: 2 set(s) for each access door.
 - 3. Fan Belts: 2 set(s) for each air-handling unit fans with belt drives.

1.8 QUALITY ASSURANCE

- A. Electrical Components, Devices, and Accessories: Listed and labeled as defined in NFPA 70, by a qualified testing agency, and marked for intended location and application.
- B. NFPA Compliance: Comply with NFPA 90A for design, fabrication, and installation of air-handling units and components.
- C. ARI Certification: Air-handling units and their components shall be factory tested according to ARI 430, "Central-Station Air-Handling Units," and shall be listed and labeled by ARI.
- D. ASHRAE Compliance: Applicable requirements in ASHRAE 62.1, Section 5 - "Systems and Equipment" and Section 7 - "Construction and Startup."
- E. ASHRAE/IESNA 90.1 Compliance: Applicable requirements in ASHRAE/IESNA 90.1, Section 6 - "Heating, Ventilating, and Air-Conditioning."
- F. Comply with NFPA 70.

1.9 COORDINATION

- A. Coordinate sizes and locations of concrete bases with actual equipment provided.
- B. Coordinate sizes and locations of structural-steel support members, if any, with actual equipment provided.

PART 2 - PRODUCTS

2.1 MANUFACTURERS:

- A. Manufacturers: Provide products from one of the following:

1. AAON (Basis of Design)
2. Trane
3. York/Johnson Controls
4. Or Approved Equal

2.2 UNIT CASINGS

A. General Fabrication Requirements for Casings:

1. Forming: Form walls, roofs, and floors with at least two breaks at each joint.
2. Double wall with solid internal wall construction (AHU-1, and AHU-2), and MUA-1, 16 ga. Minimum.
3. Casing Joints: Sheet metal screws or pop rivets.
4. Sealing: Seal all joints with water-resistant sealant.
5. Factory Finish for Galvanized-Steel Casings: Immediately after cleaning and pretreating, apply manufacturer's standard two-coat, baked-on enamel finish, consisting of prime coat and thermosetting topcoat.
6. Casing Coating: Powder-baked enamel
7. Airstream Surfaces: Surfaces in contact with the airstream shall comply with requirements in ASHRAE 62.1.

B. Casing Insulation and Adhesive:

1. Materials: ASTM C 1071, Type II
2. Location and Application: Factory applied with adhesive and mechanical fasteners to the internal surface of section panels downstream from, and including, the cooling-coil section.
 - a. Liner Adhesive: Comply with ASTM C 916, Type I.
 - b. Mechanical Fasteners: Galvanized steel, suitable for adhesive attachment, mechanical attachment, or welding attachment to duct without damaging liner when applied as recommended by manufacturer and without causing leakage in cabinet.
 - c. Liner materials applied in this location shall have air-stream surface coated with a temperature-resistant coating or faced with a plain or coated fibrous mat or fabric depending on service-air velocity.
3. Location and Application: Encased between outside and inside casing.

C. Inspection and Access Panels and Access Doors:

1. Panel and Door Fabrication: Formed and reinforced, single- or double-wall and insulated panels of same materials and thicknesses as casing.
2. Inspection and Access Panels:
 - a. Fasteners: Two or more camlock type for panel lift-out operation. Arrangement shall allow panels to be opened against air-pressure differential.

- b. Gasket: Neoprene, applied around entire perimeters of panel frames.
 - c. Size: Large enough to allow inspection and maintenance of air-handling unit's internal components.
3. Access Doors:
- a. Hinges: A minimum of two ball-bearing hinges or stainless-steel piano hinge and two wedge-lever-type latches, operable from inside and outside. Arrange doors to be opened against air-pressure differential.
 - b. Gasket: Neoprene, applied around entire perimeters of panel frames.
 - c. Size: At least 24 inches wide by full height of unit casing up to a maximum height of 48 inches.
4. Locations and Applications:
- a. Fan Section: Doors and inspection and access panels.
 - b. Coil Section: Inspection and access panel.
 - c. Damper Section: access panels
 - d. Filter Section: Doors large enough to allow periodic removal and installation of filters.
 - e. Mixing Section: Doors.
 - f. Locate all doors on one side of AHU for a small mechanical room.
- D. Condensate Drain Pans (AHU-1):
- 1. Fabricated with two percent slope in at least two planes to collect condensate from cooling coils (including coil piping connections, coil headers, and return bends) to direct water toward drain connection.
 - a. Length: Extend drain pan downstream from leaving face to comply with ASHRAE 62.1.
 - b. Depth: A minimum of 2 inches deep.
 - 2. Formed sections
 - 3. Double-wall, stainless-steel sheet with space between walls filled with foam insulation and moisture-tight seal.
 - 4. Drain Connection: Located at lowest point of pan and sized to prevent overflow. Terminate with threaded nipple on both ends of pan.
 - a. Minimum Connection Size: NPS 1
 - 5. Pan-Top Surface Coating: Asphaltic waterproofing compound.
- E. Air-Handling-Unit Mounting Frame: Formed galvanized-steel channel or structural channel supports, designed for low deflection, welded with integral lifting lugs.

1. Seismic Fabrication Requirements: Fabricate mounting base and attachment to air-handling unit sections, accessories, and components with reinforcement strong enough to withstand seismic forces defined in Section 15070 "Vibration and Seismic Controls for HVAC" when air-handling unit frame is anchored to building structure.

2.3 FAN, DRIVE, AND MOTOR SECTION

- A. Fan and Drive Assemblies: Statically and dynamically balanced and designed for continuous operation at maximum-rated fan speed and motor horsepower.
 1. Shafts: Designed for continuous operation at maximum-rated fan speed and motor horsepower, and with field-adjustable alignment.
 - a. Turned, ground, and polished hot-rolled steel with keyway. Ship with a protective coating of lubricating oil.
 - b. Designed to operate at no more than 70 percent of first critical speed at top of fan's speed range.
- B. Plenum Fan Housings (AHU-1): Steel frame and panel; fabricated without fan scroll and volute housing.
- C. Backward-Inclined, Centrifugal Fan Wheels (AHU-2): Single-width-single-inlet and double-width-double-inlet construction with curved inlet flange, backplate, backward-inclined blades welded or riveted to flange and backplate; cast-iron or cast-steel hub riveted to backplate and fastened to shaft with set screws.
- D. Forward-Curved, Centrifugal Fan Wheels: not acceptable for AHU-1, and AHU-2, and acceptable for MUA-1.
- E. Airfoil, Centrifugal Fan Wheels: Smooth-curved inlet flange, backplate, and hollow die-formed airfoil-shaped blades continuously welded at tip flange and backplate; cast-iron or cast-steel hub riveted to backplate and fastened to shaft with set screws.
- F. Fan Shaft Bearings:
 1. Prelubricated and Sealed, Ball Bearings: Self-aligning, pillow-block type with a rated life of 120,000 hours according to ABMA 9.
 2. Grease-Lubricated, Tapered-Roller Bearings: Self-aligning, pillow-block type with double-locking collars and 2-piece, cast-iron housing with grease lines extended to outside unit and a rated life of 120,000 hours according to ABMA 11.
 3. Grease-Lubricated Bearings: Self-aligning, pillow-block-type, ball or roller bearings with adapter mount and two-piece, cast-iron housing with grease lines extended to outside unit.
- G. Belt Drives: Factory mounted, with adjustable alignment and belt tensioning, and with 1.5 service factor based on fan motor.

1. Pulleys: Cast iron or cast steel with split, tapered bushing; dynamically balanced at factory.
 2. Motor Pulleys: Adjustable pitch for use with 5-hp motors and smaller.
 3. Belts: Oil resistant, nonsparking, and nonstatic; in matched sets for multiple-belt drives.
 4. Belt Guards: Comply with requirements specified by OSHA and fabricate according to SMACNA's "HVAC Duct Construction Standards"; 0.1046-inch-thick, 3/4-inch diamond-mesh wire screen, welded to steel angle frame; prime coated.
- H. Discharge Dampers: Heavy-duty steel assembly with channel frame and sealed ball bearings, and parallel blades constructed of two plates formed around and welded to shaft, with blades linked out of air stream to single control lever.
- I. Internal Vibration Isolation and Seismic Control: Fans shall be factory mounted with manufacturer's standard restrained vibration isolation mounting devices having a minimum static deflection of 2-inches.
1. Seismic Fabrication Requirements: Fabricate fan section, internal mounting frame and attachment to fans, fan housings, motors, casings, accessories, and other fan section components with reinforcement strong enough to withstand seismic forces defined in Section 15070 "Vibration and Seismic Controls for HVAC" when fan-mounting frame and air-handling-unit mounting frame are anchored to building structure.
- J. Motor: Comply with NEMA designation, temperature rating, service factor, enclosure type, and efficiency requirements for motors specified in Section 15700 "Common Motor Requirements for HVAC Equipment".
1. Enclosure Type: Totally enclosed, fan cooled.
 2. NEMA Premium (TM) efficient motors as defined in NEMA MG 1.
 3. Motor Sizes: Minimum size as indicated. If not indicated, large enough so driven load will not require motor to operate in service factor range above 1.0.
 4. Controllers, Electrical Devices, and Wiring: Comply with requirements for electrical devices and connections specified in electrical Sections.
 5. Mount unit-mounted disconnect switches on interior of unit.

2.4 COIL SECTION

- A. General Requirements for Hot Water and DX Cooling Coil Sections:
1. Comply with ARI 410.
 2. Fabricate coil section to allow removal and replacement of coil for maintenance and to allow in-place access for service and maintenance of coil(s).
 3. Coils shall not act as structural component of unit.
 4. Seismic Fabrication Requirements: Fabricate coil section, internal mounting frame and attachment to coils, and other coil section components with reinforcement strong enough to withstand seismic forces defined in Section 15070 "Vibration and Seismic Controls for HVAC" when coil-

mounting frame and air-handling-unit mounting frame are anchored to building structure.

2.5 AIR FILTRATION SECTION (AHU-1, and AHU-2):

A. General Requirements for Air Filtration Section:

1. Comply with NFPA 90A.
2. Provide minimum arrestance according to ASHRAE 52.1, and a minimum efficiency reporting value (MERV) according to ASHRAE 52.2.
3. Provide filter holding frames arranged for flat or angular orientation, with access doors on both sides of unit. Filters shall be removable from one side or lifted out from access plenum.

B. Disposable Panel Filters:

1. Factory-fabricated, viscous-coated, flat-panel type.
2. Thickness: 2 inch.
3. Initial Resistance: See Drawings
4. Recommended Final Resistance: See Drawings
5. Merv (ASHRAE 52.2): 8.
6. Media: Interlaced glass fibers sprayed with nonflammable adhesive and antimicrobial agent.
7. Frame: Galvanized steel, with metal grid on outlet side, steel rod grid on inlet side, hinged, and with pull and retaining handles.

C. Extended-Surface, Disposable Pleated, Panel Filters:

1. Factory-fabricated, dry, extended-surface type.
2. Thickness: 4 inches
3. Dust-Holding Capacity:
4. Initial Resistance: See drawings
5. Recommended Final Resistance: See drawings
6. Merv (ASHRAE 52.2): 11
7. Media: Fibrous material formed into Deep-V-shaped pleats with antimicrobial agent and held by self-supporting wire grid.
8. Media-Grid Frame: Galvanized steel.
9. Mounting Frames: Welded, galvanized steel, with gaskets and fasteners, suitable for bolting together into built-up filter banks.

D. Filter Gage:

1. 3-1/2-inch-diameter, diaphragm-actuated dial in metal case.
2. Vent valves.
3. Black figures on white background.
4. Front recalibration adjustment.
5. 2 percent of full-scale accuracy.
6. Range: 0- to 1.0-inch w.g., and 0- to 2.0-inch w.g.

7. Accessories: Static-pressure tips with integral compression fittings, 1/4-inch aluminum tubing, and 2- or 3-way vent valves.

2.6 AIR FILTRATION (MUA-1):

1. Provide 2-inch TA filters.

2.7 DAMPERS

- A. General Requirements for Dampers: Low Leakage type, according to AMCA 500, "Laboratory Methods for Testing Dampers for Rating," shall not exceed 10 CFM per SF of damper area and of air quantity at 2,000-fpm face velocity through damper and 4-inch w.g. pressure differential.
- B. Electronic Damper Operators:
 1. Direct-coupled type designed for minimum 60,000 full-stroke cycles at rated torque.
 2. Electronic damper position indicator shall have visual scale indicating percent of travel and 120-V, 1phase, feedback signal.
 3. Operator Motors:
 - a. Comply with NEMA designation, temperature rating, service factor, enclosure type, and efficiency requirements for motors specified in Section 15700 "Common Motor Requirements for HVAC Equipment".
 - b. Size to operate with sufficient reserve power to provide smooth modulating action or two-position action.
 - c. Permanent Split-Capacitor or Shaded-Pole Type: Gear trains completely oil immersed and sealed. Equip spring-return motors with integral spiral-spring mechanism in housings designed for easy removal for service or adjustment of limit switches, auxiliary switches, or feedback potentiometer.
 4. Size dampers for running torque calculated as follows:
 - a. Parallel-Blade Damper with Edge Seals: 7 inch-lb/sq. ft. of damper.
 - b. Opposed-Blade Damper with Edge Seals: 5 inch-lb/sq. ft. of damper.
 - c. Parallel-Blade Damper without Edge Seals: 4 inch-lb/sq. ft. of damper.
 - d. Opposed-Blade Damper without Edge Seals: 3 inch-lb/sq. ft. of damper.
 - e. Dampers with 2- to 3-Inch wg of Pressure Drop or Face Velocities of 1000 to 2500 fpm: Increase running torque by 1.5.
 - f. Dampers with 3- to 4-Inch wg of Pressure Drop or Face Velocities of 2500 to 3000 fpm: Increase running torque by 2.0.
 5. Coupling: V-bolt and V-shaped, toothed cradle.
 6. Overload Protection: Electronic overload or digital rotation-sensing circuitry.
 7. Fail-Safe Operation: Mechanical, spring-return mechanism with external, manual gear release on nonspring-return actuators.
 8. Power Requirements (Modulating): Maximum 120-V 1 phase.

9. Proportional Signal: 2- to 10-V dc or 4 to 20 mA, and 2- to 10-V dc position feedback signal.
10. Temperature Rating: 40 to 104 deg F
11. Run Time: 12 seconds open, 5 seconds closed

2.8 CAPACITIES AND CHARACTERISTICS

A. Casing:

1. Outside Casing: Galvanized steel, minimum 0.079 inch thick.
2. Inside Casing: Galvanized steel, perforated, minimum 0.079 inch thick.
3. Floor Plate: Galvanized steel, minimum 0.079 inch thick.
4. Static-Pressure Classifications for Unit Sections before and after Fans: 3-inch wg.

B. Supply Fan AHU-1, 2, and MUA-1: See drawings for additional information on capacities and characteristics.

C. Preheat Coil: See drawings for additional information on capacities and characteristics.

1. Headers:

- a. Cast iron with cleaning plugs and drain and air vent tappings extended to exterior of unit.
- b. Seamless copper tube with brazed joints, prime coated.
- c. Fabricated steel, with brazed joints, prime coated.
- d. Provide insulated cover to conceal headers exposed outside casings.

2. Frames: Channel frame, 0.079-inch thick galvanized steel

3. Number of Rows: 2 min.

4. Coil Working-Pressure Ratings: 200 psig, 325 deg F

5. Heating Hot Water:

- | | |
|---------------------------------|--------------|
| a. Water Flow: | See Drawings |
| b. Maximum Water Pressure Drop: | “ |
| c. Entering-Water Temperature: | “ |
| d. Leaving-Water Temperature: | “ |
| e. Tube Velocity: | Max, 5 FPS |

6. Coating: Phenolic

D. Cooling Coil- DX, AHU-1, only: See drawings for additional information on capacities and characteristics.

E.

1. Headers:

- a. Cast iron with cleaning plugs and] drain and air vent tappings extended to exterior of unit.
 - b. Seamless copper tube with brazed joints, prime coated.
 - c. Provide insulated cover to conceal headers exposed outside casings.
2. Frames: Channel frame, 0.079-inch thick galvanized steel
 3. Number of Rows: minimum of 4,
 4. Coil Working-Pressure Ratings: 200 psig, 325 deg F
 5. Refrigerant DX coil R-410.

2.9 SOURCE QUALITY CONTROL

- A. Fan Sound-Power Level Ratings: Comply with AMCA 301, "Methods for Calculating Fan Sound Ratings from Laboratory Test Data." Test fans according to AMCA 300, "Reverberant Room Method for Sound Testing of Fans." Fans shall bear AMCA-certified sound ratings seal.
- B. Fan Performance Rating: Factory test fan performance for airflow, pressure, power, air density, rotation speed, and efficiency. Rate performance according to AMCA 210, "Laboratory Methods of Testing Fans for Aerodynamic Performance Rating."
- C. Water Coils: Factory tested to 300 psig according to ARI 410 and ASHRAE 33.

PART 3 - EXECUTION

3.1 EXAMINATION

- A. Examine areas and conditions, with Installer present, for compliance with requirements for installation tolerances and other conditions affecting performance of the Work.
- B. Examine casing insulation materials and filter media before air-handling unit installation. Reject insulation materials and filter media that are wet, moisture damaged, or mold damaged.
- C. Examine roughing-in for hydronic, and condensate drainage piping systems and electrical services to verify actual locations of connections before installation.
- D. Proceed with installation only after unsatisfactory conditions have been corrected.

3.2 INSTALLATION

- A. Equipment Mounting:

1. Install air-handling unit, AHU-1 on 4-inch concrete housekeeping equipment bases and attached to existing concrete floor. Comply with requirements for equipment bases and foundations specified in Section 03000 "Cast-in-Place Concrete".
 2. Comply with requirements for vibration isolation and seismic control devices specified in Section 15070 "Vibration and Seismic Controls for HVAC".
 3. Suspend and support AHU-2, and MUA-1 from structure above. Provide vibration isolators with hanger rods.
- B. Suspended Units: AHU-2, and MUA-1, but not utilized for AHU-1
- C. Arrange installation of units to provide access space around air-handling units for service and maintenance.
- D. Do not operate fan system until filters (temporary or permanent) are in place. Replace temporary filters used during construction and testing, with new, clean filters.
- E. Install filter-gage, static-pressure taps upstream and downstream of filters. Mount filter gages on outside of filter housing or filter plenum in accessible position. Provide filter gages on filter banks, installed with separate static-pressure taps upstream and downstream of filters.
- F. Provide pressure control of static pressure in the supply duct for VAV operation of AHU-1. Sepoint shall be 1.0" WC (adj.)

3.3 CONNECTIONS

- A. Comply with requirements for piping specified in other Sections. Drawings indicate general arrangement of piping, fittings, and specialties.
- B. Install piping adjacent to air-handling unit to allow service and maintenance.
- C. Connect piping to air-handling units mounted on vibration isolators with flexible connectors.
- D. Connect condensate drain pans using NPS 1-1/4, ASTM B 88, Type M copper tubing. Extend to nearest floor drain. Construct deep trap at connection to drain pan and install cleanouts at changes in direction.
- E. Hot-Water Piping: Comply with applicable requirements in Section 15180 "Hydronic Piping" and Section 15185 "Hydronic Piping Specialties." Install shutoff valve and union or flange at each coil supply connection. Install balancing valve and union or flange at each coil return connection.
- F. Connect duct to air-handling units with flexible connections. Comply with requirements in Section 15800 "Ductwork and Accessories".

3.4 FIELD QUALITY CONTROL

- A. Manufacturer's Field Service: Engage a factory-authorized service representative to inspect, test, and adjust components, assemblies, and equipment installations, including connections.
- B. Perform tests and inspections.
 - 1. Manufacturer's Field Service: Engage a factory-authorized service representative to inspect components, assemblies, and equipment installations, including connections, and to assist in testing.
- C. Tests and Inspections:
 - 1. Leak Test: After installation, fill water and steam coils with water, and test coils and connections for leaks.
 - 2. Charge refrigerant coils with refrigerant and test for leaks.
 - 3. Fan Operational Test: After electrical circuitry has been energized, start units to confirm proper motor rotation and unit operation.
 - 4. Test and adjust controls and safeties. Replace damaged and malfunctioning controls and equipment.
- D. Air-handling unit or components will be considered defective if unit or components do not pass tests and inspections.
- E. Prepare test and inspection reports.

3.5 STARTUP SERVICE

- A. Engage a factory-authorized service representative to perform startup service.
 - 1. Complete installation and startup checks according to manufacturer's written instructions.
 - 2. Verify that shipping, blocking, and bracing are removed.
 - 3. Verify that unit is secure on mountings and supporting devices and that connections to piping, ducts, and electrical systems are complete. Verify that proper thermal-overload protection is installed in motors, controllers, and switches.
 - 4. Verify proper motor rotation direction, free fan wheel rotation, and smooth bearing operations. Reconnect fan drive system, align belts, and install belt guards.
 - 5. Verify that bearings, pulleys, belts, and other moving parts are lubricated with factory-recommended lubricants.
 - 6. Verify that outdoor- relief, and return-air mixing dampers open and close, and maintain minimum outdoor-air setting.
 - 7. Comb coil fins for parallel orientation.
 - 8. Install new, clean filters.
 - 9. Verify that manual and automatic volume control and fire and smoke dampers in connected duct systems are in fully open position.

- B. Starting procedures for air-handling units include the following:
 - 1. Energize motor; verify proper operation of motor, drive system, and fan wheel. Adjust fan to indicated rpm. Replace fan and motor pulleys as required to achieve design conditions.
 - 2. Measure and record motor electrical values for voltage and amperage.
 - 3. Manually operate dampers from fully closed to fully open position and record fan performance.
 - 4. Test and operate economizer fan, EF-5 for meeting operation and control requirements.

3.6 ADJUSTING

- A. Adjust damper linkages for proper damper operation.
- B. Comply with requirements in Section 15950 "Testing, Adjusting, and Balancing for HVAC" for air-handling system testing, adjusting, and balancing.

3.7 CLEANING

- A. After completing system installation and testing, adjusting, and balancing air-handling unit and air-distribution systems and after completing startup service, clean air-handling units internally to remove foreign material and construction dirt and dust. Clean fan wheels, cabinets, dampers, coils, and filter housings, and install new, clean filters.

3.8 DEMONSTRATION

- A. Engage a factory-authorized service representative to train Owner's maintenance personnel to adjust, operate, and maintain air-handling units.

END OF SECTION

SECTION 15730

SPLIT-SYSTEM HEAT PUMPS

PART 1 - GENERAL

1.1 SUMMARY

- A. Section includes split-system Heat Pump units consisting of separate Heat Pump (evaporator-fan) and Condensing Unit (compressor-condenser) components. These units shall be used to provide environmental control in the Toll Booths.

1.2 ACTION SUBMITTALS

- A. Product Data: For each type of product indicated.
- B. Shop Drawings: Include plans, elevations, sections, details, and attachments to other work.
 - 1. Detail equipment assemblies and indicate dimensions, weights, loads, required clearances, method of field assembly, components, and location and size of each field connection.

1.3 INFORMATIONAL SUBMITTALS

- A. Warranty: Sample of special warranty.

1.4 CLOSEOUT SUBMITTALS

- A. Operation and maintenance data.

1.5 QUALITY ASSURANCE

- A. Electrical Components, Devices, and Accessories: Listed and labeled as defined in NFPA 70, by a qualified testing agency, and marked for intended location and application.
- B. ASHRAE Compliance:
 - 1. Fabricate and label refrigeration system to comply with ASHRAE 15, "Safety Standard for Refrigeration Systems."
 - 2. ASHRAE Compliance: Applicable requirements in ASHRAE 62.1, Section 4 - "Outdoor Air Quality," Section 5 - "Systems and Equipment," Section 6 - "Procedures," and Section 7 - "Construction and System Start-up."
- C. ASHRAE/IESNA Compliance: Applicable requirements in ASHRAE/IESNA 90.1.

1.6 WARRANTY

- A. Special Warranty: Manufacturer's standard form in which manufacturer agrees to repair or replace components of split-system air-conditioning units that fail in materials or workmanship within specified warranty period.
1. Warranty Period:
 - a. For Compressor: Seven year(s) from date of Substantial Completion.
 - b. For Parts: Five year(s) from date of Substantial Completion.
 - c. For Labor: One year(s) from date of Substantial Completion.

PART 2 - PRODUCTS

2.1 MANUFACTURERS

- A. Manufacturer: Subject to compliance with requirements, provide product by the following manufacturer:
1. Mitsubishi Electric (Basis of Design)
 2. No Approved Equal

2.2 INDOOR HEAT PUMP UNITS (5 TONS OR LESS)

- A. Roof-Mounted Heat Pump/ Evaporator-Fan Components:
1. Provide roof-mounted heat pumps on roof of each toll booth. The heat pump (indoor evaporator unit) on the roof shall contain an insulated enclosure for outdoor environment. Provide ceiling type air distribution box that is connected to bottom of the heat pump with supply and return air distribution. The split system condensing unit connected to the heat pump shall be roof-mounted, and located on the same roof of the toll booth a few feet away from the heat pump. Refrigerant piping shall be installed between the heat pump and the condensing unit.
 2. Cabinet: Enameled steel with removable panels on front and ends in color to be selected in accordance with the General Provisions for Construction, and discharge drain pans with drain connection.
 3. Refrigerant Coil: Copper tube, with mechanically bonded aluminum fins and thermal-expansion valve. Comply with ARI 206/110.
 4. Fan: Direct drive, centrifugal.
 5. Fan Motors:
 - a. Comply with NEMA designation, temperature rating, service factor, enclosure type, and efficiency requirements specified in Section 15700 "Common Motor Requirements for HVAC Equipment".
 - b. Multitapped, multispeed with internal thermal protection and permanent lubrication.

- c. Enclosure Type: Totally enclosed, fan cooled.
 - d. NEMA Premium (TM) efficient motors as defined in NEMA MG 1.
 - e. Controllers, Electrical Devices, and Wiring: Comply with requirements for electrical devices and connections specified in electrical Sections.
 - f. Mount unit-mounted disconnect switches on exterior of unit.
6. Airstream Surfaces: Surfaces in contact with the airstream shall comply with requirements in ASHRAE 62.1.
7. Condensate Drain Pans:
- a. Fabricated with two percent slope in at least two planes to collect condensate from cooling coils (including coil piping connections, coil headers, and return bends) and to direct water toward drain connection.
 - 1) Length: Extend drain pan downstream from leaving face to comply with ASHRAE 62.1.
 - 2) Depth: A minimum of 1 inch deep.
 - b. Drain Connection: Located at lowest point of pan and sized to prevent overflow. Terminate with threaded nipple on both ends of pan.
 - 1) Minimum Connection Size: NPS 1-1/4 inch.
 - c. Pan-Top Surface Coating: Asphaltic waterproofing compound.
8. Air Filtration Section:
- a. General Requirements for Air Filtration Section:
 - 1) Comply with NFPA 90A.
 - 2) Minimum Arrestance: According to ASHRAE 52.1 and MERV according to ASHRAE 52.2.
 - 3) Filter-Holding Frames: Arranged for flat or angular orientation, with access doors on both sides of unit. Filters shall be removable from one side or lifted out from access plenum.

2.3 OUTDOOR CONDENSING UNITS (5 TONS OR LESS)

A. Air-Cooled, Condensing unit (Compressor-Condenser) Components:

1. Provide condensing unit for each heat pump for each Toll Booth.
2. Casing: Steel, finished with baked enamel in color to be selected in accordance with the General Provisions for Construction, with removable panels for access to controls, weep holes for water drainage, and mounting holes in base. Provide brass service valves, fittings, and gage ports on exterior of casing.
3. Compressor: Hermetically sealed with crankcase heater and mounted on vibration isolation device. Compressor motor shall have thermal- and current-sensitive overload devices, start capacitor, relay, and contactor.

- a. Compressor Type: Scroll.
 - b. Two-speed compressor motor with manual-reset high-pressure switch and automatic-reset low-pressure switch.
 - c. Refrigerant Charge: R-410A.
 - d. Refrigerant Coil: Copper tube, with mechanically bonded aluminum fins and liquid subcooler. Comply with ARI 206/110.
4. Fan: Aluminum-propeller type, directly connected to motor.
 5. Motor: Permanently lubricated, with integral thermal-overload protection.
 6. Low Ambient Kit: Permits operation down to 0 deg F.
 7. Mounting Base: Polyethylene.

2.4 ACCESSORIES

- A. Control equipment and sequence of operation are specified in Section 15920 "Direct Digital Control (DDC) System for HVAC" and Section 15990 "Sequence of Operations for HVAC DDC." Provide manufacturer's local equipment control panels: one for each split system units (HP/CU). Provide wireless wall-mounted controller with temperature sensor and fan speeds.
- B. Thermostat: Low voltage with subbase to control compressor and evaporator fan.
 1. Compressor time delay.
 2. 24-hour time control of system stop and start.
 3. Liquid-crystal display indicating temperature, set-point temperature, time setting, operating mode, and fan speed.
 4. Fan-speed selection including auto setting.
- C. Automatic-reset timer to prevent rapid cycling of compressor.
- D. Refrigerant Line Kits: Soft-annealed copper suction and liquid lines factory cleaned, dried, pressurized, and sealed; factory-insulated suction line with flared fittings at both ends.
- E. Drain: For condensate. Drain to gutters with air gap, as noted on the drawings.
- F. Additional Monitoring:
 1. Monitor constant and variable motor loads.
 2. Monitor cooling load.
 3. Monitor air distribution static pressure and ventilation air volumes.
 4. Provide toll booth room temperature sensor for remote monitoring via the BMS.

2.5 CAPACITIES AND CHARACTERISTICS: Refer to drawings for Capacity data:

- A. Indoor Unit:
 1. Fan Motor Electrical Characteristics: Refer to the drawings.

- B. Outdoor Unit:
 - 1. Type: Air cooled.
 - 2. Electrical Characteristics: Refer to drawings.

PART 3 - EXECUTION

3.1 INSTALLATION

- A. Provide units level and plumb on the roof of the toll booths.
- B. Provide heat pump (evaporator-fan) components using manufacturer's standard mounting devices securely fastened to aluminum beams extending to both sides of the toll booth wall structure, as required for the supporting the heat pump unit.
- C. Provide weatherproof removable enclosure for the indoor Heat Pump unit, as noted on the drawings.
- D. Provide roof-mounted, compressor-condenser components on equipment supports. Anchor units to support beams extending to both sides of the toll booth wall structures. with removable, cadmium-plated fasteners, as noted on the drawings. Coordinate with details on structural drawings.
- E. Equipment Mounting:
 - 1. Comply with requirements for vibration isolation and seismic control devices specified in Section 15070 "Vibration and Seismic Controls for HVAC".
- F. Provide and connect pre-charged refrigerant tubing to component's quick-connect fittings. Install tubing to allow access to unit.

3.2 CONNECTIONS

- A. Where piping is installed adjacent to unit, allow space for service and maintenance of unit.
- B. Provide condensate piping from the Heat Pump unit to the storm drainage system as noted on the drawing. The condensate drainage system is also shown on the plumbing drawings as draining to an approved sanitary plumbing fixture with an air gap.
- C. Provide temperature sensor (2nd sensor), and interlock with new BMS for remote monitoring.

3.3 FIELD QUALITY CONTROL

- A. Perform tests and inspections.

1. Manufacturer's Field Service: Engage a factory-authorized service representative to inspect components, assemblies, and equipment installations, including connections, and to assist in testing.

B. Tests and Inspections:

1. Leak Test: After installation, charge system and test for leaks. Repair leaks and retest until no leaks exist.
2. Operational Test: After electrical circuitry has been energized, start units to confirm proper motor rotation and unit operation.
3. Test and adjust controls and safeties. Replace damaged and malfunctioning controls and equipment.

C. Remove and replace malfunctioning units and retest as specified above.

D. Prepare test and inspection reports.

3.4 DEMONSTRATION

- A. Engage a factory-authorized service representative to train Owner's maintenance personnel to adjust, operate, and maintain units.

END OF SECTION

SECTION 15740

COMPUTER ROOM AIR CONDITIONERS MOUNTED UNITS

PART 1 - GENERAL

1.1 SUMMARY

- A. Section includes Wall-mounted, computer-room air conditioners. Units include AC-1/2 and remote condensing units, CU-2/3 for the MTA IT room.

1.2 ACTION SUBMITTALS

- A. Product Data: For each type of product.
- B. Shop Drawings: For computer-room air conditioners.
 - 1. Include plans, elevations, sections, and attachment details.
 - 2. Include details of equipment assemblies. Indicate dimensions, weights, loads, required clearances, method of field assembly, components, and location and size of each field connection.
 - 3. Include diagrams for power, signal, and control wiring.
- C. Color Samples: For unit cabinet, discharge grille, and for each color and texture specified.

1.3 INFORMATIONAL SUBMITTALS

- A. Coordination Drawings: Plans, elevations, and other details, drawn to scale, using input from installers of the items involved.
- B. Seismic Qualification Certificates: For computer-room air conditioners, accessories, and components, from manufacturer.
- C. Field quality-control reports.
- D. Sample warranty.

1.4 CLOSEOUT SUBMITTALS

- A. Operation and maintenance data.

1.5 WARRANTY

- A. Special Warranty: Manufacturer agrees to repair or replace components of computer-room air conditioners that fail in materials or workmanship within specified warranty period.

1. Warranty Period for Compressors: Manufacturer's standard, but not less than five years from date of Substantial Completion.
2. Warranty Period for Control Boards: Manufacturer's standard, but not less than three years from date of Substantial Completion.

PART 2 - PRODUCTS

2.1 MANUFACTURERS

- A. Manufacturers upon shop drawing approval shall be one of the following:
 1. Mitsubishi Basis of design)
 2. Fujitsu
 3. Carrier
 4. Daikin

2.2 PERFORMANCE REQUIREMENTS

- A. Seismic Performance: Computer-room air-conditioners, ceiling-mounted units shall withstand the effects of earthquake motions determined according to ASCE/SEI 7.
 1. The term "withstand" means "the unit will remain in place without separation of any parts when subjected to the seismic forces specified.
- B. Electrical Components, Devices, and Accessories: Listed and labeled as defined in NFPA 70, by a qualified testing agency, and marked for intended location and application.
- C. ASHRAE Compliance:
 1. Fabricate and label refrigeration system to comply with ASHRAE 15, "Safety Standard for Refrigeration Systems."
 2. ASHRAE Compliance: Applicable requirements in ASHRAE 62.1, Section 4 - "Outdoor Air Quality," Section 5 - "Systems and Equipment," Section 6 - "Ventilation Rate Procedures," and Section 7 - "Construction and Startup."
- D. ASHRAE/IES Compliance: Applicable requirements in ASHRAE/IES 90.1.
- E. ASME Compliance: Fabricate and label water-cooled condenser shell to comply with ASME Boiler and Pressure Vessel Code: Section VIII, "Pressure Vessels," Division 1.

2.3 MANUFACTURED UNITS

- A. Description: Self-contained, factory assembled, prewired, and prepiped; consisting of cabinet, fan, filters, and controls.

1. Mounting Configuration: Exposed in the space.
- B. Cabinet: Galvanized steel serviceable from one side, with baked-enamel finish, white, insulated with 1/2-inch- (13-mm-) thick duct liner, and mounting bracket attached to the unit.
1. Integral factory-supplied supply and return grille in the wall-mounted unit with filter.
 2. Unit with two-speed, centrifugal direct-drive fan.
 3. Finish of Interior Surfaces: Surfaces in contact with the airstream shall comply with requirements in ASHRAE 62.1.
- C. Supply-Air Fan:
1. Forward curved, double width, double inlet, centrifugal, with adjustable V-belt drive.
- D. Refrigeration System:
1. Compressor: Scroll, with oil strainer, internal motor overload protection, resilient suspension system, and crankcase heater.
 2. Refrigeration Circuit Components:
 - a. Low-pressure switch.
 - b. Manually reset, high-pressure switch.
 - c. Thermal-expansion valve with external equalizer.
 - d. Sight glass with moisture indicator.
 - e. Service shutoff valves.
 - f. Charging valves
 - g. Refrigerant charge.
 3. Refrigerant: R-410A.
 4. Refrigerant Evaporator Coil: Direct-expansion coil of seamless copper tubes expanded into aluminum fins.
 5. Refrigerant line sets of sufficient length to serve the unit from its remote condensing unit. The Condensing units may have be oversized to accommodate the long refrigerant lines, and/or provide larger size refrigerant lines for the pressure drops, and shall meet the required rated cooling capacities, as noted on the drawings.
 6. Provide shop drawings for the final sizing of the computer room AC and condensing units in order to accommodate the long refrigerant lines for meeting rated capacities.
 7. Refrigerant line-sweat-adapter kit to permit field brazing of refrigerant lines.
 - a. Mount stainless-steel drain pan complying with ASHRAE 62.1 and having a condensate pump unit with integral float switch, pump-motor assembly, and condensate reservoir under coil assembly.

8. Remote, Air-Cooled Refrigerant Condensing unit: Integral, copper-tube aluminum-fin coil with direct-drive, propeller fan.
 9. Split system shall have suction- and liquid-line compatible fittings and refrigerant piping for field interconnection.
- E. Filter: 1-inch- (25-mm-) thick, disposable, glass-fiber media.
1. Initial Resistance:
 2. Recommended Final Resistance: $\frac{1}{2}$ "WC
 3. Arrestance: 30 percent, according to ASHRAE 52.2.
- F. Disconnect Switch: Non-automatic, molded-case circuit breaker with handle accessible when panel is closed and capable of preventing access until switched to off position.
- G. Single point power kit permitting single electrical feed to the evaporator and condensing unit of a close-coupled system. Single power connection for both units at the condensing unit.
- H. Epoxy-coated, step-down transformer suitable for mounting on the outdoor condensing unit to provide it with 120 -V, 1 phase input power.
- I. Control System:
1. Microprocessor remote-mounted panel.
 2. Fan contactor.
 3. Compressor contactor.
 4. Compressor start capacitor.
 5. Control transformer with circuit breaker.
 6. Solid-state temperature-control modules.
 7. Time-delay relay.
 8. Smoke sensor.
 9. Filter clog switch.
 10. Alarm contacts.
 11. High-temperature thermostat.
 12. Solid-state, wall-mounted control panel with start-stop switch, remote temperature sensors and adjustable temperature set point.
 13. Remote panel to monitor and change temperature set points and sensitivities of the unit and unit alarms.
- J. Fan Motors:
1. Comply with NEMA designation, temperature rating, service factor, and efficiency requirements for motors specified in Section 15700 "Common Motor Requirements for HVAC Equipment."

- a. Motor Sizes: Minimum size as indicated. If not indicated, large enough so driven load does not require motor to operate in service factor range above 1.0.
- b. Controllers, Electrical Devices, and Wiring: Comply with requirements for electrical devices and connections specified in electrical Sections.

2.4 CAPACITIES AND CHARACTERISTICS: Refer to the Drawings for rated performance capacities and ratings.

PART 3 - EXECUTION

3.1 INSTALLATION

- A. Layout and install computer-room air conditioners and suspension system coordinated with other construction that are close to the wall-mounted evaporator units.
- B. Install computer-room air conditioners level and plumb, maintaining manufacturer's recommended clearances.
- C. Wall-mounted Computer-Room Air Conditioners: Install using wall brackets supplied by the manufacturer of size required to support weight of computer-room air conditioner.
 1. Comply with requirements for vibration isolation devices specified in Section 15070 "Vibration and Seismic Controls for HVAC. Fabricate brackets or supports as required.
 2. Comply with requirements for hangers and supports specified in Section 15071 "Hangers and Supports for HVAC Piping and Equipment."
- D. Air-Cooled Refrigerant Condenser Mounting: Install using elastomeric pads, or elastomeric mounts on concrete base. Comply with requirements for vibration isolation devices specified in Section 15070 "Vibration and Seismic Controls for HVAC."
- E. Integrate operation of AC units with FM-200 system. See fire protection drawings for deactivation sequence requirements.

3.2 CONNECTIONS

- A. Piping installation requirements are specified in other heating, ventilating, and air-conditioning Sections. Drawings indicate general arrangement of piping, fittings, and specialties.
- B. Where installing piping adjacent to computer-room air conditioners, allow space for service and maintenance.

- C. Water and Drainage Connections: Comply with applicable requirements in Section 15400" plumbing Piping." Provide adequate connections for condensate drain.
- D. Refrigerant Piping: Comply with applicable requirements in Section 15181 "Refrigerant Piping." Provide shutoff valves and piping.

3.3 FIELD QUALITY CONTROL

- A. Perform the following tests and inspections with the assistance of a factory-authorized service representative:
 - 1. Inspect for and remove shipping bolts, blocks, and tie-down straps.
 - 2. After installing computer-room air conditioners and after electrical circuitry has been energized, test for compliance with requirements.
 - 3. Operational Test: After electrical circuitry has been energized, start units to confirm proper motor rotation and unit operation.
 - 4. Test and adjust controls and safeties. Replace damaged and malfunctioning controls and equipment.
- B. Computer-room air conditioners will be considered defective if they do not pass tests and inspections.
- C. Prepare test and inspection reports.
- D. After startup service and performance test, change filters and flush humidifier.

3.4 DEMONSTRATION

- A. Engage a factory-authorized service representative to train Owner's maintenance personnel to adjust, operate, and maintain computer-room air conditioners.

END OF SECTION

SECTION 15800

DUCTWORK AND ACCESSORIES

PART 1 - GENERAL

1.1 RELATED DOCUMENTS

- A. The drawings and the specifications including SECTION 15000 "SUPPLEMENTAL MECHANICAL GENERAL REQUIREMENTS" are hereby made a part of the work of this section.

1.2 DESCRIPTION OF WORK

- A. The work covered by this Section of the specifications includes the furnishing of labor, materials, equipment, transportation, permits, inspections and incidentals and the performing of operations required to install the ductwork systems indicated.

1.3 SUBMITTALS

- A. Substitutions: As approved by Engineer, attention is also directed to Section 15000-"Substitutions", relative to competition and the (ONLY) notation. Familiarity with this section should be achieved before reading the PRODUCTS section of this specification.
- B. The items for which the submittals paragraph in Section 15000, Supplemental General Mechanical Requirements, apply are as follows:
 - 1. Ductwork.
 - 2. Ductwork accessories.
 - 3. Firestopping materials and methods.
 - 4. Louvers and dampers.
 - 5. Ductwork sealing products.
 - 6. Fire and Fire/Smoke dampers
 - 7. Complete Ductwork Layout of ductwork Systems (Shop Drawings)

PART 2 - PRODUCTS

2.1 DUCTWORK

- A. Classification of Ductwork: Low pressure ductwork: up to 2" W.G. static pressure for Outside air, Return, and exhaust ductwork, and 3" WC for all supply air ductwork. The duct pressure class shall be determined by multiplying the total static pressure scheduled in the fan schedules by 1.2. Minimum SMACNA Seal Class for supply ducts: Class A, and exhaust and return ducts: Seal Class B. Leakage Class for supply ducts: 12, supply ducts from VAV boxes to air devices: class 6, and Leakage Class for exhaust and return ducts: 24.

- B. Materials: Unless otherwise indicated low pressure ductwork shall be galvanized steel. Galvanized sheet metal shall be new galvanized steel sheets of lock forming quality with zinc coating that will not flake or peel under forming operation.
- C. Construction for Low Pressure Round and Rectangular Ductwork:
 - 1. Material: Galvanized steel conforming to ASTM A527, weight of galvanized coating shall be not less than 1-1/4 ounces total for both sides of one sq.ft. of a sheet. Construction, metal gage, and reinforcements shall conform with SMACNA "Duct Construction Standards" and NFPA 90A for 2" W.G. pressure class.
 - 2. Fittings: Shall be constructed in accordance with SMACNA Standards and shall be of the types indicated (ONLY).
 - 3. Longitudinal joints shall be Pittsburgh lockseam (ONLY). Button punch snap locks are not acceptable.
 - 4. Joints shall be sealed to SMACNA seal class B for exhaust outside and return ducts, and A for Supply ducts.

2.2 DUCTWORK ACCESSORIES

- A. Access Doors:
 - 1. Low Pressure Duct Systems: Ruskin Model ADC2, 12"x12" size, 22 gauge galvanized steel, steel on both sides of door, foam gasket seals, 1" insulation, 2 cam locks, no hinge.
- B. Counter Balanced Dampers (CBD): Aluminum frame and blades, extruded vinyl edge seals, 2-1/4" deep, set 0.06" WG.
- C. Backdraft Dampers (BDD): Ruskin Model CBD2 or American Warming and Ventilating aluminum frame and blades, extruded vinyl edge seals, field set at 0.10" W.G. pressure differential for full open operation.
- D. Flexible Duct Connections: Ventfabrics, Inc. neoprene coated glass fabric.
- E. Drawbands for Flexible Ducts: Clinch type stainless steel with screwdriver adjustment, or nylon with lever action tightening tool provided by the drawband manufacturer.
- F. Turning Vanes: (Low Pressure):
 - 1. Solid blade, mounted with the long edge down stream in accordance with duct construction details indicated.

G. Joint Sealer:

1. Hardcast DT tape and FTA-20 activator.
2. Provide waterproof sealer where watertight seal is specified.

H. Fire Dampers, and Combination Fire/Smoke dampers: Provide low leakage UL listed 555 for Fire dampers, and UL555SS for Smoke dampers.

PART 3 - EXECUTION

3.1 SURFACE CONDITIONS

A. Inspection:

1. Prior to work of this Section, carefully inspect the installed work of other trades and verify that such work is complete to the point where this installation may properly commence.
2. Verify that the duct systems may be installed in accordance with pertinent codes and regulations and the reviewed Submittals.

3.2 INSTALLATION OF DUCTWORK AND AIR DEVICES

- A. Provide and erect in accordance with the best practice of the trade ductwork shown on the drawings and as required to complete the intended installation. Make offsets as shown or required to place ductwork in proper position to avoid conflicts with other work and to allow the application of insulation and finish painting to the satisfaction of the Architect. Sizes given are "inside - clear" dimensions and not necessarily that of sheet metal. Ducts shall be arranged to adjust to "field conditions". The Sheet Metal trades shall coordinate his work with other trades. Work shall conform to ASHRAE duct construction recommendations, SMACNA "Duct Construction Standards", NFPA, and the requirements of International Mechanical code.
- B. Joint Sealing: See PRODUCTS section.
- C. Longitudinal joints: See PRODUCTS section.
- D. Turns shall be made with long radius elbows or, if physically impossible to use long radius elbows, shall be square turns with specified turning vanes. CAUTION: Turns not conforming to this requirement shall be ordered removed and replaced with properly built turns.
- E. Access Doors: Provide access doors for concealed apparatus requiring service and inspection in the duct system including but not limited to dampers, sensors and motors, and upstream and downstream from duct coils.

- F. Duct Sleeves and Prepared Openings: Install duct sleeves and prepared openings for duct mains, duct branches, and ducts passing through walls, roofs, and ceilings. Insure the proper size and location of sleeves and prepared openings. Allow one-inch clearance between duct and sleeve or one-inch clearance between insulation and sleeve for insulated ducts, except at grilles, registers, and diffusers.
- G. Duct Supports: Unless otherwise indicated, provide one-inch wide by 16 gage galvanized steel sheet metal strips on each side of ducts. Anchor risers in the center of the vertical run to allow ends or riser free vertical movements. Attach supports only to structural framing members. Do not anchor supports to metal decking unless a means is provided (architectural review required) for preventing the anchors from puncturing the metal decking. Where supports are required between structural framing members, provide suitable intermediate metal framing. Where C clamps are used, use retainer clips.
- H. Flexible Collars and Connections: Provide flexible collars between fans and ducts or casings and where ducts are of dissimilar metals, as indicated or required. For round ducts, securely fasten flexible connections using stainless steel clinch-type draw-band. Nylon drawbands may be used if installed using the drawband manufacturer's lever-action tightening tool. For rectangular ducts, lock flexible connections to metal collars.
- I. Any deviation in the duct system must be submitted as a shop drawing and stamped. CAUTION: Any deviation not submitted and favorably reviewed will be ordered removed from the system and replaced with that which is shown on the Drawings.
- J. Discrepancies between actual field conditions and the Contract Documents shall be brought to the attention of the Architect prior to fabrication.
- K. Field Changes to Ductwork: Field changes of ducts such as those required to suit the sizes of factory-fabricated equipment actually furnished shall be designed to minimize expansion and contraction. Use 4:1 transitions in field changes as well as modifications to connecting ducts.
- L. Transitions with a slope greater than 4 to 1 shall be ordered removed from the system and replaced with a transition, which meets this criteria.
- M. Joints and seams at intake and exhaust plenums and joints on intake and exhaust ductwork for a distance of 3 feet from the plenum shall be sealed watertight on the bottom and side joints and seams.
- N. Volume Dampers: Provide sufficient number of volume dampers for use for balancing the ductwork systems, and isolating HVAC equipment. Provide SMACNA standard construction volume dampers.

- O. Isolation dampers at intake and exhaust louvers shall be sealed to the ductwork to provide an airtight assembly with similar performance characteristics to the isolation damper.
- P. Fire and Fire/Smoke dampers are to be UL listed per UL Listed 555 (Fire Dampers), UL Listed 555S (Smoke Dampers), and installed as indicated on the plans.
- Q. Motorized control dampers at HVAC equipment shall be included with HVAC equipment manufacturer. Control actuators shall be electric type powered with 120v-1 phase. Refer to Spec Section 15720 Modular Indoor central Station AHU'S for additional requirements for motor operated control dampers.
- R. Operable Louvers shall be provided for intake air for the AHU'S and the Boiler room. Louvers shall be designed and constructed as indicated on the drawings, as access doors from the areaways. See Spec Section 08900 Louvers for further details.
- S. Control dampers shall be low leakage type constructed for less than 10 CFM per SF at 4" W.C. Control actuators shall be electric type powered with 120v-1 phase.

3.3 CLOSING IN WORK

- A. Cover up or enclose work after it has been properly and completely tested and reviewed.
- B. No additional cost to the Owner will be allowed for uncovering or recovering any work that is covered or enclosed prior to required test and review.

3.4 TEST AND ADJUST

- A. Ductwork shall be leak tested in accordance with Section 15990 "Testing and Balancing Air and Water Systems". Provide end cap and closure pieces. Close off and seal openings in ductwork to be tested. Ductwork shall be tested before it is insulated.
- B. Before operating any system, the system shall be cleaned out to remove dust and foreign materials.
- C. After the installation is complete and ready for operation, test the system under normal operating conditions in the presence of the Architect and demonstrate that the system functions as designed.
- D. Correct defects, which develop during the test period, conduct additional testing until defect free operation is achieved.

3.5 CLEANUP AND CORROSION PREVENTION

- A. Ductwork and equipment shall be thoroughly cleaned. Dirt, dust, and debris shall be removed and the premises left in a clean and neat condition.
- B. Before covering is applied to duct systems, clips, rods, clevises and other hanger attachments, and before uncovered piping is permitted to be concealed, corrosion and rust shall be wire brushed and cleaned and in the case of iron products, a coat of approved protective paint applied to these surfaces.

3.6 INSTRUCTIONS

- A. On completion of the project, instruct the Owner's representative in the care and operation of the system. The total period of instruction shall not exceed four (4) hours. The time of instruction shall be arranged with the Owner. In addition to the prime Mechanical Contractor, the control system Contractor, Balancing Contractor, and Owner's representative shall be present and participate in the Owner's instruction.

3.7 FIRESTOPPING

- A. All penetrations of fire-rated assemblies including walls and floors by mechanical system components (piping, ductwork, conduits, etc.) shall be firestopped as specified.

END OF SECTION

SECTION 15830

HVAC POWER VENTILATORS

PART 1 - GENERAL

1.1 SUMMARY

A. Section Includes:

1. Centrifugal roof ventilators.
2. In-line centrifugal fans.

1.2 ACTION SUBMITTALS

A. Product Data: For each type of product indicated.

B. Shop Drawings: Include plans, elevations, sections, details, and attachments to other work.

1. Detail equipment assemblies and indicate dimensions, weights, loads, required clearances, method of field assembly, components, and location and size of each field connection.
2. Wiring Diagrams: For power, signal, and control wiring.
3. Vibration Isolation Base Details: Detail fabrication including anchorages and attachments to structure and to supported equipment. Include adjustable motor bases, rails, and frames for equipment mounting.
4. Design Calculations: Calculate requirements for selecting vibration isolators and seismic restraints and for designing vibration isolation bases.
5. Delegated design: provide for radon mitigation as noted in spec section 15870, Radon Mitigation.

1.3 CLOSEOUT SUBMITTALS

A. Operation and maintenance data.

1.4 QUALITY ASSURANCE

A. Electrical Components, Devices, and Accessories: Listed and labeled as defined in NFPA 70, by a qualified testing agency, and marked for intended location and application.

B. AMCA Compliance: Fans shall have AMCA-Certified performance ratings and shall bear the AMCA-Certified Ratings Seal.

PART 2 - PRODUCTS

2.1 CENTRIFUGAL ROOF VENTILATORS

- A. Manufacturers: Subject to compliance with requirements, provide products by one of the following:
1. Greenheck Fan Corporation (Basis of Design)
 2. Loren Cook Company
 3. PennBarry
 4. Or Approved Equal
- B. Housing: Removable, spun-aluminum, dome top and outlet baffle or galvanized steel, mushroom-domed top; square, one-piece, aluminum base with venturi inlet cone.
1. Hinged Subbase: Galvanized-steel hinged arrangement permitting service and maintenance.
- C. Fan Wheels: Aluminum hub and wheel with backward-inclined blades.
- D. Belt Drives:
1. Resiliently mounted to housing.
 2. Fan Shaft: Turned, ground, and polished steel; keyed to wheel hub.
 3. Shaft Bearings: Permanently lubricated, permanently sealed, self-aligning ball bearings.
 4. Pulleys: Cast-iron, adjustable-pitch motor pulley.
 5. Fan and motor isolated from exhaust airstream.
- E. Accessories:
1. Variable-Speed Controller: Solid-state control to reduce speed from 100 to less than 50 percent, and used on direct drive units.
 2. Disconnect Switch: Nonfusible type, with thermal-overload protection mounted outside fan housing, factory wired through an internal aluminum conduit.
 3. Bird Screens: Removable, 1/2-inch mesh, aluminum or brass wire.
 4. Dampers: Counterbalanced, parallel-blade, backdraft dampers mounted in curb base; factory set to close when fan stops.
 5. Motorized Dampers: Parallel-blade dampers mounted in curb base with electric actuator; wired to close when fan stops.
- F. Roof Curbs: Galvanized steel; mitered and welded corners; 1-1/2-inch- thick, rigid, fiberglass insulation adhered to inside walls; and 1-1/2-inch wood nailer. Size as required to suit roof opening and fan base.
1. Configuration: Built-in raised cant and mounting flange.
 2. Overall Height: 16 inches.
 3. Sound Curb: Curb with sound-absorbing insulation.
 4. Pitch Mounting: Manufacture curb for roof slope.
 5. Metal Liner: Galvanized steel.

6. Mounting Pedestal: Galvanized steel with removable access panel.
- G. Capacities and Characteristics: Refer to drawings.

2.2 IN-LINE CENTRIFUGAL FANS

- A. Manufacturers: Subject to compliance with requirements, provide products by one of the following:
 1. Greenheck Fan Corporation (Basis of Design)
 2. Loren Cook Company
 3. PennBarry
 4. Or Approved Equal
- B. Housing: Split, spun aluminum with aluminum straightening vanes, inlet and outlet flanges, and support bracket adaptable to floor, side wall, or ceiling mounting.
- C. Direct-Drive Units: Motor mounted in airstream, factory wired to disconnect switch located on outside of fan housing; with wheel, inlet cone, and motor on swing-out service door.
- D. Belt-Driven Units: Motor mounted on adjustable base, with adjustable sheaves, enclosure around belts within fan housing, and lubricating tubes from fan bearings extended to outside of fan housing.
- E. Fan Wheels: Aluminum, airfoil blades welded to aluminum hub.
- F. Accessories:
 1. Variable-Speed Controller: Solid-state control to reduce speed from 100 to less than 50 percent. Direct drive motors only.
 2. Volume-Control Damper: Manually operated with quadrant lock, located in fan outlet.
 3. Companion Flanges: For inlet and outlet duct connections.
 4. Fan Guards: 1/2- by 1-inch mesh of galvanized steel in removable frame. Provide guard for inlet or outlet for units not connected to ductwork.
 5. Motor and Drive Cover (Belt Guard): Epoxy-coated steel.
- G. Capacities and Characteristics: Refer to drawings.

2.3 RADON MITIGATION EXHAUST FAN

- A. Provide radon exhaust fan in compliance with the State of Maine regulations and state code requirements. Contractor shall design and build radon mitigation system as noted on drawing M-801, and guide specifications in section 15870.

2.4 MOTORS

- A. Comply with NEMA designation, temperature rating, service factor, enclosure type, and efficiency requirements for motors specified in Section 15700 "Common Motor Requirements for HVAC Equipment".
 - 1. Motor Sizes: Minimum size as indicated. If not indicated, large enough so driven load will not require motor to operate in service factor range above 1.0.
- B. Enclosure Type: Totally enclosed, fan cooled.

2.5 SOURCE QUALITY CONTROL

- A. Certify sound-power level ratings according to AMCA 301, "Methods for Calculating Fan Sound Ratings from Laboratory Test Data." Factory test fans according to AMCA 300, "Reverberant Room Method for Sound Testing of Fans." Label fans with the AMCA-Certified Ratings Seal.
- B. Certify fan performance ratings, including flow rate, pressure, power, air density, speed of rotation, and efficiency by factory tests according to AMCA 210, "Laboratory Methods of Testing Fans for Aerodynamic Performance Rating." Label fans with the AMCA-Certified Ratings Seal.

PART 3 - EXECUTION

3.1 INSTALLATION

- A. Secure roof-mounted fans to roof curbs with cadmium-plated hardware. See Section 07610 "Metal Roofing" for installation of roof curbs.
- B. Ceiling Units: Suspend units from structure; use steel wire or metal straps.
- C. Support suspended units from structure using threaded steel rods and spring hangers having a static deflection of 1 inch. Vibration-control devices are specified in Section 15070 "Vibration and Seismic Controls for HVAC".
- D. Provide units with clearances for service and maintenance.
- E. Label units according to requirements specified in Section 15000 including "Identification for HVAC Piping and Equipment".

3.2 CONNECTIONS

- A. Drawings indicate general arrangement of ducts and duct accessories. Make final duct connections with flexible connectors. Flexible connectors are specified in Section 15800 "Air Duct and Accessories".
- B. Provide ducts adjacent to power ventilators to allow service and maintenance.

- C. Ground equipment according to Section 16450 "Grounding and Bonding for Electrical Systems".
- D. Connect wiring according to Section 16120 "Low-Voltage Electrical Power Conductors and Cables".

3.3 FIELD QUALITY CONTROL

- A. Perform tests and inspections.
 - 1. Manufacturer's Field Service: Engage a factory-authorized service representative to inspect components, assemblies, and equipment installations, including connections, and to assist in testing.
- B. Tests and Inspections:
 - 1. Verify that shipping, blocking, and bracing are removed.
 - 2. Verify that unit is secure on mountings and supporting devices and that connections to ducts and electrical components are complete. Verify that proper thermal-overload protection is installed in motors, starters, and disconnect switches.
 - 3. Verify that cleaning and adjusting are complete.
 - 4. Disconnect fan drive from motor, verify proper motor rotation direction, and verify fan wheel free rotation and smooth bearing operation. Reconnect fan drive system, align and adjust belts, and install belt guards.
 - 5. Adjust belt tension.
 - 6. Adjust damper linkages for proper damper operation.
 - 7. Verify lubrication for bearings and other moving parts.
 - 8. Verify that manual and automatic volume control and fire and smoke dampers in connected ductwork systems are in fully open position.
 - 9. Disable automatic temperature-control operators, energize motor and adjust fan to indicated rpm, and measure and record motor voltage and amperage.
 - 10. Shut unit down and reconnect automatic temperature-control operators.
 - 11. Remove and replace malfunctioning units and retest as specified above.
- C. Test and adjust controls and safeties. Replace damaged and malfunctioning controls and equipment.
- D. Prepare test and inspection reports.
- E. Prepare and test Radon Mitigation system in compliance with state of Maine code and regulations, as required.

3.4 ADJUSTING

- A. Adjust damper linkages for proper damper operation.
- B. Adjust belt tension.

- C. Comply with requirements in Section 15950 "Testing, Adjusting, and Balancing for HVAC" for testing, adjusting, and balancing procedures.
- D. Replace fan and motor pulleys as required to achieve design airflow.
- E. Lubricate bearings.

END OF SECTION

SECTION 15840

AIR TERMINAL UNITS

PART 1 - GENERAL

1.1 SUMMARY

A. Section Includes:

1. Shutoff, single-duct air terminal units, for VAV and CAV type.
2. Casing liner.

1.2 ACTION SUBMITTALS

A. Product Data: For each type of air terminal unit.

B. Shop Drawings: For air terminal units.

1. Include plans, elevations, sections, and mounting details.
2. Include details of equipment assemblies. Indicate dimensions, weights, loads, required clearances, method of field assembly, components, and location and size of each field connection.
3. Include diagrams for power, signal, and control wiring.
4. Hangers and supports, including methods for duct and building attachment, seismic restraints, and vibration isolation.

C. Delegated-Design Submittal:

1. Materials, fabrication, assembly, and spacing of hangers and supports.
2. Include design calculations, including analysis data signed and sealed by the qualified professional engineer responsible for their preparation for selecting hangers and supports and seismic restraints.

1.3 INFORMATIONAL SUBMITTALS

A. Coordination Drawings: Reflected ceiling plans, drawn to scale, on which the following items are shown and coordinated with each other, using input from installers of the items involved:

B. Field quality-control reports.

1.4 CLOSEOUT SUBMITTALS

A. Operation and maintenance data.

PART 2 - PRODUCTS

2.1 SYSTEM DESCRIPTION

- A. Electrical Components, Devices, and Accessories: Listed and labeled as defined in NFPA 70, by a qualified testing agency, and marked for intended location and application.
- B. ASHRAE Compliance: Applicable requirements in ASHRAE 62.1, Section 5 - "Systems and Equipment" and Section 7 - "Construction and System Start-up."
- C. ASHRAE Compliance: Applicable requirements in ASHRAE/IES 90.1, "Section 6 - Heating, Ventilating, and Air Conditioning."

2.2 SHUTOFF, SINGLE-DUCT AIR TERMINAL UNITS

- A. Manufacturers: Subject to compliance with requirements, provide products by one of the following:
 - 1. Titus (Basis of Design)
 - 2. Anemostat Products; a Mestek Company
 - 3. Krueger
 - 4. Or Approved Equal
- B. Configuration: Volume-damper assembly inside unit casing with control components inside a protective metal shroud.
- C. Casing: 0.034-inch- thick galvanized steel, single wall.
 - 1. Casing Liner: Comply with requirements in "Casing Liner" Article for fibrous-glass or flexible elastomeric duct liner.
 - 2. Air Inlet: Round stub connection or S-slip and drive connections for duct attachment.
 - 3. Air Outlet: S-slip and drive connections, size matching inlet size.
 - 4. Access: Removable panels for access to parts requiring service, adjustment, or maintenance; with airtight gasket.
 - 5. Airstream Surfaces: Surfaces in contact with the airstream shall comply with requirements in ASHRAE 62.1.
- D. Regulator Assembly: System-air-powered bellows section incorporating polypropylene bellows for volume regulation and thermostatic control. Bellows shall operate at temperatures from zero to 140 deg F, shall be impervious to moisture and fungus, shall be suitable for 10-inch wg static pressure, and shall be factory tested for leaks.
- E. Volume Damper: Galvanized steel with peripheral gasket and self-lubricating bearings.

1. Maximum Damper Leakage: AHRI 880 rated, 2 percent of nominal airflow at 3-inch wg inlet static pressure.
 2. Damper Position: Normally open.
- F. Attenuator Section: 0.032-inch aluminum sheet.
1. Attenuator Section Liner: Comply with requirements in "Casing Liner" Article for fibrous-glass duct liner.
 2. Airstream Surfaces: Surfaces in contact with the airstream shall comply with requirements in ASHRAE 62.1.
- G. Hot water reheating Coils: Retain one of first two subparagraphs below.
1. Provide 2-way temperature control valve for hot water controls of each reheat coil
 2. Access door interlocked disconnect switch.
 3. Downstream air temperature sensor with local connection to override discharge-air temperature to not exceed a maximum temperature set point (adjustable). Retain applicable subparagraphs below.
 4. Fan interlock contacts.
- H. Control devices shall be compatible with temperature controls system specified in Section 15920 "Direct Digital Control (DDC) System for HVAC".
1. Electric Damper Actuator: 24 V, powered open, spring return.
 2. Electronic Damper Actuator: 24 V, powered open, spring return.
 3. Electric Thermostat: Wall-mounted electronic type with clock display, temperature display in Fahrenheit and Celsius, and space temperature set point.
 4. Electronic Thermostat: Wall-mounted electronic type with temperature set-point display in Fahrenheit and Celsius.
 5. Electronic Velocity Controller: Factory calibrated and field adjustable to minimum and maximum air volumes; shall maintain constant airflow dictated by thermostat within 5 percent of set point while compensating for inlet static-pressure variations up to 4-inch wg; and shall have a multipoint velocity sensor at air inlet.
 6. Terminal Unit Controller: Pressure-independent, variable-air-volume (VAV) controller with electronic airflow transducer with multipoint velocity sensor at air inlet, factory calibrated to minimum and maximum air volumes, and having the following features:
 - a. Occupied and unoccupied operating mode.
 - b. Remote reset of airflow or temperature set points.
 - c. Adjusting and monitoring with portable terminal.
 - d. Communication with temperature-control system specified in Section 15920 "Direct Digital Control (DDC) System for HVAC".
 7. Room Sensor: Wall mounted with temperature set-point adjustment and access for connection of portable operator terminal.

- I. Controls:
 - 1. Suitable for operation with duct pressures between 0.25- and 3.0-inch wg inlet static pressure.
 - 2. System-powered, wall-mounted thermostat.
- J. Control Sequences:
 - 1. Occupied:
 - a. In a call for cooling, airflow will increase as the damper opens towards maximum setting to satisfy set point.
 - b. In a call for less cooling, airflow will decrease as the damper closes towards minimum setting to satisfy set point.
 - 2. Unoccupied:
 - a. Damper closes to minimum maximum setting.

2.3 CASING LINER

- A. Casing Liner: Fibrous-glass duct liner, complying with ASTM C 1071, NFPA 90A, or NFPA 90B; and with NAIMA AH124, "Fibrous Glass Duct Liner Standard."
 - 1. Minimum Thickness: 3/4 inch.
 - a. Maximum Thermal Conductivity:
 - 1) Type I, Flexible: 0.27 Btu x in./h x sq. ft. x deg F at 75 deg F mean temperature.
 - 2. Antimicrobial Erosion-Resistant Coating: Apply to the surface of the liner that will form the interior surface of the duct to act as a moisture repellent and erosion-resistant coating. Antimicrobial compound shall be tested for efficacy by an NRTL and registered by the EPA for use in HVAC systems.
 - 3. Water-Based Liner Adhesive: Comply with NFPA 90A or NFPA 90B and with ASTM C 916.
 - a. Adhesive VOC Content: 80 g/L or less.
 - b. Adhesive shall comply with the testing and product requirements of the California Department of Public Health's "Standard Method for the Testing and Evaluation of Volatile Organic Chemical Emissions from Indoor Sources Using Environmental Chambers."
- B. Casing Liner: Flexible elastomeric duct liner fabricated of preformed, cellular, closed-cell, sheet materials complying with ASTM C 534, Type II, Grade 1; and with NFPA 90A or NFPA 90B.
 - 1. Minimum Thickness: 3/4 inch.

2. Surface-Burning Characteristics: Maximum flame-spread index of 25 and maximum smoke-developed index of 50 when tested according to UL 723; certified by an NRTL.
3. Liner Adhesive: As recommended by insulation manufacturer and complying with NFPA 90A or NFPA 90B.
 - a. Adhesive VOC Content: 50 g/L or less.
 - b. Adhesive shall comply with the testing and product requirements of the California Department of Public Health's "Standard Method for the Testing and Evaluation of Volatile Organic Chemical Emissions from Indoor Sources Using Environmental Chambers."

2.4 SOUND ATTENUATOR

1. Provide sound attenuator as part of the VAV box assembly. Provide attenuation for obtaining NC level in room of 25 or less.

2.5 SOURCE QUALITY CONTROL

- A. Factory Tests: Test assembled air terminal units according to AHRI 880.
 1. Label each air terminal unit with plan number, nominal airflow, maximum and minimum factory-set airflows, coil type, and AHRI certification seal.

PART 3 - EXECUTION

3.1 HANGER AND SUPPORT INSTALLATION

- A. Comply with SMACNA's "HVAC Duct Construction Standards - Metal and Flexible," Ch. 5, "Hangers and Supports" and with Section 15071 "Hangers and Supports for HVAC Piping and Equipment".
- B. Building Attachments: Concrete inserts, powder-actuated fasteners, or structural-steel fasteners appropriate for construction materials to which hangers are being attached.
 1. Where practical, install concrete inserts before placing concrete.
 2. Install powder-actuated concrete fasteners after concrete is placed and completely cured.
 3. Use powder-actuated concrete fasteners for standard-weight aggregate concretes and for slabs more than 4 inches thick.
 4. Do not use powder-actuated concrete fasteners for lightweight-aggregate concretes and for slabs less than 4 inches thick.
 5. Do not use powder-actuated concrete fasteners for seismic restraints.
- C. Hangers Exposed to View: Threaded rod and angle or channel supports.

- D. Provide upper attachments to structures. Select and size upper attachments with pull-out, tension, and shear capacities appropriate for supported loads and building materials where used.

3.2 SEISMIC-RESTRAINT-DEVICE INSTALLATION

- A. Provide hangers and braces designed to support the air terminal units and to restrain against seismic forces required by applicable building codes. Comply with SMACNA's "Seismic Restraint Manual: Guidelines for Mechanical Systems." Comply with requirements for seismic-restraint devices in Section 15070 "Vibration and Seismic Controls for HVAC".
- B. Select seismic-restraint devices with capacities adequate to carry present and future static and seismic loads.
- C. Provide cables so they do not bend across edges of adjacent equipment or building structure.
- D. Provide cable restraints on air terminal units that are suspended with vibration isolators.
- E. Provide seismic-restraint devices using methods approved by an agency acceptable to authorities having jurisdiction.
- F. Attachment to Structure: If specific attachment is not indicated, anchor bracing and restraints to structure, to flanges of beams, to upper truss chords of bar joists, or to concrete members.
- G. Drilling for and Setting Anchors:
 - 1. Identify position of reinforcing steel and other embedded items before drilling holes for anchors. Do not damage existing reinforcement or embedded items during drilling. Notify Construction Manager if reinforcing steel or other embedded items are encountered during drilling. Locate and avoid prestressed tendons, electrical and telecommunications conduit, and gas lines.
 - 2. Do not drill holes in concrete or masonry until concrete, mortar, or grout has achieved full design strength.
 - 3. Wedge Anchors: Protect threads from damage during anchor installation. Install heavy-duty sleeve anchors with sleeve fully engaged in the structural element to which anchor is to be fastened.
 - 4. Set anchors to manufacturer's recommended torque, using a torque wrench.
 - 5. Install zinc-coated steel anchors for interior applications and stainless-steel anchors for applications exposed to weather.

3.3 TERMINAL UNIT INSTALLATION

- A. Provide air terminal units according to NFPA 90A, "Standard for the Installation of Air Conditioning and Ventilating Systems."

- B. Provide air terminal units level and plumb. Maintain sufficient clearance for normal service and maintenance.
- C. Provide wall-mounted thermostats.
- D. Provide hot water reheat coil and wall thermostat for maintaining room temperature at control setpoint.
- E. Where installing power and control wiring to VAV/ reheat controller adjacent to air terminal unit, allow space for service and maintenance.
- F. Comply with requirements in Section 15800 "Ductwork and Accessories" for connecting ducts to air terminal units.
- G. Make connections to air terminal units with flexible connectors complying with requirements in Section 15800 "Ductwork and Accessories".
- H. Label each air terminal unit with plan number, nominal airflow, and maximum and minimum factory-set airflows. Comply with requirements in Section 15076 "Identification for HVAC Piping and Equipment" for equipment labels and warning signs and labels.

3.4 FIELD QUALITY CONTROL

- A. Perform the following tests and inspections with the assistance of a factory-authorized service representative:
 - 1. After installing air terminal units and after electrical circuitry has been energized, test for compliance with requirements.
 - 2. Leak Test: After installation, fill water coils and test for leaks. Repair leaks and retest until no leaks exist.
 - 3. Operational Test: After electrical circuitry has been energized, start units to confirm proper motor rotation and unit operation.
 - 4. Test and adjust controls and safeties. Replace damaged and malfunctioning controls and equipment.
- B. Air terminal units shall be considered defective if it does not pass tests and inspections.
- C. Prepare test and inspection reports.

3.5 DEMONSTRATION

- A. Engage a factory-authorized service representative to train Owner's maintenance personnel to adjust, operate, and maintain air terminal units.

END OF SECTION

SECTION 15850

DIFFUSERS, REGISTERS, AND GRILLES

PART 1 - GENERAL

1.1 SUMMARY

A. Section Includes:

1. Rectangular and square ceiling diffusers.
2. Fixed face registers and grilles.

B. Related Sections:

1. Section 15800 "Ductwork and Accessories" for fire and smoke dampers and volume-control dampers not integral to diffusers, registers, and grilles.

1.2 ACTION SUBMITTALS

A. Product Data: For each type of product indicated, include the following:

1. Data Sheet: Indicate materials of construction, finish, and mounting details; and performance data including throw and drop, static-pressure drop, and noise ratings.
2. Diffuser, Register, and Grille Schedule: Indicate drawing designation, room location, quantity, model number, size, and accessories furnished.

B. Samples: For each exposed product and for each color and texture specified.

PART 2 - PRODUCTS

2.1 CEILING DIFFUSERS

A. Rectangular and Square Ceiling Diffusers:

1. Manufacturers: Subject to compliance with requirements, provide products by one of the following:
 - a. Titus (Basis of Design)
 - b. Krueger
 - c. Anemostat Products; a Mestek company
 - d. Or Approved Equal
2. Devices shall be specifically designed for variable-air-volume flows.
3. Material: Steel or aluminum, as noted on drawings.
4. Finish: Baked enamel, white.

5. Face Size: As noted on drawings.
6. Face Style: Plaque.
7. Mounting: As noted on drawings.
8. Dampers: None.
9. Accessories:
 - a. Equalizing grid.
 - b. Safety chain.
 - c. Wire guard.
 - d. Sectorizing baffles.
 - e. Operating rod extension.

2.2 REGISTERS AND GRILLES

A. Fixed Face Registers and Grilles for Supply, Return and Exhaust:

1. Manufacturers: Subject to compliance with requirements, provide products by one of the following:
 - a. Titus (Basis of Design)
 - b. Krueger
 - c. Anemostat Products; a Mestek company.
 - d. Or Approved Equal
2. Material: Steel or aluminum, as noted on drawings.
3. Finish: Baked enamel, white, unless otherwise indicated.
4. Face Arrangement: 1/2-by-1/2-by-1/2-inch core.
5. Core Construction: Integral.
6. Rear-Blade Arrangement: Horizontal spaced 3/4 inch apart.
7. Frame: 1-1/4 inches wide.
8. Mounting Frame: As noted on drawings.
9. Mounting: Countersunk concealed screw.
10. Damper Type: None.
11. Accessories:
 - a. Square to round / square to square adaptor.

2.3 SOURCE QUALITY CONTROL

- ### A. Verification of Performance: Rate diffusers, registers, and grilles according to ASHRAE 70, "Method of Testing for Rating the Performance of Air Outlets and Inlets."

PART 3 - EXECUTION

3.1 INSTALLATION

- #### A. Provide diffusers, registers, and grilles level and plumb.

- B. Ceiling-Mounted Outlets and Inlets: Drawings indicate general arrangement of ducts, fittings, and accessories. Air outlet and inlet locations have been indicated to achieve design requirements for air volume, noise criteria, airflow pattern, throw, and pressure drop. Make final locations where indicated, as much as practical. For units installed in lay-in ceiling panels, locate units in the center of panel. Where architectural features or other items conflict with installation, notify Construction Manager for a determination of final location.
- C. Provide diffusers, registers, and grilles with airtight connections to ducts and to allow service and maintenance of dampers, air extractors, and fire dampers.

3.2 ADJUSTING

- A. After installation, adjust diffusers, registers, and grilles to air patterns indicated, or as directed, before starting air balancing.

END OF SECTION

SECTION 15860

BREECHINGS, BOILER STACK, AND CHIMNEY

PART 1 – GENERAL

1.1 SUMMARY

A. Section Includes:

1. Pre-fabricated metal breechings and boiler stack.
2. Guying and bracing materials for boiler stack.

B. Related Requirements:

1. Division 4, Masonry, General for Chimney construction

1.2 ACTION SUBMITTALS

A. Product Data: For each type of product, supports, and accessories.

B. Shop Drawings: For breechings and vertical stack.

1. Provide shop drawing plans, elevations, sections, and attachment details.
2. Include details of equipment assemblies. Indicate dimensions, weights, loads, required clearances, method of field assembly, components, and location and size of each field connection.
3. Detail fabrication and assembly of hangers and seismic restraints.

1.3 INFORMATIONAL SUBMITTALS

A. Welding certificates.

B. Seismic Qualification Certificates: For factory-fabricated breeching, accessories, and components from manufacturer.

C. Sample Warranty: For special 5 year warranty.

1.4 QUALITY ASSURANCE

A. Welding Qualifications: Qualify procedures and personnel according to the following:

1. AWS D1.1/D1.1M, "Structural Welding Code - Steel," for hangers and supports.

2. AWS D9.1/D9.1M, "Sheet Metal Welding Code," for shop and field welding of joints and seams in breechings.
- B. Certified Sizing Calculations: Manufacturer shall certify venting system sizing calculations.

PART 2 - PRODUCTS

2.1 FABRICATED METAL BREECHINGS

- A. Fabricate breechings from ASTM A 1011/A 1011M, double wall round sheet metal ducts including stainless inner wall (16-inch, inner diameter, I.D.), and aluminized steel outer wall (18 inch, O.D) complying with NFPA 211 for minimum metal thickness.
- B.
1. Up to 1.764 Sq. Ft. (0.164 Sq. m.) or 18 Inches (457 mm) in Diameter: 0.093 inch (2.36 mm): Inner diameter.
 2. Larger Than 1.764 Sq. Ft. (0.164 Sq. m.) or 18 Inches (457 mm) in Diameter: 0.123 inch (3.12 mm): outer diameter.
- C. Fabricate cleanout doors from compatible material, same thickness as breeching, bolted and gasketed.
- D. Provide double walled connections, either flanged or slip on as required by manufacturer's recommendations.
- E. Breeching/ boiler exhaust single-wall ductwork in the boiler room shall be insulated with 1-inch minimum ceramic fiber insulation for personnel protection.
- F. The vertical double-walled stack in the chimney is not required to be insulated: provide a minimum of 1" air gap.
- G. Refer to architectural drawings for coordination chimney construction.

2.2 GUYING AND BRACING OF STACK: MATERIALS

- A. Angle Iron: minimum of three galvanized steel, 2 by 2 by 0.25 inch (50 by 50 by 6 mm) on roof as required.

PART 3 - EXECUTION

3.1 INSTALLATION OF UNLISTED, FIELD-FABRICATED BREECHINGS

- A. Install breechings on propane boilers, and manifold as indicated on the drawings.
- B. Suspend breechings independent of their appliance connections.

- C. Install seismic restrains according to manufacturer's written instructions. Comply with requirements in Section 15070 "Vibration and Seismic Controls for HVAC."
- D. Align breechings at connections, with smooth internal surface and a maximum 1/8-inch (3-mm) misalignment tolerance.
- E. Slope breechings down in direction of appliance, with condensate drain connection at lowest point piped to nearest drain.
- F. Lap joints in direction of flow.
- G. Support the stack inside the chimney with stainless steel angle supports as indicated on the drawings. Supports for the Stack below grade shall be exposed and accessible from inside the chimney for maintenance and initial and future inspections. The first stack support below grade is the anchor for supporting the entire stack. The 2nd stack support above grade is a guide/ support.
- H. Support breechings from building structure with bolts, concrete inserts, steel expansion anchors, welded studs, or beam clamps with restraints. Supports for breechings shall be able to withstand any seismic events without collapsing or falling onto the floor.
- I. Clean breechings internally, during and after installation, to remove dust and debris. Clean external surfaces to remove welding slag and mill film. Grind welds smooth and apply touchup finish to match factory or shop finish.
- J. After completing system installation, remove burrs, dirt, and construction debris, and repair damaged finishes.
- K. Provide temporary closures at ends of breechings that are not completed or connected to equipment.
- L. Provide condensate drain line for bottom of stack and route to nearest floor or trench drain.

END OF SECTION

SECTION 15870

RADON MITIGATION

PART 1 – GENERAL

1.1 SECTION REQUIREMENTS

- A. System Description: Radon mitigation work as per the following specifications.
- B. System shall be a sub-slab depressurization system.

1.2 WARRANTY

- A. Contractor shall provide Design/Build services for Radon Mitigation, including design of the entire Radon mitigation system, sizing and selection of fan(s), testing equipment and monitoring and total installation in accordance with Federal EPA, and the state of Maine EPA regulations and requirements. Contractor shall guarantee that this installation shall maintain average radon levels, based upon long-term Alpha-Track testing, at below the EPA Action Level of 4.0 pCi/L for a period of 10 years, subject to the terms of this contract.
- B. If, at any time during this Warranty period, the results of approved, long-term Alpha-Track radon tests are above 4.0 pCi/L, the Contractor shall take appropriate and necessary steps, and at no cost to the Client, to lower average, long-term radon levels to below 4.0 pCi/L.
- C. Provide long-term Alpha-Track testing shall be performed by the Client and in accordance with ANSI/AARST MAMF 2010.
- D. With the exception of the exhaust fan units, the Contractor shall repair or replace any defective mechanical or electrical components in the system, at no cost to the Client, for a period of 10 years, beginning at the time of initial system activation.
- E. Includes a 5-year, replacement warranty on exhaust fan units, beginning at the time of initial activation with any related work and materials provided at no cost to the Client.
- F. All warranties and guaranties are extended to future owners of same property.

1.3 QUALITY ASSURANCE

- A. Work includes the use of continuous electronic radon monitors (CRM) to determine the initial effectiveness of the systems installed, and monitor initial system performance as well as be able to adjust the systems in as timely a manner as required.

- B. CRM testing shall be used to determine that initial post-mitigation, short-term average radon levels are below the Environmental Protection Agency (EPA) Action Level of 4.0 pCi/L in each building. Contractor shall require access to the ground floor building to conduct post-mitigation testing, with required notice given the tenants.

1.4 POST-MITIGATION TESTING

- A. Contractor shall provide short-term radon detectors for independent short-term post mitigation testing, and also provide instruction to owner to assist with sampling.
- B. Short-term radon testing shall be conducted in each lowest level of the mitigated building. The building shall be sampled for a minimum of 48 hours and not exceeding a maximum of 96 hours. Short-term testing will be conducted using activated charcoal (AC) detectors.
- C. Contractor shall manage the radon detector distribution, analysis and reporting their services and will rely on owner personnel to deploy and retrieve the detectors at each property and ship the samples to laboratory.
- D. Notify MTA that “closed-house” conditions must be established twelve (12) hours prior to the start of testing and maintained for the full duration of testing. Closed-house conditions require that all windows be closed and doors only be used for personnel entry and egress. Provide the number of entry/egress points to be minimized during the testing period. Doors should not be propped open for an extended period of time. Closed-house conditions allow normal use of HVAC systems. Use of exhaust fans should also be minimized during the test period.
- E. All detectors must be left untouched and undisturbed during the testing period. Project Management should note any evidence of disturbance or tampering associated with sampling equipment or sampling conditions and make appropriate recommendations.
- F. Per EPA, provide and perform long-term, post-mitigation testing using Alpha-Track test devices. Provide post-mitigation testing and shall be performed in accordance with ANSI/AARST MAMF 2010.
- G. Contractor shall coordinate with MTA for test requirements and procedures before actual tests are conducted, and schedules for the tests.

1.5 REPORT

- A. A letter report will be prepared. For the post-mitigation samples, the final report will summarize the protocols used to collect the samples, and present the analytical results. The report will include description of sample locations.

PART 2 - PRODUCTS

2.1 EXHAUST FANS

- A. Typical fan specifications: each fan shall require a minimum of ¼ horsepower motor, 60 hz, 115 V, 2.0 amps. Refer to drawings for additional information on the proposed fan, and back-up fan and piping layout.
- B. Fan units are inline duct style and are ENERGY STAR approved whenever possible.
- C. Provide an additional, or a second fan as a back-up.
- D. Fans utilized shall be for the given purpose, and shall be installed to minimize projected noise in the building. Unless otherwise specified, additional sound reduction measures shall be included in the design and installation.
- E. Additional sound reduction measures such as, but not limited to, exhaust mufflers and vibration/sound dampeners, insulation of piping system running through the building if required shall be installed at no additional cost to the Client.

2.2 VENT PIPE

- A. All piping shall be sealed air-tight venting (per EPA). ALL vent piping shall be round, Schedule-80, plastic pipe.
- B. Venting terminus shall be a minimum of 3-ft ABOVE the roof line for proper exhausting of high radon levels. Provide double elbows at the terminal point above the roof to minimize any rain intrusion.
- C. Unless otherwise noted, all interior pipe to be exposed, and in chases shall be insulated for sound attenuation.
- D. All exterior plastic vent piping shall be coated with (primer) paint, as required.

PART 3 - EXECUTION

3.1 RADON MITIGATION

- A. Install mitigation systems to address radon entry.
- B. Radon mitigation system shall include installing one (1) exhaust fans, as noted on the drawing to adequately address the entire building, as required. The fan shall be installed in the attic space. Fan status indication shall be included with the fan starter panel. The second fan shall be a back-up fan. The second fan shall be stored loose for future installation, as required.

- C. Systems to be vented via the attic space of building to above the roof line.
- D. Continuously running electric exhaust fan shall be mounted within the attic space of the building, with exit stacks routed through the roof above to the open air, per EPA standards.

END OF SECTION

SECTION 15890

HVAC WATER TREATMENT

PART 1 - GENERAL

1.1 SUMMARY

A. Section includes the following HVAC water-treatment systems:

1. Manual and automatic chemical-feed equipment and controls.
2. Ozone-generator biocide equipment and controls.
3. Chemical treatment test equipment.
4. Chemicals.
5. HVAC makeup-water softeners for boiler and hydronic heating water system
6. Water filtration equipment.

1.2 ACTION SUBMITTALS

A. Product Data: Include rated capacities, operating characteristics, and furnished specialties and accessories for each type of product.

1.3 INFORMATIONAL SUBMITTALS

A. Field quality-control reports.

B. Including but not limited to the following:

1. Pumps
2. Chemical Solutions
3. Control devices
4. Test equipment
5. Tanks

1.4 CLOSEOUT SUBMITTALS

A. Operation and maintenance data.

PART 2 - PRODUCTS

2.1 PERFORMANCE REQUIREMENTS

A. Closed hydronic systems shall have the following water qualities:

1. pH: Maintain a value within 9.0 to 10.5.
2. "P" Alkalinity: Maintain a value within 100 to 500 ppm.

3. Boron: Maintain a value within 100 to 200 ppm.
4. Chemical Oxygen Demand: Maintain a maximum value of 100 ppm.
5. Soluble Copper: Maintain a maximum value of 0.20 ppm.
6. TSS: Maintain a maximum value of 10 ppm.
7. Ammonia: Maintain a maximum value of 20 ppm.
8. Free Caustic Alkalinity: Maintain a maximum value of 20ppm.
9. Microbiological Limits:
 - a. Total Aerobic Plate Count: Maintain a maximum value of 1000 organisms/mL.
 - b. Total Anaerobic Plate Count: Maintain a maximum value of 100 organisms/mL.
 - c. Nitrate Reducers: Maintain a maximum value of 100 organisms/mL.
 - d. Sulfate Reducers: Maintain a maximum value of zero organisms/mL.
 - e. Iron Bacteria: Maintain a maximum value of zero organisms/mL.

2.2 MANUAL CHEMICAL-FEED EQUIPMENT

- A. Bypass Feeders: Steel, with corrosion-resistant exterior coating, minimum 3-1/2-inch (89-mm) fill opening in the top, and NPS 3/4 (DN 20) bottom inlet and top side outlet. Quarter turn or threaded fill cap with gasket seal and diaphragm to lock the top on the feeder when exposed to system pressure in the vessel.
 1. Capacity: 5 gal. (19 L).
 2. Minimum Working Pressure: 175 psig (1210 kPa).

2.3 AUTOMATIC CHEMICAL-FEED EQUIPMENT

- A. Water Meter:
 1. AWWA C700, oscillating-piston, magnetic-drive, totalization meter.
 2. Body: Bronze.
 3. Minimum Working-Pressure Rating: 150 psig (1035 kPa).
 4. Maximum Pressure Loss at Design Flow: 3 psig (20 kPa).
 5. Registration: Gallons (Liters) or cubic feet (cubic meters).
 6. End Connections: Threaded.
 7. Controls: Flow-control switch with normally open contacts; rated for maximum 10 A, 250-V ac, and that will close at adjustable increments of total flow.
- B. Inhibitor Injection Timers:
 1. Microprocessor-based controller with digital display in NEMA 250, Type 12 enclosure with gasketed and lockable door. Interface for start/stop and status indication at central workstation as described in Section 15920 "Direct Digital Control (DDC) System for HVAC."
 2. Programmable timers with infinite adjustment over full range, and mounted in cabinet with hand-off-auto switches and status lights.
 3. Test switch.
 4. Hand-off-auto switch for chemical pump.

5. Illuminated legend to indicate feed when pump is activated.
6. Programmable lockout timer with indicator light. Lockout timer to deactivate the pump and activate alarm circuits.
7. Digital display makeup totalizer to measure amount of makeup and bleed-off water from two water meter inputs.

C. pH Controller:

1. Microprocessor-based controller, 1 percent accuracy in a range from zero to 14 units. Incorporate solid-state integrated circuits and digital display in NEMA 250, Type 12 enclosure with gasketed and lockable door. Interface for start/stop and status indication at central workstation as described in Section 15920 "Direct Digital Control (DDC) System for HVAC."
2. Digital display and touch pad for input.
3. Sensor probe adaptable to sample stream manifold.
4. High, low, and normal pH indication.
5. High or low-pH-alarm-light trip points, field adjustable; with silence switch.
6. Hand-off-auto switch for acid pump.
7. Internal adjustable hysteresis or deadband.

D. TSS Controller:

1. Microprocessor-based controller, 1 percent accuracy in a range from zero to 5000 micromhos. Incorporate solid-state integrated circuits and digital display in NEMA 250, Type 12 enclosure with gasketed and lockable door. Interface for start/stop and status indication at central workstation as described in Section 15920 "Direct Digital Control (DDC) System for HVAC."
2. Digital display and touch pad for input.
3. Sensor probe adaptable to sample stream manifold.
4. High, low, and normal conductance indication.
5. High- or low-conductance-alarm-light trip points, field adjustable; with silence switch.
6. Hand-off-auto switch for solenoid bleed-off valve.
7. Bleed-off valve activated indication.
8. Internal adjustable hysteresis or deadband.
9. Bleed Valves:
 - a. Hot Water Boilers: Motorized ball valve, copper or stainless steel body, and TFE seats and seals.

E. Biocide Feeder Timer:

1. Microprocessor-based controller with digital display in NEMA 250, Type 12 enclosure with gasketed and lockable door. Interface for start/stop and status indication at central workstation as described in Section 15920 "Direct Digital Control (DDC) System for HVAC."
2. 24-hour timer with 14-day skip feature to permit activation any hour of day.
3. Precision, solid-state, bleed-off lockout timer and clock-controlled biocide pump timer. Prebleed and bleed lockout timers.
4. Solid-state alternator to enable use of two formulations.

5. 24-hour display of time of day.
6. 14-day display of day of week.
7. Battery backup so clock is not disturbed by power outages.
8. Hand-off-auto switches for biocide pumps.
9. Biocide A and Biocide B pump running indication.

F. Chemical Solution Tanks:

1. Chemical-resistant reservoirs fabricated from high-density opaque polyethylene with minimum 110 percent containment vessel.
2. Molded cover with recess for mounting pump.
3. Capacity: minimum of 50 gal. (189 L).

G. Chemical Solution Injection Pumps:

1. Self-priming, positive displacement; rated for intended chemical with minimum 25 percent safety factor for design pressure and temperature.
2. Adjustable flow rate.
3. Metal and thermoplastic construction.
4. Built-in relief valve.
5. Fully enclosed, continuous-duty, single-phase motor. Comply with requirements in Section 15700 "Common Motor Requirements for HVAC Equipment."
 - a. Electrical Components, Devices, and Accessories: Listed and labeled as defined in NFPA 70, by a qualified testing agency, and marked for intended location and application.

H. Chemical Solution Tubing: Polyethylene tubing with compression fittings and joints except ASTM A 269, Type 304, stainless steel for steam boiler injection assemblies.

I. Injection Assembly:

1. Quill: Minimum NPS 1/2 (DN 15) with insertion length sufficient to discharge into at least 25 percent of pipe diameter.
2. Ball Valve: **Two**-piece stainless steel, as described in "Stainless-Steel Pipes and Fittings" Article; selected to fit quill.
3. Packing Gland: Mechanical seal on quill of sufficient length to allow quill removal during system operation.
4. Assembly Pressure/Temperature Rating: Minimum 600 psig (4137 kPa) at 200 deg F (93 deg C).

2.4 CHEMICALS

A. Chemicals shall be as recommended by water-treatment system manufacturer that are compatible with piping system components and connected equipment and that can attain water quality specified in "Performance Requirements" Article.

B. Water Softener Chemicals:

1. Mineral: High-capacity, sulfonated-polystyrene ion-exchange resin that is stable over entire pH range with good resistance to bead fracture from attrition or shock. Resin exchange capacity minimum 30,000 grains/cu. ft. (69 kg/cu. m) of calcium carbonate of resin when regenerated with 15 lb (6.8 kg) of salt.
2. Salt for Brine Tanks: High-purity sodium chloride, free of dirt and foreign material. Rock and granulated forms are unacceptable.

PART 3 - EXECUTION

3.1 WATER ANALYSIS

- A. Perform an analysis of supply water to determine quality of water available at Project site.

3.2 INSTALLATION

- A. Install chemical application equipment on concrete bases level and plumb. Maintain manufacturer's recommended clearances. Arrange units so controls and devices that require servicing are accessible. Anchor chemical tanks and floor-mounting accessories to substrate.
- B. Install seismic restraints for equipment and floor-mounting accessories and anchor to building structure. See Section 15070 "Vibration and Seismic Controls for HVAC" for seismic restraints.
- C. Install interconnecting control wiring for chemical treatment controls and sensors.
- D. Provide alarms for fault alarms, low chemicals level, pump status and signals to be sent to the BMS for monitoring.
- E. Mount sensors and injectors in piping circuits.
- F. Bypass Feeders: Install in closed hydronic, hot water systems, including and equipped with the following:
 1. Install bypass feeder in a bypass circuit around circulating pumps unless otherwise indicated on Drawings.
 2. Install water meter in makeup-water supply.
 3. Install test-coupon assembly in bypass circuit around circulating pumps unless otherwise indicated on Drawings.
 4. Install a gate or full-port ball isolation valves on inlet, outlet, and drain below feeder inlet.
 5. Install a swing check on inlet after the isolation valve.
- G. Piping installation requirements are specified in other Sections. Drawings indicate general arrangement of piping, fittings, and specialties.

- H. Where installing piping adjacent to equipment, allow space for service and maintenance.
- I. Make piping connections between HVAC water-treatment equipment and dissimilar-metal piping with dielectric fittings. Dielectric fittings are specified in Section 15180 "Hydronic Piping."
- J. Install shutoff valves on HVAC water-treatment equipment inlet and outlet. Metal general-duty valves are specified in Section 15110 "Ball Valves for HVAC Piping,".
- K. See Section 15400 Plumbing, "Domestic Water Piping Specialties" for backflow preventers required in makeup-water connections to potable-water systems.
- L. Confirm applicable electrical requirements in electrical Sections for connecting electrical equipment.
- M. Ground equipment according to Section 16450 "Grounding and Bonding for Electrical Systems."
- N. Connect wiring according to Section 16120 "Low-Voltage Electrical Power Conductors and Cables."

3.3 FIELD QUALITY CONTROL

- A. Perform the following tests and inspections with the assistance of a factory-authorized service representative:
 - 1. Inspect field-assembled components and equipment installation, including piping and electrical connections.
 - 2. Inspect piping and equipment to determine that systems and equipment have been cleaned, flushed, and filled with water, and are fully operational before introducing chemicals for water-treatment system.
 - 3. Place HVAC water-treatment system into operation and calibrate controls during the preliminary phase of HVAC system's startup procedures.
 - 4. Do not enclose, cover, or put piping into operation until it is tested and satisfactory test results are achieved.
 - 5. Test for leaks and defects. If testing is performed in segments, submit separate report for each test, complete with diagram of portion of piping tested.
 - 6. Leave uncovered and unconcealed new, altered, extended, and replaced water piping until it has been tested and approved. Expose work that has been covered or concealed before it has been tested and approved.
 - 7. Cap and subject piping to static water pressure of 50 psig (345 kPa) above operating pressure, without exceeding pressure rating of piping system materials. Isolate test source and allow test pressure to stand for four hours. Leaks and loss in test pressure constitute defects.
 - 8. Repair leaks and defects with new materials and retest piping until no leaks exist.
- B. Equipment will be considered defective if it does not pass tests and inspections.
- C. Prepare test and inspection reports.

3.4 DEMONSTRATION

- A. Train Owner's maintenance personnel to adjust, operate, and maintain HVAC water-treatment systems and equipment.

END OF SECTION

SECTION 15920DIRECT DIGITAL CONTROL (DDC) SYSTEM FOR HVAC

PART 1 - GENERAL

1.1 SUMMARY

A. Section Includes:

1. DDC system for monitoring and controlling of HVAC systems.
2. Delivery of selected control devices to equipment and systems manufacturers for factory installation and to HVAC systems installers for field installation.

B. Related Requirements:

1. Section 15990 "Sequence of Operations for HVAC Controls" for control sequences in DDC systems.

1.2 DEFINITIONS

A. Algorithm: A logical procedure for solving a recurrent mathematical problem. A prescribed set of well-defined rules or processes for solving a problem in a finite number of steps.

B. Analog: A continuously varying signal value, such as current, flow, pressure, or temperature.

C. BACnet Specific Definitions:

1. BACnet: Building Automation Control Network Protocol, ASHRAE 135. A communications protocol allowing devices to communicate data over and services over a network.
2. BACnet Interoperability Building Blocks (BIBBs): BIBB defines a small portion of BACnet functionality that is needed to perform a particular task. BIBBs are combined to build the BACnet functional requirements for a device.
3. BACnet/IP: Defines and allows using a reserved UDP socket to transmit BACnet messages over IP networks. A BACnet/IP network is a collection of one or more IP subnetworks that share the same BACnet network number.
4. BACnet Testing Laboratories (BTL): Organization responsible for testing products for compliance with ASHRAE 135, operated under direction of BACnet International.
5. PICS (Protocol Implementation Conformance Statement): Written document that identifies the particular options specified by BACnet that are implemented in a device.

D. Binary: Two-state signal where a high signal level represents ON" or "OPEN" condition and a low signal level represents "OFF" or "CLOSED" condition. "Digital" is sometimes used interchangeably with "Binary" to indicate a two-state signal.

- E. Controller: Generic term for any standalone, microprocessor-based, digital controller residing on a network, used for local or global control. Three types of controllers are indicated: Network Controller, Programmable Application Controller, and Application-Specific Controller.
- F. Control System Integrator: An entity that assists in expansion of existing enterprise system and support of additional operator interfaces to I/O being added to existing enterprise system.
- G. CAV: Constant Air Volume.
- H. COV: Changes of value.
- I. DDC System Provider: Authorized representative of, and trained by, DDC system manufacturer and responsible for execution of DDC system Work indicated.
- J. Distributed Control: Processing of system data is decentralized and control decisions are made at subsystem level. System operational programs and information are provided to remote subsystems and status is reported back. On loss of communication, subsystems shall be capable of operating in a standalone mode using the last best available data.
- K. DOCSIS: Data-Over Cable Service Interface Specifications.
- L. Gateway: Bidirectional protocol translator that connects control systems that use different communication protocols.
- M. HLC: Heavy load conditions.
- N. I/O: System through which information is received and transmitted. I/O refers to analog input (AI), binary input (BI), analog output (AO) and binary output (BO). Analog signals are continuous and represent control influences such as flow, level, moisture, pressure, and temperature. Binary signals convert electronic signals to digital pulses (values) and generally represent two-position operating and alarm status. "Digital," (DI and (DO), is sometimes used interchangeably with "Binary," (BI) and (BO), respectively.
- O. LAN: Local area network.
- P. LNS: LonWorks Network Services.
- Q. LON Specific Definitions:
 - 1. FTT-10: Echelon Transmitter-Free Topology Transceiver.
 - 2. LonMark: Association comprising suppliers and installers of LonTalk products. Association provides guidelines for implementing LonTalk protocol to ensure interoperability through a standard or consistent implementation.
 - 3. LonTalk: An open standard protocol developed by the Echelon Corporation that uses a "Neuron Chip" for communication. LonTalk is a register trademark of Echelon.
 - 4. LonWorks: Network technology developed by Echelon.

5. Node: Device that communicates using CEA-709.1-C protocol and that is connected to a CEA-709.1-C network.
 6. Node Address: The logical address of a node on the network, consisting of a Domain number, Subnet number, and Node number. "Node number" portion of an address is a number assigned to device during installation, is unique within a subnet, and is not a factory-set unique Node ID.
 7. Node ID: A unique 48-bit identifier assigned at factory to each CEA-709.1-C device. Sometimes called a "Neuron ID."
 8. Program ID: An identifier (number) stored in a device (usually EEPROM) that identifies node manufacturer, functionality of device (application and sequence), transceiver used, and intended device usage.
 9. Standard Configuration Property Type (SCPT): Pronounced "skip-it." A standard format type maintained by LonMark International for configuration properties.
 10. Standard Network Variable Type (SNVT): Pronounced "snivet." A standard format type maintained by LonMark used to define data information transmitted and received by individual nodes. "SNVT" is used in two ways. It is an acronym for "Standard Network Variable Type" and is often used to indicate a network variable itself (i.e., it can mean "a network variable of a standard network variable type").
 11. Subnet: Consists of a logical grouping of up to 127 nodes, where logical grouping is defined by node addressing. Each subnet is assigned a number, which is unique within a Domain. See "Node Address."
 12. TP/FT-10: Free Topology Twisted Pair network defined by CEA-709.3 and is most common media type for a CEA-709.1-C control network.
 13. TP/XF-1250: High-speed, 1.25-Mbps, twisted-pair, doubly terminated bus network defined by "LonMark Interoperability Guidelines" typically used only to connect multiple TP/FT-10 networks.
 14. User-Defined Configuration Property Type (UCPT): Pronounced "U-Keep-It." A Configuration Property format type that is defined by device manufacturer.
 15. User-Defined Network Variable Type (UNVT): Network variable format defined by device manufacturer. UNVTs create non-standard communications that other vendors' devices may not correctly interpret and may negatively impact system operation. UNVTs are not allowed.
- R. Low Voltage: As defined in NFPA 70 for circuits and equipment operating at less than 50 V or for remote-control, signaling power-limited circuits.
- S. Modbus TCP/IP: An open protocol for exchange of process data.
- T. MS/TP: Master-slave/token-passing, IEE 8802-3. Datalink protocol LAN option that uses twisted-pair wire for low-speed communication.
- U. Network Controller: Digital controller, which supports a family of programmable application controllers and application-specific controllers, that communicates on peer-to-peer network for transmission of global data.
- V. Network Repeater: Device that receives data packet from one network and rebroadcasts it to another network. No routing information is added to protocol.
- W. PDA: Personal digital assistant.

- X. Peer to Peer: Networking architecture that treats all network stations as equal partners.
- Y. POT: Portable operator's terminal.
- Z. RAM: Random access memory.
- AA. RF: Radio frequency.
- BB. Router: Device connecting two or more networks at network layer.
- CC. TCP/IP: Transport control protocol/Internet protocol incorporated into Microsoft Windows.
- DD. UPS: Uninterruptible power supply.
- EE. USB: Universal Serial Bus.
- FF. User Datagram Protocol (UDP): This protocol assumes that the IP is used as the underlying protocol.
- GG. VAV: Variable air volume.
- HH. WLED: White light emitting diode.

1.3 PREINSTALLATION MEETINGS

- A. Preinstallation Conference: Conduct conference at Project site.

1.4 ACTION SUBMITTALS

- A. Product Data: For each type of product include the following:
 1. Construction details, material descriptions, dimensions of individual components and profiles, and finishes.
 2. Operating characteristics, electrical characteristics, and furnished accessories indicating process operating range, accuracy over range, control signal over range, default control signal with loss of power, calibration data specific to each unique application, electrical power requirements, and limitations of ambient operating environment, including temperature and humidity.
 3. Product description with complete technical data, performance curves, and product specification sheets.
 4. Installation, operation and maintenance instructions including factors effecting performance.
 5. Bill of materials of indicating quantity, manufacturer, and extended model number for each unique product.
 - a. Operator workstations.
 - b. Servers.
 - c. Printers.

- d. Gateways.
 - e. Routers.
 - f. Protocol analyzers.
 - g. DDC controllers.
 - h. Enclosures.
 - i. Electrical power devices.
 - j. UPS units.
 - k. Accessories.
 - l. Instruments.
 - m. Control dampers and actuators.
 - n. Control valves and actuators.
6. When manufacturer's product datasheets apply to a product series rather than a specific product model, clearly indicate and highlight only applicable information.
 7. Each submitted piece of product literature shall clearly cross reference specification and drawings that submittal is to cover.
- B. Software Submittal:
1. Cross-referenced listing of software to be loaded on each operator workstation, server, gateway and DDC controller.
 2. Description and technical data of all software provided, and cross-referenced to products in which software will be installed.
 3. Operating system software, operator interface and programming software, color graphic software, DDC controller software, maintenance management software, and third-party software.
 4. Include a flow diagram and an outline of each subroutine that indicates each program variable name and units of measure.
 5. Listing and description of each engineering equation used with reference source.
 6. Listing and description of each constant used in engineering equations and a reference source to prove origin of each constant.
 7. Description of operator interface to alphanumeric and graphic programming.
 8. Description of each network communication protocol.
 9. Description of system database, including all data included in database, database capacity and limitations to expand database.
 10. Description of each application program and device drivers to be generated, including specific information on data acquisition and control strategies showing their relationship to system timing, speed, processing burden and system throughout.
 11. Controlled Systems: Instrumentation list with element name, type of device, manufacturer, model number, and product data. Include written description of sequence of operation including schematic diagram.
- C. Shop Drawings:
1. Include plans, elevations, sections, and mounting details where applicable.
 2. Include details of product assemblies. Indicate dimensions, weights, loads, required clearances, method of field assembly, components, and location and size of each field connection.

3. Detail means of vibration isolation and show attachments to rotating equipment.
4. Plan Drawings indicating the following:
 - a. Screened backgrounds of walls, structural grid lines, HVAC equipment, ductwork and piping.
 - b. Room names and numbers with coordinated placement to avoid interference with control products indicated.
 - c. Each laptop, server, gateway, router, DDC controller, control panel instrument connecting to DDC controller, and damper and valve connecting to DDC controller, if included in Project. The laptop shall be able to connect at various points in the DDC system for access to all control points.
 - d. Exact placement of products in rooms, ducts, and piping to reflect proposed installed condition.
 - e. Network communication cable and raceway routing.
 - f. Information, drawn to scale.
 - g. Proposed routing of wiring, cabling, conduit, and tubing, coordinated with building services for review before installation.
5. Schematic drawings for each controlled HVAC system indicating the following:
 - a. I/O points labeled with point names shown. Indicate instrument range, normal operating set points, and alarm set points. Indicate fail position of each damper and valve, if included in Project.
 - b. I/O listed in table format showing point name, type of device, manufacturer, model number, and cross-reference to product data sheet number.
 - c. A graphic showing location of control I/O in proper relationship to HVAC system.
 - d. Wiring diagram with each I/O point having a unique identification and indicating labels for all wiring terminals.
 - e. Unique identification of each I/O that shall be consistently used between different drawings showing same point.
 - f. Elementary wiring diagrams of controls for HVAC equipment motor circuits including interlocks, switches, relays and interface to DDC controllers.
 - g. Narrative sequence of operation.
 - h. Graphic sequence of operation, showing all inputs and output logical blocks.
6. Control panel drawings indicating the following:
 - a. Panel dimensions, materials, size, and location of field cable, raceways, and tubing connections.
 - b. Interior subpanel layout, drawn to scale and showing all internal components, cabling and wiring raceways, nameplates and allocated spare space.
 - c. Front, rear, and side elevations and nameplate legend.
 - d. Unique drawing for each panel.
7. DDC system network riser diagram indicating the following:

- a. Each device connected to network with unique identification for each.
 - b. Interconnection of each different network in DDC system.
 - c. For each network, indicate communication protocol, speed and physical means of interconnecting network devices, such as copper cable type, or fiber-optic cable type. Indicate raceway type and size for each.
 - d. Each network port for connection of an operator workstation or other type of operator interface with unique identification for each.
8. DDC system electrical power riser diagram indicating the following:
- a. Each point of connection to field power with requirements (volts/phase/hertz/amperes/connection type) listed for each.
 - b. Each control power supply including, as applicable, transformers, power-line conditioners, transient voltage suppression and high filter noise units, DC power supplies, and UPS units with unique identification for each.
 - c. Each product requiring power with requirements (volts/phase/hertz/amperes/connection type) listed for each.
 - d. Power wiring type and size, race type, and size for each.
9. Monitoring and control signal diagrams indicating the following:
- a. Control signal cable and wiring between controllers and I/O.
 - b. Point-to-point schematic wiring diagrams for each product.
 - c. Control signal tubing to sensors, switches and transmitters.
 - d. Process signal tubing to sensors, switches and transmitters.
10. Color graphics indicating the following:
- a. Itemized list of color graphic displays to be provided.
 - b. For each display screen to be provided, a true color copy showing layout of pictures, graphics and data displayed.
 - c. Intended operator access between related hierarchical display screens.
- D. System Description:
1. Full description of DDC system architecture, network configuration, operator interfaces and peripherals, servers, controller types and applications, gateways, routers and other network devices, and power supplies.
 2. Complete listing and description of each report, log and trend for format and timing and events which initiate generation.
 3. System and product operation under each potential failure condition including, but not limited to, the following:
 - a. Loss of power.
 - b. Loss of network communication signal.
 - c. Loss of controller signals to inputs and outpoints.
 - d. Operator workstation failure.
 - e. Gateway failure.
 - f. Network failure
 - g. Controller failure.

- h. Instrument failure.
 - i. Control damper and valve actuator failure.
4. Complete bibliography of documentation and media to be delivered to Owner.
 5. Description of testing plans and procedures.
 6. Description of Owner training.
- E. Samples:
1. For each exposed product, installed in finished space for approval of selection of aesthetic characteristics.
- F. Delegated-Design Submittal: For DDC system products and installation indicated as being delegated.
1. Supporting documentation showing DDC system design complies with performance requirements indicated, including calculations and other documentation necessary to prove compliance.
 2. Schedule and design calculations for control dampers and actuators.
 - a. Flow at Project design and minimum flow conditions.
 - b. Face velocity at Project design and minimum airflow conditions.
 - c. Pressure drop across damper at Project design and minimum airflow conditions.
 - d. AMCA 500-D damper installation arrangement used to calculate and schedule pressure drop, as applicable to installation.
 - e. Maximum close-off pressure.
 - f. Leakage airflow at maximum system pressure differential (fan close-off pressure).
 - g. Torque required at worst case condition for sizing actuator.
 - h. Actuator selection indicating torque provided.
 - i. Actuator signal to control damper (on, close or modulate).
 - j. Actuator position on loss of power.
 - k. Actuator position on loss of control signal.
 3. Schedule and design calculations for control valves and actuators.
 - a. Flow at Project design and minimum flow conditions.
 - b. Pressure-differential drop across valve at Project design flow condition.
 - c. Maximum system pressure-differential drop (pump close-off pressure) across valve at Project minimum flow condition.
 - d. Design and minimum control valve coefficient with corresponding valve position.
 - e. Maximum close-off pressure.
 - f. Leakage flow at maximum system pressure differential.
 - g. Torque required at worst case condition for sizing actuator.
 - h. Actuator selection indicating torque provided.
 - i. Actuator signal to control damper (on, close or modulate).
 - j. Actuator position on loss of power.
 - k. Actuator position on loss of control signal.

4. Schedule and design calculations for selecting flow instruments.
 - a. Instrument flow range.
 - b. Project design and minimum flow conditions with corresponding accuracy, control signal to transmitter and output signal for remote control.
 - c. Extreme points of extended flow range with corresponding accuracy, control signal to transmitter and output signal for remote control.
 - d. Pressure-differential loss across instrument at Project design flow conditions.
 - e. Where flow sensors are mated with pressure transmitters, provide information for each instrument separately and as an operating pair.

1.5 INFORMATIONAL SUBMITTALS

- A. Coordination Drawings: Plan drawings, reflected ceiling plan(s), and other details, drawn to scale and coordinated with each other, using input from installers of the items involved.
- B. Qualification Data:
 1. Systems Provider Qualification Data:
 - a. Resume of project manager assigned to Project.
 - b. Resumes of application engineering staff assigned to Project.
 - c. Resumes of installation and programming technicians assigned to Project.
 - d. Resumes of service technicians assigned to Project.
 - e. Brief description of past project including physical address, floor area, number of floors, building system cooling and heating capacity and building's primary function.
 - f. Description of past project DDC system, noting similarities to Project scope and complexity indicated.
 - g. Names of staff assigned to past project that will also be assigned to execute work of this Project.
 - h. Owner contact information for past project including name, phone number, and e-mail address.
 - i. Contractor contact information for past project including name, phone number, and e-mail address.
 - j. Engineer contact information for past project including name, phone number, and e-mail address.
 2. Manufacturer's qualification data.
 3. Testing agency's qualifications data.
- C. Welding certificates.
- D. Product Certificates:
 1. Data Communications Protocol Certificates: Certifying that each proposed DDC system component complies with ASHRAE 135.

2. Data Communications Protocol Certificates: Certifying that each proposed DDC system component complies with LonWorks.

- E. Product Test Reports: For each product that requires testing to be performed by manufacturer and witnessed by a qualified testing agency, or a qualified testing agency.
- F. Preconstruction Test Reports: For each separate test performed.
- G. Source quality-control reports.
- H. Field quality-control reports.
- I. Sample Warranty: For manufacturer's warranty.

1.6 CLOSEOUT SUBMITTALS

- A. Operation and Maintenance Data: For DDC system to include in emergency, operation and maintenance manuals.
 - 1. In addition to items specified in Section 15000 "Supplemental General Mechanical Requirements," include the following:
 - a. Project Record Drawings of as-built versions of submittal Shop Drawings provided in electronic PDF format.
 - b. Testing and commissioning reports and checklists of completed final versions of reports, checklists, and trend logs.
 - c. As-built versions of submittal Product Data.
 - d. Names, addresses, e-mail addresses and 24-hour telephone numbers of Installer and service representatives for DDC system and products.
 - e. Operator's manual with procedures for operating control systems including logging on and off, handling alarms, producing point reports, trending data, overriding computer control and changing set points and variables.
 - f. Programming manuals with description of programming language and syntax, of statements for algorithms and calculations used, of point database creation and modification, of program creation and modification, and of editor use.
 - g. Engineering, installation, and maintenance manuals that explain how to:
 - 1) Design and install new points, panels, and other hardware.
 - 2) Perform preventive maintenance and calibration.
 - 3) Debug hardware problems.
 - 4) Repair or replace hardware.
 - h. Documentation of all programs created using custom programming language including set points, tuning parameters, and object database.
 - i. Backup copy of graphic files, programs, and database on electronic media such as DVDs.
 - j. List of recommended spare parts with part numbers and suppliers.

- k. Complete original-issue documentation, installation, and maintenance information for furnished third-party hardware including computer equipment and sensors.
- l. Complete original-issue copies of furnished software, including operating systems, custom programming language, operator workstation software, and graphics software.
- m. Licenses, guarantees, and warranty documents.
- n. Recommended preventive maintenance procedures for system components, including schedule of tasks such as inspection, cleaning, and calibration; time between tasks; and task descriptions.
- o. Owner training materials.

1.7 MAINTENANCE MATERIAL SUBMITTALS

- A. Furnish extra materials and parts that match products installed and that are packaged with protective covering for storage and identified with labels describing contents.
- B. Include product manufacturers' recommended parts lists for proper product operation over four-year period following warranty period. Parts list shall be indicated for each year.
- C. Furnish parts, as indicated by manufacturer's recommended parts list, for product operation during two-year period following warranty period.
- D. Furnish quantity indicated of matching product(s) in Project inventory for each unique size and type of following:
 - 1. Network Controller: One.
 - 2. Programmable Application Controller: two.
 - 3. Application-Specific Controller: two, minimum.
 - 4. Room Carbon Dioxide Sensor and Transmitter: One
 - 5. Room Temperature Sensor and Transmitter]: as noted.
 - 6. General-Purpose Relay: as required.
 - 7. Multifunction Time-Delay Relay: as required.
 - 8. Current-Sensing Relay: as required.
 - 9. Combination On-Off Status Sensor and On-Off Relay: as required
 - 10. Transformer: as required.
 - 11. DC Power Supply: as required.
 - 12. Supply of 50 percent spare fiber-optic cable splice organizer cabinets for several re-terminations.

1.8 QUALITY ASSURANCE

- A. DDC System Manufacturer Qualifications:
 - 1. Nationally recognized manufacturer of DDC systems and products.
 - 2. DDC systems with similar requirements to those indicated for a continuous period of 10 years within time of bid.

3. DDC systems and products that have been successfully tested and in use on at least five past projects.
4. Having complete published catalog literature, installation, operation and maintenance manuals for all products intended for use.
5. Having full-time in-house employees for the following:
 - a. Product research and development.
 - b. Product and application engineering.
 - c. Product manufacturing, testing and quality control.
 - d. Technical support for DDC system installation training, commissioning and troubleshooting of installations.
 - e. Owner operator training.

B. DDC System Provider Qualifications:

1. Authorized representative of, and trained by, DDC system manufacturer.
2. In-place facility located within 25 miles of Project.
3. Demonstrated past experience with installation of DDC system products being installed for period within five consecutive years before time of bid.
4. Demonstrated past experience on five projects of similar complexity, scope and value.
5. Each person assigned to Project shall have demonstrated past experience.
6. Staffing resources of competent and experienced full-time employees that are assigned to execute work according to schedule.
7. Service and maintenance staff assigned to support Project during warranty period.
8. Product parts inventory to support on-going DDC system operation for a period of not less than 5 years after Substantial Completion.
9. DDC system manufacturer's backing to take over execution of Work if necessary to comply with requirements indicated. Include Project-specific written letter, signed by manufacturer's corporate officer, if requested.

C. Testing Agency Qualifications: Member company of NETA or an NRTL.

1. Testing Agency's Field Supervisor: Certified by NETA to supervise on-site testing.

D. Welding Qualifications: Qualify procedures and personnel according to the following:

1. AWS D1.1/D1.1M, "Structural Welding Code - Steel."
2. AWS D1.2/D1.2M, "Structural Welding Code - Aluminum."
3. AWS D1.3/D1.3M, "Structural Welding Code - Sheet Steel."
4. AWS D1.4/D1.4M, "Structural Welding Code - Reinforcing Steel."

E. Pipe and Pressure-Vessel Welding Qualifications: Qualify procedures and operators according to ASME Boiler and Pressure Vessel Code.

1.9 PRECONSTRUCTION TESTING

- A. Preconstruction Testing Service: Engage a qualified testing agency to perform preconstruction testing on field mockups.

1. Include test assemblies representative of proposed materials and construction.
 2. Build mockup at testing agency facility using personnel, materials, and methods of construction that will be used at Project site.
 3. Notify Engineer 5 days in advance of dates and times of tests.
- B. Preconstruction Testing: Performed by a qualified testing agency on manufacturer's standard assemblies.

1.10 WARRANTY

- A. Manufacturer's Warranty: Manufacturer and Installer agree to repair or replace products that fail in materials or workmanship within specified warranty period.
1. Failures shall be adjusted, repaired, or replaced at no additional cost or reduction in service to Owner.
 2. Include updates or upgrades to software and firmware if necessary to resolve deficiencies.
 - a. Install updates only after receiving Owner's written authorization.
 3. Warranty service shall occur during normal business hours and commence within 24 hours of Owner's warranty service request.
 4. Warranty Period: Two year(s) from date of Substantial Completion.
 - a. For Gateway: Three-year parts and labor warranty for each.

PART 2 - PRODUCTS

2.1 MANUFACTURERS

- A. Following may be considered:
1. Siemens
 2. Tridium
 3. Honeywell

2.2 DDC SYSTEM DESCRIPTION

- A. Microprocessor-based monitoring and control including analog/digital conversion and program logic. A control loop or subsystem in which digital and analog information is received and processed by a microprocessor, and digital control signals are generated based on control algorithms and transmitted to field devices to achieve a set of predefined conditions.
1. DDC system shall consist of a high-speed, peer-to-peer network of distributed DDC controllers, other network devices, operator interfaces, and software.

- B. Electrical Components, Devices, and Accessories: Listed and labeled as defined in NFPA 70, by a qualified testing agency, and marked for intended location and application.

2.3 WEB ACCESS

- A. DDC system shall be Web based, or Web compatible

- 1. Web-Based Access to DDC System:

- a. DDC system software shall be based on server thin-client architecture, designed around open standards of Web technology. DDC system server shall be accessed using a Web browser over DDC system network, using Owner's LAN, and remotely over Internet.
- b. Intent of thin-client architecture is to provide operators complete access to DDC system via a Web browser. No special software other than a Web browser shall be required to access graphics, point displays, and trends; to configure trends, points, and controllers; and to edit programming.
- c. Web access shall be password protected.

- 2. Web-Compatible Access to DDC System:

- a. Portable laptop computer or, server shall perform overall system supervision and configuration, graphical user interface, management report generation, and alarm annunciation.
- b. DDC system shall support Web browser access to building data. Operator using a standard Web browser shall be able to access control graphics and change adjustable set points.
- c. Web access shall be password protected.

2.4 PERFORMANCE REQUIREMENTS

- A. Delegated Design: Engage a qualified professional to design DDC system to satisfy requirements indicated.

- 1. System Performance Objectives:

- a. DDC system shall manage HVAC systems.
- b. DDC system control shall operate HVAC systems to achieve optimum operating costs while using least possible energy and maintaining specified performance.
- c. DDC system shall respond to power failures, HVAC equipment failures, and adverse and emergency conditions encountered through connected I/O points.
- d. DDC system shall operate while unattended by an operator and through operator interaction.
- e. DDC system shall record trends and transaction of events and produce report information such as performance, energy, occupancies, and equipment operation.

- B. Surface-Burning Characteristics: Products installed in ducts, equipment, and return-air paths shall comply with ASTM E 84; testing by a qualified testing agency. Identify products with appropriate markings of applicable testing agency.
1. Flame-Spread Index: 25 or less.
 2. Smoke-Developed Index: 50 or less.
- C. DDC System Speed:
1. Response Time of Connected I/O:
 - a. AI point values connected to DDC system shall be updated at least every 5 seconds for use by DDC controllers. Points used globally shall also comply with this requirement.
 - b. BI point values connected to DDC system shall be updated at least every 5 seconds for use by DDC controllers. Points used globally shall also comply with this requirement.
 - c. AO points connected to DDC system shall begin to respond to controller output commands within 2 second(s). Global commands shall also comply with this requirement.
 - d. BO point values connected to DDC system shall respond to controller output commands within 2 second(s). Global commands shall also comply with this requirement.
 2. Display of Connected I/O:
 - a. Analog point COV connected to DDC system shall be updated and displayed at least every 5 seconds for use by operator.
 - b. Binary point COV connected to DDC system shall be updated and displayed at least every 5 seconds for use by operator.
 - c. Alarms of analog and digital points connected to DDC system shall be displayed within 30 seconds of activation or change of state.
 - d. Graphic display refresh shall update within 5 seconds.
 - e. Point change of values and alarms displayed from workstation to workstation when multiple operators are viewing from multiple workstations shall not exceed graphic refresh rate indicated.
- D. Network Bandwidth: Design each network of DDC system to include at least 30 percent available spare bandwidth with DDC system operating under normal and heavy load conditions indicated. Calculate bandwidth usage, and apply a safety factor to ensure that requirement is satisfied when subjected to testing under worst case conditions.
- E. DDC System Data Storage:
1. Include server(s) with disk drive data storage to archive not less than 24 consecutive months of historical data for all I/O points connected to system, including alarms, event histories, transaction logs, trends and other information indicated.

2. When logged onto a server, operator shall be able to also interact with any DDC controller connected to DDC system as required for functional operation of DDC system.
3. Server(s) shall be used for application configuration; for archiving, reporting and trending of data; for operator transaction archiving and reporting; for network information management; for alarm annunciation; and for operator interface tasks and controls application management.
4. Server(s) shall use IT industry-standard database platforms such as Microsoft SQL Server and Microsoft Data Engine (MSDE).

F. Future Expandability:

1. DDC system size shall be expandable to an ultimate capacity of at least 2 times total I/O points indicated.
2. Additional DDC controllers, I/O and associated wiring shall be all that is needed to achieve ultimate capacity. Initial network infrastructure shall be designed and installed to support ultimate capacity.
3. Operator interfaces installed initially shall not require hardware and software additions and revisions for ultimate capacity.

G. Input Point Displayed Accuracy: Input point displayed values shall meet following end-to-end overall system accuracy, including errors associated with meter, sensor, transmitter, lead wire or cable, and analog to digital conversion.

1. Flow:
 - a. Air: Within 5 percent of design flow rate.
 - b. Air (Terminal Units): Within 5 percent of design flow rate.
 - c. Water: Within 5 percent of design flow rat
2. Gas:
 - a. Carbon Dioxide: Within 50 ppm.
 - b. Carbon Monoxide: Within 5 percent of reading.
 - c. Oxygen: Within 5 percent of reading.
 - d. Refrigerant: Within 50 ppm.
3. Moisture (Relative Humidity):
 - a. Air: Within 5
 - b. Space: Within 5percent RH.
 - c. Outdoor: Within 5 percent RH.
4. Level: Within 5 percent of reading.
5. Pressure:
 - a. Air, Ducts and Equipment: 1 percent of instrument range.
 - b. Space: Within 1 percent of instrument range.
 - c. Water: Within 1 percent of instrument range.
6. Speed: Within 5 percent of reading.

7. Temperature, Dew Point:
 - a. Air: Within 1 deg F
 - b. Space: Within 1 deg F.
 - c. Outdoor: Within 2 deg F (1 deg C).
 8. Temperature, Dry Bulb:
 - a. Air: Within 1 deg F (0.5 deg C).
 - b. Space: Within 1 deg F (0.5 deg C).
 - c. Outdoor: Within 2 deg F (1 deg C).
 - d. Heating Hot Water: Within 1 deg F (0.5 deg C).
 - e. Temperature Difference: Within 0.25 deg F (0.15 deg C)
 9. Vibration: Within 5 percent of reading.
- H. Precision of I/O Reported Values: Values reported in database and displayed shall have following precision:
1. Current:
 - a. Milliamperes: Nearest 1/100th of a milliampere.
 - b. Amperes: Nearest 1/10th of an ampere up to 100 A; nearest ampere for 100 A and more.
 2. Flow:
 - a. Air: Nearest 1/10th of a cfm through 100 cfm; nearest cfm between 100 and 1000 cfm; nearest 10 cfm between 1000 and 10,000 cfm; nearest 100 cfm above 10,000 cfm.
 - b. Water: Nearest 1/10th gpm through 100 gpm; nearest gpm between 100 and 1000 gpm;
 3. Gas:
 - a. Carbon Dioxide (ppm): Nearest ppm.
 - b. Carbon Monoxide (ppm): Nearest ppm.
 - c. Oxygen (Percentage): Nearest 1/10th of 1 percent.
 - d. Refrigerant (ppm): Nearest ppm.
 4. Moisture (Relative Humidity):
 - a. Relative Humidity (Percentage): Nearest 1 percent.
 5. Level: Nearest 1/100th of an inch through 10 inches, nearest 1/10 of an inch between 10 and 100 inches, nearest inch above 100 inches (Nearest 1/100th of a mm through 10 mm, nearest 1/10th of a mm between 10 and 100 mm, nearest mm above 100 mm).
 6. Speed:
 - a. Rotation (rpm): Nearest 1 rpm.

- b. Velocity: Nearest 1/10th fpm through 100 fpm; nearest fpm between 100 and 1000 fpm; nearest 10 fpm above 1000 fpm (Nearest 1/100th of a M/s through 10 M/s; nearest 1/10th of a M/s above 10 M/s).
 - 7. Position, Dampers and Valves (Percentage Open): Nearest 1 percent.
 - 8. Pressure:
 - a. Air, Ducts and Equipment: Nearest 1/10th in. w.c. (Nearest Pa up to 1000 Pa, nearest 10 Pa above 1000 Pa).
 - b. Space: Nearest 1/100th in. w.c. (Nearest 1/10th Pa)
 - c. Water: Nearest 1/10 psig through 100 psig, nearest psig above 100 psig (Nearest kPa through 1000 kPa, nearest 10 kPa above 1000 kPa).
 - d. Propane pressures: In building, gaseous propane pressures shall be 4 “ to 27” WG, nearest 1” WG.
 - 9. Temperature:
 - a. Air, Ducts and Equipment: Nearest 1/10th of a degree.
 - b. Outdoor: Nearest degree.
 - c. Space: Nearest 1/10th of a degree.
 - d. Heating Hot Water: Nearest degree.
 - 10. Vibration: Nearest 1/10th in/s (Nearest 1/10th mm/s).
 - 11. Voltage: Nearest 1/10 volt up to 100 V; nearest volt above 100 V.
- I. Control Stability: Control variables indicated within the following limits:
- 1. Flow:
 - a. Air, Ducts and Equipment, except Terminal Units: Within 2 percent of design flow rate.
 - b. Air, Terminal Units: Within 5 percent of design flow rate.
 - c. Water: Within 2 percent of design flow rate.
 - 2. Gas:
 - a. Carbon Dioxide: Within 50 ppm.
 - b. Carbon Monoxide: Within 5 percent of reading.
 - c. Oxygen: Within 5 percent of reading.
 - 3. Moisture (Relative Humidity):
 - a. Air: Within 2 percent RH.
 - b. Space: Within 2 percent RH.
 - c. Outdoor: Within 2 percent RH.
 - 4. Level: Within 5 percent of reading.
 - 5. Pressure:

- a. Air, Ducts and Equipment: 0.5percent of instrument range
 - b. Space: Within1 percent of instrument range
 - c. Water: Within 1 percent of instrument range
6. Temperature, Dew Point:
- a. Air: Within 1 deg F (0.5 deg C)
 - b. Space: Within 1 deg F (0.5 deg C)
7. Temperature, Dry Bulb:
- a. Air: Within 1 deg F
 - b. Space: Within 1 deg F (0.5 deg C).
 - c. Heating Hot Water: Within 1 deg F (0.5 deg C).
8. Temperature, Wet Bulb:
- a. Air: Within 1 deg F (0.5 deg C).
 - b. Space: Within 1 deg F (0.5 deg C).
- J. Environmental Conditions for Controllers, Gateways, and Routers:
1. Products shall operate without performance degradation under ambient environmental temperature, pressure and humidity conditions encountered for installed location.
 - a. If product alone cannot comply with requirement, install product in a protective enclosure that is isolated and protected from conditions impacting performance. Enclosure shall be internally insulated, electrically heated, cooled and ventilated as required by product and application.
 2. Products shall be protected with enclosures satisfying the following minimum requirements unless more stringent requirements are indicated. Products not available with integral enclosures complying with requirements indicated shall be housed in protective secondary enclosures. Installed location shall dictate the following NEMA 250 enclosure requirements:
 - a. Outdoors, Protected: NEMA 3. Refer to electrical drawings for additional information.
 - b. Indoors, Heated with Filtered Ventilation:
 - c. Indoors, Heated with Non-Filtered Ventilation:
 - d. Indoors, Heated and Air Conditioned:
 - e. Mechanical Equipment Rooms:
 - 1) Boiler Rooms: NEMA 2 or 3
 - 2) Air-Moving Equipment Room: NEMA 2 or 3

- K. Environmental Conditions for Instruments and Actuators:

1. Instruments and actuators shall operate without performance degradation under the ambient environmental temperature, pressure, humidity, and vibration conditions specified and encountered for installed location.
 - a. If instruments and actuators alone cannot comply with requirement, install instruments and actuators in protective enclosures that are isolated and protected from conditions impacting performance. Enclosure shall be internally insulated, electrically heated, and ventilated as required by instrument and application.
2. Instruments, actuators and accessories shall be protected with enclosures satisfying the following minimum requirements unless more stringent requirements are indicated. Instruments and actuators not available with integral enclosures complying with requirements indicated shall be housed in protective secondary enclosures. Installed location shall dictate the following NEMA 250 enclosure requirements:
 - a. Outdoors, Protected:
 - b. Outdoors, Unprotected Indoors, Heated with Filtered Ventilation: Indoors, Heated with Non-Filtered Ventilation: Indoors, Heated and Air-conditioned: Mechanical Equipment Rooms:
 - 1) Boiler Rooms:
 - 2) Air-Moving Equipment Rooms:

L. Electric Power Quality:

1. Power-Line Surges:
 - a. Protect susceptible DDC system products connected to ac power circuits from power-line surges to comply with requirements of IEEE C62.41.
 - b. Do not use fuses for surge protection.
 - c. Test protection in the normal mode and in the common mode, using the following two waveforms:
 - 1) 10-by-1000-mic.sec. waveform with a peak voltage of 1500 V and a peak current of 60 A.
 - 2) 8-by-20-mic.sec. waveform with a peak voltage of 1000 V and a peak current of 500 A.
2. Power Conditioning:
 - a. Protect susceptible DDC system products connected to ac power circuits from irregularities and noise rejection. Characteristics of power-line conditioner shall be as follows:
 - 1) At 85 percent load, output voltage shall not deviate by more than plus or minus 1 percent of nominal when input voltage fluctuates between minus 20 percent to plus 10 percent of nominal.
 - 2) During load changes from zero to full load, output voltage shall not deviate by more than plus or minus 3 percent of nominal.

- 3) Accomplish full correction of load switching disturbances within five cycles, and 95 percent correction within two cycles of onset of disturbance.
 - 4) Total harmonic distortion shall not exceed 3-1/2 percent at full load.
3. Ground Fault: Protect products from ground fault by providing suitable grounding. Products shall not fail due to ground fault condition.

M. Backup Power Source:

1. HVAC systems and equipment served by a backup power source shall have associated DDC system products that control such systems and equipment also served from a backup power source.

N. UPS:

1. DDC system products powered by UPS units shall include the following:
 - a. Desktop operator workstations.
 - b. Printers.
 - c. Servers.
 - d. Gateways.
 - e. DDC controllers, except application-specific controllers.
2. DDC system instruments and actuators powered by UPS units, or other back-up power source shall include the following:
 - a. Instruments associated with the following systems controlled by DDC system:
 - b. Dampers and actuators associated with the following systems controlled by DDC system
 - c. Valves and actuators associated with the following systems controlled by DDC system:

O. Continuity of Operation after Electric Power Interruption:

1. Equipment and associated factory-installed controls, field-installed controls, electrical equipment, and power supply connected to building normal and backup power systems shall automatically return equipment and associated controls to operating state occurring immediately before loss of normal power, without need for manual intervention by operator when power is restored either through backup power source or through normal power if restored before backup power is brought online.

2.5 SYSTEM ARCHITECTURE

- A. System architecture shall consist of no more than three levels of LANs.

1. Level one LAN shall connect network controllers and operator workstations.
2. Level 1 or 2 LAN shall connect programmable application controllers to other programmable application controllers, and to network controllers.
3. Level 2 or 3 LAN shall connect application-specific controllers to programmable application controllers and network controllers.
4. Level 2 or 3 LAN shall connect application-specific controllers to application-specific controllers.

B. Minimum Data Transfer and Communication Speed:

1. LAN Connecting Operator Workstations and Network Controller: 150 Mbps.
2. LAN Connecting Programmable Application Controllers: 1000 kbps.
3. LAN Connecting Application-Specific Controllers: 115,000 bps.

C. DDC system shall consist of dedicated and separated LANs that are not shared with other building systems and tenant data and communication networks.

D. System architecture shall be modular and have inherent ability to expand to not less than a minimum of two times system size indicated with no impact to performance indicated.

E. System architecture shall perform modifications without having to remove and replace existing network equipment.

F. Number of LANs and associated communication shall be transparent to operator. All I/O points residing on any LAN shall be capable of global sharing between all system LANs.

G. System design shall eliminate dependence on any single device for system alarm reporting and control execution. Each controller shall operate independently by performing its' own control, alarm management and historical data collection.

H. Special Network Architecture Requirements:

1. Air-Handling Systems: For control applications of an air-handling system that consists of air-handling unit(s) and VAV terminal units, include a dedicated LAN of application-specific controllers serving VAV terminal units connected directly to controller that is controlling air-handling system air-handling unit(s). Basically, create a DDC system LAN that aligns with air-handling system being controlled.

2.6 DDC SYSTEM OPERATOR INTERFACES

A. Operator Means of System Access: Operator shall be able to access entire DDC system through any of multiple means, including, but not limited to, the following:

1. Desktop and portable operator workstation with hardwired connection through LAN port.
2. Portable operator terminal with hardwired connection through LAN port.
3. Portable operator workstation with wireless connection through LAN router.
4. PDA with wireless connection through LAN router.

5. Remote connection using outside of system personal computer or PDA through Web access.
 6. Remote connection using portable operator workstation and telephone dial-up modem.
- B. Access to system, regardless of operator means used, shall be transparent to operator.
- C. Network Ports: For hardwired connection of desktop or portable operator workstation. Network port shall be easily accessible, properly protected, clearly labeled, and installed at the following locations:
1. Each mechanical equipment room.
 2. Each boiler room.
 3. Each different roof level with roof-mounted air-handling units.
 4. Security system command center.
 5. Fire-alarm system command center.
- D. Portable Workstations:
1. Connect to DDC system Level one LAN through a communications port directly on LAN or through a communications port on a DDC controller.
 2. Able to communicate with any device located on any DDC system LAN.
 3. Connect to DDC system Level 2 or 3 LAN through a communications port on an application-specific controller, or a room temperature sensor connected to an application-specific controller.
 4. Connect to system through a wireless router connected to Level one LAN.
 5. Portable workstation shall be able to communicate with any device connected to any system LAN regardless of point of physical connection to system.
 6. Monitor, program, schedule, adjust set points, and report capabilities of I/O connected anywhere in system.
 7. Have dynamic graphic displays that are identical to desktop workstations.
- E. POT:
1. Connect DDC controller through a communications port local to controller.
 2. Able to communicate with any DDC system controller that is directly connected **or with** LAN, or connected to DDC system.
- F. Personal Digital Assistant:
1. Connect to system through a wireless router connected to LAN.
 2. Able to communicate with any DDC controller connected to DDC system.
- G. Telephone Communications:
1. Through use of a standard modem, operator shall be able to communicate with any device connected to any system LAN.
 2. Have auto-dial and auto-answer communications to allow desktop and portable workstations and DDC controllers to communicate with remote workstations and remote DDC controllers via telephone lines.

a. Desktop and Portable Operator Workstation Computers with Modems:

- 1) Operators shall be able to perform all control functions, report functions, and database generation and modification functions as if directly connected to system LAN.
- 2) Have routines to automatically answer calls, and either file or display information sent remotely.
- 3) Communications taking place over telephone lines shall be completely transparent to operator.
- 4) Dial-up program shall maintain a user-definable cross-reference and associated telephone numbers so it is not required to remember or manually dial telephone numbers.

b. DDC Controllers:

- 1) Not have modems unless specifically indicated for a unique controller.
- 2) Controllers with modems shall automatically place calls to report critical alarms, or to upload trend and historical information for archiving.
- 3) Analyze and prioritize alarms to minimize initiation of calls.
- 4) Buffer noncritical alarms in memory and report them as a group of alarms, or until an operator manually requests an upload.
- 5) Make provisions for handling busy signals, no-answers, and incomplete data transfers.
- 6) Call default devices when communications cannot be established with primary devices.

H. Critical Alarm Reporting:

1. Operator-selected critical alarms shall be sent by DDC system to notify operator of critical alarms that require immediate attention.
2. DDC system shall send alarm notification to multiple recipients that are assigned for each alarm.
3. DDC system shall notify recipients by any or all means, including e-mail, text message, and prerecorded phone message to mobile and landline phone numbers.

I. Simultaneous Operator Use: Capable of accommodating up to 10 simultaneous operators that are accessing DDC system through any one of operator interfaces indicated.

2.7 NETWORKS

A. Acceptable networks for connecting operator workstations and network, application, and specific controllers include the following:

1. CEA-709.1-C.
2. IP.
3. IEEE 8802-3, Ethernet.

4. MS/TP

2.8 NETWORK COMMUNICATION PROTOCOL

- A. Network communication protocol(s) used throughout entire DDC system shall be open to public and available to other companies for use in making future modifications to DDC system.
- B. ASHRAE 135 Protocol:
1. ASHRAE 135 communication protocol (BACnet) shall be sole and native protocol used throughout entire DDC system.
 2. DDC system shall not require use of gateways except to integrate HVAC equipment and other building systems and equipment, not required to use ASHRAE 135 communication protocol.
 3. If used, gateways shall connect to DDC system using ASHRAE 135 communication protocol and Project object properties and read/write services indicated by interoperability schedule.
 4. Operator workstations, controllers and other network devices shall be tested and listed by BACnet Testing Laboratories.
- C. CEA-709.1-C Protocol:
1. DDC system shall be an open implementation of LonWorks technology using CEA 709.1-C communication protocol and using LonMark SNVTs as defined in LonMark SNVT list exclusively for communication throughout DDC system.
 2. LNS shall be used for all network management including addressing and binding of network variables.
 - a. Final LNS database shall be submitted with Project closeout submittals.
 - b. All devices shall be online and commissioned into LNS database.
 3. All devices connected to DDC system network(s) shall use CEA-709.1-C protocol and be installed so SCPT output from any node on network can be bound to any other node in the domain.
- D. Industry Standard Protocols:
1. DDC system shall use any one or a combination of the following industry standard protocols for network communication while complying with other DDC system requirements indicated:
 - a. ASHRAE 135.
 - b. CEA-709.1-C.
 - c. Modbus Application Protocol Specification V1.1b.
 2. Operator workstations [and network controllers shall communicate through ASHRAE 135 or CEA-709.1-C protocol.

3. Portions of DDC system networks using ASHRAE 135 communication protocol shall be an open implementation of network devices complying with ASHRAE 135. Network devices shall be tested and listed by BACnet Testing Laboratories.
4. Portions of DDC system networks using CEA-709.1-C communication protocol shall be an open implementation of LonWorks technology using CEA-709.1-C communication protocol and using LonMark SNVTs as defined in LonMark SNVT list exclusively for DDC system.
5. Portions of DDC system networks using Modbus Application Protocol Specification V1.1b communication protocol shall be an open implementation of network devices and technology complying with Modbus Application Protocol Specification V1.1b.
6. Gateways shall be used to connect networks and network devices using different protocols.

2.9 PORTABLE OPERATOR WORKSTATIONS

A. Performance Requirements:

1. Performance requirements may dictate equipment exceeding minimum requirements indicated.
2. Energy Star compliant.
3. Hardware and software shall support local down-loading to DDC controllers.
4. Data transfer rate to DDC controller shall be at network speed.

B. Processor:

1. Minimum Processor Speed: 1.0 GHZ.
2. RAM:
 - a. Capacity: minimum of 8 GB.
 - b. Speed and Type: 1600 MHz,
3. Hard Drive:
 - a. Number of Hard Drives: One.
 - b. Capacity: 1 TB
 - c. Minimum Average Seek Time:
 - d. Cache Buffer Size:
4. Video Card: of RAM.

C. Input and Output Ports:

1. Serial port.
2. Shared port for external keyboard or mouse.
3. Four USB 2.0 ports.

4. Ethernet port.
5. IEEE 1394 integrated port.
6. Serial infrared communications port.

D. Battery:

1. 9-cell, 81 Wh lithium ion battery and ac adapter.
2. Battery life of at least three years.
3. Battery charge time of less than three hours.
4. Spare Battery(ies). One.

E. Keyboard:

1. 85-key backlit keyboard.
2. Full upper- and lowercase ASCII keyset.

F. Integral Pointing Device: Touchpad with two buttons or equivalent pointing device.

G. Display:

1. 15.6 diagonal or larger high-definition WLED color display.
2. Antiglare screen.
3. 1920 by 1080 pixel resolution.
4. Brightness: 300 nits.

H. Network Interface Card: Include card with connection, as application.

1. 10-100-1000 base TX Ethernet with RJ45 connector port.
2. 100 base FX Ethernet with SC or ST port.

I. Digital Video Disc Rewrite Recorder (DVD+/-RW):

1. Compatible with DVD disks and data, audio, recordable and rewritable compact disks.
2. 160-ms access time.

J. Accessories:

1. Leather carrying case.
2. Docking station.
3. Wireless-N communication card.
4. Bluetooth module with 2.1 standard technologies.
5. Mobile broadband card.
6. Wireless optical mouse.
7. Cable with network jackets on each end. Minimum cable length shall be <Insert length>.

2.10 POT

- A. Description: Handheld device with integral keypad or touch screen operator interface.
- B. Display: Multiple lines of text display for use in operator interaction with DDC system.
- C. Cable: Flexible coiling cable, at least 36 inches (900 mm) long, with a plug-in jack for connection to DDC controllers, network ports or instruments with an integral LAN port. As an alternative to hardwired connection, POT shall be accessible to DDC controllers through a wireless network connection.
- D. POT shall be powered through network connection.
- E. Connection of POT to DDC system shall not interrupt or interfere with normal network operation in any way, prevent alarms from being transmitted, or preclude central initiated commands and system modification.
- F. POT shall give operator the ability to do the following:
 - 1. Display and monitor BI point status.
 - 2. Change BO point set point (on or off, open or closed).
 - 3. Display and monitor analog point values.
 - 4. Change analog control set points.
 - 5. Command a setting of AO point.
 - 6. Display and monitor I/O point in alarm.
 - 7. Add a new or delete an existing I/O point.
 - 8. Enable and disable I/O points, initiators, and programs.
 - 9. Display and change time and date.
 - 10. Display and change time schedules.
 - 11. Display and change run-time counters and run-time limits.
 - 12. Display and change time and event initiation.
 - 13. Display and change control application and DDC parameters.
 - 14. Display and change programmable offset values.
 - 15. Access DDC controller initialization routines and diagnostics.

2.11 SYSTEM SOFTWARE

- A. System Software Minimum Requirements:
 - 1. Real-time multitasking and multiuser 64-bit operating system that allows concurrent multiple operator workstations operating and concurrent execution of multiple real-time programs and custom program development.
 - 2. Operating system shall be capable of operating DOS and Microsoft Windows applications.
 - 3. Database management software shall manage all data on an integrated and non-redundant basis. Additions and deletions to database shall be without detriment to existing data. Include cross linkages so no data required by a program can be deleted by an operator until that data have been deleted from respective programs.

4. Network communications software shall manage and control multiple-network communications to provide exchange of global information and execution of global programs.
5. Operator interface software shall include day-to-day operator transaction processing, alarm and report handling, operator privilege level and data segregation control, custom programming, and online data modification capability.
6. Scheduling software shall schedule centrally based time and event, temporary, and exception day programs.

B. Operator Interface Software:

1. Minimize operator training through use of English language pronouncing and English language point identification.
2. Minimize use of a typewriter-style keyboard through use of a pointing device similar to a mouse.
3. Operator sign-off shall be a manual operation or, if no keyboard or mouse activity takes place, an automatic sign-off.
4. Automatic sign-off period shall be programmable from one to 60 minutes in one-minute increments on a per operator basis.
5. Operator sign-on and sign-off activity shall be recorded and sent to printer.
6. Security Access:
 - a. Operator access to DDC system shall be under password control.
 - b. An alphanumeric password shall be field assignable to each operator.
 - c. Operators shall be able to access DDC system by entry of proper password.
 - d. Operator password shall be same regardless of which computer or other interface means is used.
 - e. Additions or changes made to passwords shall be updated automatically.
 - f. Each operator shall be assigned an access level to restrict access to data and functions the operator is capable of performing.
 - g. Software shall have at least five access levels.
 - h. Each menu item shall be assigned an access level so that a one-for-one correspondence between operator assigned access level(s) and menu item access level(s) is required to gain access to menu item.
 - i. Display menu items to operator with those capable of access highlighted. Menu and operator access level assignments shall be online programmable and under password control.
7. Data Segregation:
 - a. Include data segregation for control of specific data routed to a workstation, to an operator or to a specific output device, such as a printer.
 - b. Include at least 32 segregation groups.
 - c. Segregation groups shall be selectable such as "fire points," "fire points on second floor," "space temperature points," "HVAC points," and so on.
 - d. Points shall be assignable to multiple segregation groups. Display and output of data to printer or monitor shall occur where there is a match of operator or peripheral segregation group assignment and point segregations.

- e. Alarms shall be displayed and printed at each peripheral to which segregation allows, but only those operators assigned to peripheral and having proper authorization level will be allowed to acknowledge alarms.
 - f. Operators and peripherals shall be assignable to multiple segregation groups and all assignments are to be online programmable and under password control.
8. Operators shall be able to perform commands including, but not limited to, the following:
- a. Start or stop selected equipment.
 - b. Adjust set points.
 - c. Add, modify, and delete time programming.
 - d. Enable and disable process execution.
 - e. Lock and unlock alarm reporting for each point.
 - f. Enable and disable totalization for each point.
 - g. Enable and disable trending for each point.
 - h. Override control loop set points.
 - i. Enter temporary override schedules.
 - j. Define holiday schedules.
 - k. Change time and date.
 - l. Enter and modify analog alarm limits.
 - m. Enter and modify analog warning limits.
 - n. View limits.
 - o. Enable and disable demand limiting.
 - p. Enable and disable duty cycle.
 - q. Display logic programming for each control sequence
9. Reporting:
- a. Generated automatically and manually.
 - b. Sent to displays, printers and disk files.
 - c. Types of Reporting:
 - 1) General listing of points.
 - 2) List points currently in alarm.
 - 3) List of off-line points.
 - 4) List points currently in override status.
 - 5) List of disabled points.
 - 6) List points currently locked out.
 - 7) List of items defined in a "Follow-Up" file.
 - 8) List weekly schedules.
 - 9) List holiday programming.
 - 10) List of limits and deadbands.
10. Summaries: For specific points, for a logical point group, for an operator selected group(s), or for entire system without restriction due to hardware configuration.
- C. Graphic Interface Software:

1. Include a full interactive graphical selection means of accessing and displaying system data to operator. Include at least five levels with the penetration path operator assignable (for example, site, building, floor, air-handling unit, and supply temperature loop). Native language descriptors assigned to menu items are to be operator defined and modifiable under password control.
2. Include a hierarchical-linked dynamic graphic operator interface for accessing and displaying system data and commanding and modifying equipment operation. Interface shall use a pointing device with pull-down or penetrating menus, color and animation to facilitate operator understanding of system.
3. Include at least 10 levels of graphic penetration with the hierarchy operator assignable.
4. Descriptors for graphics, points, alarms and such shall be modified through operator's workstation under password control.
5. Graphic displays shall be online user definable and modifiable using the hardware and software provided.
6. Data to be displayed within a graphic shall be assignable regardless of physical hardware address, communication or point type.
7. Graphics are to be online programmable and under password control.
8. Points may be assignable to multiple graphics where necessary to facilitate operator understanding of system operation.
9. Graphics shall also contain software points.
10. Penetration within a graphic hierarchy shall display each graphic name as graphics are selected to facilitate operator understanding.
11. Back-trace feature shall permit operator to move upward in the hierarchy using a pointing device. Back trace shall show all previous penetration levels. Include operator with option of showing each graphic full screen size with back trace as horizontal header or by showing a "stack" of graphics, each with a back trace.
12. Display operator accessed data on the monitor.
13. Operator shall select further penetration using pointing device to click on a site, building, floor, area, equipment, and so on. Defined and linked graphic below that selection shall then be displayed.
14. Include operator with means to directly access graphics without going through penetration path.
15. Dynamic data shall be assignable to graphics.
16. Display points (physical and software) with dynamic data provided by DDC system with appropriate text descriptors, status or value, and engineering unit.
17. Use color, rotation, or other highly visible means, to denote status and alarm states. Color shall be variable for each class of points, as chosen by operator.
18. Points shall be dynamic with operator adjustable update rates on a per point basis from one second to over a minute.
19. For operators with appropriate privilege, points shall be commanded directly from display using pointing device.
 - a. For an analog command point such as set point, current conditions and limits shall be displayed and operator can position new set point using pointing device.
 - b. For a digital command point such as valve position, valve shall show its current state such as open or closed and operator could select alternative position using pointing device.

- c. Keyboard equivalent shall be available for those operators with that preference.
20. Operator shall be able to split or resize viewing screen into quadrants to show one graphic on one quadrant of screen and other graphics or spreadsheet, bar chart, word processing, curve plot and other information on other quadrants on screen. This feature shall allow real-time monitoring of one part of system while displaying other parts of system or data to better facilitate overall system operation.
21. Help Features:
- a. On-line context-sensitive help utility to facilitate operator training and understanding.
 - b. Bridge to further explanation of selected keywords. Document shall contain text and graphics to clarify system operation.
 - 1) If help feature does not have ability to bridge on keywords for more information, a complete set of user manuals shall be provided in an indexed word-processing program, which shall run concurrently with operating system software.
 - c. Available for Every Menu Item:
 - 1) Index items for each system menu item.
22. Graphic generation software shall allow operator to add, modify, or delete system graphic displays.
- a. Include libraries of symbols depicting HVAC symbols such as fans, coils, filters, dampers, valves pumps, and electrical symbols similar to those indicated.
 - b. Graphic development package shall use a pointing device in conjunction with a drawing program to allow operator to perform the following:
 - 1) Define background screens.
 - 2) Define connecting lines and curves.
 - 3) Locate, orient and size descriptive text.
 - 4) Define and display colors for all elements.
 - 5) Establish correlation between symbols or text and associated system points or other displays.
- D. Project-Specific Graphics: Graphics documentation including, but not limited to, the following:
- 1. Site plan showing each building, and additional site elements, which are being controlled or monitored by DDC system.
 - 2. Plan for each building floor, including interstitial floors, and each roof level of each building, showing the following:
 - a. Room layouts with room identification and name.

- b. Locations and identification of all monitored and controlled HVAC equipment and other equipment being monitored and controlled by DDC system.
 - c. Location and identification of each hardware point being controlled or monitored by DDC system.
3. Control schematic for each of following, including a graphic system schematic representation, similar to that indicated on Drawings, with point identification, set point and dynamic value indication, sequence of operation and control logic diagram.
 - a. Fuel system.
 - b. Heating hot-water system.
 - c. Boilers, and primary pumps
 - d. Hot Water system Pumps
 - e. Air-handling system and unit.
 - f. Fans
 - g. Terminal units
4. Graphic display for each piece of equipment connected to DDC system through a data communications link. Include dynamic indication of all points associated with equipment.
5. DDC system network riser diagram that shows schematic layout for entire system including all networks and all controllers, gateways operator workstations and other network devices.

E. Customizing Software:

1. Software to modify and tailor DDC system to specific and unique requirements of equipment installed, to programs implemented and to staffing and operational practices planned.
2. Online modification of DDC system configuration, program parameters, and database using menu selection and keyboard entry of data into preformatted display templates.
3. As a minimum, include the following modification capability:
 - a. Operator assignment shall include designation of operator passwords, access levels, point segregation and auto sign-off.
 - b. Peripheral assignment capability shall include assignment of segregation groups and operators to consoles and printers, designation of backup workstations and printers, designation of workstation header points and enabling and disabling of print-out of operator changes.
 - c. System configuration and diagnostic capability shall include communications and peripheral port assignments, DDC controller assignments to network, DDC controller enable and disable, assignment of command trace to points and application programs and initiation of diagnostics.

- d. System text addition and change capability shall include English or native language descriptors for points, segregation groups and access levels and action messages for alarms, run time and trouble condition.
 - e. Time and schedule change capability shall include time and date set, time and occupancy schedules, exception and holiday schedules and daylight savings time schedules.
 - f. Point related change capability shall include the following:
 - 1) System and point enable and disable.
 - 2) Run-time enable and disable.
 - 3) Assignment of points to segregation groups, calibration tables, lockout, and run time and to a fixed I/O value.
 - 4) Assignment of alarm and warning limits.
 - g. Application program change capability shall include the following:
 - 1) Enable and disable of software programs.
 - 2) Programming changes.
 - 3) Assignment of comfort limits, global points, time and event initiators, time and event schedules and enable and disable time and event programs.
4. Software shall allow operator to add points, or groups of points, to DDC system and to link them to energy optimization and management programs. Additions and modifications shall be online programmable using operator workstation, downloaded to other network devices and entered into their databases. After verification of point additions and associated program operation, database shall be uploaded and recorded on hard drive and disk for archived record.
 5. Include high-level language programming software capability for implementation of custom DDC programs. Software shall include a compiler, linker, and up- and down-load capability.
 6. Include a library of DDC algorithms, intrinsic control operators, arithmetic, logic and relational operators for implementation of control sequences. Also include, as a minimum, the following:
 - a. Proportional control (P).
 - b. Proportional plus integral (PI).
 - c. Proportional plus integral plus derivative (PID).
 - d. Adaptive and intelligent self-learning control.
 - 1) Algorithm shall monitor loop response to output corrections and adjust loop response characteristics according to time constant changes imposed.
 - 2) Algorithm shall operate in a continuous self-learning manner and shall retain in memory a stored record of system dynamics so that on system shut down and restart, learning process starts from where it left off.

7. Fully implemented intrinsic control operators including sequence, reversing, ratio, time delay, time of day, highest select AO, lowest select AO, analog controlled digital output, analog control AO, and digitally controlled AO.
8. Logic operators such as "And," "Or," "Not," and others that are part of a standard set available with a high-level language.
9. Arithmetic operators such as "Add," "Subtract," "Multiply," "Divide," and others that are part of a standard set available with a high-level language.
10. Relational operators such as "Equal To," "Not Equal To," "Less Than," "Greater Than," and others that are part of a standard set available with a high-level language.

F. Alarm Handling Software:

1. Include alarm handling software to report all alarm conditions monitored and transmitted through DDC controllers, gateways, and other network devices
2. Include first in, first out handling of alarms according to alarm priority ranking, with most critical alarms first, and with buffer storage in case of simultaneous and multiple alarms.
3. Alarm handling shall be active at all times to ensure that alarms are processed even if an operator is not currently signed on to DDC system.
4. Alarms display shall include the following:
 - a. Indication of alarm condition such as "Abnormal Off," "Hi Alarm," and "Low Alarm."
 - b. "Analog Value" or "Status" group and point identification with native language point descriptor such as "Space Temperature, Building , 2nd Floor, Room ."
 - c. Discrete per point alarm action message, such as "Call Maintenance Dept. Ext-5561."
 - d. Include extended message capability to allow assignment and printing of extended action messages. Capability shall be operator programmable and assignable on a per point basis.
5. Alarms shall be directed to appropriate operator workstations, printers, and individual operators by privilege level and segregation assignments.
6. Send e-mail alarm messages to designated operators.
7. Send e-mail, page, text and voice messages to designated operators for critical alarms.
8. Alarms shall be categorized and processed by class.
 - a. Class 1:
 - 1) Associated with fire, security and other extremely critical equipment monitoring functions; have alarm, trouble, return to normal, and acknowledge conditions printed and displayed.
 - 2) Unacknowledged alarms to be placed in unacknowledged alarm buffer.
 - 3) All conditions shall cause an audible sound and shall require individual acknowledgment to silence audible sound.

- b. Class 2:
 - 1) Critical, but not life-safety related, and processed same as Class 1 alarms, except do not require individual acknowledgment.
 - 2) Acknowledgement may be through a multiple alarm acknowledgment.
 - c. Class 3:
 - 1) General alarms; printed, displayed and placed in unacknowledged alarm buffer queues.
 - 2) Each new alarm received shall cause an audible sound. Audible sound shall be silenced by "acknowledging" alarm or by pressing a "silence" key.
 - 3) Acknowledgement of queued alarms shall be either on an individual basis or through a multiple alarm acknowledgement.
 - 4) Alarms returning to normal condition shall be printed and not cause an audible sound or require acknowledgment.
 - d. Class 4:
 - 1) Routine maintenance or other types of warning alarms.
 - 2) Alarms to be printed only, with no display, no audible sound and no acknowledgment required.
9. Include an unacknowledged alarm indicator on display to alert operator that there are unacknowledged alarms in system. Operator shall be able to acknowledge alarms on an individual basis or through a multiple alarm acknowledge key, depending on alarm class.
 10. To ensure that no alarm records are lost, it shall be possible to assign a backup printer to accept alarms in case of failure of primary printer.

G. Reports and Logs:

1. Include reporting software package that allows operator to select, modify, or create reports using DDC system I/O point data available.
2. Each report shall be definable as to data content, format, interval and date.
3. Report data shall be sampled and stored on DDC controller, within storage limits of DDC controller, and then uploaded to archive on [**workstation**] [**server**] for historical reporting.
4. Operator shall be able to obtain real-time logs of all I/O points by type or status, such as alarm, point lockout, or normal.
5. Reports and logs shall be stored on workstation, and server hard drives in a format that is readily accessible by other standard software applications, including spreadsheets and word processing.
6. Reports and logs shall be readily printed and set to be printed either on operator command or at a specific time each day.

- H. Standard Reports: Standard DDC system reports shall be provided and operator shall be able to customize reports later.

1. All I/O: With current status and values.
 2. Alarm: All current alarms, except those in alarm lockout.
 3. Disabled I/O: All I/O points that are disabled.
 4. Alarm Lockout I/O: All I/O points in alarm lockout, whether manual or automatic.
 5. Alarm Lockout I/O in Alarm: All I/O in alarm lockout that are currently in alarm.
 6. Logs:
 - a. Alarm history.
 - b. System messages.
 - c. System events.
 - d. Trends.
- I. Custom Reports: Operator shall be able to easily define any system data into a daily, weekly, monthly, or annual report. Reports shall be time and date stamped and shall contain a report title.
- J. Standard Trends:
1. Trend all I/O point present values, set points, and other parameters indicated for trending.
 2. Trends shall be associated into groups, and a trend report shall be set up for each group.
 3. Trends shall be stored within DDC controller and uploaded to hard drives automatically on reaching 75 of DDC controller buffer limit, or by operator request, or by archiving time schedule.
 4. Preset trend intervals for each I/O point after review with Owner.
 5. Trend intervals shall be operator selectable from 10 seconds up to 60 minutes. Minimum number of consecutive trend values stored at one time shall be 100 per variable.
 6. When drive storage memory is full, most recent data shall overwrite oldest data.
 7. Archived and real-time trend data shall be available for viewing numerically and graphically by operators.
- K. Custom Trends: Operator shall be able to define a custom trend log for any I/O point in DDC system.
1. Each trend shall include interval, start time, and stop time.
 2. Data shall be sampled and stored on DDC controller, within storage limits of DDC controller, and then uploaded to archive on workstation, server hard drives.
 3. Data shall be retrievable for use in spreadsheets and standard database programs.
- L. Programming Software:
1. Include programming software to execute sequences of operation indicated.
 2. Include programming routines in simple and easy to follow logic with detailed text comments describing what the logic does and how it corresponds to sequence of operation.
 3. Programming software shall be as follows:

- a. Graphic Based: Programming shall use a library of function blocks made from preprogrammed code designed for DDC control systems.
 - 1) Function blocks shall be assembled with interconnection lines that represent to control sequence in a flowchart.
 - 2) Programming tools shall be viewable in real time to show present values and logical results of each function block.
 - b. Menu Based: Programming shall be done by entering parameters, definitions, conditions, requirements and constraints.
 - c. Line by Line and Text Based: Programming shall declare variable types such as local, global, real, integer, and so on, at the beginning of the program. Use descriptive comments frequently to describe programming code.
4. Include means for detecting programming errors and testing software control strategies with a simulation tool before implementing in actual control. Simulation tool may be inherent with programming software or as a separate product.

M. Database Management Software:

1. Where a separate SQL database is used for information storage, DDC system shall include database management software that separates database monitoring and managing functions by supporting multiple separate windows.
2. Database secure access shall be accomplished using standard SQL authentication including ability to access data for use outside of DDC system applications.
3. Database management function shall include summarized information on trend, alarm, event, and audit for the following database management actions:
 - a. Backup.
 - b. Purge.
 - c. Restore.
4. Database management software shall support the following:
 - a. Statistics: Display database server information and trend, alarm, event, and audit information on database.
 - b. Maintenance: Include method of purging records from trend, alarm, event and audit databases by supporting separate screens for creating a backup before purging, selecting database, and allowing for retention of a selected number of day's data.
 - c. Backup: Include means to create a database backup file and select a storage location.
 - d. Restore: Include a restricted means of restoring a database by requiring operator to have proper security level.
5. Database management software shall include information of current database activity, including the following:

- a. Ready.
 - b. Purging record from a database.
 - c. Action failed.
 - d. Refreshing statistics.
 - e. Restoring database.
 - f. Shrinking a database.
 - g. Backing up a database.
 - h. Resetting Internet information services.
 - i. Starting network device manager.
 - j. Shutting down the network device manager.
 - k. Action successful.
6. Database management software monitoring functions shall continuously read database information once operator has logged on.
 7. Include operator notification through on-screen pop-up display and e-mail message when database value has exceeded a warning or alarm limit.
 8. Monitoring settings window shall have the following sections:
 - a. Allow operator to set and review scan intervals and start times.
 - b. E-mail: Allow operator to create and review e-mail and phone text messages to be delivered when a warning or an alarm is generated.
 - c. Warning: Allow operator to define warning limit parameters, set reminder frequency and link e-mail message.
 - d. Alarm: Allow operator to define alarm limit parameters, set reminder frequency and link e-mail message.
 - e. Database Login: Protect system from unauthorized database manipulation by creating a read access and a write access for each of trend, alarm, event and audit databases as well as operator proper security access to restore a database.
 9. Monitoring settings taskbar shall include the following informational icons:
 - a. Normal: Indicates by color and size, or other easily identifiable means that all databases are within their limits.
 - b. Warning: Indicates by color and size, or other easily identifiable means that one or more databases have exceeded their warning limit.
 - c. Alarm: Indicates by color and size, or other easily identifiable means that one or more databases have exceeded their alarm limit.

2.12 OFFICE APPLICATION SOFTWARE

- A. Include current version of office application software at time of Substantial Completion.
- B. Office application software package shall include multiple separate applications and use a common platform for all applications, similar to Microsoft's "Office Professional."
 1. Database.
 2. E-mail.
 3. Presentation.

4. Publisher.
5. Spreadsheet.
6. Word processing.

2.13 ASHRAE 135 GATEWAYS

- A. Include BACnet communication ports, whenever available as an equipment OEM standard option, for integration via a single communication cable. BACnet-controlled plant equipment includes, but is not limited to, boilers, AHU'S, Pumps, computer room air conditioners, and variable-speed drives.
- B. Include gateways to connect BACnet to legacy systems, existing non-BACnet devices, and existing non-BACnet DDC-controlled equipment, only when specifically requested and approved by Owner.
- C. Include with each gateway an interoperability schedule showing each point or event on legacy side that BACnet "client" will read, and each parameter that BACnet network will write to. Describe this interoperability of BACnet services, or BIBBs, defined in ASHRAE 135, Annex K.
- D. Gateway Minimum Requirements:
 1. Read and view all readable object properties on non-BACnet network to BACnet network and vice versa where applicable.
 2. Write to all writeable object properties on non-BACnet network from BACnet network and vice versa where applicable.
 3. Include single-pass (only one protocol to BACnet without intermediary protocols) translation from non-BACnet protocol to BACnet and vice versa.
 4. Comply with requirements of Data Sharing Read Property, Data Sharing Write Property, Device Management Dynamic Device Binding-B, and Device Management Communication Control BIBBs according to ASHRAE 135.
 5. Hardware, software, software licenses, and configuration tools for operator-to-gateway communications.
 6. Backup programming and parameters on CD media and the ability to modify, download, backup, and restore gateway configuration.

2.14 DDC CONTROLLERS

- A. DDC system shall consist of a combination of network controllers, programmable application controllers and application-specific controllers to satisfy performance requirements indicated.
- B. DDC controllers shall perform monitoring, control, energy optimization and other requirements indicated.
- C. DDC controllers shall use a multitasking, multiuser, real-time digital control microprocessor with a distributed network database and intelligence.

- D. Each DDC controller shall be capable of full and complete operation as a completely independent unit and as a part of a DDC system wide distributed network.
- E. Environment Requirements:
 - 1. Controller hardware shall be suitable for the anticipated ambient conditions.
 - 2. Controllers located in conditioned space shall be rated for operation at 32 to 120 deg F (Zero to 50 deg C).
 - 3. Controllers located outdoors shall be rated for operation at – 10.0 deg F to 90 deg G.
- F. Power and Noise Immunity:
 - 1. Controller shall operate at 90 to 110 percent of nominal voltage rating and shall perform an orderly shutdown below 80 percent of nominal voltage.
 - 2. Operation shall be protected against electrical noise of 5 to 120 Hz and from keyed radios with up to 5 W of power located within 36 inches (900 mm) of enclosure.
- G. DDC Controller Spare Processing Capacity:
 - 1. Include spare processing memory for each controller. RAM, PROM, or EEPROM will implement requirements indicated with the following spare memory:
 - a. Network Controllers: 50 percent.
 - b. Programmable Application Controllers: Not less than 70 percent.
 - c. Application-Specific Controllers: Not less than 100 percent.
 - 2. Memory shall support DDC controller's operating system and database and shall include the following:
 - a. Monitoring and control.
 - b. Energy management, operation and optimization applications.
 - c. Alarm management.
 - d. Historical trend data of all connected I/O points.
 - e. Maintenance applications.
 - f. Operator interfaces.
 - g. Monitoring of manual overrides.
- H. DDC Controller Spare I/O Point Capacity: Include spare I/O point capacity for each controller as follows:
 - 1. Network Controllers:
 - a. 20 percent of each AI, AO, BI, and BO point connected to controller.
 - b. Minimum Spare I/O Points per Controller:
 - 1) AIs: 3
 - 2) AOs: 3
 - 3) BIs: 5
 - 4) BOs: 5.

2. Programmable Application Controllers:
 - a. 20 percent of each AI, AO, BI, and BO point connected to controller.
 - b. Minimum Spare I/O Points per Controller:
 - 1) AIs: 3.
 - 2) AOs: 3.
 - 3) BIs: 5.
 - 4) BOs: 5.

3. Application-Specific Controllers:
 - a. 20 percent of each AI, AO, BI, and BO point connected to controller.
 - b. Minimum Spare I/O Points per Controller:
 - 1) AIs: 2.
 - 2) AOs: 2.
 - 3) BIs: 2.
 - 4) BOs: 2.

I. Maintenance and Support: Include the following features to facilitate maintenance and support:

1. Mount microprocessor components on circuit cards for ease of removal and replacement.
2. Means to quickly and easily disconnect controller from network.
3. Means to quickly and easily access connect to field test equipment.
4. Visual indication that controller electric power is on, of communication fault or trouble, and that controller is receiving and sending signals to network.

J. Input and Output Point Interface:

1. Hardwired input and output points shall connect to network, programmable application and application-specific controllers.
2. Input and output points shall be protected so shorting of point to itself, to another point, or to ground will not damage controller.
3. Input and output points shall be protected from voltage up to 24 V of any duration so that contact will not damage controller.
4. AIs:
 - a. AIs shall include monitoring of low-voltage (zero- to 10-V dc), current (4 to 20 mA) and resistance signals from thermistor and RTD sensors.
 - b. AIs shall be compatible with, and field configurable to, sensor and transmitters installed.
 - c. Controller AIs shall perform analog-to-digital (A-to-D) conversion with a minimum resolution of 12 bits or better to comply with accuracy requirements indicated.
 - d. Signal conditioning including transient rejection shall be provided for each AI.
 - e. Capable of being individually calibrated for zero and span.

- f. Incorporate common-mode noise rejection of at least 50 dB from zero to 100 Hz for differential inputs, and normal-mode noise rejection of at least 20 dB at 60 Hz from a source impedance of 10000 ohms.
5. AOs:
- a. Controller AOs shall perform analog-to-digital (A-to-D) conversion with a minimum resolution of 12 bits or better to comply with accuracy requirements indicated.
 - b. Output signals shall have a range of 4 to 20 mA dc, or zero- to 10-V dc as required to include proper control of output device.
 - c. Capable of being individually calibrated for zero and span.
 - d. AOs shall not exhibit a drift of greater than 0.4 percent of range per year.
6. BIs:
- a. Controller BIs shall accept contact closures and shall ignore transients of less than 5-ms duration.
 - b. Isolation and protection against an applied steady-state voltage of up to 180-V ac peak.
 - c. BIs shall include a wetting current of at least 12 mA to be compatible with commonly available control devices and shall be protected against effects of contact bounce and noise.
 - d. BIs shall sense "dry contact" closure without external power (other than that provided by the controller) being applied.
 - e. Pulse accumulation input points shall comply with all requirements of BIs and accept up to 10 pulses per second for pulse accumulation. Buffer shall be provided to totalize pulses. Pulse accumulator shall accept rates of at least 20 pulses per second. The totalized value shall be reset to zero on operator's command.
7. BOs:
- a. Controller BOs shall include relay contact closures or triac outputs for momentary and maintained operation of output devices.
 - 1) Relay contact closures shall have a minimum duration of 0.1 second. Relays shall include at least 180 V of isolation. Electromagnetic interference suppression shall be provided on all output lines to limit transients to non-damaging levels. Minimum contact rating shall be 1 A at 24-V ac.
 - 2) Triac outputs shall include at least 180 V of isolation. Minimum contact rating shall be 1 A at 24-V ac.
 - b. BOs shall include for two-state operation or a pulsed low-voltage signal for pulse-width modulation control.
 - c. BOs shall be selectable for either normally open or normally closed operation.
 - d. Include tristate outputs (two coordinated BOs) for control of three-point floating-type electronic actuators without feedback.

- e. Limit use of three-point floating devices to VAV terminal unit control applications, and other applications indicated on Drawings. Control algorithms shall operate actuator to one end of its stroke once every 12 hours for verification of operator tracking.

2.15 NETWORK CONTROLLERS

A. General Network Controller Requirements:

1. Include adequate number of controllers to achieve performance indicated.
2. System shall consist of one or more independent, standalone, microprocessor-based network controllers to manage global strategies indicated.
3. Controller shall have enough memory to support its operating system, database, and programming requirements.
4. Data shall be shared between networked controllers and other network devices.
5. Operating system of controller shall manage input and output communication signals to allow distributed controllers to share real and virtual object information and allow for central monitoring and alarms.
6. Controllers that perform scheduling shall have a real-time clock.
7. Controller shall continually check status of its processor and memory circuits. If an abnormal operation is detected, controller shall assume a predetermined failure mode and generate an alarm notification.
8. Controllers shall be fully programmable.

B. Communication:

1. Network controllers shall communicate with other devices on DDC system **Level one** network.
2. Network controller also shall perform routing if connected to a network of programmable application and application-specific controllers.

C. Operator Interface:

1. Controller shall be equipped with a service communications port for connection to a portable operator's workstation.
2. Local Keypad and Display:
 - a. Equip controller with local keypad and digital display for interrogating and editing data.
 - b. Use of keypad and display shall require security password.

D. Serviceability:

1. Controller shall be equipped with diagnostic LEDs or other form of local visual indication of power, communication, and processor.
2. Wiring and cable connections shall be made to field-removable, modular terminal strips or to a termination card connected by a ribbon cable.
3. Controller shall maintain BIOS and programming information in event of a power loss for at least 96 hours.

2.16 PROGRAMMABLE APPLICATION CONTROLLERS

A. General Programmable Application Controller Requirements:

1. Include adequate number of controllers to achieve performance indicated.
2. Controller shall have enough memory to support its operating system, database, and programming requirements.
3. Data shall be shared between networked controllers and other network devices.
4. Operating system of controller shall manage input and output communication signals to allow distributed controllers to share real and virtual object information and allow for central monitoring and alarms.
5. Controllers that perform scheduling shall have a real-time clock.
6. Controller shall continually check status of its processor and memory circuits. If an abnormal operation is detected, controller shall assume a predetermined failure mode and generate an alarm notification.
7. Controllers shall be fully programmable.

B. Communication:

1. Programmable application controllers shall communicate with other devices on network.

C. Operator Interface:

1. Controller shall be equipped with a service communications port for connection to a portable operator's workstation.
2. Local Keypad and Display:
 - a. Equip controller with local keypad and digital display for interrogating and editing data.
 - b. Use of keypad and display shall require security password.

D. Serviceability:

1. Controller shall be equipped with diagnostic LEDs or other form of local visual indication of power, communication, and processor.
2. Wiring and cable connections shall be made to field-removable, modular terminal strips or to a termination card connected by a ribbon cable.
3. Controller shall maintain BIOS and programming information in event of a power loss for at least 96 hours.

2.17 APPLICATION-SPECIFIC CONTROLLERS

A. Description: Microprocessor-based controllers, which through hardware or firmware design are dedicated to control a specific piece of equipment. Controllers are not fully user-programmable but are configurable and customizable for operation of equipment they are designed to control.

1. Capable of standalone operation and shall continue to include control functions without being connected to network.

2. Data shall be shared between networked controllers and other network devices.
- B. Communication: Application-specific controllers shall communicate with other application-specific controller and devices on network, and to programmable application and network controllers.
 - C. Operator Interface: Controller shall be equipped with a service communications port for connection to a portable operator's workstation. Connection shall extend to port on space temperature sensor that is connected to controller.
 - D. Serviceability:
 1. Controller shall be equipped with diagnostic LEDs or other form of local visual indication of power, communication, and processor.
 2. Wiring and cable connections shall be made to field-removable, modular terminal strips or to a termination card connected by a ribbon cable.
 3. Controller shall use nonvolatile memory and maintain all BIOS and programming information in event of power loss.

2.18 CONTROLLER SOFTWARE

- A. General Controller Software Requirements:
 1. Software applications shall reside and operate in controllers. Editing of applications shall occur at operator workstations.
 2. I/O points shall be identified by up to 30-character point name and up to 16-character point descriptor. Same names shall be used at operator workstations.
 3. Control functions shall be executed within controllers using DDC algorithms.
 4. Controllers shall be configured to use stored default values to ensure fail-safe operation. Default values shall be used when there is a failure of a connected input instrument or loss of communication of a global point value.
- B. Security:
 1. Operator access shall be secured using individual security passwords and user names.
 2. Passwords shall restrict operator to points, applications, and system functions as assigned by system manager.
 3. Operator log-on and log-off attempts shall be recorded.
 4. System shall protect itself from unauthorized use by automatically logging off after last keystroke. The delay time shall be operator-definable.
- C. Scheduling: Include capability to schedule each point or group of points in system. Each schedule shall consist of the following:
 1. Weekly Schedule:
 - a. Include separate schedules for each day of week.
 - b. Each schedule should include the capability for start, stop, optimal start, optimal stop, and night economizer.

- c. Each schedule may consist of up to 10 events.
 - d. When a group of objects are scheduled together, include capability to adjust start and stop times for each member.
 2. Exception Schedules:
 - a. Include ability for operator to designate any day of the year as an exception schedule.
 - b. Exception schedules may be defined up to a year in advance. Once an exception schedule is executed, it will be discarded and replaced by regular schedule for that day of week.
 3. Holiday Schedules:
 - a. Include capability for operator to define up to 99 special or holiday schedules.
 - b. Schedules may be placed on scheduling calendar and will be repeated each year.
 - c. Operator shall be able to define length of each holiday period.
- D. System Coordination:
 1. Include standard application for proper coordination of equipment.
 2. Application shall include operator with a method of grouping together equipment based on function and location.
 3. Group may then be used for scheduling and other applications.
- E. Binary Alarms:
 1. Each binary point shall be set to alarm based on operator-specified state.
 2. Include capability to automatically and manually disable alarming.
- F. Analog Alarms:
 1. Each analog object shall have both high and low alarm limits.
 2. Alarming shall be able to be automatically and manually disabled.
- G. Alarm Reporting:
 1. Operator shall be able to determine action to be taken in event of an alarm.
 2. Alarms shall be routed to appropriate operator workstations based on time and other conditions.
 3. Alarm shall be able to start programs, print, be logged in event log, generate custom messages, and display graphics.
- H. Remote Communication:
 1. System shall have ability to dial out in the event of an alarm.
- I. Electric Power Demand Limiting:

1. Demand-limiting program shall monitor building or other operator-defined electric power consumption from signals connected to electric power meter or from a watt transducer or current transformer.
 2. Demand-limiting program shall predict probable power demand such that action can be taken to prevent exceeding demand limit. When demand prediction exceeds demand limit, action will be taken to reduce loads in a predetermined manner. When demand prediction indicates demand limit will not be exceeded, action will be taken to restore loads in a predetermined manner.
 3. Demand reduction shall be accomplished by the following means:
 - a. Reset air-handling unit supply temperature set points.
 - b. Reset space temperature set points.
 - c. De-energize equipment based on priority.
 4. Demand-limiting parameters, frequency of calculations, time intervals, and other relevant variables shall be based on the means by which electric power service provider computes demand charges.
 5. Include demand-limiting prediction and control for any individual meter monitored by system or for total of any combination of meters.
 6. Include means operator to make the following changes online:
 - a. Addition and deletion of loads controlled.
 - b. Changes in demand intervals.
 - c. Changes in demand limit for meter(s).
 - d. Maximum shutoff time for equipment.
 - e. Minimum shutoff time for equipment.
 - f. Select rotational or sequential shedding and restoring.
 - g. Shed and restore priority.
 7. Include the following information and reports, to be available on an hourly, daily, weekly, monthly and annual basis:
 - a. Total electric consumption.
 - b. Peak demand.
 - c. Date and time of peak demand.
 - d. Daily peak demand.
- J. Maintenance Management: System shall monitor equipment status and generate maintenance messages based on operator-designated run-time, starts, and calendar date limits.
- K. Sequencing: Include application software based on sequences of operation indicated to properly sequence chillers, boilers, and other applicable HVAC equipment.
- L. Control Loops:
1. Support any of the following control loops, as applicable to control required:
 - a. Two-position (on/off, open/close, slow/fast) control.
 - b. Proportional control.

- c. Proportional plus integral (PI) control.
 - d. Proportional plus integral plus derivative (PID) control.
 - 1) Include PID algorithms with direct or reverse action and anti-windup.
 - 2) Algorithm shall calculate a time-varying analog value used to position an output or stage a series of outputs.
 - 3) Controlled variable, set point, and PID gains shall be operator-selectable.
 - e. Adaptive (automatic tuning).
- M. Staggered Start: Application shall prevent all controlled equipment from simultaneously restarting after a power outage. Order which equipment (or groups of equipment) is started, along with the time delay between starts, shall be operator-selectable.
- N. Anti-Short Cycling:
- 1. BO points shall be protected from short cycling.
 - 2. Feature shall allow minimum on-time and off-time to be selected.
- O. On and Off Control with Differential:
- 1. Include an algorithm that allows a BO to be cycled based on a controlled variable and set point.
 - 2. Algorithm shall be direct- or reverse-acting and incorporate an adjustable differential.
- P. Run-Time Totalization:
- 1. Include software to totalize run-times for all BI and BO points.
 - 2. A high run-time alarm shall be assigned, if required, by operator.

2.19 ENCLOSURES

- A. General Enclosure Requirements:
- 1. Basis of design product: Based on approval, provide as indicated by the following or equal: Hoffman, a brands of Pentar.
 - 2. House each controller and associated control accessories in a single enclosure. Enclosure shall serve as central tie-in point for control devices such as switches, transmitters, transducers, power supplies and transformers.
 - 3. Do not house more than one controller in a single enclosure.
 - 4. Include enclosure door with key locking mechanism. Key locks alike for all enclosures and include one pair of keys per enclosure.
 - 5. Equip doors of enclosures housing controllers and components with analog or digital displays with windows to allow visual observation of displays without opening enclosure door.
 - 6. Individual wall-mounted single-door enclosures shall not exceed 36 inches wide and 60 inches (1500 mm) high.

7. Individual wall-mounted double-door enclosures shall not exceed 60 inches (1500 mm) wide and 36 inches (900 mm) high.
8. Include wall-mounted enclosures with brackets suitable for mounting enclosures to wall or freestanding support stand as indicated.
9. Supply each enclosure with a complete set of as-built schematics, tubing, and wiring diagrams and product literature located in a pocket on inside of door. For enclosures with windows, include pocket on bottom of enclosure.

B. Internal Arrangement:

1. Internal layout of enclosure shall group and protect pneumatic, electric, and electronic components associated with a controller, but not an integral part of controller.
2. Arrange layout to group similar products together.
3. Include a barrier between line-voltage and low-voltage electrical and electronic products.
4. Factory or shop install products, tubing, cabling and wiring complying with requirements and standards indicated.
5. Terminate field cable and wire using heavy-duty terminal blocks.
6. Include spare terminals, equal to not less than 20 percent of used terminals.
7. Include spade lugs for stranded cable and wire.
8. Install a maximum of two wires on each side of a terminal.
9. Include enclosure field power supply with a toggle-type switch located at entrance inside enclosure to disconnect power.
10. Include enclosure with a line-voltage nominal 20-A GFCI duplex receptacle for service and testing tools. Wire receptacle on hot side of enclosure disconnect switch and include with a 5-A circuit breaker.
11. Mount products within enclosure on removable internal panel(s).
12. Include products mounted in enclosures with engraved, laminated phenolic nameplates (black letters on a white background). The nameplates shall have at least 1/4-inch- (6-mm-) high lettering.
13. Route tubing cable and wire located inside enclosure within a raceway with a continuous removable cover.
14. Label each end of cable, wire and tubing in enclosure following an approved identification system that extends from field I/O connection and all intermediate connections throughout length to controller connection.
15. Size enclosure internal panel to include at least 25 percent spare area on face of panel.

C. Environmental Requirements:

1. Evaluate temperature and humidity requirements of each product to be installed within each enclosure.
2. Calculate enclosure internal operating temperature considering heat dissipation of all products installed within enclosure and ambient effects (solar, conduction and wind) on enclosure.
3. Where required by application, include temperature-controlled electrical heat to maintain inside of enclosure above minimum operating temperature of product with most stringent requirement.

4. Where required by application, include temperature-controlled ventilation fans with filtered louver(s) to maintain inside of enclosure below maximum operating temperature of product with most stringent requirement.

D. Wall-Mounted, NEMA 250, Type 1:

1. Enclosure shall be NRTL listed according to UL 50 or UL 50E.
2. Construct enclosure of steel, not less than:
 - a. Enclosure size less than 24 in. (600 mm): 0.067 in. (1.7 mm) thick.
 - b. Enclosure size 24 in. (600 mm) and larger: 0.093 in. (2.36 mm)] thick.
3. Finish enclosure inside and out with polyester powder coating that is electrostatically applied and then baked to bond to substrate.
 - a. Exterior color shall be manufacturer's standard, or color selected by Architect in exposed occupied areas.
 - b. Interior color shall be manufacturer's standard.
4. Hinged door full size of front face of enclosure and supported using:
 - a. Enclosures sizes less than 36 in. (900 mm) tall: Multiple butt hinges.
 - b. Enclosures sizes 36 in. (900 mm) tall and larger: Continuous piano hinges.
5. Removable internal panel with a white polyester powder coating that is electrostatically applied and then baked to bond to substrate.
 - a. Size less than 24 in. (600 mm): Solid steel, 0.053 in. (1.35 mm) thick.
 - b. Size 24 in. (600 mm) and larger: Solid aluminum, 0.10 in. (3 mm), or steel, 0.093 in. (2.36 mm) thick.
6. Internal panel mounting hardware, grounding hardware and sealing washers.
7. Grounding stud on enclosure body.
8. Thermoplastic pocket on inside of door for record Drawings and Product Data.

E. Wall Mounted NEMA 250, Types 4 and 12:

1. Enclosure shall be NRTL listed according to UL 508A.
2. Seam and joints are continuously welded and ground smooth.
3. Where recessed enclosures are indicated, include enclosures with face flange for flush mounting.
4. Externally formed body flange around perimeter of enclosure face for continuous perimeter seamless gasket door seal.
5. Single-door enclosure sizes up to 60 inches tall by 36 inches wide (1500 mm tall by 900 mm wide).
6. Double-door enclosure sizes up to 36 inches tall by 60 inches wide (900 mm tall by 1500 mm wide).
7. Construct enclosure of steel, not less than the following:
 - a. Size Less Than 24 Inches (600 mm): 0.067 inch (1.7 mm) thick.
 - b. Size 24 Inches (600 mm) and Larger: 0.067 inch (1.7 mm) thick.

8. Finish enclosure with polyester powder coating that is electrostatically applied and then baked to bond to substrate.
 - a. Exterior color shall be manufacturer's standard., or selected by Architect if in exposed occupied area.
 - b. Interior color shall be manufacturer's standard.
9. Corner-formed door, full size of enclosure face, supported using multiple concealed hinges with easily removable hinge pins.
 - a. Sizes through 24 Inches (600 mm) Tall: Two hinges.
 - b. Sizes between 24 Inches (600 mm) through 48 Inches (1200 mm) Tall: Three hinges.
 - c. Sizes Larger 48 Inches (1200 mm) Tall: Four hinges.
10. Double-door enclosures with overlapping door design to include unobstructed full-width access.
 - a. Single-door enclosures 48 inches (1200 mm) and taller, and all double-door enclosures, with three-point (top, middle and bottom) latch system.
11. Removable internal panel with a white polyester powder coating that is electrostatically applied and then baked to bond to substrate.
 - a. Size Less Than 24 Inches (600 mm): Solid steel, 0.053 inch (1.35 mm) thick.
 - b. Size 24 Inches (600 mm) and Larger: Solid aluminum, 0.10 inch (3 mm), or steel, 0.093 inch (2.36 mm) thick.
12. Internal panel mounting studs with hardware, grounding hardware, and sealing washers.
13. Grounding stud on enclosure body.
14. Thermoplastic pocket on inside of door for record Drawings and Product Data.

F. Accessories:

1. Electric Heater:
 - a. Aluminum housing with brushed finish.
 - b. Thermostatic control with adjustable set point from – 10.0 to 100 deg F (Minus 18 to 38 deg C).
 - c. Capacity: 100, 200, 400, and 800 W as required by application.
 - d. Fan draws cool air from bottom of enclosure and passes air across thermostat and heating elements before being released into enclosure cavity. Heated air is discharged through the top of heater.
2. Ventilation Fans, Filtered Intake and Exhaust Grilles:
 - a. Number and size of fans, filters and grilles as required by application.
 - b. Compact cooling fans engineered for 50,000 hours of continuous operation without lubrication or service.

- c. Fans capable of being installed on any surface and in any position within enclosure for spot cooling or air circulation.
 - d. Thermostatic control with adjustable set point from 32 to 140 deg F (Zero to 60 deg C).
 - e. Airflow Capacity at Zero Pressure:
 - 1) 4-Inch (100-mm) Fan: 100 cfm (47 L/s).
 - 2) 6-Inch (150-mm) Fan: 240 cfm (113 L/s).
 - 3) 10-Inch (250-mm) Fan: 560 cfm (264 L/s).
 - f. Maximum operating temperature of 158 deg F (70 deg C).
 - g. 4-inch (100-mm) fan thermally protected and provided with permanently lubricated ball-bearings.
 - h. 6- and 10-inch (150- and 250-mm) fans with ball-bearing construction and split capacitor motors thermally protected to avoid premature failure.
 - i. Dynamically balanced impellers molded from polycarbonate material.
 - j. Fan furnished with power cord and polarized plug for power connection.
 - k. Fan brackets, finger guards and mounting hardware provided with fans to complete installation.
 - l. Removable Intake and Exhaust Grilles: ABS plastic, or stainless steel of size to match fan size and suitable for NEMA 250, Types 1 and 12 enclosures.
 - m. Filters for NEMA 250, Type 1 Enclosures: Washable foam, or aluminum, of a size to match intake grille.
 - n. Filters for NEMA 250, Type 12 Enclosures: Disposable, of a size to match intake grille.
3. Framed Fixed Window Kit for NEMA 250, Types 4, 4X, and 12 Enclosures:
- a. 0.25-inch- (6-mm-) thick, scratch-resistant acrylic or polycarbonate window mounted in a metal frame matching adjacent door material.
 - b. Enclosure types, except NEMA 250 Type 1, shall have a continuous gasket material around perimeter of window and frame to provide watertight seal.
 - c. Window kit shall be factory or shop installed before shipment to Project.
4. Frameless Fixed Window Kit for NEMA 250, Type 1 Enclosures:
- a. 0.125-inch- (3-mm-) thick, polycarbonate window mounted in enclosure door material.
 - b. Window attached to door with screw fasteners and continuous strip of high-strength double-sided tape around window perimeter.
 - c. Window kit shall be factory or shop installed before shipment to Project.
5. Frame Fixed or Hinged Window Kit for NEMA 250, Types 1 and 12 Enclosures:
- a. 0.25-inch- (6-mm-) thick, scratch-resistant acrylic or polycarbonate window mounted in a metal frame matching adjacent door material.
 - b. Enclosure types, except NEMA 250 Type 1, shall have a continuous gasket material around perimeter of window and frame to provide watertight seal.
 - c. Window kit shall be factory or shop installed before shipment to Project.

6. Bar handle with keyed cylinder lock set.

2.20 RELAYS

A. General-Purpose Relays:

1. Relays shall be heavy duty and rated for at least 10 A at 250-V ac and 60 Hz.
2. Relays shall be either double pole double throw (DPDT) or three-pole double throw, depending on the control application.
3. Use a plug-in-style relay with an eight-pin octal plug for DPDT relays and an 11-pin octal plug for three-pole double-throw relays.
4. Construct the contacts of either silver cadmium oxide or gold.
5. Enclose the relay in a clear transparent polycarbonate dust-tight cover.
6. Relays shall have LED indication and a manual reset and push-to-test button.
7. Performance:
 - a. Mechanical Life: At least 10 million cycles.
 - b. Electrical Life: At least 100,000 cycles at rated load.
 - c. Pickup Time: 15 ms or less.
 - d. Dropout Time: 10 ms or less.
 - e. Pull-in Voltage: 85 percent of rated voltage.
 - f. Dropout Voltage: 50 percent of nominal rated voltage.
 - g. Power Consumption: 2 VA.
 - h. Ambient Operating Temperatures: Minus 40 to 115 deg F (Minus 40 to 46 deg C).
8. Equip relays with coil transient suppression to limit transients to non-damaging levels.
9. Plug each relay into an industry-standard, 35-mm DIN rail socket. Plug all relays located in control panels into sockets that are mounted on a DIN rail.
10. Relay socket shall have screw terminals. Mold into the socket the coincident screw terminal numbers and associated octal pin numbers.

B. Multifunction Time-Delay Relays:

1. Relays shall be continuous duty and rated for at least 10 A at 240-V ac and 60 Hz.
2. Relays shall be DPDT relay with up to eight programmable functions to provide on/off delay, interval and recycle timing functions.
3. Use a plug-in-style relay with either an 8- or 11-pin octal plug.
4. Construct the contacts of either silver cadmium oxide or gold.
5. Enclose the relay in a dust-tight cover.
6. Include knob and dial scale for setting delay time.
7. Performance:
 - a. Mechanical Life: At least 10 million cycles.
 - b. Electrical Life: At least 100,000 cycles at rated load.
 - c. Timing Ranges: Multiple ranges from 0.1 seconds to 100 minutes.
 - d. Repeatability: Within 2 percent.
 - e. Recycle Time: 45 ms.
 - f. Minimum Pulse Width Control: 50 ms.
 - g. Power Consumption: 5 VA or less at 120-V ac.

- h. Ambient Operating Temperatures: Minus 40 to 115 deg F (Minus 40 to 46 deg C).
 8. Equip relays with coil transient suppression to limit transients to non-damaging levels.
 9. Plug each relay into an industry-standard, 35-mm DIN rail socket. Plug all relays located in control panels into sockets that are mounted on a DIN rail.
 10. Relay socket shall have screw terminals. Mold into the socket the coincident screw terminal numbers and associated octal pin numbers.
- C. Latching Relays:
 1. Relays shall be continuous duty and rated for at least 10 A at 250-V ac and 60 Hz.
 2. Relays shall be either DPDT or three-pole double throw, depending on the control application.
 3. Use a plug-in-style relay with a multibladed plug.
 4. Construct the contacts of either silver cadmium oxide or gold.
 5. Enclose the relay in a clear transparent polycarbonate dust-tight cover.
 6. Performance:
 - a. Mechanical Life: At least 10 million cycles.
 - b. Electrical Life: At least 100,000 cycles at rated load.
 - c. Pickup Time: 15 ms or less.
 - d. Dropout Time: 10 ms or less.
 - e. Pull-in Voltage: 85 percent of rated voltage.
 - f. Dropout Voltage: 50 percent of nominal rated voltage.
 - g. Power Consumption: 2 VA.
 - h. Ambient Operating Temperatures: Minus 40 to 115 deg F (Minus 40 to 46 deg C).
 7. Equip relays with coil transient suppression to limit transients to non-damaging levels.
 8. Plug each relay into an industry-standard, 35-mm DIN rail socket. Plug all relays located in control panels into sockets that are mounted on a DIN rail.
 9. Relay socket shall have screw terminals. Mold into the socket the coincident screw terminal numbers and associated octal pin numbers.
- D. Current Sensing Relay:
 1. Monitors ac current.
 2. Independent adjustable controls for pickup and dropout current.
 3. Energized when supply voltage is present and current is above pickup setting.
 4. De-energizes when monitored current is below dropout current.
 5. Dropout current is adjustable from 50 to 95 percent of pickup current.
 6. Include a current transformer, if required for application.
 7. House current sensing relay and current transformer in its own enclosure. Use NEMA 250, Type 12 enclosure for indoors and NEMA 250, Type 4 for outdoors.
- E. Combination On-Off Status Sensor and On-Off Relay:
 1. Description:
 - a. On-off control and status indication in a single device.

- b. LED status indication of activated relay and current trigger.
 - c. Closed-Open-Auto override switch located on the load side of the relay.
2. Performance:
- a. Ambient Temperature: Minus 30 to 140 deg F (Minus 34 to 60 deg C).
 - b. Voltage Rating: Single-phase loads rated for 300-V ac. Three-phase loads rated for 600-V ac.
3. Status Indication:
- a. Current Sensor: Integral sensing for single-phase loads up to 20 A and external solid or split sensing ring for three-phase loads up to 150 A.
 - b. Current Sensor Range: As required by application.
 - c. Current Set Point: Fixed or adjustable as required by application.
 - d. Current Sensor Output:
 - 1) Solid-state, single-pole double-throw contact rated for 30-V ac and dc and for 0.4 A.
 - 2) Solid-state, single-pole double-throw contact rated for 120-V ac and 1.0 A.
 - 3) Analog, zero- to 5- or 10-V dc.
 - 4) Analog, 4 to 20 mA, loop powered.
4. Relay: Single-pole double-throw, continuous-duty coil; rated for 10-million mechanical cycles.
5. Enclosure: NEMA 250, Type 1 enclosure.

2.21 ELECTRICAL POWER DEVICES

A. Transformers:

- 1. Transformer shall be sized for the total connected load, plus an additional 25 percent of connected load.
- 2. Transformer shall be at least 100 VA.
- 3. Transformer shall have both primary and secondary fuses.

B. DC Power Supply:

- 1. Plug-in style suitable for mating with a standard eight-pin octal socket. Include the power supply with a mating mounting socket.
- 2. Enclose circuitry in a housing.
- 3. Include both line and load regulation to ensure a stable output. To protect both the power supply and the load, power supply shall have an automatic current limiting circuit.
- 4. Backup Power:
- 5. Performance:
 - a. Output voltage nominally 25-V dc within 5 percent.
 - b. Output current up to 100 mA.

- c. Input voltage nominally 120-V ac, 60 Hz.
- d. Load regulation within 0.5 percent from zero- to 100-mA load.
- e. Line regulation within 0.5 percent at a 100-mA load for a 10 percent line change.
- f. Stability within 0.1 percent of rated volts for 24 hours after a 20-minute warmup.

2.22 EMERGENCY GENERATOR

A. Emergency Power:

1. Emergency Generator shall provide continuous, regulated output power during brown-out, loss of power throughout conditions.

2.23 PIPING AND TUBING

A. Pneumatic, and Pressure Instrument Signal Air, Tubing and Piping:

1. Products in this paragraph are intended for use with the following:
 - a. Main air and signal air to pneumatically controlled instruments, actuators and other control devices and accessories.
 - b. Signal air between pressure instruments, such as sensors, switches, transmitters, controllers, and accessories.
2. Copper Tubing:
 - a. Seamless phosphor deoxidized copper, soft annealed or drawn tempered, with chemical and physical properties according to ASTM B 75.
 - b. Performance, dimensions, weight and tolerance according to ASTM B 280.
 - c. Diameter, as required by application, not less than nominal 0.25 inch (6 mm).
 - d. Wall thickness, as required by the application, but not less than 0.030 inch.
3. Copper Tubing Connectors and Fittings:
 - a. Brass, compression type.
 - b. Brass, solder-joint type.
4. Polyethylene Tubing:
 - a. Fire-resistant black virgin polyethylene according to ASTM D 1248, Type 1, Class C and Grade 5.
 - b. Tubing shall comply with stress crack test according to ASTM D 1693.
 - c. Diameter, as required by application, of not less than nominal 0.25 inch (6 mm).
5. Polyethylene Tubing Connectors and Fittings:

- a. Brass, barbed fittings.
- b. Brass, compression type.

B. Process Tubing:

- 1. Products in this paragraph are intended for signals to instruments connected to liquid and steam systems.
- 2. Copper Tubing:
 - a. Seamless phosphor deoxidized copper, soft annealed or drawn tempered with chemical and physical properties according to ASTM B 75.
 - b. Performance, dimensions, weight and tolerance according to ASTM B 280.
 - c. Diameter, as required by application, of not less than nominal 0.25 inch (6 mm).
 - d. Wall thickness, as required by application, but not less than 0.030 inch (0.8 mm).
- 3. Copper Tubing Connectors and Fittings:
 - a. Brass, compression type.
 - b. Brass, solder-joint type.

2.24 CONTROL WIRE AND CABLE

A. Wire: Single conductor control wiring above 24 V.

- 1. Wire size shall be at least **No. 16** AWG, or as required based on the distances of the wire and permissible voltage drops.
- 2. Conductor shall be 7/24 soft annealed copper strand with 2- to 2.5-inch (50- to 65-mm) lay.
- 3. Conductor insulation shall be 600 V, Type THWN or Type THHN, and 90 deg C according to UL 83.
- 4. Conductor colors shall be black (hot), white (neutral), and green (ground).
- 5. Furnish wire on spools.

B. Single Twisted Shielded Instrumentation Cable above 24 V:

- 1. Wire size shall be a minimum **No. 18** AWG, or as required based on the distances of the wire and permissible voltage drops.
- 2. Conductors shall be a twisted, 7/24 soft annealed copper strand with a 2- to 2.5-inch (50- to 65-mm) lay.
- 3. Conductor insulation shall have a Type THHN/THWN or Type TFN rating.
- 4. Shielding shall be 100 percent type, 0.35/0.5-mil aluminum/Mylar tape, helically applied with 25 percent overlap, and aluminum side in with tinned copper drain wire.
- 5. Outer jacket insulation shall have a 600-V, 90-deg C rating and shall be Type TC cable.
- 6. For twisted pair, conductor colors shall be black and white. For twisted triad, conductor colors shall be black, red and white.

7. Furnish wire on spools.

C. Single Twisted Shielded Instrumentation Cable 24 V and Less:

1. Wire size shall be a minimum **No. 20 AWG**, or as required based on the distances of the wire and permissible voltage drops.
2. Conductors shall be a twisted, 7/24 soft annealed copper stranding with a 2- to 2.5-inch (50- to 65-mm) lay.
3. Conductor insulation shall have a nominal 15-mil thickness, constructed from flame-retardant PVC.
4. Shielding shall be 100 percent type, 1.35-mil aluminum/polymer tape, helically applied with 25 percent overlap, and aluminum side in with tinned copper drain wire.
5. Outer jacket insulation shall have a 300-V, 105-deg C rating and shall be Type PLTC cable.
6. For twisted pair, conductor colors shall be black and white. For twisted triad, conductor colors shall be black, red and white.
7. Furnish wire on spools.

D. LAN and Communication Cable: Comply with DDC system manufacturer requirements for network being installed.

1. Cable shall be plenum rated.
2. Cable shall comply with NFPA 70.
3. Cable shall have a unique color that is different from other cables used on Project.
4. Copper Cable for Ethernet Network:
 - a. 1000BASE-T, or 1000BASE-TX.
 - b. TIA/EIA 586, Category 6.
 - c. Minimum No. 22 AWG solid.
 - d. Shielded Twisted Pair (STP).
 - e. Thermoplastic insulated conductors, enclosed in a thermoplastic outer jacket, Class CMP as plenum rated.

2.25 RACEWAYS FOR CONTROL WIRING, CABLING, AND TUBING

A. Metal Conduits, Tubing, and Fittings:

1. Listing and Labeling: Metal conduits, tubing, and fittings shall be listed and labeled as defined in NFPA 70, by a qualified testing agency, and marked for intended location and application.
2. GRC: Comply with NEMA ANSI C80.1 and UL 6.
3. ARC: Comply with NEMA ANSI C80.5 and UL 6A.
4. IMC: Comply with NEMA ANSI C80.6 and UL 1242.
5. PVC-Coated Steel Conduit: PVC-coated rigid steel conduit.
 - a. Comply with NEMA RN 1.
 - b. Coating Thickness: 0.040 inch (1 mm), minimum.
6. EMT: Comply with NEMA ANSI C80.3 and UL 797.
7. FMC: Comply with UL 1; zinc-coated steel or aluminum.

8. LFMC: Flexible steel conduit with PVC jacket and complying with UL 360.
9. Fittings for Metal Conduit: Comply with NEMA ANSI FB 1 and UL 514B.
 - a. Conduit Fittings for Hazardous (Classified) Locations: Comply with UL 1203 and NFPA 70.
 - b. Fittings for EMT:
 - 1) Material: Steel, or die cast.
 - 2) Type: Setscrew or compression.
 - c. Expansion Fittings: PVC or steel to match conduit type, complying with UL 651, rated for environmental conditions where installed, and including flexible external bonding jumper.
 - d. Coating for Fittings for PVC-Coated Conduit: Minimum thickness of 0.040 inch (1 mm), with overlapping sleeves protecting threaded joints.
10. Joint Compound for IMC, GRC, or ARC: Approved, as defined in NFPA 70, by authorities having jurisdiction for use in conduit assemblies, and compounded for use to lubricate and protect threaded conduit joints from corrosion and to enhance their conductivity.

B. Metal Wireways:

1. Description: Sheet metal, complying with UL 870 and NEMA 250, unless otherwise indicated, and sized according to NFPA 70.
 - a. Metal wireways installed outdoors shall be listed and labeled as defined in NFPA 70, by a qualified testing agency, and marked for intended location and application.
2. Fittings and Accessories: Include covers, couplings, offsets, elbows, expansion joints, adapters, hold-down straps, end caps, and other fittings to match and mate with wireways as required for complete system.
3. Wireway Covers: Hinged, or Flanged-and-gasketed type unless otherwise indicated.
4. Finish: Manufacturer's standard enamel finish.

C. Surface Metal Raceways: Galvanized steel with snap-on covers complying with UL 5. Manufacturer's standard enamel.

2.26 FIBER-OPTIC CABLE, CONNECTORS, AND RACEWAY

A. Cables:

1. Performance Requirements:
 - a. Fiber: Multimode graded index. Core/cladding size shall be either 62.5/125 or 100/140 micrometers.
 - b. Numerical Aperture:
 - 1) 62.5/125 Micrometer Fiber: 0.275 plus or minus 0.015.
 - 2) 100/140 Micrometer Fiber: 0.29 plus or minus 0.015.
 - c. Maximum Attenuation:
 - 1) 850 nm: 6.0 dB/km.

- 2) 1300 nm: 5.0 dB/km.
 - d. Minimum Bandwidth Dispersion: 300 Mhz-km at 850 nm.
 - e. Core/Cladding Index Difference: 0.3 percent plus or minus 0.05 percent, measured using refractive rear field measurement procedure.
 - f. Color-code finished fibers for easy identification.
 - g. Splice Loss: Fibers shall be spliced together to form a longer fiber using a commercially available fiber splicing machine recommended by cable manufacturer. Maximum loss per fiber splice shall be 0.20 dB.
 - h. Connection: Fibers shall be connected using fiber-optic connectors. Nominal connector loss shall not be greater than 1 dB.
 - i. Fiber-optic cable shall be suitable for use with 100Base-FX or 100Base-SX standard (as applicable) as defined in IEEE 802.3.
2. Mechanical and Environmental Requirements:
- a. Tensile Strength: Fiber cable shall withstand a minimum tensile strength of 2700 N with maximum elongation of less than 0.5 percent.
 - b. Bending Radius: Minimum static bending radius for cable shall be 10 times outside diameter for non-armored cables and 20 times outside diameter for armored cables. Non-armored cables shall withstand being flexed at minimum static bending radius plus or minus 90 degrees for at least 20 cycles at 20 to 40 cycles per minute at 20 deg C. Armored cables shall withstand being flexed at minimum static bending radius plus or minus 90 degrees for at least 10 cycles at 20 to 40 cycles per minute at 20 deg C.
 - c. Vibration: Cable shall withstand a vibration test with vibration amplitude of 5 mm and frequency of 10 cycles per second for at least five hours.
 - d. Twist: Cable shall withstand twisting of 360 degrees over a length of 2 m for at least 10 cycles at 10 cycles per minute.
 - e. Temperature: Cable shall withstand the following temperatures:
 - 1) Installation: Minus 30 to 70 deg C.
 - 2) Operation: Minus 40 to 70 deg C.
 - 3) Storage/Shipping: Minus 40 to 70 deg C.
 - f. Lifetime: Average lifetime of a 2-km, 12-fiber cable shall be at least 20 years when installed in a natural ambient environment. End of useful life shall be reached if failing to comply with requirements indicated or a spontaneous catastrophic fiber failure.
 - g. Crush Resistance: Cable shall withstand a compressive force of 705 N/cm for armored cables and 600 N/cm for non-armored cables. There shall be no attenuation increase after force is removed.
3. Cable Structure:
- a. Number of Fibers: Supply the required number of fibers in each cable for DDC system indicated, plus not less than 50 percent spare. Cable structure shall have fibers grouped for easy handling.
 - b. Strength Members: Include cable with strength members to satisfy mechanical and environmental conditions indicated.
 - c. Cable Core: Core shall consist of stranded buffer tubes around a central member of appropriate geometric size and shall be filled and bound to maintain core integrity. A fibrous strength member may be stranded around core to provide necessary strength for cable.
 - d. Cable Jacket: Protect cable by an extruded-polyethylene jacket.

- e. Cable Armor: For cables requiring extra mechanical protection, one or two layers of galvanized corrugated steel tape coated by an anticorrosive compound shall be either helically or longitudinally applied over standard outer jacket. Apply a second outer jacket of polyethylene over coated steel tape. Thickness of sheaths and jackets are not specified as long as mechanical and environmental conditions are satisfied.
 - f. Cable Installation: Cables shall be suitable for a semiprotected outdoor installation.
4. Packaging and Shipping:
- a. Seal both ends of each length of cable.
 - b. Test individual fibers in each cable before shipping to verify compliance with Specifications.
- B. Connectors:
- 1. Performance Requirements:
 - a. Type: Fiber-optic connectors shall be either Type ST or Type SMA. Use either connector type exclusively. No substitutions are allowed.
 - b. Insertion Loss: Connector shall have an insertion loss of not greater than 1 dB.
 - c. Coupling Tolerance: Connector shall withstand at least 500 couplings with insertion loss within 0.25-dB tolerance limit.
 - d. Mechanical Requirements:
 - 1) Connector shall enclose outermost coating of single fiber cable and be able to be mated or unmated without using a tool.
 - 2) Mount connector rigidly in a metal frame.
 - 3) Connector shall allow a semiskilled person to properly install connector to a single fiber easily in a field environment with simple tools.
- C. Splice Organizer Cabinet:
- 1. Minimum Capacity: Each splice organizer shall accommodate number of connectors required for DDC system indicated, plus 100 percent spare.
 - 2. Mounting: Wall mount the splice organizer cabinet.
- D. Raceways:
- 1. Mechanical and Performance Requirements:
 - a. Construction: Nonmetallic, flexible raceway system manufactured specifically for routing fiber-optic cables.
 - b. Suitable for use in return-air plenums, air-handling rooms, above ceilings and under access floors.
 - c. Exhibit low smoke generation and flame-spread characteristics, and have high-temperature service tolerance.
 - d. Size raceway according to NFPA 70 requirements for communications cables.
 - e. Tensile Strength at Yield: 10,800 psi.
 - f. Elongation at Break: 25 percent.
- E. Cable Identification:
- 1. Labeling product shall be self-laminating cable marker.

2.27 CONTROL POWER WIRING AND RACEWAYS

- A. Comply with requirements in Section 16120 "Low-Voltage Electrical Power Conductors and Cables" electrical power conductors and cables.
- B. Comply with requirements in Section 16110 "Raceways and Boxes for Electrical Systems" for electrical power raceways and boxes.

2.28 ACCESSORIES

A. Damper Blade Limit Switches:

- 1. Sense positive open and/or closed position of the damper blades.
- 2. NEMA 250, Type 13, oil-tight construction.
- 3. Arrange for the mounting application.
- 4. Additional waterproof enclosure when required by its environment.
- 5. Arrange to prevent "over-center" operation.

B. Manual Valves:

- 1. Needle Type:
 - a. PTFE packing.
 - b. Construct of brass for use with copper and polyethylene tubing and of stainless steel for use with stainless-steel tubing.
 - c. Aluminum T-bar handle.
 - d. Include tubing connections.
- 2. Ball Type:
 - a. Body: Bronze ASTM B 62 or ASTM B 61.
 - b. Ball: Type 316 stainless steel.
 - c. Stem: Type 316 stainless steel.
 - d. Seats: Reinforced PTFE.
 - e. Packing Ring: Reinforced PTFE.
 - f. Lever: Stainless steel with a vinyl grip.
 - g. 600 WOG.
 - h. Threaded end connections.

2.29 IDENTIFICATION

A. Instrument Air Pipe and Tubing:

- 1. Engraved tag shall bear the following information:
 - a. Service (Example): "Instrument Air."
 - b. Pressure Range (Example): 0 to 30 psig (0 to 200 kPa).

2. Letter size shall be a minimum of 0.25 inch (6 mm) high.
3. Tag shall consist of white lettering on blue background.
4. Tag shall be engraved phenolic consisting of three layers of rigid laminate. Top and bottom layers are color-coded blue with contrasting white center exposed by engraving through outer layer.
5. Include tag with a brass grommet, chain and S-hook.

B. Control Equipment, Instruments, and Control Devices:

1. Engraved tag bearing unique identification.
 - a. Include instruments with unique identification identified by equipment being controlled or monitored, followed by point identification.
2. Letter size shall be as follows:
 - a. Operator Workstations: Minimum of 0.5 inch (13 mm) high.
 - b. Printers: Minimum of 0.5 inch (13 mm)] high.
 - c. DDC Controllers: Minimum of 0.5 inch (13 mm) high.
 - d. Gateways: Minimum of 0.5 inch (13 mm) high.
 - e. Repeaters: Minimum of 0.5 inch (13 mm) high.
 - f. Enclosures: Minimum of 0.5 inch (13 mm) high.
 - g. Electrical Power Devices: Minimum of 0.25 inch (6 mm) high.
 - h. UPS units: Minimum of 0.5 inch (13 mm) high.
 - i. Accessories: Minimum of 0.25 inch (6 mm) high.
 - j. Instruments: Minimum of 0.25 inch (6 mm) high.
 - k. Control Damper and Valve Actuators: Minimum of 0.25 inch (6 mm) high.
3. Tag shall consist of white lettering on black background.
4. Tag shall be engraved phenolic consisting of three layers of rigid laminate. Top and bottom layers are color-coded black with contrasting white center exposed by engraving through outer layer.
5. Tag shall be fastened with drive pins.
6. Instruments, control devices and actuators with Project-specific identification tags having unique identification numbers following requirements indicated and provided by original manufacturer do not require an additional tag.

C. Valve Tags:

1. Brass tags and brass chains attached to valve.
2. Tags shall be at least 1.5 inches (38 mm) in diameter.
3. Include tag with unique valve identification indicating control influence such as flow, level, pressure, or temperature; followed by location of valve, and followed by three-digit sequential number. For example: TV-1.001.
4. Valves with Project-specific identification tags having unique identification numbers following requirements indicated and provided by original manufacturer do not require an additional tag.

D. Raceway and Boxes:

1. Comply with requirements for identification specified in Section 16 "Identification for Electrical Systems."
2. Paint cover plates on junction boxes and conduit same color as the tape banding for conduits. After painting, label cover plate "HVAC Controls," using an engraved phenolic tag.
3. For raceways housing pneumatic tubing, add a phenolic tag labeled "HVAC Instrument Air Tubing."
4. For raceways housing air signal tubing, add a phenolic tag labeled "HVAC Air Signal Tubing."

E. Equipment Warning Labels:

1. Acrylic label with pressure-sensitive adhesive back and peel-off protective jacket.
2. Lettering size shall be at least 14-point type with white lettering on red background.
3. Warning label shall read "CAUTION-Equipment operated under remote automatic control and may start or stop at any time without warning. Switch electric power disconnecting means to OFF position before servicing."
4. Lettering shall be enclosed in a white line border. Edge of label shall extend at least 0.25 inch (6 mm) beyond white border.

2.30 SOURCE QUALITY CONTROL

- A. Product(s) **and** material(s) will be considered defective if they do not pass tests and inspections.
- B. Prepare test and inspection reports.

PART 3 - EXECUTION

3.1 EXAMINATION

- A. Examine substrates and conditions for compliance with requirements for installation tolerances and other conditions affecting performance of the Work.
 1. Verify compatibility with and suitability of substrates.
- B. Examine roughing-in for products to verify actual locations of connections before installation.
 1. Examine roughing-in for instruments installed in piping to verify actual locations of connections before installation.
 2. Examine roughing-in for instruments installed in duct systems to verify actual locations of connections before installation.
- C. Examine walls, floors, roofs, and ceilings for suitable conditions where product will be installed.

- D. Prepare written report, endorsed by Installer, listing conditions detrimental to performance of the Work.
- E. Proceed with installation only after unsatisfactory conditions have been corrected.

3.2 DDC SYSTEM INTERFACE WITH OTHER SYSTEMS AND EQUIPMENT

A. Communication Interface to Equipment with Integral Controls:

- 1. DDC system shall have communication interface with equipment having integral controls and having a communication interface for remote monitoring or control.
- 2. Equipment to Be Connected:
 - a. Domestic water booster pumps
 - b. Air-terminal units
 - c. Boilers
 - d. Hot Water pumps
 - e. Air-handling units
 - f. Computer-room air-conditioning units
 - g. Heat pumps
 - h. Fan-coil units
 - i. Motor-control centers
 - j. Variable-frequency controllers
 - k. Generator sets
 - l. Refrigerant monitoring.

3.3 CONTROL DEVICES FOR INSTALLATION BY INSTALLERS

- A. Deliver selected control devices, specified in indicated HVAC instrumentation and control device Sections, to identified equipment and systems manufacturers for factory installation and to identified installers for field installation.
- B. Deliver the following to duct fabricator and Installer for installation in ductwork. Include installation instructions to Installer and supervise installation for compliance with requirements.
 - 1. DDC control dampers,
 - 2. Airflow sensors and switches
 - 3. Pressure sensors,
- C. Deliver the following to plumbing and HVAC piping installers for installation in piping. Include installation instructions to Installer and supervise installation for compliance with requirements.
 - 1. DDC control valves,
 - 2. Pipe-mounted flow meters,
 - 3. Pipe-mounted sensors, switches and transmitters, flow meters.

4. Tank-mounted sensors, switches and transmitters. Pressure sensors, switches, and transmitters.

3.4 CONTROL DEVICES FOR EQUIPMENT MANUFACTURER FACTORY INSTALLATION

- A. Deliver the following to air-handling unit manufacturer for factory installation. Include installation instructions to air-handling unit manufacturer and supervise installation for compliance with requirements
 1. Programmable application or application-specific controller.
 2. Unit-mounted DDC control dampers and actuators,
 3. Unit-mounted airflow sensors, switches and transmitters,
 4. Unit-mounted gas sensors and transmitters,
 5. Unit-mounted speed sensors, switches and transmitters,
 6. Unit-mounted pressure sensors, switches and transmitters,
 7. Unit-mounted temperature sensors, switches and transmitters, air-temperature sensors, switches, and transmitters
 8. Relays.

- B. Deliver the following to terminal unit manufacturer for factory installation. Include installation instructions to terminal unit manufacturer.
 1. Programmable application, or application-specific controller.
 2. Electric damper actuator. Dampers actuators,
 3. Unit-mounted flow and pressure sensors, transmitters and transducers. Flow sensors, transmitters, and transducers,
 4. Pressure sensors, switches, and transmitters,
 5. Unit-mounted temperature sensors, air-temperature sensors, switches, and transmitters.
 6. Relays.

3.5 GENERAL INSTALLATION REQUIREMENTS

- A. Install products to satisfy more stringent of all requirements indicated.
- B. Install products level, plumb, parallel, and perpendicular with building construction.
- C. Support products, tubing, piping wiring and raceways. Brace products to prevent lateral movement and sway or a break in attachment when subjected to a force.
- D. If codes and referenced standards are more stringent than requirements indicated, comply with requirements in codes and referenced standards.
- E. Fabricate openings and install sleeves in ceilings, floors, roof, and walls required by installation of products. Before proceeding with drilling, punching, and cutting, check

for concealed work to avoid damage. Patch, flash, grout, seal, and refinish openings to match adjacent condition.

- F. Firestop penetrations made in fire-rated assemblies. Comply with requirements in Section 07841 "Penetration Firestopping."
- G. Seal penetrations made in acoustically rated assemblies. Comply with requirements in Section 07900 "Joint Sealants."
- H. Welding Requirements:
 - 1. Restrict welding and burning to supports and bracing.
 - 2. No equipment shall be cut or welded without approval. Welding or cutting will not be approved if there is risk of damage to adjacent Work.
 - 3. Welding, where approved, shall be by inert-gas electric arc process and shall be performed by qualified welders according to applicable welding codes.
 - 4. If requested on-site, show satisfactory evidence of welder certificates indicating ability to perform welding work intended.
- I. Fastening Hardware:
 - 1. Stillson wrenches, pliers, and other tools that damage surfaces of rods, nuts, and other parts are prohibited for work of assembling and tightening fasteners.
 - 2. Tighten bolts and nuts firmly and uniformly. Do not overstress threads by excessive force or by oversized wrenches.
 - 3. Lubricate threads of bolts, nuts and screws with graphite and oil before assembly.
- J. If product locations are not indicated, install products in locations that are accessible and that will permit service and maintenance from floor, equipment platforms, or catwalks without removal of permanently installed furniture and equipment.
- K. Corrosive Environments:
 - 1. Avoid or limit use of materials in corrosive airstreams and environments, including, but not limited to, the following:
 - a. Laboratory exhaust-air streams.
 - b. Process exhaust-air streams.
 - 2. When conduit is in contact with a corrosive airstream and environment, use Type 316 stainless-steel conduit and fittings or conduit and fittings that are coated with a corrosive-resistant coating that is suitable for environment. Comply with requirements for installation of raceways and boxes specified in Section 16110 "Raceways and Boxes for Electrical Systems."
 - 3. Where instruments are located in a corrosive airstream and are not corrosive resistant from manufacturer, field install products in NEMA 250, Type 4X enclosure constructed of Type 316L stainless steel.

3.6 OPERATOR WORKSTATION INSTALLATION

A. Portable Operator Workstations Installation:

1. Turn over portable operator workstations to Owner at Substantial Completion.
2. Install software on workstation(s) and verify software functions properly.

B. Color Graphics Application:

1. Use system schematics indicated as starting point to create graphics.
2. Develop Project-specific library of symbols for representing system equipment and products.
3. Incorporate digital images of Project-completed installation into graphics where beneficial to enhance effect.
4. Submit sketch of graphic layout with description of all text for each graphic for Owner's and Engineer's review before creating graphic using graphics software.
5. Seek Owner input in graphics development once using graphics software.
6. Final editing shall be done on-site with Owner's and Engineer's review and feedback.
7. Refine graphics as necessary for Owner acceptance.
8. On receiving Owner acceptance, print a hard copy for inclusion in operation and maintenance manual. Prepare a scanned copy PDF file of each graphic and include with softcopy of DDC system operation and maintenance manual.

3.7 POT INSTALLATION

A. Install 1 portable operator terminal(s).

B. Turn over POTs to Owner at Substantial Completion.

C. Install software on each POT and verify that software functions properly.

3.8 PRINTER INSTALLATION

A. Provide the following printer(s) at location(s) directed by Owner:

1. Color Inkjet: Quantity, 1.
2. Dot Matrix: Quantity, 1

B. Install printer software on workstations and verify that software functions properly.

3.9 GATEWAY INSTALLATION

A. Install gateways if required for DDC system communication interface requirements indicated.

1. Install gateway(s) required to suit indicated requirement.

B. Test gateway to verify that communication interface functions properly.

3.10 ROUTER INSTALLATION

- A. Install routers if required for DDC system communication interface requirements indicated.
 - 1. Install router(s) required to suit indicated requirement
- B. Test router to verify that communication interface functions properly.

3.11 CONTROLLER INSTALLATION

- A. Install controllers in enclosures to comply with indicated requirements.
- B. Connect controllers to field power supply and backup power as required.
- C. Install controller with latest version of applicable software and configure to execute requirements indicated.
- D. Test and adjust controllers to verify operation of connected I/O to achieve performance indicated requirements while executing sequences of operation.
- E. Installation of Network Controllers:
 - 1. Quantity and location of network controllers shall be determined by DDC system manufacturer to satisfy requirements indicated.
 - 2. Install controllers in a protected location that is easily accessible by operators.
 - 3. Top of controller shall be within 72 inches (1800 mm) of finished floor.
- F. Installation of Programmable Application Controllers:
 - 1. Quantity and location of programmable application controllers shall be determined by DDC system manufacturer to satisfy requirements indicated.
 - 2. Install controllers in a protected location that is easily accessible by operators.
 - 3. Top of controller shall be within 72 inches (1800 mm) of finished floor.
- G. Application-Specific Controllers:
 - 1. Quantity and location of application-specific controllers shall be determined by DDC system manufacturer to satisfy requirements indicated.
 - 2. For controllers not mounted directly on equipment being controlled, install controllers in a protected location that is easily accessible by operators.

3.12 ENCLOSURES INSTALLATION

- A. Install the following items in enclosures, to comply with indicated requirements:
 - 1. Gateways.
 - 2. Routers.
 - 3. Controllers.
 - 4. Electrical power devices.

5. UPS
6. Relays.
7. Accessories.
8. Instruments.
9. Actuators

B. Attach wall-mounted enclosures to wall using the following types of steel struts:

1. For NEMA 250, Type 1 Enclosures: Use painted steel indoors, strut and hardware.
2. For NEMA 250, Type 4 Enclosures and Enclosures Located Outdoors: Use stainless-steel strut and hardware.
3. Install plastic caps on exposed cut edges of strut.

C. Align top or bottom of adjacent enclosures of like size

D. Install floor-mounted enclosures located in mechanical equipment rooms on concrete housekeeping pads. Attach enclosure legs using galvanized- or stainless-steel anchors.

E. Install continuous and fully accessible wireways to connect conduit, wire, and cable to multiple adjacent enclosures. Wireway used for application shall have protection equal to NEMA 250 rating of connected enclosures.

3.13 ELECTRIC POWER CONNECTIONS

A. Connect electrical power to DDC system products requiring electrical power connections.

B. Design of electrical power to products not indicated with electric power is delegated to DDC system provider and installing trade. Work shall comply with NFPA 70 and other requirements indicated.

C. Comply with requirements in Section 16120 "Low-Voltage Electrical Power Conductors and Cables" for electrical power conductors and cables.

D. Comply with requirements in Section 16110 "Raceways and Boxes for Electrical Systems" for electrical power raceways and boxes.

3.14 IDENTIFICATION

A. Identify system components, wiring, cabling, and terminals. Comply with requirements in Section 16052 "Identification for Electrical Systems" for identification products and installation.

B. Install engraved phenolic nameplate with unique identification on face for each of the following:

1. Operator workstation.

2. Printer.
 3. Gateway.
 4. Router.
 5. DDC controller.
 6. Enclosure.
 7. Electrical power device.
 8. UPS unit.
 9. Accessory.
- C. Install engraved phenolic nameplate with unique instrument identification on face of each instrument connected to a DDC controller.
- D. Install engraved phenolic nameplate with identification on face of each control damper, and valve actuator connected to a DDC controller.
- E. Where product is installed above accessible tile ceiling, also install matching engraved phenolic nameplate with identification on face of ceiling grid located directly below.
- F. Where product is installed above an inaccessible ceiling, also install engraved phenolic nameplate with identification on face of access door directly below.
- G. Warning Labels:
1. Shall be permanently attached to equipment that can be automatically started by DDC control system.
 2. Shall be located in highly visible location near power service entry points.

3.15 NETWORK INSTALLATION

- A. Install copper cable when connecting between the following network devices [**located in same building**]:
1. Operator workstations.
 2. Operator workstations and network controllers.
 3. Network controller.
- B. Install copper cable when connecting between the following:
1. Gateways.
 2. Gateways and network controllers or programmable application controllers.
 3. Routers.
 4. Routers and network controllers or programmable application controllers.
 5. Network controllers and programmable application controllers.
 6. Programmable application controllers.
 7. Programmable application controllers and application-specific controllers.
 8. Application-specific controllers.
- C. Install network cable in continuous raceway.

1. Where indicated on Drawings, cable trays may be used for copper cable in lieu of conduit.

3.16 NETWORK NAMING AND NUMBERING

- A. Coordinate with Owner and provide unique naming and addressing for networks and devices.
- B. ASHRAE 135 Networks:
 1. MAC Address:
 - a. Every network device shall have an assigned and documented MAC address unique to its network.
 - b. Ethernet Networks: Document MAC address assigned at its creation.
 - c. ARCNET or MS/TP networks: Assign from 00 to 64.
 2. Network Numbering:
 - a. Assign unique numbers to each new network.
 - b. Provide ability for changing network number through device switches or operator interface.
 - c. DDC system, with all possible connected LANs, can contain up to 65,534 unique networks.
 3. Device Object Identifier Property Number:
 - a. Assign unique device object identifier property numbers or device instances for each device network.
 - b. Provide for future modification of device instance number by device switches or operator interface.
 - c. LAN shall support up to 4,194,302 unique devices.
 4. Device Object Name Property Text:
 - a. Device object name property field shall support 32 minimum printable characters.
 - b. Assign unique device "Object Name" property names with plain-English descriptive names for each device.
 - 1) Example 1: Device object name for device controlling boiler plant at Building 1000 would be "HW System B1000."
 - 2) Example 2: Device object name for a VAV terminal unit controller could be "VAV unit 102".
 5. Object Name Property Text for Other Than Device Objects:
 - a. Object name property field shall support 32 minimum printable characters.
 - b. Assign object name properties with plain-English names descriptive of application.

- 1) Example 1: "Zone 1 Temperature."
- 2) Example 2 "Fan Start and Stop."

6. Object Identifier Property Number for Other Than Device Objects:

- a. Assign object identifier property numbers according to Drawing, or tables indicated.
- b. If not indicated, object identifier property numbers may be assigned at Installer's discretion but must be approved by Owner in advance, be documented and be unique for like object types within device.

3.17 PIPING AND TUBING INSTALLATION

A. Above-Grade Pneumatic and Air Signal Piping and Tubing Installation:

1. Material Application:

- a. Install copper tubing, except as follows:
 - 1) Tubing Exposed to View: copper tubing installed in raceways may be used in lieu of copper tubing.
 - 2) Concealed Tubing: install copper tubing when concealed behind accessible ceilings, and concealed in walls and connecting wall-mounted instruments with recessed connections.
- b. Install copper tubing for air signals to instruments including, but not limited to, the following:
 - 1) Sensors.
 - 2) Switches.
 - 3) Transmitters.
 - 4) Transducers.
- c. Install drawn-temper copper tubing, except within 36 inches (900 mm) of device terminations tubing shall be annealed-tempered copper tubing.
- d. Install compression fittings to connect copper tubing to instruments, control devices, and accessories.
- e. Install barbed, or compression fittings to connect polyethylene tubing to instruments, control devices, and accessories.

2. Routing:

- a. Do not expose tubing in finished spaces, such as spaces with ceilings; occupied spaces, offices, and conference rooms, unless expressly approved in writing by Architect. Tubing may be exposed in areas without ceilings.
- b. Where tubing is installed in finished occupied spaces, install the tubing in surface metal raceway with appropriate fittings only where not feasible to conceal in wall, above ceiling or behind architectural enclosures or covers.

- c. Install piping and tubing plumb and parallel to and at right angles with building construction.
 - d. Install multiple runs of tubing or piping in equally spaced parallel lines.
 - e. Piping and tubing shall not interfere with access to valves, equipment, duct and equipment access doors, or obstruct personnel access and passageways of any kind.
 - f. Coordinate with other trades before installation to prevent proposed piping and tubing from interfering with pipe, duct, terminal equipment, light fixtures, conduit and cable tray space. If changes to Shop Drawings are necessary due to field coordination, document changes on record Drawings.
 - g. Install vibration loops in copper tubing when connecting to instrument and actuators that vibrate.
3. Support:
- a. According to MSS SP-69, Table 3, except support spacing shall not exceed 60 inches (1500 mm).
 - b. Support copper tubing with copper hangers, clips, and tube trays.
 - c. Do not use tape for support or dielectric isolation.
 - d. Install supports at each change in direction and at each branch take off.
 - e. Attached supports to building structure independent of work of other trades. Support from ducts, pipes, cable trays, and conduits is prohibited.
 - f. Attached support from building structure with threaded rods, structural shapes, or channel strut.
 - g. Install and brace supports to carry static load plus a safety margin, which will allow tubing to be serviced.
 - h. Brace supports to prevent lateral movement.
 - i. Paint steel support members that are not galvanized or zinc coated.
 - j. Support polyethylene tubing same as copper tubing.
4. Do not attach piping and tubing to equipment that may be removed frequently for maintenance or that may impart vibration and expansion from temperature change.
5. Protect exposed tubing in mechanical equipment rooms from mechanical damage within 96 inches (2400 mm) above floor. Use aluminum channel reversed and secured over tubing to protect tubing from damage.
6. Joining and Makeup:
- a. Where joining and mating dissimilar metals where galvanic action could occur, install dielectric isolation.
 - b. Install a dirt leg with an isolation valve and threaded plug at each main air, connection to a panel, pneumatic pilot positioner and PRV station.
 - c. Make threaded joints for connecting to instrument equipment with connectors with a compression tubing connector on one end and threaded connection on other end.
 - d. Make tubing bends with a tube-bending tool. Hard bends, wrinkled or flattened bends are unacceptable.
 - e. Install tube fittings according to manufacturer's written instructions.
 - f. Do not make tubing connections to a fitting before completing makeup of the connection.

- g. Align tubing with the fitting. Avoid springing tube into position, as this may result in excessive stress on both tubing and fitting with possible resulting leaks.
 - h. Do not install fittings close to a bend. A length of straight tubing, not deformed by bending, is required for a proper connection.
 - i. Check tubing for correct diameter and wall thickness.
 - j. Tube ends shall be cut square and deburred. Exercise care during cutting to keep tubing round.
 - k. Thread pipe on a threading machine. Ream inner edges of pipe ends, file and grind to remove burrs.
 - l. Wrap pipe threads of fittings on pneumatic lines with a single wrap of PTFE tape.
 - m. Protect piping and tubing from entrance of foreign matter.
7. Conduit in which nonmetallic tubing is installed shall not exceed 50 percent fill. Support conduit according to NFPA 70 unless otherwise indicated.

B. Identify piping and tubing as follows:

1. Every 50 feet (15 m) of straight run.
2. At least once for each branch within 36 inches (900 mm) of main tee.
3. At each change in direction.
4. Within 36 inches (900 mm) of each ceiling, floor, roof and wall penetration.
5. Where exposed to and where concealed from view, including above ceiling plenums, shafts, and chases.
6. At each valve.
7. Mark each instrument tube connection with a number-coded identification. Each unique tube shall have same unique number at instrument connection and termination at opposite end of tube.

C. Isolation Valves Installation:

1. Install valves full size of piping and tubing.
2. Install at the following locations:
 - a. At each branch.
 - b. Before and after each PRV.
 - c. Before and after each air dryer.
 - d. At each control device.
3. Valves shall be located to be readily accessible from floor.

D. Process Tubing Installation:

1. Install process tubing for signal to instruments in liquid and steam systems. Instruments include, but are not limited to, the following:
 - a. Meters.
 - b. Sensors.
 - c. Switches.

d. Transmitters.

2. Support tubing according to MSS SP-69, Table 3, but at intervals no less than **60 inches (1500 mm)**.
3. Install NPS 1/2 (DN 15) process tubing for industrial-grade sensors, transmitters, and switches. Install stainless-steel bushings where required.
4. Make tubing bends with a bending tool. Flattened or wrinkled bends are unacceptable.
5. Support tubing independent of other trades.
6. Route tubing parallel to and at right angles to building construction.
7. Install tubing concealed in areas with ceilings.
8. Install a dirt leg with an isolation valve and threaded plug in drain valve at each connection to a transmitter and switch.
9. Insulate process piping connected to hot water systems for personnel protection if the surface temperature exceeds 120 deg F (49 deg C). Only insulate piping within maintenance personnel reach from floor, platform, or catwalk.
10. Wrap pipe threads of fitting in process tubing with service temperatures below 350 deg F (177 deg C) with a single wrap of PTFE tape.
11. Coat pipe threads of fittings on process tubing in services with temperatures exceeding 350 deg F (177 deg C) with pipe compound before being made up to reduce the possibility of galling.
12. Do not make tubing connections to a fitting before completing makeup of the connection.
13. Check tubing for correct diameter and wall thickness. Cut the tube ends square and deburred. Exercise care during cutting to keep tubing round.
14. Do not install fittings close to a bend. A length of straight tubing, not deformed by bending, is required for a proper connection.
15. Align tubing with fitting when installed. Avoid springing tube into position.
16. Install tubing with extreme care exercised to keep foreign matter out of system. Open tubing ends shall be kept plugged to keep out dust, dirt and moisture.
17. Do not attach tubing to equipment that may be removed frequently for maintenance or may impart vibration and expansion from temperature change.
18. Protect exposed tubing in mechanical equipment rooms from inadvertent mechanical damage within 96 inches (2400 mm) above floor. Use aluminum channel reversed and secured over tubing to protect tubing from damage.

E. Isolation Valves Installation:

1. Install valves full size of piping and tubing.
2. Install isolation valves at the following locations:
 - a. Process connection.
 - b. Inlet to each instrument including, sensors, transmitters, switches, gages, and other control devices.
3. Locate valves to be readily accessible from floor.

3.18 CONTROL WIRE, CABLE AND RACEWAYS INSTALLATION

- A. Comply with NECA 1.
- B. Comply with TIA 568-C.1.
- C. Wiring Method: Install cables in raceways and cable trays except in accessible ceiling spaces and in gypsum board partitions where unenclosed wiring method may be used. Conceal raceway and cables except in unfinished spaces.
 - 1. Install plenum cable in environmental air spaces, including plenum ceilings.
 - 2. Comply with requirements for raceways and boxes specified in Section 16110 "Raceways and Boxes for Electrical Systems."
- D. Wiring Method: Conceal conductors and cables in accessible ceilings, walls, and floors where possible.
- E. Field Wiring within Enclosures: Bundle, lace, and train conductors to terminal points with no excess and without exceeding manufacturer's limitations on bending radii. Install lacing bars and distribution spools.
- F. Conduit Installation:
 - 1. Install conduit expansion joints where conduit runs exceed 200 feet (60 m), and conduit crosses building expansion joints.
 - 2. Coordinate conduit routing with other trades to avoid conflicts with ducts, pipes and equipment and service clearance.
 - 3. Maintain at least 3-inch (75-mm) separation where conduits run axially above or below ducts and pipes.
 - 4. Limit above-grade conduit runs to 100 feet (30 m) without pull or junction box.
 - 5. Do not install raceways or electrical items on any "explosion-relief" walls, or rotating equipment.
 - 6. Do not fasten conduits onto the bottom side of a metal deck roof.
 - 7. Flexible conduit is permitted only where flexibility and vibration control is required.
 - 8. Limit flexible conduit to 3 feet (1 m) long.
 - 9. Conduit shall be continuous from outlet to outlet, from outlet to enclosures, pull and junction boxes, and shall be secured to boxes in such manner that each system shall be electrically continuous throughout.
 - 10. Direct bury conduits underground or install in concrete-encased duct bank where indicated.
 - a. Use rigid, nonmetallic, Schedule 80 PVC.
 - b. Provide a burial depth according to NFPA 70, but not less than 24 inches (600 mm).
 - 11. Secure threaded conduit entering an instrument enclosure, cabinet, box, and trough, with a locknut on outside and inside, such that conduit system is electrically continuous throughout. Provide a metal bushing on inside with

insulated throats. Locknuts shall be the type designed to bite into the metal or, on inside of enclosure, shall have a grounding wedge lug under locknut.

12. Conduit box-type connectors for conduit entering enclosures shall have an insulated throat.
13. Connect conduit entering enclosures in wet locations with box-type connectors or with watertight sealing locknuts or other fittings.
14. Offset conduits where entering surface-mounted equipment.
15. Seal conduit runs used by sealing fittings to prevent the circulation of air for the following:
 - a. Conduit extending from interior to exterior of building.
 - b. Conduit extending into pressurized duct and equipment.
 - c. Conduit extending into pressurized zones that are automatically controlled to maintain different pressure set points.

G. Wire and Cable Installation:

1. Cables serving a common system may be grouped in a common raceway. Install control wiring and cable in separate raceway from power wiring. Do not group conductors from different systems or different voltages.
2. Install cables with protective sheathing that is waterproof and capable of withstanding continuous temperatures of 90 deg C with no measurable effect on physical and electrical properties of cable.
 - a. Provide shielding to prevent interference and distortion from adjacent cables and equipment.
3. Install lacing bars to restrain cables, to prevent straining connections, and to prevent bending cables to smaller radii than minimums recommended by manufacturer.
4. Bundle, lace, and train conductors to terminal points without exceeding manufacturer's limitations on bending radii, but not less than radii specified in BICSI ITSIMM, "Cabling Termination Practices" Chapter. Install lacing bars and distribution spools.
5. UTP Cable Installation:
 - a. Comply with TIA 568-C.2.
 - b. Do not untwist UTP cables more than 1/2 inch (12 mm) from the point of termination, to maintain cable geometry.
6. Identify each wire on each end and at each terminal with a number-coded identification tag. Each wire shall have a unique tag.
7. Provide strain relief.
8. Terminate wiring in a junction box.
 - a. Clamp cable over jacket in junction box.
 - b. Individual conductors in the stripped section of the cable shall be slack between the clamping point and terminal block.

9. Terminate field wiring and cable not directly connected to instruments and control devices having integral wiring terminals using terminal blocks.
10. Install signal transmission components according to IEEE C2, REA Form 511a, NFPA 70, and as indicated.
11. Keep runs short. Allow extra length for connecting to terminal boards. Do not bend flexible coaxial cables in a radius less than 10 times the cable OD. Use sleeves or grommets to protect cables from vibration at points where they pass around sharp corners and through penetrations.
12. Ground wire shall be copper and grounding methods shall comply with IEEE C2. Demonstrate ground resistance.
13. Wire and cable shall be continuous from terminal to terminal without splices.
14. Use insulated spade lugs for wire and cable connection to screw terminals.
15. Use shielded cable to transmitters.
16. Use shielded cable to temperature sensors.
17. Perform continuity and meager testing on wire and cable after installation.
18. Do not install bruised, kinked, scored, deformed, or abraded wire and cable. Remove and discard wire and cable if damaged during installation, and replace it with new cable.
19. Cold-Weather Installation: Bring cable to room temperature before dereeling. Heat lamps shall not be used for heating.
20. Pulling Cable: Comply with BICSI ITSIM, Ch. 4, "Pulling Cable." Monitor cable pull tensions.
21. Protection from Electro-Magnetic Interference (EMI): Provide installation free of (EMI). As a minimum, comply with the following requirements:
 - a. Comply with BICSI TDMM and TIA 569-C for separating unshielded cable from potential EMI sources, including electrical power lines and equipment.
 - b. Separation between open cables or cables in nonmetallic raceways and unshielded power conductors and electrical equipment shall be as follows:
 - 1) Electrical Equipment Rating Less Than 2 kVA: A minimum of 5 inches (127 mm).
 - 2) Electrical Equipment Rating between 2 and 5 kVA: A minimum of 12 inches (300 mm).
 - 3) Electrical Equipment Rating More Than 5 kVA: A minimum of 24 inches (610 mm).
 - c. Separation between cables in grounded metallic raceways and unshielded power lines or electrical equipment shall be as follows:
 - 1) Electrical Equipment Rating Less Than 2 kVA: A minimum of 2-1/2 inches (64 mm).
 - 2) Electrical Equipment Rating between 2 and 5 kVA: A minimum of 6 inches (150 mm).
 - 3) Electrical Equipment Rating More Than 5 kVA: A minimum of 12 inches (300 mm).
 - d. Separation between cables in grounded metallic raceways and power lines and electrical equipment located in grounded metallic conduits or enclosures shall be as follows:

- 1) Electrical Equipment Rating Less Than 2 kVA: No requirement.
 - 2) Electrical Equipment Rating between 2 and 5 kVA: A minimum of 3 inches (76 mm).
 - 3) Electrical Equipment Rating More Than 5 kVA: A minimum of 6 inches (150 mm).
- e. Separation between Cables and Electrical Motors and Transformers, 5 kVA or 5 HP and Larger: A minimum of 48 inches (1200 mm).
 - f. Separation between Cables and Fluorescent Fixtures: A minimum of 5 inches (127 mm).

3.19 FIBER-OPTIC CABLESYSTEM INSTALLATION

- A. Comply with TIA 568-C.3, except where requirements indicated are more stringent.

3.20 QUALITY CONTROL

- A. Manufacturer's Field Service: Engage a factory-authorized service representative to test and inspect components, assemblies, and installations, including connections.
- B. Perform the following tests and inspections with the assistance of a factory-authorized service representative:
 1. Perform each visual and mechanical inspection and electrical test stated in NETA Acceptance Testing Specification. Certify compliance with test parameters.
 2. Test and adjust controls and safeties. Replace damaged and malfunctioning controls and equipment.
 3. Testing of Pneumatic and Air-Signal Tubing:
 - a. Test for leaks and obstructions.
 - b. Disconnect each pipe and tubing line before a test is performed, and blowout dust, dirt, trash, condensate and other foreign materials with compressed air. Use commercially pure compressed air or nitrogen as distributed in gas cylinders. Air from an oil-free compressor with an air dryer is an acceptable alternative for the test.
 - c. After foreign matter is expelled and line is free from obstructions, plug far end of tubing run.
 - d. Connect a pressure source to near end of run with a needle valve between air supply and tubing run.
 - e. Connect a pressure gage accurate to within 0.5 percent of test between the shutoff needle valve and tubing run under test.
 - f. For system pressures above 30 psig (207 kPa), apply a pressure of 1.5 times operating pressure. Record pressure in tubing run every 10 minutes for one hour. Allowable drop in pressure in one-hour period shall not exceed 1 psig (6.9 kPa).
 - g. For system pressures 30 psig (207 kPa) and below, apply a pressure of 2.0 times operating pressure to piping and tubing run. Record pressure in tubing

run every 5 minutes for one hour. Allowable drop in pressure in one-hour period shall not exceed 0.5 psig (3.5 kPa).

C. Testing:

1. Perform preinstallation, in-progress, and final tests, supplemented by additional tests, as necessary.
2. Preinstallation Cable Verification: Verify integrity and serviceability for new cable lengths before installation. This assurance may be provided by using vendor verification documents, testing, or other methods. As a minimum, furnish evidence of verification for cable attenuation and bandwidth parameters.
3. In-Progress Testing: Perform standard tests for correct pair identification and termination during installation to ensure proper installation and cable placement. Perform tests in addition to those specified if there is any reason to question condition of material furnished and installed. Testing accomplished is to be documented by agency conducting tests. Submit test results for Project record.
4. Final Testing: Perform final test of installed system to demonstrate acceptability as installed. Testing shall be performed according to a test plan supplied by DDC system manufacturer. Defective Work or material shall be corrected and retested. As a minimum, final testing for cable system, including spare cable, shall verify conformance of attenuation, length, and bandwidth parameters with performance indicated.
5. Test Equipment: Use a fiber-optic time domain reflectometer for testing of length and optical connectivity.
6. Test Results: Record test results and submit copy of test results for Project record.

3.21 DDC SYSTEM I/O CHECKOUT PROCEDURES

- A. Check installed products before continuity tests, leak tests and calibration.
- B. Check instruments for proper location and accessibility.
- C. Check instruments for proper installation on direction of flow, elevation, orientation, insertion depth, or other applicable considerations that will impact performance.
- D. Check instrument tubing for proper isolation, fittings, slope, dirt legs, drains, material and support.
- E. For pneumatic products, verify that air supply for each product is properly installed.
- F. Control Damper Checkout:
 1. Verify that control dampers are installed correctly for flow direction.
 2. Verify that proper blade alignment, either parallel or opposed, has been provided.
 3. Verify that damper frame attachment is properly secured and sealed.
 4. Verify that damper actuator and linkage attachment is secure.
 5. Verify that actuator wiring is complete, enclosed and connected to correct power source.
 6. Verify that damper blade travel is unobstructed.

G. Control Valve Checkout:

1. For pneumatic valves, verify that pressure gages are provided in each air line to valve actuator and positioner.
2. Verify that control valves are installed correctly for flow direction.
3. Verify that valve body attachment is properly secured and sealed.
4. Verify that valve actuator and linkage attachment is secure.
5. Verify that actuator wiring is complete, enclosed and connected to correct power source.
6. Verify that valve ball, disc or plug travel is unobstructed.
7. After piping systems have been tested and put into service, but before insulating and balancing, inspect each valve for leaks. Adjust or replace packing to stop leaks. Replace the valve if leaks persist.

H. Instrument Checkout:

1. Verify that instrument is correctly installed for location, orientation, direction and operating clearances.
2. Verify that attachment is properly secured and sealed.
3. Verify that conduit connections are properly secured and sealed.
4. Verify that wiring is properly labeled with unique identification, correct type and size and is securely attached to proper terminals.
5. Inspect instrument tag against approved submittal.
6. For instruments with tubing connections, verify that tubing attachment is secure and isolation valves have been provided.
7. For flow instruments, verify that recommended upstream and downstream distances have been maintained.
8. For temperature instruments:
 - a. Verify sensing element type and proper material.
 - b. Verify length and insertion.

3.22 DDC SYSTEM I/O ADJUSTMENT, CALIBRATION AND TESTING:

- A. Calibrate each instrument installed that is not factory calibrated and provided with calibration documentation.
- B. Provide a written description of proposed field procedures and equipment for calibrating each type of instrument. Submit procedures before calibration and adjustment.
- C. For each analog instrument, make a three-point test of calibration for both linearity and accuracy.
- D. Equipment and procedures used for calibration shall comply with instrument manufacturer's written instructions.
- E. Provide diagnostic and test equipment for calibration and adjustment.

- F. Field instruments and equipment used to test and calibrate installed instruments shall have accuracy at least twice the instrument accuracy being calibrated. An installed instrument with an accuracy of 1 percent shall be checked by an instrument with an accuracy of 0.5 percent.
- G. Calibrate each instrument according to instrument instruction manual supplied by manufacturer.
- H. If after calibration indicated performance cannot be achieved, replace out-of-tolerance instruments.
- I. Comply with field testing requirements and procedures indicated by ASHRAE's Guideline 11, "Field Testing of HVAC Control Components," in the absence of specific requirements, and to supplement requirements indicated.
- J. Analog Signals:
 - 1. Check analog voltage signals using a precision voltage meter at zero, 50, and 100 percent.
 - 2. Check analog current signals using a precision current meter at zero, 50, and 100 percent.
 - 3. Check resistance signals for temperature sensors at zero, 50, and 100 percent of operating span using a precision-resistant source.
- K. Digital Signals:
 - 1. Check digital signals using a jumper wire.
 - 2. Check digital signals using an ohmmeter to test for contact making or breaking.
- L. Control Dampers:
 - 1. Stroke and adjust control dampers following manufacturer's recommended procedure, from 100 percent open to 100 percent closed and back to 100 percent open.
 - 2. Stroke control dampers with pilot positioners. Adjust damper and positioner following manufacturer's recommended procedure, so damper is 100 percent closed, 50 percent closed and 100 percent open at proper air pressure.
 - 3. Check and document open and close cycle times for applications with a cycle time less than 30 seconds.
 - 4. For control dampers equipped with positive position indication, check feedback signal at multiple positions to confirm proper position indication.
- M. Control Valves:
 - 1. Stroke and adjust control valves following manufacturer's recommended procedure, from 100 percent open to 100 percent closed and back to 100 percent open.
 - 2. Stroke control valves with pilot positioners. Adjust valve and positioner following manufacturer's recommended procedure, so valve is 100 percent closed, 50 percent closed and 100 percent open at proper air pressures.

3. Check and document open and close cycle times for applications with a cycle time less than 30 seconds.
 4. For control valves equipped with positive position indication, check feedback signal at multiple positions to confirm proper position indication.
- N. Meters: Check sensors at zero, 50, and 100 percent of Project design values.
- O. Sensors: Check sensors at zero, 50, and 100 percent of Project design values.
- P. Switches: Calibrate switches to make or break contact at set points indicated.
- Q. Transmitters:
1. Check and calibrate transmitters at zero, 50, and 100 percent of Project design values.
 2. Calibrate resistance temperature transmitters at zero, 50, and 100 percent of span using a precision-resistant source.

3.23 DDC SYSTEM CONTROLLER CHECKOUT

- A. Verify power supply.
1. Verify voltage, phase and hertz.
 2. Verify that protection from power surges is installed and functioning.
 3. Verify that ground fault protection is installed.
 4. If applicable, verify if connected to UPS unit.
 5. If applicable, verify if connected to a backup power source.
 6. If applicable, verify that power conditioning units, transient voltage suppression and high-frequency noise filter units are installed.
- B. Verify that wire and cabling is properly secured to terminals and labeled with unique identification.
- C. Verify that spare I/O capacity is provided.

3.24 DDC CONTROLLER I/O CONTROL LOOP TESTS

- A. Testing:
1. Test every I/O point connected to DDC controller to verify that safety and operating control set points are as indicated and as required to operate controlled system safely and at optimum performance.
 2. Test every I/O point throughout its full operating range.
 3. Test every control loop to verify operation is stable and accurate.
 4. Adjust control loop proportional, integral and derivative settings to achieve optimum performance while complying with performance requirements indicated. Document testing of each control loop's precision and stability via trend logs.
 5. Test and adjust every control loop for proper operation according to sequence of operation.

6. Test software and hardware interlocks for proper operation. Correct deficiencies.
7. Operate each analog point at the following:
 - a. Upper quarter of range.
 - b. Lower quarter of range.
 - c. At midpoint of range.
8. Exercise each binary point.
9. For every I/O point in DDC system, read and record each value at operator workstation, at DDC controller and at field instrument simultaneously. Value displayed at operator workstation, at DDC controller and at field instrument shall match.
10. Prepare and submit a report documenting results for each I/O point in DDC system and include in each I/O point a description of corrective measures and adjustments made to achieve desired results.

3.25 DDC SYSTEM VALIDATION TESTS

- A. Perform validation tests before requesting final review of system. Before beginning testing, first submit Pretest Checklist and Test Plan.
- B. After approval of Test Plan, execute all tests and procedures indicated in plan.
- C. After testing is complete, submit completed test checklist.
- D. Pretest Checklist: Submit the following list with items checked off once verified:
 1. Detailed explanation for any items that are not completed or verified.
 2. Required mechanical installation work is successfully completed and HVAC equipment is working correctly.
 3. HVAC equipment motors operate below full-load amperage ratings.
 4. Required DDC system components, wiring, and accessories are installed.
 5. Installed DDC system architecture matches approved Drawings.
 6. Control electric power circuits operate at proper voltage and are free from faults.
 7. Required surge protection is installed.
 8. DDC system network communications function properly, including uploading and downloading programming changes.
 9. Using BACnet protocol analyzer, verify that communications are error free.
 10. Each controller's programming is backed up.
 11. Equipment, products, tubing, wiring cable and conduits are properly labeled.
 12. All I/O points are programmed into controllers.
 13. Testing, adjusting and balancing work affecting controls is complete.
 14. Dampers and actuators zero and span adjustments are set properly.
 15. Each control damper and actuator goes to failed position on loss of power.
 16. Valves and actuators zero and span adjustments are set properly.
 17. Each control valve and actuator goes to failed position on loss of power.
 18. Meter, sensor and transmitter readings are accurate and calibrated.
 19. Control loops are tuned for smooth and stable operation.
 20. View trend data where applicable.

21. Each controller works properly in standalone mode.
22. Safety controls and devices function properly.
23. Interfaces with fire-alarm system function properly.
24. Electrical interlocks function properly.
25. Operator workstations and other interfaces are delivered, all system and database software is installed, and graphic are created.
26. Record Drawings are completed.

E. Test Plan:

1. Prepare and submit a validation test plan including test procedures for performance validation tests.
2. Test plan shall address all specified functions of DDC system and sequences of operation.
3. Explain detailed actions and expected results to demonstrate compliance with requirements indicated.
4. Explain method for simulating necessary conditions of operation used to demonstrate performance.
5. Include a test checklist to be used to check and initial that each test has been successfully completed.
6. Submit test plan documentation 10 business days before start of tests.

F. Validation Test:

1. Verify operating performance of each I/O point in DDC system.
 - a. Verify analog I/O points at operating value.
 - b. Make adjustments to out-of-tolerance I/O points.
 - 1) Identify I/O points for future reference.
 - 2) Simulate abnormal conditions to demonstrate proper function of safety devices.
 - 3) Replace instruments and controllers that cannot maintain performance indicated after adjustments.
2. Simulate conditions to demonstrate proper sequence of control.
3. Readjust settings to design values and observe ability of DDC system to establish desired conditions.
4. After 24 Hours following Initial Validation Test:
 - a. Re-check I/O points that required corrections during initial test.
 - b. Identify I/O points that still require additional correction and make corrections necessary to achieve desired results.
5. After 24 Hours of Second Validation Test:
 - a. Re-check I/O points that required corrections during second test.
 - b. Continue validation testing until I/O point is normal on two consecutive tests.

6. Completely check out, calibrate, and test all connected hardware and software to ensure that DDC system performs according to requirements indicated.
7. After validation testing is complete, prepare and submit a report indicating all I/O points that required correction and how many validation re-tests it took to pass. Identify adjustments made for each test and indicate instruments that were replaced.

G. DDC System Response Time Test:

1. Simulate HLC.
 - a. Heavy load shall be an occurrence of 50 percent of total connected binary COV, one-half of which represent an "alarm" condition, and 50 percent of total connected analog COV, one-half of which represent an "alarm" condition, that are initiated simultaneously on a one-time basis.
2. Initiate 10 successive occurrences of HLC and measure response time to typical alarms and status changes.
3. Measure with a timer having at least 0.1-second resolution and 0.01 percent accuracy.
4. Purpose of test is to demonstrate DDC system, as follows:
 - a. Reaction to COV and alarm conditions during HLC.
 - b. Ability to update DDC system database during HLC.
5. Passing test is contingent on the following:
 - a. Alarm reporting at printer beginning no more than 2 seconds after the initiation (time zero) of HLC.
 - b. All alarms, both binary and analog, are reported and printed; none are lost.
 - c. Compliance with response times specified.
6. Prepare and submit a report documenting HLC tested and results of test including time stamp and print out of all alarms.

H. DDC System Network Bandwidth Test:

1. Test network bandwidth usage on all DDC system networks to demonstrate bandwidth usage under DDC system normal operating conditions and under simulated HLC.
2. To pass, none of DDC system networks shall use more than 70 percent of available bandwidth under normal and HLC operation.

3.26 FINAL REVIEW

- A. Submit written request to Architect and Construction Manager when DDC system is ready for final review. Written request shall state the following:
 1. DDC system has been thoroughly inspected for compliance with contract documents and found to be in full compliance.

2. DDC system has been calibrated, adjusted and tested and found to comply with requirements of operational stability, accuracy, speed and other performance requirements indicated.
 3. DDC system monitoring and control of HVAC systems results in operation according to sequences of operation indicated.
 4. DDC system is complete and ready for final review.
- B. Review by Engineer and Construction Manager shall be made after receipt of written request. A field report shall be issued to document observations and deficiencies.
- C. Take prompt action to remedy deficiencies indicated in field report and submit a second written request when all deficiencies have been corrected. Repeat process until no deficiencies are reported.
- D. Should more than two reviews be required, DDC system manufacturer and Installer shall compensate entity performing review for total costs, labor and expenses, associated with third and subsequent reviews. Estimated cost of each review shall be submitted and approved by DDC system manufacturer and Installer before making the review.
- E. Prepare and submit closeout submittals when no deficiencies are reported.
- F. A part of DDC system final review shall include a demonstration to parties participating in final review.
1. Provide staff familiar with DDC system installed to demonstrate operation of DDC system during final review.
 2. Provide testing equipment to demonstrate accuracy and other performance requirements of DDC system that is requested by reviewers during final review.
 3. Demonstration shall include, but not be limited to, the following:
 - a. Accuracy and calibration of 25% I/O points randomly selected by reviewers. If review finds that some I/O points are not properly calibrated and not satisfying performance requirements indicated, additional I/O points may be selected by reviewers until total I/O points being reviewed that satisfy requirements equals quantity indicated.
 - b. HVAC equipment and system hardwired and software safeties and life-safety functions are operating according to sequence of operation. A minimum of 25 % I/O points shall be randomly selected by reviewers. Additional I/O points may be selected by reviewers to discover problems with operation.
 - c. Correct sequence of operation after electrical power interruption and resumption after electrical power is restored for randomly selected HVAC systems.
 - d. Operation of randomly selected dampers and valves in normal-on, normal-off and failed positions.
 - e. Reporting of alarm conditions for randomly selected alarms, including different classes of alarms, to ensure that alarms are properly received by operators and operator workstations.
 - f. Trends, summaries, logs and reports set-up for Project.

- g. For up to five HVAC systems randomly selected by reviewers, use graph trends to show that sequence of operation is executed in correct manner and that HVAC systems operate properly through complete sequence of operation including different modes of operations indicated. Show that control loops are stable and operating at set points and respond to changes in set point of 20 percent or more.
- h. Software's ability to communicate with controllers, operator workstations, uploading and downloading of control programs.
- i. Software's ability to edit control programs off-line.
- j. Data entry to show Project-specific customizing capability including parameter changes.
- k. Step through penetration tree, display all graphics, demonstrate dynamic update, and direct access to graphics.
- l. Execution of digital and analog commands in graphic mode.
- m. Spreadsheet and curve plot software and its integration with database.
- n. Online user guide and help functions.
- o. Multitasking by showing different operations occurring simultaneously on four quadrants of split screen.
- p. System speed of response compared to requirements indicated.
- q. For Each Network and Programmable Application Controller:
 - 1) Memory: Programmed data, parameters, trend and alarm history collected during normal operation is not lost during power failure.
 - 2) Operator Interface: Ability to connect directly to each type of digital controller with a portable operator workstation. Show that maintenance personnel interface tools perform as indicated in manufacturer's technical literature.
 - 3) Standalone Ability: Demonstrate that controllers provide stable and reliable standalone operation using default values or other method for values normally read over network.
 - 4) Electric Power: Ability to disconnect any controller safely from its power source.
 - 5) Wiring Labels: Match control drawings.
 - 6) Network Communication: Ability to locate a controller's location on network and communication architecture matches Shop Drawings.
 - 7) Nameplates and Tags: Accurate and permanently attached to control panel doors, instrument, actuators and devices.
- r. For Each Operator Workstation:
 - 1) I/O points lists agree with naming conventions.
 - 2) Graphics are complete.
 - 3) UPS unit, if applicable, operates.
- s. Communications and Interoperability: Demonstrate proper interoperability of data sharing, alarm and event management, trending, scheduling, and device and network management. Use ASHRAE 135 protocol analyzer to help identify devices, view network traffic, and verify interoperability. Requirements must be met even if only one manufacturer's equipment is installed.

- 1) Data Presentation: On each operator workstation, demonstrate graphic display capabilities.
- 2) Reading of Any Property: Demonstrate ability to read and display any used readable object property of any device on network.
- 3) Set Point and Parameter Modifications: Show ability to modify set points and tuning parameters indicated. Modifications are made with messages and write services initiated by an operator using workstation graphics, or by completing a field in a menu with instructional text.
- 4) Peer-to-Peer Data Exchange: Network devices are installed and configured to perform without need for operator intervention to implement Project sequence of operation and to share global data.
- 5) Alarm and Event Management: Alarms and events are installed and prioritized according to Owner. Demonstrate that time delays and other logic are set up to avoid nuisance tripping. Show that operators with sufficient privileges are permitted.
- 6) Schedule Lists: Schedules are configured for start and stop, mode change, occupant overrides, and night setback as defined in sequence of operations.
- 7) Schedule Display and Modification: Ability to display any schedule with start and stop times for calendar year. Show that all calendar entries and schedules are modifiable from any connected operator workstation by an operator with sufficient privilege.
- 8) Archival Storage of Data: Data archiving is handled by operator workstation and server and local trend archiving and display is accomplished.
- 9) Modification of Trend Log Object Parameters: Operator with sufficient privilege can change logged data points, sampling rate, and trend duration.
- 10) Device and Network Management:
 - a) Display of network device status.
 - b) Display of BACnet Object Information.
 - c) Silencing devices transmitting erroneous data.
 - d) Time synchronization.
 - e) Remote device re-initialization.
 - f) Backup and restore network device programming and master database(s).
 - g) Configuration management of route

3.27 ADJUSTING

- A. Occupancy Adjustments: When requested within 12 months from date of Substantial Completion, provide on-site assistance in adjusting system to suit actual occupied conditions. Provide up to Three visits to Project during other-than-normal occupancy hours for this purpose.

3.28 MAINTENANCE SERVICE

- A. Maintenance Service: Beginning at Substantial Completion, maintenance service shall include 12 months' full maintenance by DDC system manufacturer's authorized service representative. Include quarterly preventive maintenance, repair or replacement of worn or defective components, cleaning, calibration and adjusting as required for proper operation. Parts and supplies shall be manufacturer's authorized replacement parts and supplies.

3.29 SOFTWARE SERVICE AGREEMENT

- A. Technical Support: Beginning at Substantial Completion, service agreement shall include software support for 2 year(s).
- B. Upgrade Service: At Substantial Completion, update software to latest version. Install and program software upgrades that become available within 2 year(s) from date of Substantial Completion. Upgrading software shall include operating system and new or revised licenses for using software
 - 1. Upgrade Notice: At least 30 days to allow Owner to schedule and access system and to upgrade computer equipment if necessary.

3.30 DEMONSTRATION

- A. Engage a factory-authorized service representative with complete knowledge of Project-specific system installed to train Owner's maintenance personnel to adjust, operate, and maintain DDC system.
- B. Extent of Training:
 - 1. Base extent of training on scope and complexity of DDC system indicated and training requirements indicated. Provide extent of training required to satisfy requirements indicated even if more than minimum training requirements are indicated.
 - 2. Inform Owner of anticipated training requirements if more than minimum training requirements are indicated.
 - 3. Minimum Training Requirements:
 - a. Provide not less than 15 days of training total.
 - b. Stagger training over multiple training classes to accommodate Owner's requirements. All training shall occur before end of warranty period.
 - c. Total days of training shall be broken into not less than 3 separate training classes.
 - d. Each training class shall be not less than 2 consecutive day(s).
- C. Training Schedule:
 - 1. Schedule training with Owner 20 business days before expected Substantial Completion.

2. Schedule training to provide Owner with at least 10 business days of notice in advance of training.
3. Training shall occur within normal business hours at a mutually agreed on time. Unless otherwise agreed to, training shall occur Monday through Friday, except on U.S. Federal holidays, with two morning sessions and two afternoon sessions. Each morning session and afternoon session shall be split in half with 30-minute break between sessions. Morning and afternoon sessions shall be separated by 60 -minute lunch period. Training, including breaks and excluding lunch period, shall not exceed 8 hours per day.
4. Provide staggered training schedule as requested by Owner.

D. Training Attendee List and Sign-in Sheet:

1. Request from Owner in advance of training a proposed attendee list with name, phone number and e-mail address.
2. Provide a preprinted sign-in sheet for each training session with proposed attendees listed and no fewer than six blank spaces to add additional attendees.
3. Preprinted sign-in sheet shall include training session number, date and time, instructor name, phone number and e-mail address, and brief description of content to be covered during session. List attendees with columns for name, phone number, e-mail address and a column for attendee signature or initials.
4. Circulate sign-in sheet at beginning of each session and solicit attendees to sign or initial in applicable location.
5. At end of each training day, send Owner an e-mail with an attachment of scanned copy (PDF) of circulated sign-in sheet for each session.

E. Training Attendee Headcount:

1. Plan in advance of training for 2 attendees.
2. Make allowance for Owner to add up to 2 attendee(s) at time of training.
3. Headcount may vary depending on training content covered in session. Attendee access may be restricted to some training content for purposes of maintaining system security.

F. Training Attendee Prior Knowledge: For guidance in planning required training and instruction, assume attendees have the following:

1. High school and technical school, or High school and four-year college education and degree.
2. Basic user knowledge of computers and office applications.
3. Intermediate knowledge of HVAC systems.
4. Basic knowledge of DDC systems.
5. Basic knowledge of DDC system and products installed.

G. Attendee Training Manuals:

1. Provide each attendee with a color hard copy of all training materials and visual presentations.
2. Hard-copy materials shall be organized in a three-ring binder with table of contents and individual divider tabs marked for each logical grouping of subject

matter. Organize material to provide space for attendees to take handwritten notes within training manuals.

3. In addition to hard-copy materials included in training manual, provide each binder with a sleeve or pocket that includes a DVD or flash drive with PDF copy of all hard-copy materials.

H. Instructor Requirements:

1. One or multiple qualified instructors, as required, to provide training.
2. Instructors shall have not less than five years of providing instructional training on not less than five past projects with similar DDC system scope and complexity to DDC system installed.

I. Organization of Training Sessions:

1. Organize training sessions into logical groupings of technical content and to reflect different levels of operators having access to system. Plan training sessions to accommodate the following three levels of operators:
 - a. Daily operators.
 - b. Advanced operators.
 - c. System managers and administrators.
2. Plan and organize training sessions to group training content to protect DDC system security. Some attendees may be restricted to some training sessions that cover restricted content for purposes of maintaining DDC system security.

J. Training Outline:

1. Submit training outline for Owner review at least 10 business day before scheduling training.
2. Outline shall include a detailed agenda for each training day that is broken down into each of four training sessions that day, training objectives for each training session and synopses for each lesson planned.

K. On-Site Training:

1. Owner will provide conditioned classroom or workspace with ample desks or tables, chairs, power and data connectivity for instructor and each attendee.
2. Instructor shall provide training materials, projector and other audiovisual equipment used in training.
3. Provide as much of training located on-site as deemed feasible and practical by Owner.
4. On-site training shall include regular walk-through tours, as required, to observe each unique product type installed with hands-on review of operation, calibration and service requirements.
5. Operator workstation provided with DDC system shall be used in training. If operator workstation is not indicated, provide a temporary workstation to convey training content.

L. Off-Site Training:

1. Provide conditioned training rooms and workspace with ample tables desks or tables, chairs, power and data connectivity for each attendee.
2. Provide capability to remotely access to Project DDC system for use in training.
3. Provide a workstation for use by each attendee.

M. Training Content for Daily Operators:

1. Basic operation of system.
2. Understanding DDC system architecture and configuration.
3. Understanding each unique product type installed including performance and service requirements for each.
4. Understanding operation of each system and equipment controlled by DDC system including sequences of operation, each unique control algorithm and each unique optimization routine.
5. Operating operator workstations, printers and other peripherals.
6. Logging on and off system.
7. Accessing graphics, reports and alarms.
8. Adjusting and changing set points and time schedules.
9. Recognizing DDC system malfunctions.
10. Understanding content of operation and maintenance manuals including control drawings.
11. Understanding physical location and placement of DDC controllers and I/O hardware.
12. Accessing data from DDC controllers.
13. Operating portable operator workstations.
14. Review of DDC testing results to establish basic understanding of DDC system operating performance and HVAC system limitations as of Substantial Completion.
15. Running each specified report and log.
16. Displaying and demonstrating each data entry to show Project-specific customizing capability. Demonstrating parameter changes.
17. Stepping through graphics penetration tree, displaying all graphics, demonstrating dynamic updating, and direct access to graphics.
18. Executing digital and analog commands in graphic mode.
19. Demonstrating control loop precision and stability via trend logs of I/O for not less than 10 percent of I/O installed.
20. Demonstrating DDC system performance through trend logs and command tracing.
21. Demonstrating scan, update, and alarm responsiveness.
22. Demonstrating spreadsheet and curve plot software, and its integration with database.
23. Demonstrating on-line user guide, and help function and mail facility.
24. Demonstrating multitasking by showing dynamic curve plot, and graphic construction operating simultaneously via split screen.
25. Demonstrating the following for HVAC systems and equipment controlled by DDC system:

- a. Operation of HVAC equipment in normal-off, -on and failed conditions while observing individual equipment, dampers and valves for correct position under each condition.
- b. For HVAC equipment with factory-installed software, show that integration into DDC system is able to communicate with DDC controllers or gateways, as applicable.
- c. Using graphed trends, show that sequence of operation is executed in correct manner, and HVAC systems operate properly through complete sequence of operation including seasonal change, occupied and unoccupied modes, warm-up and cool-down cycles and other modes of operation indicated.
- d. Hardware interlocks and safeties function properly and DDC system performs correct sequence of operation after electrical power interruption and resumption after power is restored.
- e. Reporting of alarm conditions for each alarm, and confirm that alarms are received at assigned locations, including operator workstations.
- f. Each control loop responds to set point adjustment and stabilizes within time period indicated.
- g. Sharing of previously graphed trends of all control loops to demonstrate that each control loop is stable and set points are being maintained.

N. Training Content for Advanced Operators:

1. Making and changing workstation graphics.
2. Creating, deleting and modifying alarms including annunciation and routing.
3. Creating, deleting and modifying point trend logs including graphing and printing on an ad-hoc basis and operator-defined time intervals.
4. Creating, deleting and modifying reports.
5. Creating, deleting and modifying points.
6. Creating, deleting and modifying programming including ability to edit control programs off-line.
7. Creating, deleting and modifying system graphics and other types of displays.
8. Adding DDC controllers and other network communication devices such as gateways and routers.
9. Adding operator workstations.
10. Performing DDC system checkout and diagnostic procedures.
11. Performing DDC controllers operation and maintenance procedures.
12. Performing operator workstation operation and maintenance procedures.
13. Configuring DDC system hardware including controllers, workstations, communication devices and I/O points.
14. Maintaining, calibrating, troubleshooting, diagnosing and repairing hardware.
15. Adjusting, calibrating and replacing DDC system components.
16. <Insert requirement>.

O. Training Content for System Managers and Administrators:

1. DDC system software maintenance and backups.
2. Uploading, downloading and off-line archiving of all DDC system software and databases.
3. Interface with Project-specific, third-party operator software.

4. Understanding password and security procedures.
5. Adding new operators and making modifications to existing operators.
6. Operator password assignments and modification.
7. Operator authority assignment and modification.
8. Workstation data segregation and modification.

P. Video of Training Sessions:

1. Provide a digital video and audio recording of each training session. Create a separate recording file for each session.
2. Stamp each recording file with training session number, session name and date.
3. Provide Owner with two copies of digital files on DVDs or flash drives for later reference and for use in future training.
4. Owner retains right to make additional copies for intended training purposes without having to pay royalties.

END OF SECTION

SECTION 15950

TESTING, ADJUSTING, AND BALANCING FOR HVAC

PART 1 - GENERAL

1.1 SUMMARY

A. Section Includes:

1. Balancing Air Systems:

- a. Variable-air-volume systems for AHU-1
- b. Constant Volume systems for AHU-2, MUA-1.
AC-1/2 MTA-IT Room, Fan Coil Units, CUH'S,
- c. Ventilation Systems
- d. Cabinet and Unit Heaters

2. Balancing Hydronic Piping Systems:

- a. Variable-flow hydronic systems.

1.2 DEFINITIONS

- A. AABC: Associated Air Balance Council.
- B. NEBB: National Environmental Balancing Bureau.
- C. TAB: Testing, adjusting, and balancing.
- D. TABB: Testing, Adjusting, and Balancing Bureau.
- E. TAB Specialist: An independent entity meeting qualifications to perform TAB work.
- F. TDH: Total dynamic head.
- G. VAV: Variable Air Volume

1.3 INFORMATIONAL SUBMITTALS

- A. Strategies and Procedures Plan: Within 30 days of Contractor's Notice to Proceed, submit TAB strategies and step-by-step procedures as specified in "Preparation" Article.
- B. Certified TAB reports.

1.4 Action Submittals:

- A. Provide Preliminary and Final TAB reports. Reports shall comply with ASHRAE /IESNA 90.1 System Balancing.

1.5 QUALITY ASSURANCE

- A. TAB Specialists Qualifications: Certified by AABC, NEBB or TABB.
 - 1. TAB Field Supervisor: Employee of the TAB specialist and certified by AABC, NEBB or TABB. Supervisor shall have a minimum of 5 years experience.
 - 2. TAB Technician: Employee of the TAB specialist and certified by AABC, NEBB or TABB as a TAB technician, and have a minimum of 3 years experience.
- B. Instrumentation Type, Quantity, Accuracy, and Calibration: Comply with requirements in ASHRAE 111, Section 4, "Instrumentation."
- C. ASHRAE Compliance: Applicable requirements in ASHRAE 62.1, Section 7.2.2 - "Air Balancing."
- D. ASHRAE/IESNA Compliance: Applicable requirements in ASHRAE/IESNA 90.1, Section 6.7.2.3 - "System Balancing."

PART 2 - PRODUCTS (Not Applicable)

PART 3 - EXECUTION

3.1 EXAMINATION

- A. Examine the Contract Documents to become familiar with Project requirements and to discover conditions in systems designs that may preclude proper TAB of systems and equipment.
- B. Examine installed systems for balancing devices, such as test ports, gage cocks, thermometer wells, flow-control devices, balancing valves and fittings, and manual volume dampers. Verify that locations of these balancing devices are applicable for intended purpose and are accessible.
- C. Examine the approved submittals for HVAC systems and equipment.
- D. Examine design data including HVAC system descriptions, statements of design assumptions for environmental conditions and systems output, and statements of philosophies and assumptions about HVAC system and equipment controls.

- E. Examine ceiling plenums and underfloor air plenums used for supply, return, or relief air to verify that they are properly separated from adjacent areas. Verify that penetrations in plenum walls are sealed and fire-stopped if required.
- F. Examine equipment performance data including fan and pump curves.
 - 1. Relate performance data to Project conditions and requirements, including system effects that can create undesired or unpredicted conditions that cause reduced capacities in all or part of a system.
 - 2. Calculate system-effect factors to reduce performance ratings of HVAC equipment when installed under conditions different from the conditions used to rate equipment performance. To calculate system effects for air systems, use tables and charts found in AMCA 201, "Fans and Systems," or in SMACNA's "HVAC Systems - Duct Design." Compare results with the design data and installed conditions.
- G. Examine system and equipment installations and verify that field quality-control testing, cleaning, and adjusting specified in individual Sections have been performed.
- H. Examine test reports specified in individual system and equipment Sections.
- I. Examine HVAC equipment and verify that bearings are greased, belts are aligned and tight, filters are clean, and equipment with functioning controls is ready for operation.
- J. Examine terminal units, VAV: such as variable-air-volume boxes, and verify that they are accessible and their controls are connected and functioning.
- K. Examine AC and Associated CU for MTA-IT Room: verify accessible and connected for all functions, operation and controls.
- L. Examine AHU'S, MUA. FCU'S: verify units are accessible and connected for all functions and maintenance.
- M. Examine Heat Pump Units for Toll Booths: verify units are accessible and connected for all functions and maintenance. Verify on/off operations.
- N. Examine Cabinet Unit Heaters, Unit Heaters, and Baseboard Heaters: Verify that they are accessible, and their utilities and controls are connected and functioning. Test on/off operation and controls.
- O. Examine Boilers, HW pumps, and Hydronic Specialty equipment: Verify that all equipment are accessible and connected for all functions, operation and controls.
- P. Examine Operable Louvers: Verify operation of intake air louvers, connected for all functions, accessibility, opening and closing of louvers as access doors from Boiler room and Mechanical room to the areaways. Verify removal and assembly of louver air plenum and ductwork behind louver for access to the areaway.
- Q. Examine strainers. Verify that startup screens have been replaced by permanent screens with indicated perforations.

- R. Examine Air Filters. Verify that startup filters have been replaced by permanent filters.
- S. Examine control valves for proper installation for their intended function of throttling, diverting, or mixing fluid flows.
- T. Examine heat-transfer coils for correct piping connections and for clean and straight fins.
- U. Examine system pumps to ensure absence of entrained air in the suction piping.
- V. Examine operating safety interlocks and controls on HVAC equipment.
- W. Report deficiencies discovered before and during performance of TAB procedures. Observe and record system reactions to changes in conditions. Record default set points if different from indicated values.

3.2 PREPARATION

- A. Prepare a TAB plan that includes strategies and step-by-step procedures for balancing the systems.
 - 1. TAB shall all of the HVAC equipment and associated systems as per the following:
 - a. AHU-1/2, MUA-1
 - b. CU-1 for AHU-1
 - c. AC-1/2, CU-2/3
 - d. Fan Coil Units, and CU-4
 - e. Heat Pumps, Split system HP/CU
 - f. VAV terminal Units with HW reheat coils, and temperature sensors
 - g. Air Devices
 - h. Air Dampers
 - i. Unit Heaters
 - j. Baseboard heaters
 - k. Cabinet Unit Heaters
 - l. Boilers, Burners, ventFlue system
 - m. Hot Water Pumps and all specialties
 - n. HW control valves and control sensors
 - o. Operable Louvers
 - p. Supply and Exhaust Fans
- B. Perform system-readiness checks of HVAC systems and equipment to verify system readiness for TAB work. Include, at a minimum, the following:
 - 1. Airside:
 - a. Duct systems are complete with terminals installed.
 - b. Operable Louvers are functional
 - c. Volume, smoke, and fire dampers are open and functional.
 - d. Clean filters are installed.

- e. Fans are operating, free of vibration, and rotating in correct direction.
 - f. Variable-frequency controllers' startup is complete and safeties are verified.
 - g. Automatic temperature-control systems are operational.
 - h. Ceilings are installed.
 - i. Windows and doors are installed.
 - j. Suitable access to balancing devices and equipment is provided.
2. Hydronics:
- a. Verify leakage and pressure tests on water distribution systems have been satisfactorily completed.
 - b. Piping is complete with terminals installed.
 - c. Water treatment is complete.
 - d. Systems are flushed, filled, and air purged.
 - e. Strainers are pulled and cleaned.
 - f. Control valves are functioning per the sequence of operation.
 - g. Shutoff and balance valves have been verified to be 100 percent open.
 - h. Pumps are started and proper rotation is verified.
 - i. Pump gage connections are installed directly at pump inlet and outlet flanges or in discharge and suction pipe prior to valves or strainers.
 - j. Variable-frequency controllers' startup is complete and safeties are verified.
 - k. Suitable access to balancing devices and equipment is provided.

3.3 GENERAL PROCEDURES FOR TESTING AND BALANCING

- A. Perform testing and balancing procedures on each system according to the procedures contained in either acceptable AABC's "National Standards for Total System Balance" ASHRAE 111 NEBB's "Procedural Standards for Testing, Adjusting, and Balancing of Environmental Systems" SMACNA's "HVAC Systems - Testing, Adjusting, and Balancing" and in this Section.
- B. Cut insulation, ducts, pipes, and equipment cabinets for installation of test probes to the minimum extent necessary for TAB procedures.
 - 1. After testing and balancing, patch probe holes in ducts with same material and thickness as used to construct ducts.
 - 2. After testing and balancing, install test ports and duct access doors that comply with requirements in Section 15800 "Ductwork and Accessories".
 - 3. Provide and join new insulation that matches removed materials. Restore insulation, coverings, vapor barrier, and finish according to Section 15250 "Insulation".
- C. Mark equipment and balancing devices, including damper-control positions, valve position indicators, fan-speed-control levers, and similar controls and devices, with paint or other suitable, permanent identification material to show final settings.
- D. Take and report testing and balancing measurements in inch-pound (IP).

3.4 GENERAL PROCEDURES FOR BALANCING AIR SYSTEMS

- A. Prepare test reports for both fans and outlets. Obtain manufacturer's outlet factors and recommended testing procedures. Cross-check the summation of required outlet volumes with required fan volumes.
- B. Prepare schematic diagrams of systems' "as-built" duct layouts.
- C. For variable-air-volume systems, develop a plan to simulate diversity.
- D. Determine the best locations in main and branch ducts for accurate duct-airflow measurements.
- E. Check airflow patterns from the outdoor-air louvers and dampers and the return- and exhaust-air dampers through the supply-fan discharge and mixing dampers.
- F. Locate start-stop and disconnect switches, electrical interlocks, and motor starters.
- G. Verify that motor starters are equipped with properly sized thermal protection.
- H. Check dampers for proper position to achieve desired airflow path.
- I. Check for airflow blockages.
- J. Check condensate drains for proper connections and functioning.
- K. Check for proper sealing of air-handling-unit components.
- L. Verify that air duct systems are sealed, witness air leakage tests, as specified in Section 15800 "Ductwork and Accessories".
- M. Adjust air inlets and outlets for each space to indicated airflows.
 - 1. Set airflow patterns of adjustable outlets for proper distribution without drafts.
 - 2. Measure inlets and outlets airflow.
 - 3. Adjust each inlet and outlet for specified airflow.
 - 4. Re-measure each inlet and outlet after they have been adjusted.

3.5 PROCEDURES FOR VARIABLE-AIR-VOLUME SYSTEM-AHU-1, AND CONSTANT VOLUME SYSTEMs-AHU-2, MUA-1, FCU'S, HP'S, and AC'S:

- A. Adjust the variable-air-volume systems AHU-1) as follows:
 - 1. Verify that the system static pressure sensor is located two-thirds of the distance down the duct from the fan discharge. The pressure controller will be interconnected to the VFD for AHU-1.
 - 2. Verify that the system is under static pressure control.
 - 3. Select the terminal unit that is most critical to the supply-fan airflow. Measure inlet static pressure, and adjust system static pressure control set point so the entering static pressure for the critical terminal unit is not less than the sum of

the terminal-unit manufacturer's recommended minimum inlet static pressure plus the static pressure needed to overcome terminal-unit discharge system losses.

4. Calibrate and balance each terminal unit for maximum and minimum design airflow as follows:
 - a. Adjust controls so that terminal is calling for maximum airflow. Some controllers require starting with minimum airflow. Verify calibration procedure for specific project.
 - b. Measure airflow and adjust calibration factor as required for design maximum airflow. Record calibration factor.
 - c. When maximum airflow is correct, balance the air outlets downstream from terminal units.
 - d. Adjust controls so that terminal is calling for minimum airflow.
 - e. Measure airflow and adjust calibration factor as required for design minimum airflow. Record calibration factor. If no minimum calibration is available, note any deviation from design airflow.
 - f. On constant volume terminals, in critical areas where room pressure is to be maintained, verify that the airflow remains constant over the full range of full cooling to full heating. Note any deviation from design airflow or room pressure.
5. After terminals have been calibrated and balanced, test and adjust system for total airflow. Adjust fans to deliver total design airflows within the maximum allowable fan speed listed by fan manufacturer.
 - a. Set outside-air, return-air, and relief-air dampers for proper position that simulates minimum outdoor-air conditions.
 - b. Set terminals for maximum airflow. If system design includes diversity, adjust terminals for maximum and minimum airflow so that connected total matches fan selection and simulates actual load in the building.
 - c. Where duct conditions allow, measure airflow by Pitot-tube traverse. If necessary, perform multiple Pitot-tube traverses to obtain total airflow.
 - d. Where duct conditions are not suitable for Pitot-tube traverse measurements, a coil traverse may be acceptable.
 - e. If a reliable Pitot-tube traverse or coil traverse is not possible, measure airflow at terminals and calculate the total airflow.
6. Measure fan static pressures as follows:
 - a. Measure static pressure directly at the fan outlet or through the flexible connection.
 - b. Measure static pressure directly at the fan inlet or through the flexible connection.
 - c. Measure static pressure across each component that makes up the air-handling system.
 - d. Report any artificial loading of filters at the time static pressures are measured.

7. Set final return and outside airflow to the fan while operating at maximum return airflow and minimum outdoor airflow.
 - a. Balance the return-air ducts and inlets the same as described for constant-volume air systems.
 - b. Verify that terminal units are meeting design airflow under system maximum flow.
 - c. Verify and set Outside air, OA flows for meeting minimum OA per IMC, and set Air Flow Monitoring station, AFMS.

8. Re-measure the inlet static pressure at the most critical terminal unit and adjust the system static pressure set point to the most energy-efficient set point to maintain the optimum system static pressure. Record set point and give to controls contractor.
9. Verify final system conditions as follows:
 - a. Re-measure and confirm that minimum outdoor, return, and relief airflows are within design. Readjust to match design if necessary.
 - b. Re-measure and confirm that total airflow is within design.
 - c. Re-measure final fan operating data, rpms, volts, amps, and static profile.
 - d. Mark final settings.
 - e. Test system in economizer mode. Verify proper operation and adjust if necessary. Measure and record all operating data.

10. Constant Volume system, AHU-2 and MUA-1.
Verify final system conditions as follows:
 - a. AHU-2 is a two speed unit and includes a VFD for setting at 100 % flow (Summer mode), and 50% flow (Winter mode. Interlock Exhaust fans EF-6 and EF-7 for summer and winter modes.
 - b. Re-measure and confirm that minimum outdoor, and supply and return air flows are within design. Readjust to match design if necessary.
 - c. Re-measure and confirm that total airflow is within design.
 - d. Re-measure final fan operating data, rpms, volts, amps, and static profile.
 - e. Mark final settings.

11. Constant Volume systems-FCU'S, AC-1/2, Heat Pumps, HP-1-9:
Verify final system conditions as follows:
 - a. Re-measure and confirm that minimum outdoor, and supply and return air flows are within design. Readjust to match design if necessary.
 - b. Re-measure and confirm that total airflow is within design.
 - c. Re-measure final fan operating data, rpms, volts, amps, and static profile.
 - d. Mark final settings.

3.6 GENERAL PROCEDURES FOR HYDRONIC SYSTEMS

- A. Prepare test reports for pumps, coils, and heat exchangers. Obtain approved submittals and manufacturer-recommended testing procedures. Crosscheck the summation of required coil and heat exchanger flow rates with pump design flow rate.
- B. Prepare schematic diagrams of systems' "as-built" piping layouts.
- C. In addition to requirements in "Preparation" Article, prepare hydronic systems for testing and balancing as follows:
 - 1. Check liquid level in the existing expansion tank.
 - 2. Check highest vent for adequate pressure.
 - 3. Check flow-control valves for proper position.
 - 4. Locate start-stop and disconnect switches, electrical interlocks, and motor starters.
 - 5. Verify that motor starters and VFD'S are equipped with properly sized thermal protection.
 - 6. Check that air has been purged from the system.

3.7 PROCEDURES FOR CONSTANT FLOW, VARIABLE-FLOW, PRIMARY/SECONDARY HYDRONIC SYSTEMS:

- A. Adjust Primary Boiler pumps, BP-1/2 for constant flow through each boiler. Balance primary circuit flow for both boilers at rated conditions, first.
- B. Balance secondary circuits after the primary circuits are complete.
- C. Adjust Secondary HW pumps for each Zone, HWP-1/2, HWP-3/4, and HWP-5/6 at rated conditions
 - 1. Measure total water flow.
 - a. Position valves for full flow through coils.
 - b. If main flow meter is not installed, determine flow by pump TDH or exchanger pressure drop.
 - 2. Test and measure all HW pumps, and hot water Coil (freeze protection) pumps, associated TDH as follows:
 - a. Measure discharge pressure directly at the pump outlet flange or in discharge pipe prior to any valves.
 - b. Measure inlet pressure directly at the pump inlet flange or in suction pipe prior to any valves or strainers.
 - c. Convert pressure to head and correct for differences in gage heights.

- d. Verify pump impeller size by measuring the TDH with the discharge valve closed. Note the point on manufacturer's pump curve at zero flow, and verify that the pump has the intended impeller size.
 - e. With valves open, read pump TDH. Adjust pump discharge valve until design water flow is achieved.
3. Monitor motor performance during procedures and do not operate motor in an overloaded condition.
- D. Adjust flow-measuring devices installed in mains and branches to design water flows.
1. Measure flow in main and branch pipes.
 2. Adjust main and branch balance valves for design flow.
 3. Re-measure each main and branch after all have been adjusted.
- E. Adjust flow-measuring devices installed at terminals for each space to design water flows.
1. Measure flow at terminals.
 2. Adjust each terminal to design flow.
 3. Re-measure each terminal after it is adjusted.
 4. Position control valves to bypass the coil, and adjust the bypass valve to maintain design flow.
 5. Perform temperature tests after flows have been balanced.
- F. For systems with pressure-independent valves at terminals:
1. Measure differential pressure and verify that it is within manufacturer's specified range.
 2. Perform temperature tests after flows have been verified.
- G. For systems without pressure-independent valves or flow-measuring devices at terminals:
1. Measure and balance coils by either coil pressure drop or temperature method.
 2. If balanced by coil pressure drop, perform temperature tests after flows have been verified.
- H. Verify final system conditions as follows:
1. Re-measure and confirm that total water flow is within design.
 2. Re-measure final pumps' operating data, TDH, volts, amps, and static profile.
 3. Mark final settings.
- I. Verify that memory stops have been set.

3.8 TOLERANCES

- A. Set HVAC system's airflow rates and water flow rates within the following tolerances:
 - 1. Supply, Return, and Exhaust Fans and Equipment with Fans: Plus or minus 5 percent.
 - 2. Air Outlets and Inlets: Plus or minus 5 percent.
 - 3. Heating-Water Flow Rate: Plus or minus 5 percent
- B. Maintaining pressure relationships as designed shall have priority over the tolerances specified above.

3.9 FINAL REPORT

- A. General: Prepare a certified written report; tabulate and divide the report into separate sections for tested systems and balanced systems.
 - 1. Include a certification sheet at the front of the report's binder, signed and sealed by the certified testing and balancing engineer.
 - 2. Include a list of instruments used for procedures, along with proof of calibration.
 - 3. Certify validity and accuracy of field data.
- B. Final Report Contents: In addition to certified field-report data, include the following:
 - 1. Pump curves.
 - 2. Fan curves.
 - 3. Manufacturers' test data.
 - 4. Field test reports prepared by system and equipment installers.
 - 5. Other information relative to equipment performance; do not include Shop Drawings and Product Data.
- C. General Report Data: In addition to form titles and entries, include the following data:
 - 1. Title page.
 - 2. Name and address of the TAB specialist.
 - 3. Project name.
 - 4. Project location.
 - 5. Architect's name and address.
 - 6. Engineer's name and address.
 - 7. Contractor's name and address.
 - 8. Report date.
 - 9. Signature of TAB supervisor who certifies the report.
 - 10. Table of Contents with the total number of pages defined for each section of the report. Number each page in the report.

11. Summary of contents including the following:
 - a. Indicated versus final performance.
 - b. Notable characteristics of systems.
 - c. Description of system operation sequence if it varies from the Contract Documents.
 12. Nomenclature sheets for each item of equipment.
 13. Data for terminal units, including manufacturer's name, type, size, and fittings.
 14. Notes to explain why certain final data in the body of reports vary from indicated values.
 15. Test conditions for fans and pump performance forms including the following:
 - a. Settings for outdoor-, return-, and exhaust-air dampers.
 - b. Conditions of filters.
 - c. Cooling coil, wet- and dry-bulb conditions.
 - d. Face and bypass damper settings at coils.
 - e. Fan drive settings including settings and percentage of maximum pitch diameter.
 - f. Inlet vane settings for variable-air-volume systems.
 - g. Settings for supply-air, static-pressure controller.
 - h. Other system operating conditions that affect performance.
- D. System Diagrams: Include schematic layouts of air and hydronic distribution systems. Present each system with single-line diagram and include the following:
1. Quantities of outdoor, supply, return, and exhaust airflows.
 2. Water and steam flow rates.
 3. Duct, outlet, and inlet sizes.
 4. Pipe and valve sizes and locations.
 5. Terminal units.
 6. Balancing stations.
 7. Position of balancing devices.
- E. Air-Handling-Unit Test Reports: For air-handling units (AHU'S), MUA-1, and Fan Coil units with coils, include the following:
1. Unit Data:
 - a. Unit identification.
 - b. Location.
 - c. Make and type.
 - d. Model number and unit size.
 - e. Manufacturer's serial number.
 - f. Unit arrangement and class.
 - g. Discharge arrangement.
 - h. Sheave make, size in inches (mm), and bore.
 - i. Center-to-center dimensions of sheave and amount of adjustments in inches (mm).

- j. Number, make, and size of belts.
 - k. Number, type, and size of filters.
2. Motor Data:
 - a. Motor make, and frame type and size.
 - b. Horsepower and rpm.
 - c. Volts, phase, and hertz.
 - d. Full-load amperage and service factor.
 - e. Sheave make, size in inches (mm), and bore.
 - f. Center-to-center dimensions of sheave and amount of adjustments in inches (mm).
 - g. VFD's for AHU-1 and AHU-2.
 3. Test Data (Indicated and Actual Values):
 - a. Total airflow rate in cfm.
 - b. Total system static pressure in inches wg.
 - c. Fan rpm.
 - d. Discharge static pressure in inches wg.
 - e. Filter static-pressure differential in inches wg.
 - f. Preheat-coil static-pressure differential in inches wg.
 - g. Cooling-coil static-pressure differential in inches wg.
 - h. Heating-coil static-pressure differential in inches wg.
 - i. Outdoor airflow in cfm.
 - j. Return airflow in cfm.
 - k. Outdoor-air damper position.
 - l. Return-air damper position.
 - m. Vortex damper position.
- F. Apparatus-Coil Test Reports for AC units, and Heat Pumps, HP:
1. DX- Cooling Coil Data:
 - a. System identification.
 - b. Location.
 - c. Coil type.
 - d. Number of rows.
 - e. Fin spacing in fins per inch o.c.
 - f. Make and model number.
 - g. Face area in sq. ft.
 - h. Tube size in NPS.
 - i. Tube and fin materials.
 - j. Circuiting arrangement.
 2. Test Data (Indicated and Actual Values):
 - a. Airflow rate in cfm.
 - b. Average face velocity in fpm.
 - c. Air pressure drop in inches wg.

- d. Outdoor-air, wet- and dry-bulb temperatures in deg F.
 - e. Return-air, wet- and dry-bulb temperatures in deg F.
 - f. Entering-air, wet- and dry-bulb temperatures in deg F.
 - g. Leaving-air, wet- and dry-bulb temperatures in deg F.
 - h. Refrigerant expansion valve and refrigerant types.
 - i. Refrigerant suction pressure in psig.
 - j. Refrigerant suction temperature in deg F.
 - k. Inlet steam pressure in psig.
- G. Hot Water Coil Test Reports: For Fan Coil units (FCU'S), Cabinet Unit heaters (CUH), and unit coils installed in central-station air-handling units (AHU'S), Make up air unit (MUA-1), and VAV Reheat Coils include the following:
1. Unit Data:
 - a. System identification.
 - b. Location.
 - c. Coil identification.
 - d. Capacity in Btu/h.
 - e. Airflow rate in cfm.
 - f. Face area in sq. ft.
 - g. Minimum face velocity in fpm.
 2. Test Data (Indicated and Actual Values):
 - a. Heat output in Btu/h.
 - b. Airflow rate in cfm.
 - c. Air velocity in fpm.
 - d. Entering-air temperature in deg F.
 - e. Leaving-air temperature in deg F.
- H. Fan Test Reports: For supply, return, and exhaust fans, include the following:
1. Fan Data:
 - a. System identification.
 - b. Location.
 - c. Make and type.
 - d. Model number and size.
 - e. Manufacturer's serial number.
 - f. Arrangement and class.
 - g. Sheave make, size in inches, and bore.
 - h. Center-to-center dimensions of sheave and amount of adjustments in inches.
 2. Motor Data:
 - a. Motor make, and frame type and size.
 - b. Horsepower and rpm.
 - c. Volts, phase, and hertz.

- d. Full-load amperage and service factor.
 - e. Sheave make, size in inches, and bore.
 - f. Center-to-center dimensions of sheave, and amount of adjustments in inches.
 - g. Number, make, and size of belts.
3. Test Data (Indicated and Actual Values):
- a. Total airflow rate in cfm.
 - b. Total system static pressure in inches wg.
 - c. Fan rpm.
 - d. Discharge static pressure in inches wg.
 - e. Suction static pressure in inches wg.
- I. Round, Flat-Oval, and Rectangular Duct Traverse Reports: Include a diagram with a grid representing the duct cross-section and record the following:
1. Report Data:
- a. System and air-handling-unit number.
 - b. Location and zone.
 - c. Traverse air temperature in deg F.
 - d. Duct static pressure in inches wg.
 - e. Duct size in inches.
 - f. Duct area in sq. ft.
 - g. Indicated airflow rate in cfm.
 - h. Indicated velocity in fpm.
 - i. Actual airflow rate in cfm.
 - j. Actual average velocity in fpm.
 - k. Barometric pressure in psig.
- J. Air-Terminal-Device Reports:
1. Unit Data:
- a. System and air-handling unit identification.
 - b. Location and zone.
 - c. Apparatus used for test.
 - d. Area served.
 - e. Make.
 - f. Number from system diagram.
 - g. Type and model number.
 - h. Size.
 - i. Effective area in sq. ft.
2. Test Data (Indicated and Actual Values):
- a. Airflow rate in cfm.
 - b. Air velocity in fpm.
 - c. Preliminary airflow rate as needed in cfm.

- d. Preliminary velocity as needed in fpm.
 - e. Final airflow rate in cfm.
 - f. Final velocity in fpm.
 - g. Space temperature in deg F.
- K. Boilers, Gas-fired, refer to Section 15600, Hot Water Boilers for verifying boiler and burner connections, and including hot water, gas flue, and combustion air inlet for all functions, and operations.
- L. System Hot Water pumps (Primary and secondary HW pump systems), Hot Water Coil Pump Test Reports: Calculate impeller size by plotting the shutoff head on pump curves and include the following:
- 1. Unit Data:
 - a. Unit identification.
 - b. Location.
 - c. Service.
 - d. Make and size.
 - e. Model number and serial number.
 - f. Water flow rate in gpm.
 - g. Water pressure differential in feet of head or psig.
 - h. Required net positive suction head in feet of head or psig.
 - i. Pump rpm.
 - j. Impeller diameter in inches.
 - k. Motor make and frame size.
 - l. Motor horsepower and rpm.
 - m. Voltage at each connection.
 - n. Amperage for each phase.
 - o. Full-load amperage and service factor.
 - p. Seal type.
 - 2. Test Data (Indicated and Actual Values):
 - a. Static head in feet of head or psig.
 - b. Pump shutoff pressure in feet of head or psig.
 - c. Actual impeller size in inches.
 - d. Full-open flow rate in gpm.
 - e. Full-open pressure in feet of head or psig.
 - f. Final discharge pressure in feet of head or psig.
 - g. Final suction pressure in feet of head or psig.
 - h. Final total pressure in feet of head or psig.
 - i. Final water flow rate in gpm.
 - j. Voltage at each connection.
 - k. Amperage for each phase.
- M. Instrument Calibration Reports:
- 1. Report Data:

- a. Instrument type and make.
- b. Serial number.
- c. Application.
- d. Dates of use.
- e. Dates of calibration.

N. VENTILATION SYSTEMS

1. Balance all Exhaust fans per meeting rated air flows, and provide the following:
 - a. Unit identification.
 - b. Location.
 - c. Make and type.
 - d. Model number and unit size.
 - e. Manufacturer's serial number.
 - f. Unit arrangement and class.
 - g. Discharge arrangement.
 - h. Sheave make, size in inches (mm), and bore.
 - i. Center-to-center dimensions of sheave and amount of adjustments in inches (mm).
 - j. Number, make, and size of belts.
2. Motor Data:
 - a. Motor make, and frame type and size.
 - b. Horsepower and rpm.
 - c. Volts, phase, and hertz.
 - d. Full-load amperage and service factor.
 - e. Sheave make, size in inches (mm), and bore.
 - f. Center-to-center dimensions of sheave and amount of adjustments in inches (mm).

3.10 VERIFICATION OF TAB REPORT

- A. The TAB specialist's test and balance engineer shall conduct the inspection in the presence of commissioning authority.
- B. Commissioning authority shall randomly select measurements, documented in the final report, to be rechecked. Rechecking shall be limited to either 10 percent of the total measurements recorded or the extent of measurements that can be accomplished in a normal 8-hour business day.
- C. If rechecks yield measurements that differ from the measurements documented in the final report by more than the tolerances allowed, the measurements shall be noted as "FAILED."
- D. If the number of "FAILED" measurements is greater than 10 percent of the total measurements checked during the final inspection, the testing and balancing shall be considered incomplete and shall be rejected.

- E. If TAB work fails, proceed as follows:
 - 1. TAB specialists shall recheck all measurements and make adjustments. Revise the final report and balancing device settings to include all changes; resubmit the final report and request a second final inspection.
 - 2. If the second final inspection also fails, Owner may contract the services of another TAB specialist to complete TAB work according to the Contract Documents and deduct the cost of the services from the original TAB specialist's final payment.
 - 3. If the second verification also fails, Owner or design professional may contact AABC Headquarters regarding the AABC National Performance Guaranty.
- F. Prepare test and inspection reports.

3.11 ADDITIONAL TESTS

- A. Within 90 days of completing TAB, perform additional TAB to verify that balanced conditions are being maintained throughout and to correct unusual conditions.
- B. Seasonal Periods: If initial TAB procedures were not performed during near-peak summer and winter conditions, perform additional TAB during near-peak summer and winter conditions.

END OF SECTION

SECTION 15955COMMISSIONING OF HVAC

PART 1 - GENERAL

1.1 SUMMARY

- A. Section includes commissioning process requirements for the following HVAC&R systems, assemblies, and equipment:
 - 1. Heat generation systems, including existing hot-water boilers, and auxiliary equipment. Verification of operations and controls of existing systems.
 - 2. Cooling generation systems, including new direct-expansion systems.
 - 3. Distribution systems, including air distribution (heating and cooling) systems, hot-water and chilled water distribution systems, exhaust systems, and air-handling units.
 - 4. Terminal and packaged units, including VAV Boxes.
 - 5. Vibration and sound systems, including sound attenuation vibration isolation devices seismic restraints.
 - 6. DDC Controls and instrumentation, including new and existing BMS. Interlock new BMS with existing building's BMS.
 - 7. Systems testing and balancing verification, including heating-water piping systems, hot-water circulating systems, supply-air systems return-air systems, exhaust-air systems, and plumbing (domestic cold and hot water) systems.

1.2 DEFINITIONS

- A. BMS: Building Management System.
- B. DDC: Direct digital controls.
- C. HVAC&R: Heating, Ventilating, Air Conditioning, and Refrigeration.
- D. "Systems," "Subsystems," "Equipment," and "Components": Where these terms are used together or separately, they shall mean "as-built" systems, subsystems, equipment, and components.
- E. TAB: Testing, adjusting, and balancing.

1.3 INFORMATIONAL SUBMITTALS

- A. Qualification Data: For BMS and HVAC&R Testing Technician.
- B. Construction Checklists: For the following:
 - 1. Vibration and seismic controls for HVAC&R piping and equipment.
 - 2. Instrumentation and control for HVAC&R.

3. Heating-water piping and accessories.
4. Boilers, and primary water pumps
5. Secondary Hot Water pumps.
6. Hot water piping systems, and accessories.
7. Refrigerant piping.
8. Metal ducts and accessories.
9. Fans, supply and exhaust.
10. VAV terminal units. And CAV
11. Air-handling units, AHU-S.
12. Combustion Air Unit, MUA-1.
13. Heat Pumps, Split units for the Toll Booths.
14. Computer-room ductless air conditioners, and condensing units.
15. Condensing Units.
16. Fan Coil Units.
17. Cabinet Unit Heaters.
18. Unit heaters, propeller type.
19. Baseboard heating units.
20. Radon Mitigation system.

1.4 QUALITY ASSURANCE

- A. BMS Testing Technician Qualifications: Technicians to perform BMS construction checklist verification tests, construction checklist verification test demonstrations, commissioning tests, and commissioning test demonstrations shall have the following minimum qualifications:
 1. Journey-level or equivalent skill level with knowledge of BAS, HVAC&R, electrical concepts, and building operations.
 2. Minimum three years' experience installing, servicing, and operating systems manufactured by approved manufacturer.
 3. International Society of Automation (ISA) Certified Control Systems Technician (CCST) Level I.

- B. HVAC&R Testing Technician Qualifications: Technicians to perform HVAC&R construction checklist verification tests, construction checklist verification test demonstrations, commissioning tests, and commissioning test demonstrations shall have the following minimum qualifications:
 1. Journey-level or equivalent skill level. Vocational School four-year program graduate or an Associates degree in mechanical systems, air conditioning, or similar field. Degree may be offset by three years' experience in servicing mechanical systems in the HVAC industry. Generally, required knowledge includes HVAC&R systems, electrical concepts, building operations, and application and use of tools and instrumentation to measure performance of HVAC&R equipment, assemblies, and systems.
 2. Minimum three years' experience installing, servicing, and operating systems manufactured by approved manufacturer.
 3. One of the following:

- a. National Environmental Balancing Bureau (NEBB) Certified Testing, Adjusting, and Balancing Technician.
 - b. Associated Air Balance Council (AABC) Certified Test and Balance Technician.
 - c. Owner retains the right to waive NEBB or AABC Certification.
- C. Testing Equipment and Instrumentation Quality and Calibration: For test equipment and instrumentation required to perform HVAC&R commissioning work, perform the following:
1. Submit test equipment and instrumentation list. For each equipment or instrument, identify the following:
 - a. Equipment/instrument identification number.
 - b. Planned commissioning application or use.
 - c. Manufacturer, make, model, and serial number.
 - d. Calibration history, including certificates from agencies that calibrate the equipment and instrumentation.
 2. Test equipment and instrumentation shall meet the following criteria:
 - a. Capable of testing and measuring performance within the specified acceptance criteria.
 - b. Be calibrated at the manufacturer's recommended intervals with current calibration tags permanently affixed to the instrument being used.
 - c. Be maintained in good repair and operating condition throughout the duration of use on this Project.
 - d. Be recalibrated/repared if dropped or damaged in any way since last calibrated.
- D. Proprietary Test Instrumentation and Tools:
1. Equipment Manufacturer's Proprietary Instrumentation and Tools: For installed equipment included in the commissioning process, test instrumentation and tools manufactured or prescribed by equipment manufacturer to service, calibrate, adjust, repair, or otherwise work on its equipment or required as a condition of equipment warranty, perform the following:
 - a. Submit proprietary instrumentation and tools list. For each instrument or tool, identify the following:
 - 1) Instrument or tool identification number.
 - 2) Equipment schedule designation of equipment for which the instrument or tool is required.
 - 3) Manufacturer, make, model, and serial number.
 - 4) Calibration history, including certificates from agencies that calibrate the instrument or tool, where appropriate.
 - b. Include a separate list of proprietary test instrumentation and tools in the operation and maintenance manuals.

- c. HVAC&R proprietary test instrumentation and tools become the property of Owner at the time of Substantial Completion.

PART 2 - PRODUCTS (Not Used)

PART 3 - EXECUTION

3.1 GENERAL TESTING REQUIREMENTS

- A. Certify that HVAC&R systems, subsystems, and equipment have been installed, calibrated, and started and are operating according to the Contract Documents and approved Shop Drawings and submittals.
- B. Certify that HVAC&R instrumentation and control systems have been completed and calibrated, that they are operating according to the Contract Documents and approved Shop Drawings and submittals, and that pretest set points have been recorded.
- C. Certify that TAB procedures have been completed and that TAB reports have been submitted, discrepancies corrected, and corrective work approved.
- D. Set systems, subsystems, and equipment into operating mode to be tested according to approved test procedures (e.g., normal shutdown, normal auto position, normal manual position, unoccupied cycle, emergency power, and alarm conditions).
- E. Construction Checklists: Prepare and submit detailed construction checklists for HVAC&R systems, subsystems, equipment, and components.
 1. Contributors to the development of construction checklists shall include, but are not limited to, the following:
 - a. HVAC&R systems and equipment installers.
 - b. TAB technicians.
 - c. HVAC&R instrumentation and controls contractors for designing and building new DDC system including new BMS and integrating with existing BMS system.
- F. Perform tests using design conditions, whenever possible.
 1. Simulated conditions may, with approval of Construction Manager, be imposed using an artificial load when it is impractical to test under design conditions. Before simulating conditions, calibrate testing instruments. Provide equipment to simulate loads. Set simulated conditions as directed by Commissioning Coordinator and document simulated conditions and methods of simulation. After tests, return configurations and settings to normal operating conditions.
 2. Commissioning test procedures may direct that set points be altered when simulating conditions is impractical.

3. Commissioning test procedures may direct that sensor values be altered with a signal generator when design or simulating conditions and altering set points are impractical.
- G. If tests cannot be completed because of a deficiency outside the scope of the HVAC&R system, document the deficiency and report it to Owner. After deficiencies are resolved, reschedule tests.
- H. If seasonal testing is specified, complete appropriate initial performance tests and documentation and schedule seasonal tests.
- I. Coordinate schedule with, and perform the following activities at the direction of, Commissioning Coordinator.
- J. Comply with construction checklist requirements, including material verification, installation checks, start-up, and performance tests requirements specified in Sections specifying HVAC systems and equipment.
- K. Provide technicians, instrumentation, tools, and equipment to complete and document the following:
 1. Performance tests.
 2. Demonstration of a sample of performance tests.
 3. Commissioning tests.
 4. Commissioning test demonstrations.

3.2 TAB VERIFICATION TESTS

- A. TAB Verification:
 1. Conditions of the Test:
 - a. Commissioning Test Demonstration Sampling Rate: As specified in "Inspections" Article in Section 15950 "Testing, Adjusting, and Balancing for HVAC".
 - b. Systems operating in full heating mode with minimum outside-air volume.
 - c. Systems operating in full cooling mode with minimum and maximum outside-air volumes.
 - d. For measurements at air-handling units with economizer controls; systems operating in economizer mode with 100 percent outside air.
 2. Acceptance Criteria:
 - a. Under all conditions, rechecked measurements comply with "Inspections" Article in Section 15950 "Testing, Adjusting, and Balancing for HVAC".
 - b. Additionally, no rechecked measurement shall differ from measurements documented in the final report by more than two times the tolerances allowed.

- c. Under all conditions, where the Contract Documents indicate a differential in airflow between supply and exhaust and/or return in a space, the differential relationship shall be maintained.

3.3 HEATING CONTROL SYSTEM COMMISSIONING TESTS

A. Heating-Water Supply Temperature Control and Verification:

1. Prerequisites: verification of the following new HW system:
 - a. Startup of boilers.
 - b. Startup of heating-water pump(s).
 - c. TAB of heating-water flow and pressure.
 - d. Input Device: Heating-water supply temperature; thermistor temperature sensor designations.
 - e. Output Device: Control valve Insert device designation.
 - f. Display the following at the operator's workstation:
 - 1) Heating-water supply temperature.
 - 2) Heating-water supply temperature set point.
 - 3) Control-valve position.
2. Conditions of the Test:
 - a. Minimum heating-water flow.
 - b. Midrange Heating-Water Flow: 50 to 60 percent of maximum.
 - c. Maximum heating-water flow.
3. Acceptance Criteria: Under all conditions, heating-water supply temperature is within plus or minus 2.0 deg F of set point.

B. Control of HW Freeze protection Circulating Pump(s) at:

1. Prerequisites: Installation verification of the following:
 - a. Startup of new HW coil circulating pump(s).
 - b. Input Device: Outdoor-air temperature; electric, outdoor-air-reset controller or outdoor-air sensor.
 - c. Output Device: Heating-water pump; DDC system command to starter relay.
 - d. Display the following at the operator's workstation:
 - 1) Outdoor-air temperature.
 - 2) Operating status of primary circulating pump(s).
2. Conditions of the Test:
 - a. Pumps operate when freezestat is activated, or when outdoor air temperature falls below 38 deg F (adj.) to protect the HW in coil from freezing.

3. Acceptance Criteria:
 - a. Verify settings for conditions for freeze protection.

3.4 TERMINAL UNIT EQUIPMENT COMMISSIONING TESTS

A. Terminal Air Units with Hydronic Heating Coil including VAV, CAV, MUA-1, and FCU'Ss:

1. Prerequisites: Installation verification of the following:
 - a. Occupancy Input Device: Occupancy sensor.
 - b. Occupancy Output Device: DDC system binary output.
 - c. Room Temperature Input Device: Room Electronic temperature sensor.
 - d. Room Temperature Output Device: Electronic damper actuators and control-valve operators.
 - e. Display the following at the operator's workstation:
 - 1) Room/area served.
 - 2) Room occupied/unoccupied.
 - 3) Room temperature indication.
 - 4) Room temperature set point.
 - 5) Room temperature set point, occupied.
 - 6) Room temperature set point, unoccupied.
 - 7) Air-damper position as percentage open.
2. Conditions of the Test:
 - a. Commissioning Test Demonstration Sampling Rate: 50 percent of each model/size unit.
 - b. Temperature Control - Occupied: Start with the room unoccupied. Occupy the room and observe the change to occupied status. Observe temperature control until room temperature is stable at occupied set point plus or minus 1.0 deg F.
 - c. Temperature Control - Unoccupied: Start with the room occupied. Vacate the room and observe the change to unoccupied status. Observe temperature control until room temperature is stable at unoccupied set point plus or minus 2.0 deg F.
3. Acceptance Criteria:
 - a. Temperature Control - Unoccupied:
 - 1) Control system status changes from "occupied" to "unoccupied" after the specified time.
 - 2) Room temperature is stable at occupied set point plus or minus 1.0 deg F within 10 minutes of occupancy. Room temperature does not overshoot or undershoot set point by more than 2.0 deg F during transition.

- b. Temperature Control - Occupied:
 - 1) Control system status changes from "unoccupied" to "occupied" after five minutes of continuous occupancy. (adj.)
 - 2) Room temperature is stable at unoccupied set point plus or minus 2.0 deg F within 30 minutes of occupancy.

3.5 AIR-HANDLING SYSTEM COMMISSIONING TESTS

A. Supply Fan(s) Variable-Volume Control-AHU-1, AHU-2 (2 speed), and MAU-1 (CAV):

1. Prerequisites: Installation verification of the following:

- a. Volume Control Input Device: Static-pressure transmitter or Differential-pressure switch sensing supply-duct static pressure referenced to conditioned-space static pressure.
- b. Volume Control Output Device: DDC system analog output to modulating damper actuator. Set inlet guide vanes to minimum closed position when fan is stopped.
- c. Volume Control Input Device: Static-pressure transmitter or Differential-pressure switch] sensing supply-duct static pressure referenced to conditioned-space static pressure.
- d. Volume Control Output Device: DDC system analog output to motor speed controller. Set variable-speed drive to minimum speed when fan is stopped.
- e. High-Pressure Input Device: Static-pressure transmitter sensing supply-duct static pressure referenced to static pressure outside the duct.
- f. High-Pressure Output Device: DDC system binary output to alarm panel.
- g. Display the following at the operator's workstation:
 - 1) Supply-fan-discharge static-pressure indication.
 - 2) Supply-fan-discharge static-pressure set point.
 - 3) Supply-fan airflow rate.
 - 4) Supply-fan speed.
 - 5) Exhaust fan, on/off for AHU-1, only

2. Conditions of the Test:

- a. Minimum air flow (SF).
- b. Midrange Air Flow (SA): 50 to 60 percent of maximum.
- c. Maximum (SF) air flow.
- d. Excess air discharge static pressure (SF).
- e. Exhaust fan for AHU-1, VAV operation

3. Acceptance Criteria:

- a. At all supply-air flow rates, and during changes in supply-air flow, discharge air static pressure is at set point plus or minus 2 percent.

- b. Fan stops and an alarm is initiated at the operator's workstation when supply-air discharge static pressure is at the excess static pressure plus or minus 2 percent.
- B. Hydronic Control valves for AHU-1, AHU-2, MUA-1:
 - 1. Perform installation verifications and acceptance tests for the following:
 - a. HW heating coil temperature control valve and interlock with AHU'S, and AHU-1 DDC controllers.
 - b. Provide sequencing for maintaining discharge air temperature setpoint.
- C. DX Cooling for AHU-1, and Heat Pumps, HP-1 thru 9:
 - 1. Perform installation verifications and acceptance tests for the following:
 - a. Cooling coil temperature control with sequencing condensing unit and interlock with DDC controller.
 - b. Provide sequencing for maintaining discharge air temperature setpoint.
- D. DX Cooling for AC-1/2:
 - 1. Perform installation verifications and acceptance tests for the following:
 - a. Cooling coil temperature control for the MTA/IT room with sequencing condensing unit and interlock with DDC.
 - b. Provide sequencing for maintaining space temperature setpoint.

3.6 HYDRONIC HEATING SYSTEM

- A. Hot Water System
 - 1. Perform installation verifications and acceptance tests for the following:
 - a. HW heating coil temperature control valve and interlock with DDC controllers, and provide sequencing for maintaining space temperature.
 - b. Hydronic Control valves for MUA-1, Unit Heaters(UH), Cabinet Unit Heaters(CUH), Baseboard heaters(BBH), Fan Coil Units (FCU):
- B. Boiler System Controls
 - 1. Perform installation verification and acceptance test for the following:
 - a. Boiler Burner tests regarding turndown ratio 5:1 modulation,
 - b. Boiler operation,
 - c. Primary Boiler pumps,
 - d. Stack flue tests, temperature, draft
 - e. Secondary water pumps for all three (3) zones (Administration Building, perimeter Administration Building and tunnel distribution).
 - f. HW System tests, HW supply control, HW pressure for pump controls.

END OF SECTION

SECTION 15990SEQUENCE OF OPERATIONS FOR HVAC DDC

PART 1 - GENERAL

1.1 SUMMARY

- A. Section includes control sequences for DDC for HVAC systems, subsystems, and equipment.
- B. Related Requirements:
 - 1. Section 15920 "DDC System for HVAC" for control equipment.

1.2 HEATING CONTROL SEQUENCES

- A. Control all Hot Water (HW) Circulating Pump(s):
 - 1. Energize primary and secondary HW pump(s) at outdoor-air temperatures below 65 deg F (18 deg C).
- B. Boiler Primary Circulating Pump(s): Energize pump(s), BP-1, and BP-2, when respective boiler (B-1, B-2) is called to start, and maintain operation. BP-1 and 2 are constant volume flow.
- C. All circulating HW Pump(s) Failure Alarm: Signal alarm condition, if there is no pressure differential between supply and return piping. Controls contractor shall provide differential pressure switch for control and locate as required for proper operation.
- D. Secondary HW Pumps(s), HWP-1/2, 3/4, 5/6: Operate pump(s) on lead-lag controls, alternating each on run hours (weekly basis, or hours and adjustable). These pumps will have VFD'S for maintaining pressure in HW piping system for each zone.
- E. Control Secondary HW Pump(s) Speed: Control pump speed via motor VFD and shall maintain pressure with differential switch (DPS). Locate DPS in system piping based on system for proper operation.
 - 1. Zone 1 for the Administration building AHU-1 and include 2-way control valves, and 3-way diverting valves for AHU-2, and MUA-1 with freeze pumps.
 - 2. Zone 2 for the tunnel include unit heaters with 2-way control valves, and the Toll Booth CUH- do not include control valves. Each CUH has balancing valves for constant flow.
 - 3. Zone 3 includes 2-way control valves for VAV reheat coils, BBH'S, FCU'S, and UH/CUH.
- F. Heating-Water Supply Temperature Control:
 - 1. Control Boiler through the burner controls to maintain heating-water supply temperature.

2. Control both boilers (non-condensing type) utilizing lead/lag controls down to 40 deg F, OA temperature, then operate both boilers below 40 deg F, OA Temperature.
3. Reset heating-water supply temperature in straight-line relationship with outdoor-air temperature for the following conditions:
 - a. Highest temperature of HWS of 200 deg F heating water when outdoor-air temperature is 0.0 deg F.
 - b. HWS of 150 deg F lowest temperature heating water when outdoor-air temperature is 60 deg F.
 - c. Minimum of 140 deg F for HW return, or above the condensing temperature of the flue.

G. Indicate the following on the operator's workstation display terminal:

1. DDC system graphic.
2. DDC system status, on-off.
3. Outdoor-air temperature.
4. Boiler #1 Enable (ON).
5. Boiler #1 failure.
6. Boiler #1 Disable(OFF).
7. Boiler # 2 Enable (ON).
8. Boiler #2 failure.
9. Boiler #2 Disable (OFF).
10. Primary Boiler HW pump(s) BP-1/2 on-off status (enabled or disabled).
11. Primary Boiler HW pump(s) BP-1/2 on-off indication (operating or not operating).
12. Primary circulating pump(s) pressure differential.
13. Primary circulating pump(s) pressure differential set point.
14. Secondary HW circulating pump(s) on-off indication (operating or not operating).
15. Secondary HW pump(HWP1-6) HWP-alarm pressure differential.
16. Circulating pump(s) alarm pressure differential set point.
17. Alarm (circulating pump(s) failure).
18. Secondary HW pump(s) speed pressure differential.
19. Secondary HW pump(s) speed pressure differential set point.
20. Secondary HW pump(s) speed.
21. Heating-water supply temperature.
22. Heating-water return temperature.
23. Heating-water supply temperature set point.

1.3 AIR-HANDLING-UNIT CONTROL SEQUENCES

A. Air-Handling Unit Occupied Time Schedule, AHU-1 (VAV) serves the 1st floor Administration Building. AHU-2 (CAV) serves the Tunnels is similar to AHU-1, but does not have cooling coil and no condensing unit. MUA-1 serves the boiler room for combustion air and is similar to AHU-2 for on/off operation.

1. Control system shall include Winter/ Summer modes of operation via the BMS.

2. Enable startup, initiation, and control.
3. Enable control of heating coil(s) during morning warm-up period.
4. Return heating control valves to normal position when unit is on.
5. Do not enable cooling-coil control during morning warm-up period.

B. Start and Stop Supply Fan(s):

1. When AHU-1 is commanded "ON", then start and run supply fan continuously. AHU-2, and MUA-1 are similar for heating only.
2. When AHU-2, MUA-1 is commanded "ON", then start and run supply fan continuously.
3. AHU-2 will have 2-speed conditions for winter and summer using a VFD.
4. Fan is off when Commanded "OFF".
5. Signal alarm if fan fails to start as commanded.

C. Supply Fan(s) Variable-Volume Control (AHU-1, AHU-2)

1. AHU-1 Fan Speed Control:
 - a. Maintain constant supply-duct static-pressure set point of 1.50" WC (adj.).
 - b. Set-Point Reset (for Systems with DDC of Individual Zone Terminals): Reset static-pressure set point based on the zone requiring the most pressure; reset set point lower until one zone damper is nearly wide open.
 - c. Set variable-frequency drive for AHU-1 to minimum speed when fan is stopped.
2. Fan Airflow: Report supply-duct airflow via VFD.
3. Outside air (OA) flow via the Air Flow Monitoring Station (AFMS) to maintain minimum OA flow, as per indicated on the schedules.
4. High Pressure: When static pressure rises above excessive-static-pressure set point of 3.0" WC.
5. AHU-2 will use VFD to provide 2 speeds, high speed for summer, and low speed for winter. Interlock exhaust fans, EF-6 and 7 with AHU -2 fan operation. EF-7 shall run during the winter and AHU-2 is on low speed. EF-6 and 7 shall operate during summer and AHU-2 is on high speed. Controls to include Winter and Summer modes based on OA temperatures.
 - a. Stop fan.
 - b. Signal alarm.

D. Preheat Coil:

1. Freeze Protection: Allow air-handling unit to continue to run if the following:
 - a. OA damper is closed at start
 - b. Operate AHU-1 100 % RA
 - c. Then open OA damper if duct temperature is above 35 deg F (adj.)
2. Low-Temperature Operation, AHU-2 only: Energize coil circulating pump(s) at discharge-air temperatures is below 35 deg F (2 deg C)

3. Discharge-AHU-1, Air Temperature: Maintain air-temperature set point of 60 deg F utilizing 2-way HW temperature control valves, and discharge air temp sensor. The VAV boxes include HW terminal reheat coils that will maintain space temperature.
 4. Discharge air temperature, AHU-2, and MUA-1 maintain temp setpoint at 80 deg F (adj.).
- E. Mixed-Air Control:
1. Minimum Position:
 - a. Air Flow station for AHU-1 shall be used to maintain minimum OA flow.
 2. Retain "Heating Reset" Subparagraph below when the air-handling-unit is used to heat either during unoccupied hours (close dampers) or during the occupied hours (minimum position).
 3. Carbon Dioxide Reset: Reset minimum outdoor-air damper position to maintain carbon dioxide set point of 900 PPM. CO 2 detector is located in the Counting room
- F. Filters: Signal alarm on high-pressure differential conditions.
- G. Direct Expansion, DX Cooling Coil (AHU-1, only):
1. Discharge-Air Temperature:
 - a. Maintain supply-air-temperature set point of 55 deg F (13 deg C) by operating condensing unit, CU-1 via enabling and disabling compressors.
 - b. Supply-Air-Temperature Reset: Reset the supply-air temperature to outdoor temperature at least 25 percent of the difference between the design supply-air temperature and the design room air temperature.
- H. Coordination of Air-Handling Unit Sequences: Ensure that preheat, minimum OA (via AFMS), heating-coil, and cooling-coil controls have common inputs and do not overlap in function.
- I. Indicate the following on the operator's workstation display terminal:
1. DDC system graphic.
 2. DDC system on-off indication (operating or not operating).
 3. DDC system occupied/unoccupied mode.
 4. Outdoor-air-temperature indication.
 5. Supply-fan on-off indication (operating or not operating).
 6. Supply duct static-pressure indication.
 7. Supply duct static-pressure set point.
 8. Supply-fan airflow rate.
 9. Supply-fan speed.
 10. Space static-pressure indication.
 11. Space static-pressure set point.
 12. Preheat-coil air-temperature indication.
 13. Preheat-coil air-temperature set point.

14. Preheat-coil pump on-off indication (operating or not operating).
15. Preheat-coil control-valve position.
16. Mixed-air-temperature indication.
17. Filter air-pressure-drop indication.
18. Filter high-air-pressure drop set point.
19. Discharge-air-temperature indication.
20. Discharge-air-temperature set point.
21. Cooling-coil leaving-air-temperature indication (AHU-1).
22. Cooling-coil leaving-air-temperature set point.
23. Condensing unit enable (AHU-1)
24. Condensing unit disable.
25. Space temperature indication.
26. Space temperature set point.

1.4 TERMINAL UNIT OPERATING SEQUENCE

A. Cabinet Unit Heaters, CUH-4 through 12, Hydronic, Toll Booths:

1. Return Temperature: Cycle fan to maintain return air temperature at 70 deg F.
2. Space Temperature CUH-4 thru 12:
 - a. the hot water return flow will be balanced for rated flow, and does NOT include a temperature control with associated thermostat.
 - b. The occupants will adjust 3-speed fan for the CUH heating control
 - c. Space temperature sensor interconnected with CUH controller.
3. Low-Temperature Safety: Stop fan when return heating-water temperature falls below 35 deg F. Local temperature sensor in toll booth shall monitor space temperature.
4. CUH-1/2/3: Located at the Administration Building doors areas shall maintain return air temperature at 65 deg F with 2-way HW temperature control valve.
5. Space temperature sensor (2nd sensor) shall be monitored by the BMS for remote monitoring and alarms (low temp, high temp).

B. Unit Heaters, UH-3 thru UH-12 serve the Tunnel, Hydronic:

1. Space Temperature:
 - a. Modulate 2-way HW control valve to maintain space temperature at 65 deg F(Adj.)
2. Low-Temperature Safety: Stop fan when return heating-water temperature falls below 35 deg F (2 deg C).
3. Local temperature sensors located along tunnel wall, and within the tunnel shall monitor space temperature and signal alarm to the BMS.

- C. Unit Heaters, UH-1/2 Mechanical/Boiler Rooms: Space thermostat to provide heating to maintain 65 deg F space temperature. Unit heaters shall maintain space temperature with 2-way HW control valves
- D. Combustion-Air Unit Heater, MUA-1 in Boiler Room: Modulate HW Control valve to maintain discharge temperature at 90 deg F temperature. Refer to MUA-1 sequences of operation for providing combustion air to boilers when boilers are operational. Refer to item 1.5-A below for the sequences of operation.
- E. Two-Pipe, Single-Coil, Fan-Coil Units, FCU-2/3:
 - 1. Manual Start: Start and stop fan.
 - 2. Space Temperature: Modulate HW valve to maintain space temperature set points.
 - 3. On until commanded "OFF".
- F. Hydronic Fan-Coil Unit, FCU-1, plus DX cooling Coil:
 - 1. Occupied Time Schedule: Start and stop fan, and enable control.
 - 2. Space Temperature: Modulate HW control valves to maintain space temperature set points during heating. Cycle condensing unit compressors to maintain space temperature.
 - 3. On until commanded "OFF".
 - a. Cooling Temperature: 75 deg F (24 deg C)
 - b. Heating Temperature: 70 deg F (24 deg C).
 - c. Run continuously.
- G. Split System AC-1/2, CU-2/3, MTA IT Room:
 - 1. Start and run split system continuously to maintain room temperature setpoint.
 - 2. On until commanded "OFF"
 - 3. Manually started via the FM-200/FACP.
- H. Radiators and Convectors, Hydronic:
 - 1. Occupancy: Report occupancy and enable occupied temperature set point.
 - 2. Space Temperature: Local control of baseboard heaters per room via modulating the HW temperature valve to maintain 65 deg F (adj) space temperature set point.
 - 3. Each room will include temperature control valve to control heating of multiple baseboard units for the one room or zone.
- I. Variable-Air-Volume Terminal Air Units with Reheat Hydronic Coils:
 - 1. Space Temperature: Modulate damper and valve to maintain space temperature set points.

- a. Cooling Temperature: 75 deg F.
 - a. Heating Temperature: 70 deg F.
 - b. Modulate VAV damper actuator from full open to minimum position.
 - b. When VAV damper is at minimum position, modulate reheat coil valve from closed to open to maximum discharge temperature of 100 deg F.
 - c. If space temperature is not maintained at max temperature and damper is at min position, then modulate damper actuator from minimum position to 100% percent open to maintain 95 deg F discharge temperature.
 - d. Reverse the sequence for full heating to full cooling.
- J. Indicate the following on the operator's workstation display terminal:
1. DDC system graphic.
 2. DDC system on-off indication (operating or not operating).
 3. DDC system occupied/unoccupied mode.
 4. Outdoor-air-temperature indication.
 5. Heat Pumps, HP-1 thru 9 for the Toll Booths:
 - a. DDC system on-off indication (operating or not operating).
 - b. Space temperature indication.
 6. Cabinet Unit Heater, Hydronic:
 - a. Space temperature indication.
 - b. Space temperature set point.
 - c. Fan on/off.
 7. Unit Heater, Hydronic:
 - a. Areas Served:
 - b. Space temperature indication.
 - c. Space temperature set point.
 - d. Fan on/off.
 8. Combustion-Air Unit Heater, MUA-1:
 - a. Boiler primary and secondary HW pumps, on/off.
 - b. Boilers, proof and on/off.
 - c. Air temperature to unit indication.
 - d. Space temperature set point.
 - e. Control-valve position.
 - f. Low space temperature alarm.
 - g. Freeze protection pumps
 9. Two-Pipe, Single-Coil, Fan-Coil Unit, FCU-2/3:
 - a. Areas served:
 - b. Space temperature indication.
 - c. Space temperature set point.
 - d. Control-valve position.
 - e. Supply-water temperature indication.
 10. DX Cooling, Hydronic Fan-Coil Unit, FCU-1:
 - a. Area Served

- b. Modes: Heat/Cool
 - c. Space temperature indication.
 - d. Space temperature set point.
 - e. Control-valve position.
11. Split AC-1/2, CU-2/3 serves MTA IT Room:
- a. DDC system on-off indication (operating or not operating).
 - b. Space temperature indication.
 - c. Space temperature set point.
12. Radiators and Convectors, Hydronic:
- a. Space/area served.
 - b. Space temperature indication.
 - c. Space temperature set point
 - d. Control-valve position as percentage open.
13. Variable-Air-Volume Terminal Air Units with Reheat Hydronic Coils:
- a. Space/area served.
 - b. Space temperature indication.
 - c. Space temperature set point.
 - d. Space cooling and heating temperature set point.
 - e. Air-damper position as percentage open.
 - f. Control-valve position as percentage open.

1.5 VENTILATION SEQUENCES

A. Combustion-Air, MAU-1, Makeup Unit Control, Hydronic:

- 1. Initiation: Start fan when Boiler burner starts.
- 2. When boiler has been called to start, the louver, L2 shall open.
- 3. When proof of louver operator (end switch) has open, then MUA-1 shall start and sequence to operate.
- 4. Boiler shall start and sequence through their controls after MUA-1 has started, and louver operator is open.
- 5. Additional sequences for boiler operation - See sequences for boiler operation in Section 15600 "Hot Water Boilers".
- 6. Space Temperature: Modulate control valve to maintain discharge temperature set point of 90 deg F.

B. Exhaust Fan, EF-1 for Toiler Rooms: Fan shall run continuously.

C. Exhaust Fan, EF-2 for Boiler/Mech rooms shall operate at all times.

D. Exhaust Fan, EF-3, Electrical room and storage rooms, EF-3 shall operate at all times.

- E. Exhaust Fan, EF-6/7 shall operate in conjunction with AHU-2. Run both fans in the summer mode, and one fan in the winter mode. Both fans are on roofs of staircases.
- F. Exhaust Fan, EF-5, The exhaust shall operate for AHU-1 during economizer mode.
- G. Exhaust Fan, EF-8, for Radon mitigation shall operate at all times.
- H. Exhaust fan, EF-4, and Supply fan, SF-1 shall operate during purge cycle after FM-200 has been expelled. The purge panel will have switch to manually start and stop both fans as required. Refer to Fire Protection drawings for additional requirements.

PART 2 - PRODUCTS (Not Applicable)

PART 3 - EXECUTION (Not Applicable)

END OF SECTION

SECTION 16050

HANGERS AND SUPPORTS FOR ELECTRICAL SYSTEMS

PART 1 - GENERAL

1.1 SUMMARY

A. Section Includes:

1. Hangers and supports for electrical equipment and systems.
2. Construction requirements for concrete bases.

1.2 ACTION SUBMITTALS

- A. Product Data: For each type of product.
- B. Shop Drawings: Signed and sealed by a qualified professional engineer. For fabrication and installation details for electrical hangers and support systems.
- C. Delegated-Design Submittal: For hangers and supports for electrical systems.
 1. Include design calculations and details of trapeze hangers.

1.3 INFORMATIONAL SUBMITTALS

- A. Coordination Drawings: Reflected ceiling plan(s) and other details, drawn to scale, and coordinated with each other, using input from installers of the items involved:
- B. Seismic Qualification Certificates: For hangers and supports for electrical equipment and systems, accessories, and components, from manufacturer.
- C. Welding certificates.

PART 2 - PRODUCTS

2.1 PERFORMANCE REQUIREMENTS

- A. Delegated Design: Engage a qualified professional engineer to design hanger and support system.
- B. Seismic Performance: Hangers and supports shall withstand the effects of earthquake motions determined according to ASCE/SEI 7.
 1. The term "withstand" means "the supported equipment and systems will remain in place without separation of any parts when subjected to the seismic forces specified and the system will be fully operational after the seismic event."

2. Component Importance Factor: 1.5.

2.2 SUPPORT, ANCHORAGE, AND ATTACHMENT COMPONENTS

- A. Steel Slotted Support Systems: Comply with MFMA-4 factory-fabricated components for field assembly.
 1. Material: Pre-galvanized steel
 2. Channel Width: 1-5/8 inches.
 3. Metallic Coatings: Hot-dip galvanized after fabrication and applied according to MFMA-4.
 4. Protect finishes on exposed surfaces from damage by applying a strippable, temporary protective covering before shipping.
 5. Channel Dimensions: Selected for applicable load criteria.
- B. Conduit and Cable Support Devices: Steel hangers, clamps, and associated fittings, designed for types and sizes of raceway or cable to be supported.
- C. Support for Conductors in Vertical Conduit: Factory-fabricated assembly consisting of threaded body and insulating wedging plug or plugs for non-armored electrical conductors or cables in riser conduits. Plugs shall have number, size, and shape of conductor gripping pieces as required to suit individual conductors or cables supported. Body shall be made of malleable iron.
- D. Structural Steel for Fabricated Supports and Restraints: ASTM A 36/A 36M steel plates, shapes, and bars; black and galvanized.
- E. Mounting, Anchoring, and Attachment Components: Items for fastening electrical items or their supports to building surfaces include the following:
 1. Powder-Actuated Fasteners: Threaded-steel stud, for use in hardened portland cement concrete, steel, or wood, with tension, shear, and pullout capacities appropriate for supported loads and building materials where used.
 2. Mechanical-Expansion Anchors: Insert-wedge-type, zinc-coated steel, for use in hardened portland cement concrete, with tension, shear, and pullout capacities appropriate for supported loads and building materials where used.
 3. Concrete Inserts: Steel or malleable-iron, slotted support system units are similar to MSS Type 18 units and comply with MFMA-4 or MSS SP-58.
 4. Clamps for Attachment to Steel Structural Elements: MSS SP-58 units are suitable for attached structural element.
 5. Through Bolts: Structural type, hex head, and high strength. Comply with ASTM A 325.
 6. Toggle Bolts: All-steel springhead type.
 7. Hanger Rods: Threaded steel.

2.3 FABRICATED METAL EQUIPMENT SUPPORT ASSEMBLIES

- A. Description: Welded or bolted structural-steel shapes, shop or field fabricated to fit dimensions of supported equipment.
- B. Materials: Comply with requirements in Section 05500 "Metal Fabrications" for steel shapes and plates.

PART 3 - EXECUTION

3.1 APPLICATION

- A. Comply with NECA 1 and NECA 101 for application of hangers and supports for electrical equipment and systems unless requirements in this Section are stricter.
- B. Comply with requirements for raceways and boxes specified in Section 16110 "Raceways and Boxes for Electrical Systems."
- C. Maximum Support Spacing and Minimum Hanger Rod Size for Raceway: Space supports for EMTs, and RMCs as required by NFPA 70. Minimum rod size shall be 1/4 inch in diameter.
- D. Multiple Raceways or Cables: Install trapeze-type supports fabricated with steel slotted or other support system, sized so capacity can be increased by at least 25 percent in future without exceeding specified design load limits.
 - 1. Secure raceways and cables to these supports with two-bolt conduit clamps.
- E. Spring-steel clamps designed for supporting single conduits without bolts may be used for 1-1/2-inch and smaller raceways serving branch circuits and communication systems above suspended ceilings and for fastening raceways to trapeze supports.

3.2 SUPPORT INSTALLATION

- A. Comply with NECA 1 and NECA 101 for installation requirements except as specified in this article.
- B. Strength of Support Assemblies: Where not indicated, select sizes of components so strength will be adequate to carry present and future static loads within specified loading limits. Minimum static design load used for strength determination shall be weight of supported components plus 200 lb.
- C. Mounting and Anchorage of Surface-Mounted Equipment and Components: Anchor and fasten electrical items and their supports to building structural elements.
- D. Drill holes for expansion anchors in concrete at locations and to depths that avoid the need for reinforcing bars.

3.3 INSTALLATION OF FABRICATED METAL SUPPORTS

- A. Comply with installation requirements in Section 05500 "Metal Fabrications" for site-fabricated metal supports.
- B. Cut, fit, and place miscellaneous metal supports accurately in location, alignment, and elevation to support and anchor electrical materials and equipment.
- C. Field Welding: Comply with AWS D1.1/D1.1M.

3.4 PAINTING

- A. Galvanized Surfaces: Clean welds, bolted connections, and abraded areas and apply galvanizing-repair paint to comply with ASTM A 780.

END OF SECTION

SECTION 16051SLEEVES AND SLEEVE SEALS FOR ELECTRICAL RACEWAYS AND CABLING

PART 1 - GENERAL

1.1 SUMMARY

A. Section Includes:

1. Sleeves for raceway and cable penetration of non-fire-rated construction walls and floors.
2. Sleeve-seal systems.
3. Sleeve-seal fittings.
4. Grout.
5. Silicone sealants.

B. Related Requirements:

1. Section 07841 "Penetration Firestopping" for penetration firestopping installed in fire-resistance-rated walls, horizontal assemblies, and smoke barriers, with and without penetrating items.

1.2 ACTION SUBMITTALS

A. Product Data: For each type of product.

PART 2 - PRODUCTS

2.1 SLEEVES

A. Wall Sleeves:

1. Steel Pipe Sleeves: ASTM A 53/A 53M, Type E, Grade B, Schedule 40, zinc coated, plain ends.
2. Cast-Iron Pipe Sleeves: Cast or fabricated "wall pipe," equivalent to ductile-iron pressure pipe, with plain ends and integral waterstop unless otherwise indicated.

B. Sleeves for Conduits Penetrating Non-Fire-Rated Gypsum Board Assemblies: Galvanized-steel sheet; 0.0239-inch minimum thickness; round tube closed with welded longitudinal joint, with tabs for screw-fastening the sleeve to the board.

C. Sleeves for Rectangular Openings:

1. Material: Galvanized sheet steel.
2. Minimum Metal Thickness:

- a. For sleeve cross-section rectangle perimeter less than 50 inches and with no side larger than 16 inches, thickness shall be 0.052 inch.
- b. For sleeve cross-section rectangle perimeter 50 inches or more and one or more sides larger than 16 inches, thickness shall be 0.138 inch (3.5 mm).

2.2 SLEEVE-SEAL SYSTEMS

- A. Description: Modular sealing device, designed for field assembly, to fill annular space between sleeve and raceway or cable.
 1. Sealing Elements: EPDM rubber interlocking links shaped to fit surface of pipe. Include type and number required for pipe material and size of pipe.
 2. Pressure Plates: Stainless steel.
 3. Connecting Bolts and Nuts: Stainless steel of length required to secure pressure plates to sealing elements.

2.3 SLEEVE-SEAL FITTINGS

- A. Description: Manufactured plastic, sleeve-type, waterstop assembly made for embedding in concrete slab or wall. Unit shall have plastic or rubber waterstop collar with center opening to match piping OD.

2.4 GROUT

- A. Description: Nonshrink; recommended for interior and exterior sealing openings in non-fire-rated walls or floors.
- B. Standard: ASTM C 1107/C 1107M, Grade B, post-hardening and volume-adjusting, dry, hydraulic-cement grout.
- C. Design Mix: 5000-psi, 28-day compressive strength.
- D. Packaging: Premixed and factory packaged.

2.5 SILICONE SEALANTS

- A. Silicone Sealants: Single-component, silicone-based, neutral-curing elastomeric sealants of grade indicated below.
 1. Grade: Pourable (self-leveling) formulation for openings in floors and other horizontal surfaces that are not fire rated.

PART 3 - EXECUTION

- 3.1 SLEEVE INSTALLATION FOR NON-FIRE-RATED ELECTRICAL PENETRATIONS
- A. Comply with NECA 1.
 - B. Comply with NEMA VE 2 for cable tray and cable penetrations.
 - C. Sleeves for Conduits Penetrating Above-Grade Non-Fire-Rated Concrete and Masonry-Unit Floors and Walls:
 - 1. Interior Penetrations of Non-Fire-Rated Walls and Floors:
 - a. Seal annular space between sleeve and raceway or cable, using joint sealant appropriate for size, depth, and location of joint. Comply with requirements in Section 07900 "Joint Sealers."
 - b. Seal space outside of sleeves with mortar or grout. Pack sealing material solidly between sleeve and wall so no voids remain. Tool exposed surfaces smooth; protect material while curing.
 - 2. Use pipe sleeves unless penetration arrangement requires rectangular sleeved opening.
 - 3. Size pipe sleeves to provide 1/4-inch annular clear space between sleeve and raceway or cable unless sleeve seal is to be installed or unless seismic criteria require different clearance.
 - 4. Install sleeves for wall penetrations unless core-drilled holes or formed openings are used. Install sleeves during erection of walls. Cut sleeves to length for mounting flush with both surfaces of walls. Deburr after cutting.
 - 5. Install sleeves for floor penetrations. Extend sleeves installed in floors 2 inches above finished floor level. Install sleeves during erection of floors.
 - D. Sleeves for Conduits Penetrating Non-Fire-Rated Gypsum Board Assemblies:
 - 1. Use circular metal sleeves unless penetration arrangement requires rectangular sleeved opening.
 - 2. Seal space outside of sleeves with approved joint compound for gypsum board assemblies.
 - E. Roof-Penetration Sleeves: Seal penetration of individual raceways and cables with flexible boot-type flashing units applied in coordination with roofing work.
 - F. Aboveground, Exterior-Wall Penetrations: Seal penetrations using steel pipe sleeves and mechanical sleeve seals. Select sleeve size to allow for 1-inch annular clear space between pipe and sleeve for installing mechanical sleeve seals.
 - G. Underground, Exterior-Wall and Floor Penetrations: Install cast-iron pipe sleeves. Size sleeves to allow for 1-inch annular clear space between raceway or cable and sleeve for installing sleeve-seal system.

3.2 SLEEVE-SEAL-SYSTEM INSTALLATION

- A. Install sleeve-seal systems in sleeves in exterior concrete walls and slabs-on-grade at raceway entries into building.
- B. Install type and number of sealing elements recommended by manufacturer for raceway or cable material and size. Position raceway or cable in center of sleeve. Assemble mechanical sleeve seals and install in annular space between raceway or cable and sleeve. Tighten bolts against pressure plates that cause sealing elements to expand and make watertight seal.

3.3 SLEEVE-SEAL-FITTING INSTALLATION

- A. Install sleeve-seal fittings in new walls and slabs as they are constructed.
- B. Assemble fitting components of length to be flush with both surfaces of concrete slabs and walls. Position waterstop flange to be centered in concrete slab or wall.
- C. Secure nailing flanges to concrete forms.
- D. Using grout, seal the space around outside of sleeve-seal fittings.

END OF SECTION

SECTION 16052

IDENTIFICATION FOR ELECTRICAL SYSTEMS

PART 1 - GENERAL

1.1 SUMMARY

A. Section Includes:

1. Identification of power and control cables.
2. Identification for conductors.
3. Underground-line warning tape.
4. Warning labels and signs.
5. Instruction signs.
6. Equipment identification labels, including arc-flash warning labels.
7. Miscellaneous identification products.

1.2 ACTION SUBMITTALS

- A. Product Data: For each type of product.
- B. Delegated-Design Submittal: For arc-flash hazard study.

PART 2 - PRODUCTS

2.1 PERFORMANCE REQUIREMENTS

- A. Comply with ASME A13.1 and IEEE C2.
- B. Comply with NFPA 70 and NFPA 70E.
- C. Comply with 29 CFR 1910.144 and 29 CFR 1910.145.
- D. Comply with ANSI Z535.4 for safety signs and labels.
- E. Adhesive-attached labeling materials, including label stocks, laminating adhesives, and inks used by label printers, shall comply with UL 969.

2.2 LABELS

- A. Vinyl Labels for Raceways Carrying Circuits at 600 V or Less: Preprinted, flexible labels laminated with a clear, weather- and chemical-resistant coating and matching wraparound clear adhesive tape for securing label ends.
- B. Self-Adhesive Labels:

1. Preprinted, 3-mil-thick, polyester flexible label with acrylic pressure-sensitive adhesive.
2. Polyester, thermal, transfer-printed, 3-mil-thick, multicolor, weather- and UV-resistant, pressure-sensitive adhesive labels, configured for display on front cover, door, or other access to equipment unless otherwise indicated.
 - a. Nominal Size: 3.5-by-5-inch.

2.3 TAPES AND STENCILS:

- A. Marker Tapes: Vinyl or vinyl-cloth, self-adhesive wraparound type, with circuit identification legend machine printed by thermal transfer or equivalent process.
- B. Self-Adhesive Vinyl Tape: Colored, heavy duty, waterproof, fade resistant; not less than 3 mils thick by 1 to 2 inches wide; compounded for outdoor use.
- C. Floor Marking Tape: 2-inch-wide, 5-mil pressure-sensitive vinyl tape, with black and white stripes and clear vinyl overlay.
- D. Underground-Line Warning Tape
 1. Tape:
 - a. Recommended by manufacturer for the method of installation and suitable to identify and locate underground electrical and communications utility lines.
 - b. Printing on tape shall be permanent and shall not be damaged by burial operations.
 - c. Tape material and ink shall be chemically inert and not subject to degradation when exposed to acids, alkalis, and other destructive substances commonly found in soils.
 2. Color and Printing:
 - a. Comply with ANSI Z535.1, ANSI Z535.2, ANSI Z535.3, ANSI Z535.4, and ANSI Z535.5.
 - b. Inscriptions for Red-Colored Tapes: "ELECTRIC LINE, HIGH VOLTAGE"
 - c. Inscriptions for Orange-Colored Tapes: "TELEPHONE CABLE, CATV CABLE, COMMUNICATIONS CABLE, OPTICAL FIBER CABLE".
 3. Tag: Type I:
 - a. Pigmented polyolefin, bright colored, continuous-printed on one side with the inscription of the utility, compounded for direct-burial service.
 - b. Width: 3 inches.
 - c. Thickness: 4 mils. Weight: 18.5 lb/1000 sq. ft.
 - d. Tensile according to ASTM D 882: 30 lbf and 2500 psi.

2.4 Signs

A. Baked-Enamel Signs:

1. Preprinted aluminum signs, punched or drilled for fasteners, with colors, legend, and size required for application.
2. 1/4-inch grommets in corners for mounting.
3. Nominal Size: 7 by 10 inches.

B. Metal-Backed Butyrate Signs:

1. Weather-resistant, nonfading, preprinted, cellulose-acetate butyrate signs, with 0.0396-inch galvanized-steel backing and with colors, legend, and size required for application.
2. 1/4-inch grommets in corners for mounting.
3. Nominal Size: 10 by 14 inches.

C. Laminated Acrylic or Melamine Plastic Signs:

1. Engraved legend.
2. Thickness:
 - a. For signs up to 20 sq. inches, minimum 1/16-inch.
 - b. For signs larger than 20 sq. inches, 1/8 inch thick.
 - c. Engraved legend with black letters on white face.
 - d. Punched or drilled for mechanical fasteners.
 - e. Framed with mitered acrylic molding and arranged for attachment at applicable equipment.

2.5 CABLE TIES

A. General-Purpose Cable Ties: Fungus inert, self-extinguishing, one piece, self-locking, Type 6/6 nylon.

1. Minimum Width: 3/16 inch.
2. Tensile Strength at 73 deg F according to ASTM D 638: 12,000 psi.
3. Temperature Range: Minus 40 to plus 185 deg F.
4. Color: Black, except where used for color-coding.

B. UV-Stabilized Cable Ties: Fungus inert, designed for continuous exposure to exterior sunlight, self-extinguishing, one piece, self-locking, Type 6/6 nylon.

1. Minimum Width: 3/16 inch.
2. Tensile Strength at 73 deg F according to ASTM D 638: 12,000 psi.
3. Temperature Range: Minus 40 to plus 185 deg F.
4. Color: Black.

C. Plenum-Rated Cable Ties: Self-extinguishing, UV stabilized, one piece, self-locking.

1. Minimum Width: 3/16 inch.

2. Tensile Strength at 73 deg F according to ASTM D 638: 7000 psi.
3. UL 94 Flame Rating: 94V-0.
4. Temperature Range: Minus 50 to plus 284 deg F.
5. Color: Black.

2.6 MISCELLANEOUS IDENTIFICATION PRODUCTS

- A. Fasteners for Labels and Signs: Self-tapping, stainless-steel screws or stainless-steel machine screws with nuts and flat and lock washers.

PART 3 - EXECUTION

3.1 INSTALLATION

- A. Install identification materials and devices at locations for most convenient viewing without interference with operation and maintenance of equipment.
- B. Apply identification devices to surfaces that require finish after completing finish work.
- C. Attach signs and plastic labels that are not self-adhesive type with mechanical fasteners appropriate to the location and substrate.
- D. Attach plastic raceway and cable labels that are not self-adhesive type with clear vinyl tape, with adhesive appropriate to the location and substrate.
- E. Cable Ties: For attaching tags. Use general-purpose type, except as listed below:
 1. Outdoors: UV-stabilized nylon.
 2. In Spaces Handling Environmental Air: Plenum rated.
- F. During backfilling of trenches, install continuous underground-line warning tape directly above cable or raceway at 6 to 8 inches below finished grade. Use multiple tapes where width of multiple lines installed in a common trench or concrete envelope exceeds 16 inches overall.

3.2 IDENTIFICATION SCHEDULE

- A. Power-Circuit Conductor Identification, 600 V or Less: For conductors in vaults, pull and junction boxes, manholes, and handholes, use color-coding conductor tape to identify the phase.
 1. Color-Coding for Phase- and Voltage-Level Identification, 600 V or Less: Use industry standard colors for ungrounded service, feeder and branch-circuit conductors.
 - a. Field-Applied, Color-Coding Conductor Tape: Apply in half-lapped turns for a minimum distance of 6 inches from terminal points and in boxes where splices or taps are made. Apply last two turns of tape with no tension

to prevent possible unwinding. Locate bands to avoid obscuring factory cable markings.

- B. Control-Circuit Conductor Identification: For conductors and cables in pull and junction boxes, use self-adhesive, self-laminating polyester labels with the conductor or cable designation, origin, and destination.
- C. Control-Circuit Conductor Termination Identification: For identification at terminations, provide self-adhesive, self-laminating polyester labels with the conductor designation.
- D. Conductors to Be Extended in the Future: Attach write-on tags to conductors and list source.
- E. Auxiliary Electrical Systems Conductor Identification: Identify field-installed alarm, control, and signal connections.
 - 1. Identify conductors, cables, and terminals in enclosures and at junctions, terminals, and pull points. Identify by system and circuit designation.
 - 2. Use system of marker-tape designations that is uniform and consistent with system used by manufacturer for factory-installed connections.
 - 3. Coordinate identification with Project Drawings, manufacturer's wiring diagrams, and operation and maintenance manual.
- F. Locations of Underground Lines: Identify with underground-line warning tape for power, lighting, communication, and control wiring and optical-fiber cable.
 - 1. Limit use of underground-line warning tape to direct-buried cables.
 - 2. Install underground-line warning tape for direct-buried cables and cables in raceways.
- G. Workspace Indication: Install floor marking tape to show working clearances in the direction of access to live parts. Workspace shall comply with NFPA 70 and 29 CFR 1926.403 unless otherwise indicated. Do not install at flush-mounted panelboards and similar equipment in finished spaces.
- H. Warning Labels for Indoor Cabinets, Boxes, and Enclosures for Power and Lighting: Self-adhesive warning labels or Baked-enamel warning signs.
 - 1. Comply with 29 CFR 1910.145.
 - 2. Identify system voltage with black letters on an orange background.
 - 3. Apply to exterior of door, cover, or other access.
 - 4. For equipment with multiple power or control sources, apply to door or cover of equipment, including, but not limited to, the following:
 - a. Power-transfer switches.
 - b. Controls with external control power connections.
- I. Operating Instruction Signs: Install instruction signs to facilitate proper operation and maintenance of electrical systems and items to which they connect. Install instruction

signs with approved legend where instructions are needed for system or equipment operation.

- J. Emergency Operating Instruction Signs: Install instruction signs with white legend on a red background with minimum 3/8-inch-high letters for emergency instructions at equipment used for power transfer.
- K. Equipment Identification Labels: On each unit of equipment, install unique designation label that is consistent with wiring diagrams, schedules, and operation and maintenance manual.
 - 1. Labeling Instructions:
 - a. Indoor Equipment: Self-adhesive label, Self-adhesive, engraved, laminated acrylic or melamine plastic label Engraved, laminated acrylic or melamine plastic label, punched or drilled for mechanical fasteners. Unless otherwise indicated, provide a single line of text with 1/2-inch-high letters on 1-1/2-inch-high label; where two lines of text are required, use labels 2 inches high.
 - b. Outdoor Equipment: Engraved, laminated acrylic or melamine label 4 inches high.
 - c. Elevated Components: Increase sizes of labels and letters to those appropriate for viewing from the floor.
 - d. Unless labels are provided with self-adhesive means of attachment, fasten them with appropriate mechanical fasteners that do not change the NEMA or NRTL rating of the enclosure.

END OF SECTION

SECTION 16110

RACEWAYS AND BOXES FOR ELECTRICAL SYSTEMS

PART 1 - GENERAL

1.1 SUMMARY

A. Section Includes:

1. Metal conduits, tubing, and fittings.
2. Nonmetal conduits, tubing, and fittings.
3. Metal wireways and auxiliary gutters.
4. Surface raceways.
5. Boxes, enclosures, and cabinets.
6. Handholes and boxes for exterior underground cabling.

B. Related Requirements:

1. Section 16111 "Underground Ducts and Raceways for Electrical Systems" for exterior ductbanks, manholes, and underground utility construction.

1.2 ACTION SUBMITTALS

- A. Product Data: For surface raceways, wireways and fittings, floor boxes, hinged-cover enclosures, and cabinets.
- B. Shop Drawings: For custom enclosures and cabinets. Include plans, elevations, sections, and attachment details.

1.3 INFORMATIONAL SUBMITTALS

- A. Coordination Drawings: Conduit routing plans, drawn to scale, on which the following items are shown and coordinated with each other, using input from installers of items involved:
1. Structural members in paths of conduit groups with common supports.
 2. HVAC and plumbing items and architectural features in paths of conduit groups with common supports.
- B. Seismic Qualification Certificates: For enclosures, cabinets, and conduit racks and their mounting provisions including those for internal components, from manufacturer.

PART 2 - PRODUCTS

2.1 METAL CONDUITS, TUBING, AND FITTINGS

- A. Listing and Labeling: Metal conduits, tubing, and fittings shall be listed and labeled as defined in NFPA 70, by a qualified testing agency, and marked for intended location and application.
- B. GRC: Comply with ANSI C80.1 and UL 6.
- C. ARC: Comply with ANSI C80.5 and UL 6A.
- D. IMC: Comply with ANSI C80.6 and UL 1242.
- E. PVC-Coated Steel Conduit: PVC-coated rigid steel conduit.
 - 1. Comply with NEMA RN 1.
 - 2. Coating Thickness: 0.040 inch, minimum.
- F. EMT: Comply with ANSI C80.3 and UL 797.
- G. FMC: Comply with UL 1; zinc-coated steel.
- H. LFMC: Flexible steel conduit with PVC jacket and complying with UL 360.
- I. Fittings for Metal Conduit: Comply with NEMA FB 1 and UL 514B.
 - 1. Conduit Fittings for Hazardous (Classified) Locations: Comply with UL 886 and NFPA 70.
 - 2. Fittings for EMT:
 - a. Material: Steel.
 - b. Type: Setscrew.
 - 3. Expansion Fittings: PVC or steel to match conduit type, complying with UL 651, rated for environmental conditions where installed, and including flexible external bonding jumper.
 - 4. Coating for Fittings for PVC-Coated Conduit: Minimum thickness of 0.040 inch with overlapping sleeves protecting threaded joints.
- J. Joint Compound for GRC, or ARC: Approved, as defined in NFPA 70, by authorities having jurisdiction for use in conduit assemblies, and compounded for use to lubricate and protect threaded conduit joints from corrosion and to enhance their conductivity.

2.2 NONMETALLIC CONDUITS, TUBING, AND FITTINGS

- A. Listing and Labeling: Nonmetallic conduits, tubing, and fittings shall be listed and labeled as defined in NFPA 70, by a qualified testing agency, and marked for intended location and application.

- B. ENT: Comply with NEMA TC 13 and UL 1653.
- C. RNC: Type EPC-40-PVC, complying with NEMA TC 2 and UL 651 unless otherwise indicated.
- D. LFNC: Comply with UL 1660.
- E. Continuous HDPE: Comply with UL 651B.
- F. Coilable HDPE: Preassembled with conductors or cables, and complying with ASTM D 3485.
- G. Fittings for ENT and RNC: Comply with NEMA TC 3; match to conduit or tubing type and material.
- H. Fittings for LFNC: Comply with UL 514B.
- I. Solvents and Adhesives: As recommended by conduit manufacturer.

2.3 METAL WIREWAYS AND AUXILIARY GUTTERS

- A. Description: Sheet metal, complying with UL 870 and NEMA 250, Type 1, Type 3R, Type 4 and Type 12 unless otherwise indicated, and sized according to NFPA 70.
 - 1. Metal wireways installed outdoors shall be listed and labeled as defined in NFPA 70, by a qualified testing agency, and marked for intended location and application.
- B. Fittings and Accessories: Include covers, couplings, offsets, elbows, expansion joints, adapters, hold-down straps, end caps, and other fittings to match and mate with wireways as required for complete system.

2.4 NONMETALLIC WIREWAYS AND AUXILIARY GUTTERS

- A. Listing and Labeling: Nonmetallic wireways and auxiliary gutters shall be listed and labeled as defined in NFPA 70, by a qualified testing agency, and marked for intended location and application.
- B. Description: Fiberglass polyester, extruded and fabricated to required size and shape, without holes or knockouts. Cover shall be gasketed with oil-resistant gasket material and fastened with captive screws treated for corrosion resistance. Connections shall be flanged and have stainless-steel screws and oil-resistant gaskets.
- C. Description: PVC, extruded and fabricated to required size and shape, and having snap-on cover, mechanically coupled connections, and plastic fasteners.
- D. Fittings and Accessories: Couplings, offsets, elbows, expansion joints, adapters, hold-down straps, end caps, and other fittings shall match and mate with wireways as required for complete system.

- E. Solvents and Adhesives: As recommended by conduit manufacturer.

2.5 SURFACE RACEWAYS

- A. Listing and Labeling: Surface raceways and tele-power poles shall be listed and labeled as defined in NFPA 70, by a qualified testing agency, and marked for intended location and application.
- B. Surface Metal Raceways: Galvanized steel with snap-on covers complying with UL 5.

2.6 BOXES, ENCLOSURES, AND CABINETS

- A. General Requirements for Boxes, Enclosures, and Cabinets: Boxes, enclosures, and cabinets installed in wet locations shall be listed for use in wet locations.
- B. Sheet Metal Outlet and Device Boxes: Comply with NEMA OS 1 and UL 514A.
- C. Cast-Metal Outlet and Device Boxes: Comply with NEMA FB 1, ferrous alloy, Type FD, with gasketed cover.
- D. Nonmetallic Outlet and Device Boxes: Comply with NEMA OS 2 and UL 514C.
- E. Metal Floor Boxes:
 - 1. Material: Cast metal.
 - 2. Type: Fully adjustable.
 - 3. Shape: Rectangular.
 - 4. Listing and Labeling: Metal floor boxes shall be listed and labeled as defined in NFPA 70, by a qualified testing agency, and marked for intended location and application.
- F. Nonmetallic Floor Boxes: Nonadjustable, round.
 - 1. Listing and Labeling: Nonmetallic floor boxes shall be listed and labeled as defined in NFPA 70, by a qualified testing agency, and marked for intended location and application.
- G. Luminaire Outlet Boxes: Nonadjustable, designed for attachment of luminaire weighing 50 lb. Outlet boxes designed for attachment of luminaires weighing more than 50 lb shall be listed and marked for the maximum allowable weight.
- H. Paddle Fan Outlet Boxes: Nonadjustable, designed for attachment of paddle fan weighing 70 lb.
 - 1. Listing and labeling: Paddle fan outlet boxes shall be listed and labeled as defined in NFPA 70, by a qualified testing agency, and marked for intended location and application.
- I. Small Sheet Metal Pull and Junction Boxes: NEMA OS 1.

- J. Cast-Metal Access, Pull, and Junction Boxes: Comply with NEMA FB 1 and UL 1773, cast aluminum with gasketed cover.
- K. Box extensions used to accommodate new building finishes shall be of same material as recessed box.
- L. Device Box Dimensions: 4 inches square by 2-1/8 inches deep.
- M. Gangable boxes are prohibited.
- N. Hinged-Cover Enclosures: Comply with UL 50 and NEMA 250, Type 1, Type 3R, Type 4 and Type 12 with continuous-hinge cover with flush latch unless otherwise indicated.
 - 1. Metal Enclosures: Steel, finished inside and out with manufacturer's standard enamel.
 - 2. Nonmetallic Enclosures: Plastic or Fiberglass.
 - 3. Interior Panels: Steel; all sides finished with manufacturer's standard enamel.
- O. Cabinets:
 - 1. NEMA 250, Type 1, Type 3R, and Type 12 galvanized-steel box with removable interior panel and removable front, finished inside and out with manufacturer's standard enamel.
 - 2. Hinged door in front cover with flush latch and concealed hinge.
 - 3. Key latch to match panelboards.
 - 4. Metal barriers to separate wiring of different systems and voltage.
 - 5. Accessory feet where required for freestanding equipment.
 - 6. Nonmetallic cabinets shall be listed and labeled as defined in NFPA 70, by a qualified testing agency, and marked for intended location and application.

2.7 HANDHOLES AND BOXES FOR EXTERIOR UNDERGROUND WIRING

- A. General Requirements for Handholes and Boxes:
 - 1. Boxes and handholes for use in underground systems shall be designed and identified as defined in NFPA 70, for intended location and application.
 - 2. Boxes installed in wet areas shall be listed and labeled as defined in NFPA 70, by a qualified testing agency, and marked for intended location and application.
- B. Polymer-Concrete Handholes and Boxes with Polymer-Concrete Cover: Molded of sand and aggregate, bound together with polymer resin, and reinforced with steel, fiberglass, or a combination of the two.
 - 1. Configuration: Designed for flush burial with open bottom unless otherwise indicated.
 - 2. Cover: Weatherproof, secured by tamper-resistant locking devices and having structural load rating consistent with enclosure and handhole location.
 - 3. Cover Finish: Nonskid finish shall have a minimum coefficient of friction of 0.50.
 - 4. Cover Legend: Molded lettering, "ELECTRIC".

5. Conduit Entrance Provisions: Conduit-terminating fittings shall mate with entering ducts for secure, fixed installation in enclosure wall.

PART 3 - EXECUTION

3.1 RACEWAY APPLICATION

- A. Outdoors: Apply raceway products as specified below unless otherwise indicated:

1. Exposed Conduit: GRC, and RNC, Type EPC-40-PVC.
2. Concealed Conduit, Aboveground: GRC, and RNC, Type EPC-40-PVC.
3. Underground Conduit: RNC, Type EPC-40-PVC, concrete encased.
4. Connection to Vibrating Equipment (Including Transformers and Hydraulic, Pneumatic, Electric Solenoid, or Motor-Driven Equipment): LFMC and LFNC.
5. Boxes and Enclosures, Aboveground: NEMA 250, Type 3R and Type 4.

- B. Indoors: Apply raceway products as specified below unless otherwise indicated.

1. Exposed, Not Subject to Physical Damage: EMT.
2. Exposed, Not Subject to Severe Physical Damage: EMT.
3. Exposed and Subject to Severe Physical Damage: GRC. Raceway locations include the following:
 - a. Loading dock.
 - b. Corridors used for traffic of mechanized carts, forklifts, and pallet-handling units.
 - c. Mechanical rooms.
4. Concealed in Ceilings and Interior Walls and Partitions: EMT.
5. Connection to Vibrating Equipment (Including Transformers and Hydraulic, Pneumatic, Electric Solenoid, or Motor-Driven Equipment): FMC, except use LFMC in damp or wet locations.
6. Damp or Wet Locations: GRC.
7. Boxes and Enclosures: NEMA 250, Type 1, except use NEMA 250, Type 4 stainless steel or nonmetallic in institutional and commercial kitchens and damp or wet locations.

- C. Minimum Raceway Size: 3/4-inch trade size.

- D. Raceway Fittings: Compatible with raceways and suitable for use and location.

1. Rigid Steel Conduit: Use threaded rigid steel conduit fittings unless otherwise indicated. Comply with NEMA FB 2.10.
2. PVC Externally Coated, Rigid Steel Conduits: Use only fittings listed for use with this type of conduit. Patch and seal all joints, nicks, and scrapes in PVC coating after installing conduits and fittings. Use sealant recommended by fitting manufacturer and apply in thickness and number of coats recommended by manufacturer.
3. EMT: Use setscrew, steel fittings. Comply with NEMA FB 2.10.

4. Flexible Conduit: Use only fittings listed for use with flexible conduit. Comply with NEMA FB 2.20.
- E. Do not install aluminum conduits, boxes, or fittings in contact with concrete or earth.
- F. Install surface raceways only where indicated on Drawings.
- G. Do not install non-metallic conduit where ambient temperature exceeds 120 deg F.

3.2 INSTALLATION

- A. Comply with NECA 1 and NECA 101 for installation requirements except where requirements on Drawings or in this article are stricter. Comply with NECA 102 for aluminum conduits. Comply with NFPA 70 limitations for types of raceways allowed in specific occupancies and number of floors.
- B. Keep raceways at least 6 inches away from parallel runs of flues and steam or hot-water pipes. Install horizontal raceway runs above water and steam piping.
- C. Comply with requirements in Section 16050 "Hangers and Supports for Electrical Systems" for hangers and supports.
- D. Arrange stub-ups so curved portions of bends are not visible above finished slab.
- E. Install no more than the equivalent of three 90-degree bends in any conduit run except for control wiring conduits, for which fewer bends are allowed. Support within 12 inches of changes in direction.
- F. Conceal conduit and EMT within finished walls, ceilings, and floors unless otherwise indicated. Install conduits parallel or perpendicular to building lines.
- G. Support conduit within 12 inches of enclosures to which attached.
- H. Raceways Embedded in Slabs:
 1. Run conduit larger than 1-inch trade size, parallel or at right angles to main reinforcement. Where at right angles to reinforcement, place conduit close to slab support. Secure raceways to reinforcement at maximum 10-foot intervals.
 2. Arrange raceways to cross building expansion joints at right angles with expansion fittings.
 3. Arrange raceways to keep a minimum of 1 inch of concrete cover in all directions.
 4. Do not embed threadless fittings in concrete unless specifically approved by Architect for each specific location.
 5. Change from RNC, Type EPC-40-PVC, to GRC before rising above floor.
- I. Stub-ups to Above Recessed Ceilings:
 1. Use EMT or RMC for raceways.
 2. Use a conduit bushing or insulated fitting to terminate stub-ups not terminated in hubs or in an enclosure.

- J. Threaded Conduit Joints, Exposed to Wet, Damp, Corrosive, or Outdoor Conditions: Apply listed compound to threads of raceway and fittings before making up joints. Follow compound manufacturer's written instructions.
- K. Coat field-cut threads on PVC-coated raceway with a corrosion-preventing conductive compound prior to assembly.
- L. Raceway Terminations at Locations Subject to Moisture or Vibration: Use insulating bushings to protect conductors including conductors smaller than No. 4 AWG.
- M. Terminate threaded conduits into threaded hubs or with locknuts on inside and outside of boxes or cabinets. Install bushings on conduits up to 1-1/4-inch trade size and insulated throat metal bushings on 1-1/2-inch trade size and larger conduits terminated with locknuts. Install insulated throat metal grounding bushings on service conduits.
- N. Install pull wires in empty raceways. Use polypropylene or monofilament plastic line with not less than 200-lb tensile strength. Leave at least 12 inches of slack at each end of pull wire. Cap underground raceways designated as spare above grade alongside raceways in use.
- O. Surface Raceways:
 - 1. Install surface raceway with a minimum 2-inch radius control at bend points.
 - 2. Secure surface raceway with screws or other anchor-type devices at intervals not exceeding 48 inches and with no less than two supports per straight raceway section. Support surface raceway according to manufacturer's written instructions. Tape and glue are not acceptable support methods.
- P. Install raceway sealing fittings at accessible locations according to NFPA 70 and fill them with listed sealing compound. For concealed raceways, install each fitting in a flush steel box with a blank cover plate having a finish similar to that of adjacent plates or surfaces.
- Q. Install devices to seal raceway interiors at accessible locations. Locate seals so no fittings or boxes are between the seal and the following changes of environments. Seal the interior of all raceways at the following points:
 - 1. Where conduits pass from warm to cold locations, such as boundaries of refrigerated spaces.
 - 2. Where an underground service raceway enters a building or structure.
 - 3. Where otherwise required by NFPA 70.
- R. Expansion-Joint Fittings:
 - 1. Install in each run of aboveground RNC that is located where environmental temperature change may exceed 30 deg F and that has straight-run length that exceeds 25 feet.
 - 2. Install type and quantity of fittings that accommodate temperature change listed for each of the following locations:

- a. Outdoor Locations Not Exposed to Direct Sunlight: 125 deg F temperature change.
 - b. Outdoor Locations Exposed to Direct Sunlight: 155 deg F temperature change.
 - c. Indoor Spaces Connected with Outdoors without Physical Separation: 125 deg F temperature change.
 - d. Attics: 135 deg F temperature change.
3. Install fitting(s) that provide expansion and contraction for at least 0.00041 inch per foot of length of straight run per degree F of temperature change for PVC conduits.
 4. Install expansion fittings at all locations where conduits cross building or structure expansion joints.
 5. Install each expansion-joint fitting with position, mounting, and piston setting selected according to manufacturer's written instructions for conditions at specific location at time of installation. Install conduit supports to allow for expansion movement.
- S. Flexible Conduit Connections: Comply with NEMA RV 3. Use a maximum of 72 inches of flexible conduit for recessed and semi-recessed luminaires, equipment subject to vibration, noise transmission, or movement; and for transformers and motors.
1. Use LFMC in damp or wet locations subject to severe physical damage.
 2. Use LFMC or LFNC in damp or wet locations not subject to severe physical damage.
- T. Mount boxes at heights indicated on Drawings. If mounting heights of boxes are not individually indicated, give priority to ADA requirements. Install boxes with height measured to center of box unless otherwise indicated.
- U. Recessed Boxes in Masonry Walls: Saw-cut opening for box in center of cell of masonry block, and install box flush with surface of wall. Prepare block surfaces to provide a flat surface for a raintight connection between the box and cover plate or the supported equipment and box.
- V. Horizontally separate boxes mounted on opposite sides of walls so they are not in the same vertical channel.
- W. Locate boxes so that cover or plate will not span different building finishes.
- X. Support boxes of three gangs or more from more than one side by spanning two framing members or mounting on brackets specifically designed for the purpose.
- Y. Fasten junction and pull boxes to or support from building structure. Do not support boxes by conduits.
- Z. Set metal floor boxes level and flush with finished floor surface.
- AA. Set nonmetallic floor boxes level. Trim after installation to fit flush with finished floor surface.

3.3 INSTALLATION OF UNDERGROUND CONDUIT

A. Direct-Buried Conduit:

1. Excavate trench bottom to provide firm and uniform support for conduit. Prepare trench bottom as specified in the Civil specifications for pipe less than 6 inches in nominal diameter.
2. Install backfill as specified in the Civil specifications
3. After installing conduit, backfill and compact. Start at tie-in point, and work toward end of conduit run, leaving conduit at end of run free to move with expansion and contraction as temperature changes during this process. Firmly hand tamp backfill around conduit to provide maximum supporting strength. After placing controlled backfill to within 12 inches of finished grade, make final conduit connection at end of run and complete backfilling with normal compaction as specified in Civil specifications.
4. Install manufactured duct elbows for stub-up at poles and equipment and at building entrances through floor unless otherwise indicated. Encase elbows for stub-up ducts throughout length of elbow.
5. Install manufactured rigid steel conduit elbows for stub-ups at poles and equipment and at building entrances through floor.
 - a. Couple steel conduits to ducts with adapters designed for this purpose, and encase coupling with 3 inches of concrete for a minimum of 12 inches on each side of the coupling.
 - b. For stub-ups at equipment mounted on outdoor concrete bases and where conduits penetrate building foundations, extend steel conduit horizontally a minimum of 60 inches from edge of foundation or equipment base. Install insulated grounding bushings on terminations at equipment.
6. Underground Warning Tape: Comply with requirements in Section 16052 "Identification for Electrical Systems."

3.4 INSTALLATION OF UNDERGROUND HANDHOLES AND BOXES

- A. Install handholes and boxes level and plumb and with orientation and depth coordinated with connecting conduits to minimize bends and deflections required for proper entrances.
- B. Unless otherwise indicated, support units on a level bed of crushed stone or gravel, graded from 1/2-inch sieve to No. 4 sieve and compacted to same density as adjacent undisturbed earth.
- C. Elevation: In paved areas, set so cover surface will be flush with finished grade. Set covers of other enclosures 1 inch above finished grade.
- D. Install handholes with bottom below frost line, below grade.
- E. Field-cut openings for conduits according to enclosure manufacturer's written instructions. Cut wall of enclosure with a tool designed for material to be cut. Size holes

for terminating fittings to be used, and seal around penetrations after fittings are installed.

3.5 SLEEVE AND SLEEVE-SEAL INSTALLATION FOR ELECTRICAL PENETRATIONS

- A. Install sleeves and sleeve seals at penetrations of exterior floor and wall assemblies. Comply with requirements in Section 16051 "Sleeves and Sleeve Seals for Electrical Raceways and Cabling."

3.6 FIRESTOPPING

- A. Install firestopping at penetrations of fire-rated floor and wall assemblies. Comply with requirements in Section 07841 "Penetration Firestopping."

3.7 PROTECTION

- A. Protect coatings, finishes, and cabinets from damage and deterioration.
 - 1. Repair damage to galvanized finishes with zinc-rich paint recommended by manufacturer.
 - 2. Repair damage to PVC coatings or paint finishes with matching touchup coating recommended by manufacturer.

END OF SECTION

SECTION 16111

UNDERGROUND DUCTS AND RACEWAYS FOR ELECTRICAL SYSTEMS

PART 1 - GENERAL

1.1 SUMMARY

A. Section Includes:

1. Direct-buried conduit, ducts, and duct accessories.
2. Concrete-encased conduit, ducts, and duct accessories.

1.2 ACTION SUBMITTALS

A. Product Data: For ducts and conduits, duct-bank materials and their accessories.

B. Shop Drawings:

1. Precast or Factory-Fabricated Underground Utility Structures:
 - a. Include plans, elevations, sections, details, attachments to other work, and accessories.
 - b. Include duct entry provisions, including locations and duct sizes.

1.3 INFORMATIONAL SUBMITTALS

- A. Duct-Bank Coordination Drawings: Show duct profiles, locations of expansion fittings, and coordination with other utilities and underground structures on Drawings signed and sealed by a qualified professional engineer.
- B. Qualification Data: For professional engineer and testing agency responsible for testing nonconcrete handholes and boxes.
- C. Source quality-control reports.
- D. Field quality-control reports.

1.4 QUALITY ASSURANCE

- A. Testing Agency Qualifications: Qualified according to ASTM E 329 for testing indicated.

1.5 FIELD CONDITIONS

- A. Interruption of Existing Electrical Service: Do not interrupt electrical service to facilities occupied by Owner or others unless permitted by the Owner, and then only after arranging to provide temporary electrical service.
- B. Ground Water: Assume ground-water level is 36 inches below ground surface unless a higher water table is noted on Drawings.

PART 2 - PRODUCTS

2.1 GENERAL REQUIREMENTS FOR DUCTS AND RACEWAYS

- A. Comply with ANSI C2.

2.2 CONDUIT

- A. Rigid Steel Conduit: Galvanized. Comply with ANSI C80.1.
- B. RNC: NEMA TC 2, Type EPC-40-PVC, UL 651, with matching fittings by same manufacturer as the conduit, complying with NEMA TC 3 and UL 514B.

2.3 NONMETALLIC DUCTS AND DUCT ACCESSORIES

- A. Underground Plastic Utilities Duct: NEMA TC 2, UL 651, ASTM F 512, Type EPC-40, with matching fittings complying with NEMA TC 3 by same manufacturer as the duct.
- B. Solvents and Adhesives: As recommended by conduit manufacturer.
- C. Duct Accessories:
 - 1. Duct Separators: Factory-fabricated rigid PVC interlocking spacers.
 - 2. Warning Tape: Underground-line warning tape specified in Section 16052 "Identification for Electrical Systems."

PART 3 - EXECUTION

3.1 UNDERGROUND DUCT APPLICATION

- A. Ducts for Electrical Cables More than 600 V: RNC, NEMA Type EPC-40-PVC, in concrete-encased duct bank unless otherwise indicated.
- B. Ducts for Electrical Feeders 600 V and Less: RNC, NEMA Type EPC-40-PVC, in direct-buried duct bank unless otherwise indicated.

- C. Ducts for Electrical Branch Circuits: RNC, NEMA Type EPC-40-PVC, in direct-buried duct bank unless otherwise indicated.
- D. Underground Ducts Crossing Paved Paths, Walks, and Driveways, Roadways: RNC, NEMA Type EPC-40-PVC, encased in reinforced concrete.

3.2 EARTHWORK

- A. Excavation and Backfill: Comply with the Civil specifications but do not use heavy-duty, hydraulic-operated, compaction equipment.
- B. Restore areas disturbed by trenching, storing of dirt, cable laying, and other work. Restore vegetation and include necessary topsoiling, fertilizing, liming, seeding, sodding, sprigging, and mulching. Comply with the Civil specifications
- C. Cut and patch existing pavement in the path of underground ducts and utility structures according to the "Cutting and Patching" Article in the Civil specifications.

3.3 DUCT INSTALLATION

- A. Install ducts according to NEMA TCB 2.
- B. Slope: Pitch ducts a minimum slope of 1:300 down toward manholes and handholes and away from buildings and equipment. Slope ducts from a high point in runs between two manholes, to drain in both directions.
- C. Curves and Bends: Use 5-degree angle couplings for small changes in direction. Use manufactured long sweep bends with a minimum radius of 48 inches, both horizontally and vertically, at other locations unless otherwise indicated.
- D. Joints: Use solvent-cemented joints in ducts and fittings and make watertight according to manufacturer's written instructions. Stagger couplings so those of adjacent ducts do not lie in same plane.
- E. Installation Adjacent to High-Temperature Steam Lines: Where duct banks are installed parallel to underground steam lines, perform calculations showing the duct bank will not be subject to environmental temperatures above 40 deg C. Where environmental temperatures are calculated to rise above 40 deg C, and anywhere the duct bank crosses above an underground steam line, install insulation blankets listed for direct burial to isolate the duct bank from the steam line.
- F. Duct Entrances to Manholes and Concrete and Polymer Concrete Handholes: Use end bells, spaced approximately 10 inches o.c. for 5-inch ducts, and vary proportionately for other duct sizes.
 - 1. Begin change from regular spacing to end-bell spacing 10 feet from the end bell without reducing duct line slope and without forming a trap in the line.
 - 2. Direct-Buried Duct Banks: Install an expansion and deflection fitting in each conduit in the area of disturbed earth adjacent to manhole or handhole. Install an

- expansion fitting near the center of all straight line direct-buried duct banks with calculated expansion of more than 3/4 inch.
3. Grout end bells into structure walls from both sides to provide watertight entrances.
- G. Building Wall Penetrations: Make a transition from underground duct to rigid steel conduit at least 10 feet outside the building wall, without reducing duct line slope away from the building, and without forming a trap in the line. Use fittings manufactured for duct-to-conduit transition. Install conduit penetrations of building walls as specified in Section 16051 "Sleeves and Sleeve Seals for Electrical Raceways and Cabling."
- H. Sealing: Provide temporary closure at terminations of ducts that have cables pulled. Seal spare ducts at terminations. Use sealing compound and plugs to withstand at least 15-psi hydrostatic pressure.
- I. Pulling Cord: Install 100-lbf-test nylon cord in empty ducts.
- J. Concrete-Encased Ducts: Support ducts on duct separators.
1. Excavate trench bottom to provide firm and uniform support for duct bank. Prepare trench bottoms as specified in the Civil specifications for pipes less than 6 inches in nominal diameter.
 2. Depth: Install top of duct bank at least 24 inches below finished grade in areas not subject to deliberate traffic, and at least 30 inches below finished grade in deliberate traffic paths for vehicles unless otherwise indicated.
 3. Support ducts on duct separators coordinated with duct size, duct spacing, and outdoor temperature.
 4. Separator Installation: Space separators close enough to prevent sagging and deforming of ducts, with not less than four spacers per 20 feet of duct. Secure separators to earth and to ducts to prevent floating during concreting. Stagger separators approximately 6 inches between tiers. Tie entire assembly together using fabric straps; do not use tie wires or reinforcing steel that may form conductive or magnetic loops around ducts or duct groups.
 5. Minimum Space between Ducts: 3 inches between ducts and exterior envelope wall, 2 inches between ducts for like services, and 4 inches between power and signal ducts.
 6. Elbows: Use manufactured rigid steel conduit elbows for stub-ups at poles and equipment, at building entrances through floor, and at changes of direction in duct run.
 - a. Couple steel conduits to ducts with adapters designed for this purpose, and encase coupling with 3 inches of concrete.
 - b. Stub-Ups to Equipment: For equipment mounted on outdoor concrete bases, extend steel conduit horizontally a minimum of 60 inches from edge of base. Install insulated grounding bushings on terminations at equipment.
 7. Reinforcement: Reinforce concrete-encased duct banks where they cross disturbed earth and where indicated. Arrange reinforcing rods and ties without forming conductive or magnetic loops around ducts or duct groups.

8. Forms: Use walls of trench to form side walls of duct bank where soil is self-supporting and concrete envelope can be poured without soil inclusions; otherwise, use forms.
9. Concrete Cover: Install a minimum of 3 inches of concrete cover at top and bottom, and a minimum of 2 inches on each side of duct bank.
10. Pouring Concrete: Comply with requirements in "Concrete Placement" Article in Section 03300 "Cast-in-Place Concrete." Place concrete carefully during pours to prevent voids under and between conduits and at exterior surface of envelope. Do not allow a heavy mass of concrete to fall directly onto ducts. Allow concrete to flow to center of bank and rise up in middle, uniformly filling all open spaces. Do not use power-driven agitating equipment unless specifically designed for duct-bank application.

K. Direct-Buried Duct Banks:

1. Excavate trench bottom to provide firm and uniform support for duct bank. Comply with requirements in the Civil specifications for preparation of trench bottoms for pipes less than 6 inches in nominal diameter.
2. Support ducts on duct separators coordinated with duct size, duct spacing, and outdoor temperature.
3. Space separators close enough to prevent sagging and deforming of ducts, with not less than four spacers per 20 feet of duct. Secure separators to earth and to ducts to prevent displacement during backfill and yet permit linear duct movement due to expansion and contraction as temperature changes. Stagger spacers approximately 6 inches between tiers.
4. Depth: Install top of duct bank at least 36 inches below finished grade unless otherwise indicated.
5. Set elevation of bottom of duct bank below frost line.
6. Install ducts with a minimum of 3 inches between ducts for like services and 6 inches between power and signal ducts.
7. Install manufactured rigid steel conduit elbows for stub-ups at poles and equipment, at building entrances through floor, and at changes of direction in duct run.
 - a. Couple steel conduits to ducts with adapters designed for this purpose, and encase coupling with 3 inches of concrete.
 - b. For equipment mounted on outdoor concrete bases, extend steel conduit horizontally a minimum of 60 inches from edge of equipment pad or foundation. Install insulated grounding bushings on terminations at equipment.
8. After installing first tier of ducts, backfill and compact. Start at tie-in point and work toward end of duct run, leaving ducts at end of run free to move with expansion and contraction as temperature changes during this process. Repeat procedure after placing each tier. After placing last tier, hand place backfill to 4 inches over ducts and hand tamp. Firmly tamp backfill around ducts to provide maximum supporting strength. Use hand tamper only. After placing controlled backfill over final tier, make final duct connections at end of run and complete backfilling with normal compaction. Comply with requirements in the Civil specifications for installation of backfill materials.

- a. Place minimum 3 inches of sand as a bed for duct bank. Place sand to a minimum of 6 inches above top level of duct bank.
- L. Warning Tape: Bury warning tape approximately 12 inches above all concrete-encased ducts and duct banks. Align tape parallel to and within 3 inches of centerline of duct bank. Provide an additional warning tape for each 12-inch increment of duct-bank width over a nominal 18 inches. Space additional tapes 12 inches apart, horizontally.

3.4 GROUNDING

- A. Ground underground ducts and utility structures according to Section 16450 "Grounding and Bonding for Electrical Systems."

3.5 FIELD QUALITY CONTROL

- A. Perform the following tests and inspections and prepare test reports:
 - 1. Demonstrate capability and compliance with requirements on completion of installation of underground ducts and utility structures.
 - 2. Pull solid aluminum or wood test mandrel through duct to prove joint integrity and adequate bend radii, and test for out-of-round duct. Provide a minimum 6-inch-long mandrel equal to 80 percent fill of duct. If obstructions are indicated, remove obstructions and retest.
- B. Correct deficiencies and retest as specified above to demonstrate compliance.

3.6 CLEANING

- A. Pull leather-washer-type duct cleaner, with graduated washer sizes, through full length of ducts. Follow with rubber duct swab for final cleaning and to assist in spreading lubricant throughout ducts.
- B. Clean internal surfaces of manholes, including sump. Remove foreign material.

END OF SECTION

SECTION 16120

LOW-VOLTAGE ELECTRICAL POWER CONDUCTORS AND CABLES

PART 1 - GENERAL

1.1 SUMMARY

A. Section Includes:

1. Building wires and cables rated 2000 V and less.
2. Connectors, splices, and terminations rated 2000 V and less.

B. Related Requirements:

1. Section 16800 "Telecommunications Cabling" for cabling used for voice and data circuits.

1.2 ACTION SUBMITTALS

A. Product Data: For each type of product.

B. Product Schedule: Indicate type, use, location, and termination locations.

1.3 INFORMATIONAL SUBMITTALS

A. Qualification Data: For manufacturer's authorized service representative.

B. Field quality-control reports.

PART 2 - PRODUCTS

2.1 CONDUCTORS AND CABLES

A. Electrical Components, Devices, and Accessories: Listed and labeled as defined in NFPA 70, by a qualified testing agency, and marked for intended location and application.

B. Conductor and Cable Marking: Comply with wire and cable marking according to UL's "Wire and Cable Marking and Application Guide."

C. Comply with UL 1277, UL 1685, and NFPA 70 for Type TC-ER cable used in VFC circuits.

D. Conductors: Copper, complying with NEMA WC 70/ICEA S-95-658.

1. Conductor Insulation: Comply with NEMA WC 70/ICEA S-95-658 for Type THHN/THWN-2 and Type XHHW-2.

- E. Cable: Comply with NEMA WC 70/ICEA S-95-658 for metal-clad cable, Type MC with ground wire.

2.2 CONNECTORS AND SPLICES

- A. Description: Factory-fabricated connectors and splices of size, ampacity rating, material, type, and class for application and service indicated; listed and labeled as defined in NFPA 70, by a qualified testing agency, and marked for intended location and application.

PART 3 - EXECUTION

3.1 CONDUCTOR MATERIAL APPLICATIONS

- A. Feeders: Copper; solid or stranded for No. 10 AWG and smaller; stranded for No. 8 AWG and larger.
- B. Branch Circuits: Copper. Solid or stranded for No. 10 AWG and smaller; stranded for No. 8 AWG and larger.

3.2 CONDUCTOR INSULATION AND MULTICONDUCTOR CABLE APPLICATIONS AND WIRING METHODS

- A. Service Entrance: Type XHHW-2, single conductors in raceway.
- B. Exposed Feeders: Type XHHW-2, single conductors in raceway.
- C. Feeders Concealed in Ceilings, Walls, Partitions, and Crawlspace: Type THHN/THWN-2, single conductors in raceway.
- D. Feeders Concealed in Concrete, below Slabs-on-Grade, and Underground: Type THHN/THWN-2, single conductors in raceway and Type XHHW-2, single conductors in raceway.
- E. Exposed Branch Circuits, Including in Crawlspace: Type THHN/THWN-2, single conductors in raceway and Metal-clad cable, Type MC.
- F. Branch Circuits Concealed in Ceilings, Walls, and Partitions: Type THHN/THWN-2, single conductors in raceway and Metal-clad cable, Type MC.
- G. Branch Circuits Concealed in Concrete, below Slabs-on-Grade, and Underground: Type THHN/THWN-2, single conductors in raceway.
- H. Cord Drops and Portable Appliance Connections: Type SO, hard service cord with stainless-steel, wire-mesh, strain relief device at terminations to suit application.

3.3 INSTALLATION OF CONDUCTORS AND CABLES

- A. Conceal cables in finished walls, ceilings, and floors unless otherwise indicated.
- B. Complete raceway installation between conductor and cable termination points according to Section 16110 "Raceways and Boxes for Electrical Systems" prior to pulling conductors and cables.
- C. Use manufacturer-approved pulling compound or lubricant where necessary; compound used must not deteriorate conductor or insulation. Do not exceed manufacturer's recommended maximum pulling tensions and sidewall pressure values.
- D. Use pulling means, including fish tape, cable, rope, and basket-weave wire/cable grips, that will not damage cables or raceway.
- E. Install exposed cables parallel and perpendicular to surfaces of exposed structural members, and follow surface contours where possible.
- F. Support cables according to Section 16050 "Hangers and Supports for Electrical Systems."
- G. Install sleeves and sleeve seals at penetrations of exterior floor and wall assemblies. Comply with requirements in Section 16051 "Sleeves and Sleeve Seals for Electrical Raceways and Cabling."
- H. Apply firestopping to electrical penetrations of fire-rated floor and wall assemblies to restore original fire-resistance rating of assembly according to Section 07841 "Penetration Firestopping."

3.4 CONNECTIONS

- A. Tighten electrical connectors and terminals according to manufacturer's published torque-tightening values. If manufacturer's torque values are not indicated, use those specified in UL 486A-486B.
- B. Make splices, terminations, and taps that are compatible with conductor material and that possess equivalent or better mechanical strength and insulation ratings than unspliced conductors.
 - 1. Use oxide inhibitor in each splice, termination, and tap for aluminum conductors.
- C. Wiring at Outlets: Install conductor at each outlet, with at least 6 inches of slack.

3.5 IDENTIFICATION

- A. Identify and color-code conductors and cables according to Section 16052 "Identification for Electrical Systems."

- B. Identify each spare conductor at each end with identity number and location of other end of conductor, and identify as spare conductor.

3.6 SLEEVE AND SLEEVE-SEAL INSTALLATION FOR ELECTRICAL PENETRATIONS

- A. Install sleeves and sleeve seals at penetrations of exterior floor and wall assemblies. Comply with requirements in Section 16051 "Sleeves and Sleeve Seals for Electrical Raceways and Cabling."

3.7 FIRESTOPPING

- A. Apply firestopping to electrical penetrations of fire-rated floor and wall assemblies to restore original fire-resistance rating of assembly according to Section 07841 "Penetration Firestopping."

3.8 FIELD QUALITY CONTROL

- A. Perform the following tests and inspections with the assistance of a factory-authorized service representative:

1. After installing conductors and cables and before electrical circuitry has been energized, test service entrance and feeder conductors and conductors feeding critical equipment and services for compliance with requirements.
2. Perform each of the following visual and electrical tests:
 - a. Compare conductor and cable data with Drawings and Specifications.
 - b. Inspect exposed sections of conductor and cable for physical damage and correct connection according to the single-line diagram.
 - c. Test bolted connections for high resistance using one of the following:
 - 1) A low-resistance ohmmeter.
 - 2) Calibrated torque wrench.
 - 3) Thermographic survey.
 - d. Inspect compression applied connectors for correct cable match and indentation.
 - e. Inspect for correct identification.
 - f. Inspect cable jacket and condition.
 - g. Perform insulation-resistance test on each conductor with respect to ground and adjacent conductors. Apply a potential of 500-V dc for 300-V rated cable and 1000-V dc for 600-V rated cable for a one-minute duration.
 - h. Continuity test on each conductor and cable.
 - i. Uniform resistance of parallel conductors.

- B. Cables will be considered defective if they do not pass tests and inspections.

- C. Prepare Test and Inspection Reports: Prepare a written report to record the following:
1. Procedures used.
 2. Results that comply with requirements.
 3. Results that do not comply with requirements and corrective action taken to achieve compliance with requirements.

END OF SECTION

SECTION 16130

WIRING DEVICES

PART 1 - GENERAL

1.1 SUMMARY

A. Section Includes:

1. Straight-blade convenience and specialty receptacles.
2. GFCI receptacles.
3. Toggle switches.
4. Wall switch sensor light switches with dual technology sensors.
5. Wall switch sensor light switches with passive infrared sensors.
6. Wall switch sensor light switches with ultrasonic sensors.
7. Wall-box dimmers.
8. Wall plates.

1.2 DEFINITIONS

A. Abbreviations of Manufacturers' Names:

1. Cooper: Copper Wiring Devices; Division of Cooper Industries, Inc.
2. Hubbell: Hubbell Incorporated: Wiring Devices-Kellems.
3. Leviton: Leviton Mfg. Company, Inc.
4. Pass & Seymour: Pass& Seymour/Legrand.

1.3 ACTION SUBMITTALS

- A. Product Data: For each type of product.
- B. Shop Drawings: List of legends and description of materials and process used for premarking wall plates.

1.4 CLOSEOUT SUBMITTALS

- A. Operation and maintenance data.

PART 2 - PRODUCTS

2.1 GENERAL WIRING-DEVICE REQUIREMENTS

- A. Wiring Devices, Components, and Accessories: Listed and labeled as defined in NFPA 70, by a qualified testing agency, and marked for intended location and application.

- B. Comply with NFPA 70.
- C. Devices that are manufactured for use with modular plug-in connectors may be substituted under the following conditions:
 - 1. Connectors shall comply with UL 2459 and shall be made with stranding building wire.
 - 2. Devices shall comply with the requirements in this Section.
- D. Devices for Owner-Furnished Equipment:
 - 1. Receptacles: Match plug configurations.
- E. Source Limitations: Obtain each type of wiring device and associated wall plate from single source from single manufacturer.

2.2 STRAIGHT-BLADE RECEPTACLES

- A. Duplex and Quadruplex Convenience Receptacles, 125 V, 20 A: Comply with NEMA WD 1, NEMA WD 6 Configuration 5-20R, UL 498, and FS W-C-596.
- B. Specialty receptacles as indicated on the drawings: Comply with all applicable NEMA, UL, and FS standards.

2.3 GFCI RECEPTACLES

- A. General Description:
 - 1. 125 V, 20 A, straight blade, feed-through type.
 - 2. Comply with NEMA WD 1, NEMA WD 6 Configuration 5-20R, UL 498, UL 943 Class A, and FS W-C-596.
 - 3. Include indicator light that shows when the GFCI has malfunctioned and no longer provides proper GFCI protection.

2.4 TOGGLE SWITCHES

- A. Comply with NEMA WD 1, UL 20, and FS W-S-896.
- B. Switches, 120/277 V, 20 A:
 - 1. Single Pole
 - 2. Two Pole
 - 3. Three Way
 - 4. Four Way
- C. Pilot-Light Switches, 120/277 V, 20 A:

1. Description: Single pole, with LED-lighted handle, illuminated when switch is off.
- D. Key-Operated Switches, 120/277 V, 20 A:
1. Description: Single pole, with factory-supplied key in lieu of switch handle.
- E. Single-Pole, Double-Throw, Momentary-Contact, Center-off Switches: 120/277 V, 20 A; for use with mechanically held lighting contactors.
- F. Key-Operated, Single-Pole, Double-Throw, Momentary-Contact, Center-off Switches: 120/277 V, 20 A; for use with mechanically held lighting contactors, with factory-supplied key in lieu of switch handle.

2.5 WALL SWITCH SENSOR LIGHT SWITCH, PASSIVE INFRARED

- A. Description: Switchbox-mounted, combination, lighting-control sensor and conventional switch lighting-control unit using passive infrared technology.
1. Connections: Provisions for connection to BAS.
 2. Connections: Hard wired.
 3. Connections: Wireless.
 4. Rated 960 W at 120-V ac for tungsten lighting, 10 A at 120-V ac or 10 A at 277-V ac for fluorescent or LED lighting, and 1/4 hp at 120-V ac.
 5. Integral relay for connection to BAS.
 6. Adjustable time delay of five minutes.
 7. Able to be locked to Automatic-On and manual mode.
 8. Automatic Light-Level Sensor: Adjustable from 2 to 200 fc.
 9. Comply with NEMA WD 1, UL 20, and FS W-S-896.

2.6 WALL SWITCH SENSOR LIGHT SWITCH, ULTRASONIC

- A. Description: Switchbox-mounted, combination, lighting-control sensor and conventional switch lighting-control unit using ultrasonic technology.
1. Connections: Provisions for connection to BAS.
 2. Connections: Hard wired.
 3. Connections: Wireless.
 4. Rated 960 W at 120-V ac for tungsten lighting, 10 A at 120-V ac or 10 A at 277-V ac for fluorescent or LED lighting, and 1/4 hp at 120-V ac.
 5. Integral relay for connection to BAS.
 6. Adjustable time delay of five minutes.
 7. Able to be locked to Automatic-On and Manual-On mode.
 8. Automatic Light-Level Sensor: Adjustable from 2 to 200 fc.
 9. Comply with NEMA WD 1, UL 20, and FS W-S-896.

2.7 WALL-BOX DIMMERS

- A. Dimmer Switches: Modular, full-wave, solid-state units with integral, quiet on-off switches, with audible frequency and EMI/RFI suppression filters.
- B. Control: Continuously adjustable slider; with single-pole or three-way switching. Comply with UL 1472.
- C. Incandescent Lamp Dimmers: 120 V; control shall follow square-law dimming curve. On-off switch positions shall bypass dimmer module.
 - 1. 600 W; dimmers shall require no derating when ganged with other devices. Illuminated when "off."
- D. Fluorescent Lamp Dimmer Switches: Modular; compatible with dimmer ballasts; trim potentiometer to adjust low-end dimming; dimmer-ballast combination capable of consistent dimming with low end not greater than 20 percent of full brightness.
- E. LED Lamp Dimmer Switches: Modular; compatible with LED lamps; trim potentiometer to adjust low-end dimming; capable of consistent dimming with low end not greater than 20 percent of full brightness.

2.8 WALL PLATES

- A. Single and combination types shall match corresponding wiring devices.
 - 1. Plate-Securing Screws: Metal with head color to match plate finish.
 - 2. Material for Finished Spaces: 0.035-inch-thick, satin-finished, Type 302 stainless steel.
 - 3. Material for Unfinished Spaces: Galvanized steel.
 - 4. Material for Damp Locations: Thermoplastic with spring-loaded lift cover, and listed and labeled for use in wet and damp locations.
- B. Wet-Location, Weatherproof Cover Plates: NEMA 250, complying with Type 3R, weather-resistant, die-cast aluminum with lockable cover.

2.9 FINISHES

- A. Device Color:
 - 1. Wiring Devices Connected to Normal Power System: Gray coordinate with Architect unless otherwise indicated or required by NFPA 70 or device listing.
 - 2. Wiring Devices Connected to Emergency Power System: Red.
 - 3. SPD Devices: Blue.
- B. Wall Plate Color: For plastic covers, match device color.

PART 3 - EXECUTION

3.1 INSTALLATION

- A. Comply with NECA 1, including mounting heights listed in that standard, unless otherwise indicated.
- B. Coordination with Other Trades:
 - 1. Protect installed devices and their boxes. Do not place wall finish materials over device boxes and do not cut holes for boxes with routers that are guided by riding against outside of boxes.
 - 2. Keep outlet boxes free of plaster, drywall joint compound, mortar, cement, concrete, dust, paint, and other material that may contaminate the raceway system, conductors, and cables.
 - 3. Install device boxes in brick or block walls so that the cover plate does not cross a joint unless the joint is troweled flush with the face of the wall.
 - 4. Install wiring devices after all wall preparation, including painting, is complete.
- C. Conductors:
 - 1. Do not strip insulation from conductors until right before they are spliced or terminated on devices.
 - 2. Strip insulation evenly around the conductor using tools designed for the purpose. Avoid scoring or nicking of solid wire or cutting strands from stranded wire.
 - 3. The length of free conductors at outlets for devices shall meet provisions of NFPA 70, Article 300, without pigtails.
 - 4. Existing Conductors:
 - a. Cut back and pigtail, or replace all damaged conductors.
 - b. Straighten conductors that remain and remove corrosion and foreign matter.
 - c. Pigtailing existing conductors is permitted, provided the outlet box is large enough.
- D. Device Installation:
 - 1. Replace devices that have been in temporary use during construction and that were installed before building finishing operations were complete.
 - 2. Keep each wiring device in its package or otherwise protected until it is time to connect conductors.
 - 3. Do not remove surface protection, such as plastic film and smudge covers, until the last possible moment.
 - 4. Connect devices to branch circuits using pigtails that are not less than 6 inches in length.
 - 5. When there is a choice, use side wiring with binding-head screw terminals. Wrap solid conductor tightly clockwise, two-thirds to three-fourths of the way around terminal screw.
 - 6. Use a torque screwdriver when a torque is recommended or required by manufacturer.

7. When conductors larger than No. 12 AWG are installed on 15- or 20-A circuits, splice No. 12 AWG pigtails for device connections.
8. Tighten unused terminal screws on the device.
9. When mounting into metal boxes, remove the fiber or plastic washers used to hold device-mounting screws in yokes, allowing metal-to-metal contact.

E. Receptacle Orientation:

1. Install ground pin of vertically mounted receptacles up, and on horizontally mounted receptacles to the right.

F. Device Plates: Do not use oversized or extra-deep plates. Repair wall finishes and remount outlet boxes when standard device plates do not fit flush or do not cover rough wall opening.

G. Dimmers:

1. Install dimmers within terms of their listing.
2. Verify that dimmers used for fan-speed control are listed for that application.
3. Install unshared neutral conductors on line and load side of dimmers according to manufacturers' device listing conditions in the written instructions.

H. Arrangement of Devices: Unless otherwise indicated, mount flush, with long dimension vertical and with grounding terminal of receptacles on top. Group adjacent switches under single, multigang wall plates.

I. GFCI Receptacles: Install non-feed-through-type GFCI receptacles where protection of downstream receptacles is not required.

3.2 FIELD QUALITY CONTROL

A. Test Instruments: Use instruments that comply with UL 1436.

B. Test Instrument for Convenience Receptacles: Digital wiring analyzer with digital readout or illuminated digital-display indicators of measurement.

C. Perform the following tests and inspections:

1. Tests for Convenience Receptacles:

- a. Line Voltage: Acceptable range is 105 to 132 V.
- b. Percent Voltage Drop under 15-A Load: A value of 6 percent or higher is unacceptable.
- c. Ground Impedance: Values of up to 2 ohms are acceptable.
- d. GFCI Trip: Test for tripping values specified in UL 1436 and UL 943.
- e. Using the test plug, verify that the device and its outlet box are securely mounted.
- f. Tests shall be diagnostic, indicating damaged conductors, high resistance at the circuit breaker, poor connections, inadequate fault current path, defective devices, or similar problems. Correct circuit conditions, remove

malfunctioning units and replace with new ones, and retest as specified above.

- D. Wiring device will be considered defective if it does not pass tests and inspections.
- E. Prepare test and inspection reports.

END OF SECTION

SECTION 16131

WIRING SPECIALTIES – HEAT TRACING

PART 1 - GENERAL

1.1 SUMMARY

A. Section Includes:

1. Plumbing heat trace.
2. Hot water piping to toll booths (underground in cased piping).

B. Related Requirements:

1. Section 16120 “Low voltage electrical Power Conductors and Cables”
2. Examine all Drawings and all Sections of the Specifications for requirements and provisions affecting the work of this Section
3. Coordinate the work required with the activities of other Contractors at the site. Cooperate with other site Contractors to assure steady progress of all work being performed in the area.

1.2 ACTION SUBMITTALS

- A. Product Data: For each type of product.
- B. Product Schedule: Indicate type, use, location, and termination locations.

1.3 INFORMATIONAL SUBMITTALS

- A. Qualification Data: For manufacturer’s authorized service representative.
- B. Field quality reports.
- C. Shop Drawings: For Heat trace wiring and controls. Include plans, and attachments to other work.

1.4 QUALITY ASSURANCE

- A. Comply with NFPA 70.

PART 2 – PRODUCTS

2.1 SELF-REGULATING, PARALLEL-RESISTANCE HEATING CABLES:

- A. Heating Element: Pair of parallel nickel-coated stranded copper bus wires embedded in cross linked conductive polymer core.
- B. Electrical Insulating Jacket: Flame-retardant polyolefin.

- C. Cable Cover: Tinned-copper or stainless-steel braid, and polyolefin outer jacket with UV inhibitor.
- D. Cable model: Chromalox SRL, or equivalent product. 10 w/ft.
- E. Systems shall be UL listed and approved by FM for this specific type of duty.
- F. Protect the heater from physical damage.
- G. Tracing used in gutters and downspouts shall be extended down the leaders to below the surface of the ground, or until the leader goes inside the insulation envelope.

2.2 CONTROLS:

- A. Chromalox (or equivalent manufacturer) - Model GF Pro Snow Switch thermostat/controller with the following features:
 - 1. 30mA Ground Fault Protection
 - 2. 120, 208, 240 277 Voltage ranges
 - 3. Temperature Sensor with NEC class 2 circuit
 - 4. 30 amps load maximum
 - 5. Power Connection Kit for use with Chromalox SRL type cable. Power connection kit shall be Chromalox (or equivalent manufacturer) part number RG-PK-1.
 - 6. One freeze protection thermostat/controller per individual heat trace circuit.
 - 7. Controller shall be capable of tying in with Building Management System.
- B. For underground hot water piping from tunnel to toll booth: provide 10 watts per foot min. capacity control to 50° F (adjustable) setpoint.

2.3 ACCESSORIES:

- A. Cable Installation Accessories: Fiberglass tape, heat-conductive putty, cable ties, silicone end seals and splice kits, and installation clips all furnished by manufacturer, or as recommended in writing by manufacturer.
- B. Warning Tape: Continuously printed "Electrical Tracing."

PART 3 - EXECUTION

3.1 INSTALLATION

- A. Install individual wall-mounted switches and circuit breakers with tops at uniform height unless otherwise indicated.
- B. Temporary Lifting Provisions: Remove temporary lifting eyes, channels, and brackets and temporary blocking of moving parts from enclosures and components.
- C. Install fuses in fusible devices.

- D. Comply with NECA 1.

3.2 IDENTIFICATION

- A. Comply with requirements in Division 16 Section "Identification for Electrical Systems."
 - 1. Identify field-installed conductors, interconnecting wiring, and components; provide warning signs.
 - 2. Label Controller/thermostat and Power connection Kit with engraved metal or laminated-plastic nameplate.

3.3 FIELD QUALITY CONTROL

- A. Perform tests and inspections.
- B. Acceptance Testing Preparation:
 - 1. Test continuity of each circuit.
- C. Tests and Inspections:
 - 1. Perform each visual and mechanical inspection and electrical test stated in NETA Acceptance Testing Specification. Certify compliance with test parameters.
 - 2. Correct malfunctioning units on-site, where possible, and retest to demonstrate compliance; otherwise, replace with new units and retest. See Division 01 Section "Quality Requirements" for retesting and re-inspection requirements and Division 01 Section "Execution" for requirements for correcting the Work.

END OF SECTION

SECTION 16287

SURGE PROTECTION FOR LOW-VOLTAGE ELECTRICAL POWER CIRCUITS

PART 1 - GENERAL

1.1 SUMMARY

- A. Section includes field-mounted SPDs for low-voltage (120 to 600 V) power distribution and control equipment.

1.2 ACTION SUBMITTALS

- A. Product Data: For each type of product.
 - 1. Include rated capacities, operating characteristics, electrical characteristics, and furnished specialties and accessories.
 - 2. Copy of UL Category Code VZCA certification, as a minimum, listing the tested values for VPRs, Inominal ratings, MCOVs, type designations, OCPD requirements, model numbers, system voltages, and modes of protection.

1.3 INFORMATIONAL SUBMITTALS

- A. Field quality-control reports.
- B. Sample Warranty: For manufacturer's special warranty.

1.4 CLOSEOUT SUBMITTALS

- A. Maintenance data.

1.5 WARRANTY

- A. Manufacturer's Warranty: Manufacturer agrees to replace or replace SPDs that fail in materials or workmanship within specified warranty period.
 - 1. Warranty Period: Five years from date of Substantial Completion.

PART 2 - PRODUCTS

2.1 GENERAL SPD REQUIREMENTS

- A. SPD with Accessories: Listed and labeled as defined in NFPA 70, by a qualified testing agency, and marked for intended location and application.

- B. Comply with NFPA 70.
- C. Comply with UL 1449.
- D. MCOV of the SPD shall be the nominal system voltage.

2.2 SERVICE ENTRANCE SUPPRESSOR

- A. SPDs: Comply with UL 1449, Type 1.
 - 1. SPDs with the following features and accessories:
 - a. Integral disconnect switch.
 - b. Internal thermal protection that disconnects the SPD before damaging internal suppressor components.
 - c. Indicator light display for protection status.
 - B. Peak Surge Current Rating: The minimum single-pulse surge current withstand rating per phase shall not be less than 200 kA. The peak surge current rating shall be the arithmetic sum of the ratings of the individual MOVs in a given mode.
 - C. Protection modes and UL 1449 VPR for grounded wye circuits with 480Y/277 V, three-phase, four-wire circuits shall not exceed the following:
 - 1. Line to Neutral: 1200 V for 480Y/277 V 700 V for 208Y/120 V.
 - 2. Line to Ground: 1200 V for 480Y/277 V 1200 V for 208Y/120 V.
 - 3. Line to Line: 2000 V for 480Y/277 V 1000 V for 208Y/120 V.
 - D. Protection modes and UL 1449 VPR for 240/120 V, single-phase, three-wire circuits shall not exceed the following:
 - 1. Line to Neutral: 700 V.
 - 2. Line to Ground: 700 V 1000 V.
 - 3. Line to Line: 1000 V.
 - E. SCCR: Equal or exceed 200 kA.
 - F. Inominal Rating: 20 kA.

2.3 PANEL SUPPRESSORS

- A. SPDs: Comply with UL 1449, Type 1.
 - 1. Include LED indicator lights for power and protection status.
 - 2. Internal thermal protection that disconnects the SPD before damaging internal suppressor components.
- B. Peak Surge Current Rating: The minimum single-pulse surge current withstand rating per phase shall not be less than 100 kA. The peak surge current rating shall be the arithmetic sum of the ratings of the individual MOVs in a given mode.

- C. Protection modes and UL 1449 VPR for grounded wye circuits with 480Y/277 V and 208Y/120 V, three-phase, four-wire circuits shall not exceed the following:
 - 1. Line to Neutral: 1200 V for 480Y/277 V, 700 V for 208Y/120 V.
 - 2. Line to Ground: 1200 V for 480Y/277 V, 700 V for 208Y/120 V.
 - 3. Neutral to Ground: 1200 V for 480Y/277V, 700 V for 208Y/120 V.
 - 4. Line to Line: 2000 V for 480Y/277 V, 1200 V for 208Y/120 V
- D. Protection modes and UL 1449 VPR for 240/120-V, single-phase, three-wire circuits shall not exceed the following:
 - 1. Line to Neutral: 700 V.
 - 2. Line to Ground: 700 V.
 - 3. Neutral to Ground: 700 V.
 - 4. Line to Line: 1200 V.
- E. SCCR: Equal or exceed 100 kA.
- F. Inominal Rating: 20 kA.

2.4 ENCLOSURES

- A. Indoor Enclosures: NEMA 250, Type 1.

PART 3 - EXECUTION

3.1 INSTALLATION

- A. Comply with NECA 1.
- B. Install an OCPD or disconnect as required to comply with the UL listing of the SPD.
- C. Install SPDs with conductors between suppressor and points of attachment as short and straight as possible, and adjust circuit-breaker positions to achieve shortest and straightest leads. Do not splice and extend SPD leads unless specifically permitted by manufacturer. Do not exceed manufacturer's recommended lead length. Do not bond neutral and ground.
- D. Use crimped connectors and splices only. Wire nuts are unacceptable.
- E. Complete startup checks according to manufacturer's written instructions. Energize SPDs after power system has been energized, stabilized, and tested.

3.2 FIELD QUALITY CONTROL

- A. Perform the following tests and inspections with the assistance of a factory-authorized service representative.

1. Compare equipment nameplate data for compliance with Drawings and Specifications.
 2. Inspect anchorage, alignment, grounding, and clearances.
 3. Verify that electrical wiring installation complies with manufacturer's written installation requirements.
- B. An SPD will be considered defective if it does not pass tests and inspections.
- C. Prepare test and inspection reports.

END OF SECTION

SECTION 16375

ELECTRICITY METERING

PART 1 - GENERAL

1.1 SUMMARY

- A. Section includes equipment for electricity metering by utility company and electricity metering by Owner.

1.2 ACTION SUBMITTALS

- A. Product Data: For each type of product indicated.
- B. Shop Drawings: Dimensioned plans and sections or elevation layouts and wiring diagrams.

1.3 INFORMATIONAL SUBMITTALS

- A. Field quality-control reports.

1.4 CLOSEOUT SUBMITTALS

- A. Operation and Maintenance Data.

1.5 QUALITY ASSURANCE

- A. Electrical Components, Devices, and Accessories: Listed and labeled as defined in NFPA 70, by a qualified testing agency, and marked for intended location and application.

PART 2 - PRODUCTS

2.1 EQUIPMENT FOR ELECTRICITY METERING BY UTILITY COMPANY

- A. Meters will be furnished by utility company.
- B. Current-Transformer Cabinets: Comply with requirements of electrical-power utility company.
- C. Meter Sockets: Comply with requirements of electrical-power utility company.
- D. Meter Sockets: Steady-state and short-circuit current ratings shall meet indicated circuit ratings.

PART 3 - EXECUTION

3.1 INSTALLATION

- A. Comply with equipment installation requirements in NECA 1.
- B. Install meters furnished by utility company. Install raceways and equipment according to utility company's written requirements. Provide empty conduits for metering leads and extend grounding connections as required by utility company.
- C. Install modular meter center according to NECA 400 switchboard installation requirements.
- D. Comply with requirements for identification specified in Section 16052 "Identification for Electrical Systems."
 - 1. Series Combination Warning Label: Self-adhesive type, with text as required by NFPA 70.
 - 2. Equipment Identification Labels: Adhesive film labels with clear protective overlay. For residential meters, provide an additional card holder suitable for printed, weather-resistant card with occupant's name.

3.2 FIELD QUALITY CONTROL

- A. Perform tests and inspections.
- B. Tests and Inspections:
 - 1. Connect a load of known kilowatt rating, 1.5kW minimum, to a circuit supplied by metered feeder.
 - 2. Turn off circuits supplied by metered feeder and secure them in off condition.
 - 3. Run test load continuously for eight hours minimum, or longer, to obtain a measurable meter indication. Use test-load placement and setting that ensures continuous, safe operation.
 - 4. Check and record meter reading at end of test period and compare with actual electricity used, based on test-load rating, duration of test, and sample measurements of supply voltage at test-load connection. Record test results.
- C. Electricity metering will be considered defective if it does not pass tests and inspections.
- D. Prepare test and inspection reports.

END OF SECTION

SECTION 16410

TRANSFER SWITCHES

PART 1 - GENERAL

1.1 SUMMARY

- A. Section includes automatic transfer switches rated 600 V and less.

1.2 ACTION SUBMITTALS

- A. Product Data: For each type of product.
- B. Shop Drawings:
 - 1. Include plans, elevations, sections, details showing minimum clearances, conductor entry provisions, gutter space, and installed features and devices.
 - 2. Single-Line Diagram: Show connections between transfer switch, power sources, and load.

1.3 INFORMATIONAL SUBMITTALS

- A. Seismic Qualification Certificates: For transfer switches, accessories, and components, from manufacturer.
- B. Source quality control reports.
- C. Field quality-control reports.

1.4 CLOSEOUT SUBMITTALS

- A. Operation and maintenance data.

1.5 WARRANTY

- A. Manufacturer's Warranty: Manufacturer agrees to repair or replace components of transfer switch or transfer switch components that fail in materials or workmanship within specified warranty period.
 - 1. Warranty Period: 12 months from date of Substantial Completion.

PART 2 - PRODUCTS

2.1 PERFORMANCE REQUIREMENTS

- A. Electrical Components, Devices, and Accessories: Listed and labeled as defined in NFPA 70, by a qualified testing agency, and marked for intended location and application.
- B. Comply with NEMA ICS 1.
- C. Comply with NFPA 99.
- D. Comply with NFPA 110.
- E. Comply with UL 1008 unless requirements of these Specifications are stricter.
- F. Indicated Current Ratings: Apply as defined in UL 1008 for continuous loading and total system transfer, including tungsten filament lamp loads not exceeding 30 percent of switch ampere rating, unless otherwise indicated.
- G. Tested Fault-Current Closing and Short-Circuit Ratings: Adequate for duty imposed by protective devices at installation locations in Project under the fault conditions indicated, based on testing according to UL 1008.
 - 1. Where transfer switch includes internal fault-current protection, rating of switch and trip unit combination shall exceed indicated fault-current value at installation location.
 - 2. Short-time withstand capability for three cycles.
- H. Repetitive Accuracy of Solid-State Controls: All settings shall be plus or minus 2 percent or better over an operating temperature range of minus 20 to plus 70 deg C.
- I. Resistance to Damage by Voltage Transients: Components shall meet or exceed voltage-surge withstand capability requirements when tested according to IEEE C62.62. Components shall meet or exceed voltage-impulse withstand test of NEMA ICS 1.
- J. Electrical Operation: Accomplish by a nonfused, momentarily energized solenoid or electric-motor-operated mechanism. Switches for emergency or standby purposes shall be mechanically and electrically interlocked in both directions to prevent simultaneous connection to both power sources unless closed transition.

2.2 CONTACTOR-TYPE AUTOMATIC TRANSFER SWITCHES

- A. Comply with Level 1 equipment according to NFPA 110.
- B. Switch Characteristics: Designed for continuous-duty repetitive transfer of full-rated current between active power sources.

1. Limitation: Switches using molded-case switches or circuit breakers or insulated-case circuit-breaker components are unacceptable.
 2. Switch Action: Double throw; mechanically held in both directions.
 3. Contacts: Silver composition or silver alloy for load-current switching. Contactor-style automatic transfer-switch units, rated 600 A and higher, shall have separate arcing contacts.
 4. Conductor Connectors: Suitable for use with conductor material and sizes.
 5. Material: Hard-drawn copper, 98 percent conductivity.
 6. Main and Neutral Lugs: Mechanical type.
 7. Ground Lugs and Bus-Configured Terminators: Mechanical type.
 8. Ground bar.
 9. Connectors shall be marked for conductor size and type according to UL 1008.
- C. Automatic Open-Transition Transfer Switches: Interlocked to prevent the load from being closed on both sources at the same time.
1. Sources shall be mechanically and electrically interlocked to prevent closing both sources on the load at the same time.
- D. Signal-Before-Transfer Contacts: A set of normally open/normally closed dry contacts operates in advance of retransfer to normal source. Interval shall be adjustable from 1 to 30 seconds.
- E. Automatic Transfer-Switch Controller Features:
1. Controller operates through a period of loss of control power.
 2. Undervoltage Sensing for Each Phase of Normal and Alternate Source: Sense low phase-to-ground voltage on each phase. Pickup voltage shall be adjustable from 85 to 100 percent of nominal, and dropout voltage shall be adjustable from 75 to 98 percent of pickup value. Factory set for pickup at 90 percent and dropout at 85 percent.
 3. Voltage/Frequency Lockout Relay: Prevent premature transfer to generator. Pickup voltage shall be adjustable from 85 to 100 percent of nominal. Factory set for pickup at 90 percent. Pickup frequency shall be adjustable from 90 to 100 percent of nominal. Factory set for pickup at 95 percent.
 4. Time Delay for Retransfer to Normal Source: Adjustable from zero to 30 minutes, and factory set for 10 minutes. Override shall automatically defeat delay on loss of voltage or sustained undervoltage of emergency source, provided normal supply has been restored.
 5. Test Switch: Simulate normal-source failure.
 6. Switch-Position Pilot Lights: Indicate source to which load is connected.
 7. Source-Available Indicating Lights: Supervise sources via transfer-switch normal- and emergency-source sensing circuits.
 - a. Normal Power Supervision: Green light with nameplate engraved "Normal Source Available."
 - b. Emergency Power Supervision: Red light with nameplate engraved "Emergency Source Available."

8. Unassigned Auxiliary Contacts: Two normally open, single-pole, double-throw contacts for each switch position, rated 10 A at 240-V ac.
9. Transfer Override Switch: Overrides automatic retransfer control so transfer switch will remain connected to emergency power source regardless of condition of normal source. Pilot light indicates override status.
10. Engine Starting Contacts: One isolated and normally closed, and one isolated and normally open; rated 10 A at 32-V dc minimum.
11. Engine Shutdown Contacts: Instantaneous; shall initiate shutdown sequence at remote engine-generator controls after retransfer of load to normal source.
12. Engine Shutdown Contacts: Time delay adjustable from zero to five minutes, and factory set for five minutes. Contacts shall initiate shutdown at remote engine-generator controls after retransfer of load to normal source.
13. Engine-Generator Exerciser: Solid-state, programmable-time switch starts engine generator and transfers load to it from normal source for a preset time, then retransfers and shuts down engine after a preset cool-down period. Initiates exercise cycle at preset intervals adjustable from 7 to 30 days. Running periods shall be adjustable from 10 to 30 minutes. Factory settings shall be for 7-day exercise cycle, 20-minute running period, and 5-minute cool-down period. Exerciser features include the following:
 - a. Exerciser Transfer Selector Switch: Permits selection of exercise with and without load transfer.
 - b. Push-button programming control with digital display of settings.
 - c. Integral battery operation of time switch when normal control power is unavailable.

F. Large-Motor-Load Power Transfer:

1. In-Phase Monitor: Factory-wired, internal relay controls transfer so contacts close only when the two sources are synchronized in phase and frequency. Relay shall compare phase relationship and frequency difference between normal and emergency sources and initiate transfer when both sources are within 15 electrical degrees, and only if transfer can be completed within 60 electrical degrees. Transfer shall be initiated only if both sources are within 2 Hz of nominal frequency and 70 percent or more of nominal voltage.
2. Motor Disconnect and Timing Relay Controls: Designated starters in loss of power scenario shall disconnect motors before transfer and reconnect them selectively at an adjustable time interval after transfer. Control connection to motor starters shall be through wiring external to automatic transfer switch. Provide adjustable time delay between 1 and 60 seconds for reconnecting individual motor loads. Provide relay contacts rated for motor-control circuit inrush and for actual seal currents to be encountered.
3. Programmed Neutral Switch Position: Switch operator with programmed neutral position arranged to provide a midpoint between the two working switch positions, with an intentional, time-controlled pause at midpoint during transfer. Adjustable pause from 0.5 to 30 seconds minimum, and factory set for 0.5 second unless otherwise indicated. Time delay occurs for both transfer directions. Disable pause unless both sources are live.

2.3 SOURCE QUALITY CONTROL

- A. Factory Tests: Test and inspect components, assembled switches, and associated equipment according to UL 1008. Ensure proper operation. Check transfer time and voltage, frequency, and time-delay settings for compliance with specified requirements. Perform dielectric strength test complying with NEMA ICS 1.
- B. Prepare test and inspection reports.
 - 1. For each of the tests required by UL 1008, performed on representative devices, for emergency systems. Include results of test for the following conditions:
 - a. Overvoltage.
 - b. Undervoltage.
 - c. Loss of supply voltage.
 - d. Reduction of supply voltage.
 - e. Alternative supply voltage or frequency is at minimum acceptable values.
 - f. Temperature rise.
 - g. Dielectric voltage-withstand; before and after short-circuit test.
 - h. Overload.
 - i. Contact opening.
 - j. Endurance.
 - k. Short circuit.
 - l. Short-time current capability.
 - m. Receptacle withstand capability.
 - n. Insulating base and supports damage.

PART 3 - EXECUTION

3.1 INSTALLATION

- A. Floor-Mounting Switch: Anchor to floor by bolting.
 - 1. Install transfer switches on cast-in-place concrete equipment base(s). Comply with requirements for equipment bases and foundations specified in Section 03300 "Cast-in-Place Concrete."
 - 2. Coordinate size and location of concrete bases. Cast anchor-bolt inserts into bases.
 - 3. Provide workspace and clearances required by NFPA 70.
- B. Annunciator and Control Panel Mounting: Flush in wall unless otherwise indicated.
- C. Identify components according to Section 16052 "Identification for Electrical Systems."
- D. Set field-adjustable intervals and delays, relays, and engine exerciser clock.
- E. Comply with NECA 1.

3.2 CONNECTIONS

- A. Wiring to Remote Components: Match type and number of cables and conductors to generator sets, motor controls, control, and communication requirements of transfer switches as recommended by manufacturer. Increase raceway sizes at no additional cost to Owner if necessary to accommodate required wiring.
- B. Wiring Method: Install cables in raceways and cable trays except within electrical enclosures. Conceal raceway and cables except in unfinished spaces.
 - 1. Comply with requirements for raceways and boxes specified in Section 16110 "Raceways and Boxes for Electrical Systems."
- C. Wiring within Enclosures: Bundle, lace, and train conductors to terminal points with no excess and without exceeding manufacturer's limitations on bending radii.
- D. Ground equipment according to Section 16540 "Grounding and Bonding for Electrical Systems."
- E. Connect wiring according to Section 16120 "Low-Voltage Electrical Power Conductors and Cables" and Section 16800 "Telecommunications Cabling."
- F. Route and brace conductors according to manufacturer's written instructions and Section 16050 "Hangers and Supports for Electrical Systems." Do not obscure manufacturer's markings and labels.
- G. Final connections to equipment shall be made with liquidtight, flexible metallic conduit no more than 18 inches in length.

3.3 FIELD QUALITY CONTROL

- A. Perform the following tests and inspections with the assistance of a factory-authorized service representative:
 - 1. Visual and Mechanical Inspection:
 - a. Compare equipment nameplate data with Drawings and Specifications.
 - b. Inspect physical and mechanical condition.
 - c. Inspect anchorage, alignment, grounding, and required clearances.
 - d. Verify that the unit is clean.
 - e. Verify appropriate lubrication on moving current-carrying parts and on moving and sliding surfaces.
 - f. Verify that manual transfer warnings are attached and visible.
 - g. Verify tightness of all control connections.
 - h. Inspect bolted electrical connections for high resistance using one of the following methods, or both:
 - 1) Use of low-resistance ohmmeter.

- 2) Verify tightness of accessible bolted electrical connections by calibrated torque-wrench method according to manufacturer's published data.
 - i. Perform manual transfer operation.
 - j. Verify positive mechanical interlocking between normal and alternate sources.
 - k. Perform visual and mechanical inspection of surge arresters.
 - l. Inspect control power transformers.
 - 1) Inspect for physical damage, cracked insulation, broken leads, tightness of connections, defective wiring, and overall general condition.
 - 2) Verify that primary and secondary fuse or circuit-breaker ratings match Drawings.
 - 3) Verify correct functioning of drawout disconnecting contacts, grounding contacts, and interlocks.
2. Electrical Tests:
- a. Perform insulation-resistance tests on all control wiring with respect to ground.
 - b. Perform a contact/pole-resistance test. Compare measured values with manufacturer's acceptable values.
 - c. Verify settings and operation of control devices.
 - d. Calibrate and set all relays and timers.
 - e. Verify phase rotation, phasing, and synchronized operation.
 - f. Perform automatic transfer tests.
 - g. Verify correct operation and timing of the following functions:
 - 1) Normal source voltage-sensing and frequency-sensing relays.
 - 2) Engine start sequence.
 - 3) Time delay on transfer.
 - 4) Alternative source voltage-sensing and frequency-sensing relays.
 - 5) Automatic transfer operation.
 - 6) Interlocks and limit switch function.
 - 7) Time delay and retransfer on normal power restoration.
 - 8) Engine cool-down and shutdown feature.
3. Measure insulation resistance phase-to-phase and phase-to-ground with insulation-resistance tester. Include external annunciation and control circuits. Use test voltages and procedure recommended by manufacturer. Comply with manufacturer's specified minimum resistance.
- a. Check for electrical continuity of circuits and for short circuits.
 - b. Inspect for physical damage, proper installation and connection, and integrity of barriers, covers, and safety features.
 - c. Verify that manual transfer warnings are properly placed.
 - d. Perform manual transfer operation.

4. After energizing circuits, perform each electrical test for transfer switches stated in NETA ATS and demonstrate interlocking sequence and operational function for each switch at least three times.
 - a. Simulate power failures of normal source to automatic transfer switches and retransfer from emergency source with normal source available.
 - b. Simulate loss of phase-to-ground voltage for each phase of normal source.
 - c. Verify time-delay settings.
 - d. Verify pickup and dropout voltages by data readout or inspection of control settings.
 - e. Perform contact-resistance test across main contacts and correct values exceeding 500 microhms and values for one pole deviating by more than 50 percent from other poles.
 - f. Verify proper sequence and correct timing of automatic engine starting, transfer time delay, retransfer time delay on restoration of normal power, and engine cool-down and shutdown.
5. Ground-Fault Tests: Coordinate with testing of ground-fault protective devices for power delivery from both sources.
 - a. Verify grounding connections and locations and ratings of sensors.

B. Coordinate tests with tests of generator and run them concurrently.

C. Report results of tests and inspections in writing. Record adjustable relay settings and measured insulation and contact resistances and time delays. Attach a label or tag to each tested component indicating satisfactory completion of tests.

D. Transfer switches will be considered defective if they do not pass tests and inspections.

E. Remove and replace malfunctioning units and retest as specified above.

F. Prepare test and inspection reports.

G. Infrared Scanning: After Substantial Completion, but not more than 60 days after Final Acceptance, perform an infrared scan of each switch. Remove all access panels so joints and connections are accessible to portable scanner.

1. Instrument: Use an infrared scanning device designed to measure temperature or to detect significant deviations from normal values. Provide calibration record for device.
2. Record of Infrared Scanning: Prepare a certified report that identifies switches checked and that describes scanning results. Include notation of deficiencies detected, remedial action taken, and observations after remedial action.
3. Follow-up Infrared Scanning: Perform an additional follow-up infrared scan of each switch 11 months after date of Substantial Completion.

3.4 DEMONSTRATION

- A. Engage a factory-authorized service representative to train Owner's maintenance personnel to adjust, operate, and maintain transfer switches and related equipment.

- B. Training shall include testing ground-fault protective devices and instructions to determine when the ground-fault system shall be retested. Include instructions on where ground-fault sensors are located and how to avoid negating the ground-fault protection scheme during testing and circuit modifications.
- C. Coordinate this training with that for generator equipment.

END OF SECTION

SECTION 16450

GROUNDING AND BONDING FOR ELECTRICAL SYSTEMS

PART 1 - GENERAL

1.1 SUMMARY

- A. Section includes grounding and bonding systems and equipment.
- B. Section includes grounding and bonding systems and equipment, plus the following special applications:
 - 1. Underground distribution grounding.
 - 2. Ground bonding common with lightning protection system.
 - 3. Foundation steel electrodes.

1.2 ACTION SUBMITTALS

- A. Product Data: For each type of product.

1.3 INFORMATIONAL SUBMITTALS

- A. As-Built Data: Plans showing dimensioned as-built locations of grounding features specified in "Field Quality Control" Article.
- B. Qualification Data: For testing agency and testing agency's field supervisor.
- C. Field quality-control reports.

1.4 CLOSEOUT SUBMITTALS

- A. Operation and maintenance data.
 - 1. Instructions for periodic testing and inspection of grounding features at ground rings and grounding connections for separately derived systems based on NETA MTS.
 - a. Tests shall determine if ground-resistance or impedance values remain within specified maximums, and instructions shall recommend corrective action if values do not.
 - b. Include recommended testing intervals.

1.5 QUALITY ASSURANCE

- A. Testing Agency Qualifications: Certified by NETA.

PART 2 - PRODUCTS

2.1 SYSTEM DESCRIPTION

- A. Electrical Components, Devices, and Accessories: Listed and labeled as defined in NFPA 70, by a qualified testing agency, and marked for intended location and application.
- B. Comply with UL 467 for grounding and bonding materials and equipment.

2.2 CONDUCTORS

- A. Insulated Conductors: Copper wire or cable insulated for 600 V unless otherwise required by applicable Code or authorities having jurisdiction.
- B. Bare Copper Conductors:
 - 1. Solid Conductors: ASTM B 3.
 - 2. Stranded Conductors: ASTM B 8.
 - 3. Tinned Conductors: ASTM B 33.
 - 4. Bonding Cable: 28 kcmil, 14 strands of No. 17 AWG conductor, 1/4 inch in diameter.
 - 5. Bonding Conductor: No. 4 or No. 6 AWG, stranded conductor.
 - 6. Bonding Jumper: Copper tape, braided conductors terminated with copper ferrules; 1-5/8 inches wide and 1/16 inch thick.
 - 7. Tinned Bonding Jumper: Tinned-copper tape, braided conductors terminated with copper ferrules; 1-5/8 inches wide and 1/16 inch thick.
- C. Grounding Bus: Predrilled rectangular bars of annealed copper, 1/4 by 4 inches in cross section, with 9/32-inch holes spaced 1-1/8 inches apart. Stand-off insulators for mounting shall comply with UL 891 for use in switchboards, 600 V and shall be Lexan or PVC, impulse tested at 5000 V.

2.3 CONNECTORS

- A. Listed and labeled by an NRTL acceptable to authorities having jurisdiction for applications in which used and for specific types, sizes, and combinations of conductors and other items connected.
- B. Welded Connectors: Exothermic-welding kits of types recommended by kit manufacturer for materials being joined and installation conditions.
- C. Bus-Bar Connectors: Mechanical type, cast silicon bronze, solderless compression-type wire terminals, and long-barrel, two-bolt connection to ground bus bar.
- D. Bus-Bar Connectors: Compression type, copper or copper alloy, with two wire terminals.

- E. Beam Clamps: Mechanical type, terminal, ground wire access from four directions, with dual, tin-plated or silicon bronze bolts.
- F. Cable-to-Cable Connectors: Compression type, copper or copper alloy.
- G. Conduit Hubs: Mechanical type, terminal with threaded hub.
- H. Ground Rod Clamps: Mechanical type, copper or copper alloy, terminal with hex head bolt.
- I. Lay-in Lug Connector: Mechanical type, copper rated for direct burial terminal with set screw.
- J. Service Post Connectors: Mechanical type, bronze alloy terminal, in short- and long-stud lengths, capable of single and double conductor connections.
- K. Signal Reference Grid Clamp: Mechanical type, stamped-steel terminal with hex head screw.
- L. Straps: Solid copper, cast-bronze clamp Rated for 600 A.
- M. Tower Ground Clamps: Mechanical type, copper or copper alloy, terminal one-piece clamp.
- N. U-Bolt Clamps: Mechanical type, copper or copper alloy, terminal listed for direct burial.
- O. Water Pipe Clamps:
 - 1. Mechanical type, two pieces with zinc-plated bolts.
 - a. Material: Tin-plated aluminum.
 - b. Listed for direct burial.
 - 2. U-bolt type with malleable-iron clamp and copper ground connector.

2.4 GROUNDING ELECTRODES

- A. Ground Rods: Copper-clad steel, sectional type; 3/4 inch by 10 feet.
- B. Ground Plates: 1/4 inch thick, hot-dip galvanized.

PART 3 - EXECUTION

3.1 APPLICATIONS

- A. Conductors: Install solid or stranded conductor for No. 8 AWG and smaller, and stranded conductors for No. 6 AWG and larger unless otherwise indicated.

- B. Underground Grounding Conductors: Install bare tinned-copper conductor, No. 2/0 AWG minimum.
 - 1. Bury at least 24 inches below grade.
- C. Grounding Bus: Install in electrical equipment rooms, in rooms housing service equipment, and elsewhere as indicated.
 - 1. Install bus horizontally, on insulated spacers 2 inches minimum from wall, 6 inches above finished floor unless otherwise indicated.
 - 2. Where indicated on both sides of doorways, route bus up to top of door frame, across top of doorway, and down; connect to horizontal bus.
- D. Conductor Terminations and Connections:
 - 1. Pipe and Equipment Grounding Conductor Terminations: Bolted connectors.
 - 2. Underground Connections: Welded connectors except as otherwise indicated.
 - 3. Connections to Structural Steel: Welded connectors.

3.2 GROUNDING AT THE SERVICE

- A. Equipment grounding conductors and grounding electrode conductors shall be connected to the ground bus. Install a main bonding jumper between the neutral and ground buses.

3.3 GROUNDING SEPARATELY DERIVED SYSTEMS

- A. Generator: Install grounding electrode(s) at the generator location. The electrode shall be connected to the equipment grounding conductor and to the frame of the generator.

3.4 GROUNDING UNDERGROUND DISTRIBUTION SYSTEM COMPONENTS

- A. Comply with IEEE C2 grounding requirements.
- B. Grounding Manholes and Handholes: Install a driven ground rod through manhole or handhole floor, close to wall, and set rod depth so 4 inches will extend above finished floor. If necessary, install ground rod before manhole is placed and provide No. 1/0 AWG bare, tinned-copper conductor from ground rod into manhole through a waterproof sleeve in manhole wall. Protect ground rods passing through concrete floor with a double wrapping of pressure-sensitive insulating tape or heat-shrunk insulating sleeve from 2 inches above to 6 inches below concrete. Seal floor opening with waterproof, non-shrink grout.
- C. Grounding Connections to Manhole Components: Bond exposed-metal parts such as inserts, cable racks, pulling irons, ladders, and cable shields within each manhole or handhole, to ground rod or grounding conductor. Make connections with No. 4 AWG minimum, stranded, hard-drawn copper bonding conductor. Train conductors level or plumb around corners and fasten to manhole walls. Connect to cable armor and cable

shields according to written instructions by manufacturer of splicing and termination kits.

- D. Pad-Mounted Transformers and Switches: Install two ground rods and ground ring around the pad. Ground pad-mounted equipment and noncurrent-carrying metal items associated with substations by connecting them to underground cable and grounding electrodes. Install tinned-copper conductor not less than No. 2 AWG for ground ring and for taps to equipment grounding terminals. Bury ground ring not less than 6 inches from the foundation.

3.5 EQUIPMENT GROUNDING

- A. Install insulated equipment grounding conductors with all feeders and branch circuits.
- B. Install insulated equipment grounding conductors with the following items, in addition to those required by NFPA 70:
 1. Feeders and branch circuits.
 2. Lighting circuits.
 3. Receptacle circuits.
 4. Single-phase motor and appliance branch circuits.
 5. Three-phase motor and appliance branch circuits.
 6. Flexible raceway runs.
 7. Metal-clad cable runs.
- C. Water Heater, Heat-Tracing, and Antifrost Heating Cables: Install a separate insulated equipment grounding conductor to each electric water heater and heat-tracing cable. Bond conductor to heater units, piping, connected equipment, and components.
- D. Poles Supporting Outdoor Lighting Fixtures: Install grounding electrode and a separate insulated equipment grounding conductor in addition to grounding conductor installed with branch-circuit conductors.

3.6 INSTALLATION

- A. Grounding Conductors: Route along shortest and straightest paths possible unless otherwise indicated or required by Code. Avoid obstructing access or placing conductors where they may be subjected to strain, impact, or damage.
- B. Ground Bonding Common with Lightning Protection System: Comply with NFPA 780 and UL 96 when interconnecting with lightning protection system. Bond electrical power system ground directly to lightning protection system grounding conductor at closest point to electrical service grounding electrode. Use bonding conductor sized same as system grounding electrode conductor, and install in conduit.
- C. Ground Rods: Drive rods until tops are 2 inches below finished floor or final grade unless otherwise indicated.

1. Interconnect ground rods with grounding electrode conductor below grade and as otherwise indicated. Make connections without exposing steel or damaging coating if any.
- D. Bonding Straps and Jumpers: Install in locations accessible for inspection and maintenance except where routed through short lengths of conduit.
1. Bonding to Structure: Bond straps directly to basic structure, taking care not to penetrate any adjacent parts.
 2. Bonding to Equipment Mounted on Vibration Isolation Hangers and Supports: Install bonding so vibration is not transmitted to rigidly mounted equipment.
 3. Use exothermic-welded connectors for outdoor locations; if a disconnect-type connection is required, use a bolted clamp.
- E. Grounding and Bonding for Piping:
1. Metal Water Service Pipe: Install insulated copper grounding conductors, in conduit, from building's main service equipment, or grounding bus, to main metal water service entrances to building. Connect grounding conductors to main metal water service pipes; use a bolted clamp connector or bolt a lug-type connector to a pipe flange by using one of the lug bolts of the flange. Where a dielectric main water fitting is installed, connect grounding conductor on street side of fitting. Bond metal grounding conductor conduit or sleeve to conductor at each end.
 2. Water Meter Piping: Use braided-type bonding jumpers to electrically bypass water meters. Connect to pipe with a bolted connector.
 3. Bond each aboveground portion of gas piping system downstream from equipment shutoff valve.

3.7 FIELD QUALITY CONTROL

- A. Tests and Inspections:
1. After installing grounding system but before permanent electrical circuits have been energized, test for compliance with requirements.
 2. Inspect physical and mechanical condition. Verify tightness of accessible, bolted, electrical connections with a calibrated torque wrench according to manufacturer's written instructions.
 3. Test completed grounding system at each location where a maximum ground-resistance level is specified, at service disconnect enclosure grounding terminal, at individual ground rods. Make tests at ground rods before any conductors are connected.
 - a. Measure ground resistance no fewer than two full days after last trace of precipitation and without soil being moistened by any means other than natural drainage or seepage and without chemical treatment or other artificial means of reducing natural ground resistance.
 - b. Perform tests by fall-of-potential method according to IEEE 81.

4. Prepare dimensioned Drawings locating each test well, ground rod and ground-rod assembly, and other grounding electrodes. Identify each by letter in alphabetical order, and key to the record of tests and observations. Include the number of rods driven and their depth at each location, and include observations of weather and other phenomena that may affect test results. Describe measures taken to improve test results.
- B. Grounding system will be considered defective if it does not pass tests and inspections.
- C. Prepare test and inspection reports.
- D. Report measured ground resistances that exceed the following values:
1. Power and Lighting Equipment or System with Capacity of 500 kVA and Less: 10 ohms.
 2. Power and Lighting Equipment or System with Capacity of 500 to 1000 kVA: 5 ohms.
 3. Power and Lighting Equipment or System with Capacity More Than 1000 kVA: 3 ohms.
 4. Power Distribution Units or Panelboards Serving Electronic Equipment: 3 ohm.
 5. Substations and Pad-Mounted Equipment: 5 ohms.
- E. Excessive Ground Resistance: If resistance to ground exceeds specified values, notify Architect promptly and include recommendations to reduce ground resistance.

END OF SECTION

SECTION 16461

LOW-VOLTAGE TRANSFORMERS

PART 1 - GENERAL

1.1 SUMMARY

- A. Section Includes: Dry-type transformers rated 600 V and less, with capacities up to 1500 kVA.

1.2 ACTION SUBMITTALS

- A. Product Data: For each type of product.
- B. Shop Drawings:
 - 1. Detail equipment assemblies and indicate dimensions, weights, loads, required clearances, method of field assembly, components, and location and size of each field connection.
 - 2. Vibration Isolation Base Details: Detail fabrication including anchorages and attachments to structure and to supported equipment.
 - 3. Include diagrams for power, signal, and control wiring.

1.3 INFORMATIONAL SUBMITTALS

- A. Seismic Qualification Certificates: For transformers, accessories, and components, from manufacturer.
- B. Qualification Data: For testing agency.
- C. Source quality-control reports.
- D. Field quality-control reports.

1.4 CLOSEOUT SUBMITTALS

- A. Operation and maintenance data.

1.5 QUALITY ASSURANCE

- A. Testing Agency Qualifications: Accredited by NETA.
 - 1. Testing Agency's Field Supervisor: Certified by NETA to supervise on-site testing.

1.6 DELIVERY, STORAGE, AND HANDLING

- A. Temporary Heating: Apply temporary heat according to manufacturer's written instructions.

PART 2 - PRODUCTS

2.1 GENERAL TRANSFORMER REQUIREMENTS

- A. Description: Factory-assembled and -tested, air-cooled units for 60-Hz service.
- B. Electrical Components, Devices, and Accessories: Listed and labeled as defined in NFPA 70, by a qualified testing agency, and marked for intended location and application.
- C. Transformers Rated 15 kVA and Larger: Comply with NEMA TP 1 energy-efficiency levels as verified by testing according to NEMA TP 2.
 - 1. Coil Material: Copper.
- D. Encapsulation: Transformers smaller than 30 kVA shall have core and coils completely resin encapsulated.

2.2 DISTRIBUTION TRANSFORMERS

- A. Comply with NFPA 70, and list and label as complying with UL 1561.
- B. Cores: One leg per phase.
- C. Enclosure: Ventilated.
 - 1. NEMA 250, Type 2: Core and coil shall be encapsulated within resin compound utilizing a vacuum pressure impregnation process to seal out moisture and air.
- D. Transformer Enclosure Finish: Comply with NEMA 250.
 - 1. Finish Color: NSF/ANSI 49 gray.
- E. Taps for Transformers 3 kVA and Smaller: None.
- F. Taps for Transformers 7.5 to 24 kVA: One 5 percent tap above and one 5 percent tap below normal full capacity.
- G. Taps for Transformers 25 kVA and Larger: Two 2.5 percent taps above and four 2.5 percent taps below normal full capacity.

- H. Insulation Class, Smaller than 30 kVA: 185 deg C, UL-component-recognized insulation system with a maximum of 115-deg C rise above 40-deg C ambient temperature.
- I. Insulation Class, 30 kVA and Larger: 220 deg C, UL-component-recognized insulation system with a maximum of 115-deg C rise above 40-deg C ambient temperature.
- J. K-Factor Rating: Transformers indicated to be K-factor rated shall comply with UL 1561 requirements for nonsinusoidal load current-handling capability to the degree defined by designated K-factor.
 - 1. Unit shall not overheat when carrying full-load current with harmonic distortion corresponding to designated K-factor.
 - 2. Indicate value of K-factor on transformer nameplate.
 - 3. Unit shall meet requirements of NEMA TP 1 when tested according to NEMA TP 2 with a K-factor equal to one.
- K. Electrostatic Shielding: Each winding shall have an independent, single, full-width copper electrostatic shield arranged to minimize interwinding capacitance.
 - 1. Arrange coil leads and terminal strips to minimize capacitive coupling between input and output terminals.
 - 2. Include special terminal for grounding the shield.
- L. Neutral: Rated 200 percent of full load current for K-factor rated transformers.
- M. Wall Brackets: Manufacturer's standard brackets.

2.3 IDENTIFICATION DEVICES

- A. Nameplates: Engraved, laminated-plastic or metal nameplate for each distribution transformer, mounted with corrosion-resistant screws. Nameplates and label products are specified in Section 16052 "Identification for Electrical Systems."

2.4 SOURCE QUALITY CONTROL

- A. Test and inspect transformers according to IEEE C57.12.01 and IEEE C57.12.91.

PART 3 - EXECUTION

3.1 INSTALLATION

- A. Verify that ground connections are in place and requirements in Section 16450 "Grounding and Bonding for Electrical Systems" have been met. Maximum ground resistance shall be 5 ohms at location of transformer.
- B. Environment: Enclosures shall be rated for the environment in which they are located. Covers for NEMA 250, Type 4X enclosures shall not cause accessibility problems.

- C. Proceed with installation only after unsatisfactory conditions have been corrected.
- D. Install wall-mounted transformers level and plumb with wall brackets fabricated by transformer manufacturer.
 - 1. Coordinate installation of wall-mounted and structure-hanging supports with actual transformer provided.
- E. Install transformers level and plumb on a concrete base with vibration-dampening supports. Locate transformers away from corners and not parallel to adjacent wall surface.
- F. Construct concrete bases according to Section 03300 "Cast-in-Place Concrete" and anchor floor-mounted transformers according to manufacturer's written instructions and requirements in Section 16050 "Hangers and Supports for Electrical Systems."
 - 1. Coordinate size and location of concrete bases with actual transformer provided. Cast anchor-bolt inserts into bases. Concrete, reinforcement, and formwork requirements are specified with concrete.
- G. Secure transformer to concrete base according to manufacturer's written instructions.
- H. Secure covers to enclosure and tighten all bolts to manufacturer-recommended torques to reduce noise generation.
- I. Remove shipping bolts, blocking, and wedges.

3.2 CONNECTIONS

- A. Ground equipment according to Section 16450 "Grounding and Bonding for Electrical Systems."
- B. Connect wiring according to Section 16120 "Low-Voltage Electrical Power Conductors and Cables."
- C. Tighten electrical connectors and terminals according to manufacturer's published torque-tightening values. If manufacturer's torque values are not indicated, use those specified in UL 486A-486B.
- D. Provide flexible connections at all conduit and conductor terminations and supports to eliminate sound and vibration transmission to the building structure.

3.3 FIELD QUALITY CONTROL

- A. Perform tests and inspections and prepare test reports.
 - 1. Perform each visual and mechanical inspection and electrical test stated in NETA ATS for dry-type, air-cooled, low-voltage transformers. Certify compliance with test parameters.

- B. Remove and replace units that do not pass tests or inspections and retest as specified above.
- C. Infrared Scanning: Two months after Substantial Completion, perform an infrared scan of transformer connections.
 - 1. Use an infrared-scanning device designed to measure temperature or detect significant deviations from normal values. Provide documentation of device calibration.
 - 2. Perform two follow-up infrared scans of transformers, one at four months and the other at 11 months after Substantial Completion.
 - 3. Prepare a certified report identifying transformer checked and describing results of scanning. Include notation of deficiencies detected, remedial action taken, and scanning observations after remedial action.

3.4 ADJUSTING

- A. Record transformer secondary voltage at each unit for at least 48 hours of typical occupancy period. Adjust transformer taps to provide optimum voltage conditions at secondary terminals. Optimum is defined as not exceeding nameplate voltage plus 5 percent and not being lower than nameplate voltage minus 3 percent at maximum load conditions. Submit recording and tap settings as test results.
- B. Connect buck-boost transformers to provide nameplate voltage of equipment being served, plus or minus 5 percent, at secondary terminals.
- C. Output Settings Report: Prepare a written report recording output voltages and tap settings.

END OF SECTION

SECTION 16472

PANELBOARDS

PART 1 - GENERAL

1.1 SUMMARY

A. Section Includes:

1. Distribution panelboards.
2. Lighting and appliance branch-circuit panelboards.

1.2 DEFINITIONS

A. MCCB: Molded-case circuit breaker.

B. SPD: Surge protective device.

1.3 ACTION SUBMITTALS

A. Product Data: For each type of panelboard.

B. Shop Drawings: For each panelboard and related equipment.

1. Include dimensioned plans, elevations, sections, and details.
2. Detail enclosure types including mounting and anchorage, environmental protection, knockouts, corner treatments, covers and doors, gaskets, hinges, and locks.
3. Detail bus configuration, current, and voltage ratings.
4. Short-circuit current rating of panelboards and overcurrent protective devices.
5. Include evidence of NRTL listing for series rating of installed devices.
6. Include evidence of NRTL listing for SPD as installed in panelboard.
7. Detail features, characteristics, ratings, and factory settings of individual overcurrent protective devices and auxiliary components.
8. Include wiring diagrams for power, signal, and control wiring.

1.4 INFORMATIONAL SUBMITTALS

A. Panelboard schedules for installation in panelboards.

1.5 CLOSEOUT SUBMITTALS

A. Operation and maintenance data.

1.6 FIELD CONDITIONS

A. Service Conditions: NEMA PB 1, usual service conditions, as follows:

1. Ambient temperatures within limits specified.
2. Altitude not exceeding 6600 feet.

1.7 WARRANTY

A. Manufacturer's Warranty: Manufacturer agrees to repair or replace panelboards that fail in materials or workmanship within specified warranty period.

1. Panelboard Warranty Period: 18 months from date of Substantial Completion.

PART 2 - PRODUCTS

2.1 PANELBOARDS COMMON REQUIREMENTS

A. Electrical Components, Devices, and Accessories: Listed and labeled as defined in NFPA 70, by a qualified testing agency, and marked for intended location and application.

B. Comply with NEMA PB 1.

C. Comply with NFPA 70.

D. Enclosures: Flush and Surface-mounted, dead-front cabinets.

1. Rated for environmental conditions at installed location.
 - a. Indoor Dry and Clean Locations: NEMA 250, Type 1.
 - b. Outdoor Locations: NEMA 250, Type 3R.
 - c. Other Wet or Damp Indoor Locations: NEMA 250, Type 4.
2. Height: 84 inches maximum.
3. Front: Secured to box with concealed trim clamps. For surface-mounted fronts, match box dimensions; for flush-mounted fronts, overlap box. Trims shall cover all live parts and shall have no exposed hardware.
4. Hinged Front Cover: Entire front trim hinged to box and with standard door within hinged trim cover. Trims shall cover all live parts and shall have no exposed hardware.

E. Incoming Mains Location: Convertible between top and bottom.

F. Phase, Neutral, and Ground Buses: Hard-drawn copper, 98 percent conductivity.

G. Conductor Connectors: Suitable for use with conductor material and sizes.

1. Material: Hard-drawn copper, 98 percent conductivity.

2. Main and Neutral Lugs: Mechanical type, with a lug on the neutral bar for each pole in the panelboard.
 3. Ground Lugs and Bus-Configured Terminators: Mechanical type, with a lug on the bar for each pole in the panelboard.
 4. Feed-Through Lugs: Mechanical type, suitable for use with conductor material. Locate at opposite end of bus from incoming lugs or main device.
 5. Subfeed (Double) Lugs: Mechanical type suitable for use with conductor material. Locate at same end of bus as incoming lugs or main device.
- H. NRTL Label: Panelboards shall be labeled by an NRTL acceptable to authority having jurisdiction for use as service equipment with one or more main service disconnecting and overcurrent protective devices. Panelboards shall have meter enclosures, wiring, connections, and other provisions for utility metering. Coordinate with utility company for exact requirements.
- I. Future Devices: Panelboards shall have mounting brackets, bus connections, filler plates, and necessary appurtenances required for future installation of devices.
- J. Panelboard Short-Circuit Current Rating: Rated for series-connected system with integral or remote upstream overcurrent protective devices and labeled by an NRTL. Include label or manual with size and type of allowable upstream and branch devices listed and labeled by an NRTL for series-connected short-circuit rating.
- K. Panelboard Short-Circuit Current Rating: Fully rated to interrupt symmetrical short-circuit current available at terminals. Assembly listed by an NRTL for 100 percent interrupting capacity.

2.2 PERFORMANCE REQUIREMENTS

- A. Seismic Performance: Panelboards shall withstand the effects of earthquake motions determined according to ASCE/SEI 7.
1. The term "withstand" means "the unit will remain in place without separation of any parts from the device when subjected to the seismic forces specified."
- B. Surge Suppression: Factory installed as an integral part of indicated panelboards, complying with UL 1449 SPD Type 1.

2.3 POWER PANELBOARDS

- A. Panelboards: NEMA PB 1, distribution type.
- B. Doors: Secured with vault-type latch with tumbler lock; keyed alike.
1. For doors more than 36 inches high, provide two latches, keyed alike.
- C. Mains: Circuit breaker or Lugs only.

- D. Branch Overcurrent Protective Devices for Circuit-Breaker Frame Sizes 125 A and Smaller: Bolt-on circuit breakers.
- E. Branch Overcurrent Protective Devices for Circuit-Breaker Frame Sizes Larger Than 125 A: Bolt-on circuit breakers.
- F. Branch Overcurrent Protective Devices: Fused switches.

2.4 LIGHTING AND APPLIANCE BRANCH-CIRCUIT PANELBOARDS

- A. Panelboards: NEMA PB 1, lighting and appliance branch-circuit type.
- B. Mains: Circuit breaker or lugs only.
- C. Branch Overcurrent Protective Devices: Bolt-on circuit breakers, replaceable without disturbing adjacent units.
- D. Doors: Concealed hinges; secured with flush latch with tumbler lock; keyed alike.
- E. Column-Type Panelboards: Single row of overcurrent devices with narrow gutter extension and overhead junction box equipped with ground and neutral terminal buses.

2.5 DISCONNECTING AND OVERCURRENT PROTECTIVE DEVICES

- A. MCCB: Comply with UL 489, with interrupting capacity to meet available fault currents.
 - 1. Thermal-Magnetic Circuit Breakers:
 - a. Inverse time-current element for low-level overloads.
 - b. Instantaneous magnetic trip element for short circuits.
 - c. Adjustable magnetic trip setting for circuit-breaker frame sizes 250 A and larger.
 - 2. Adjustable Instantaneous-Trip Circuit Breakers: Magnetic trip element with front-mounted, field-adjustable trip setting.
 - 3. Electronic Trip Circuit Breakers:
 - a. RMS sensing.
 - b. Field-replaceable rating plug or electronic trip.
 - c. Digital display of settings, trip targets, and indicated metering displays.
 - d. Multi-button keypad to access programmable functions and monitored data.
 - e. Ten-event, trip-history log. Each trip event shall be recorded with type, phase, and magnitude of fault that caused the trip.
 - f. Integral test jack for connection to portable test set or laptop computer.
 - g. Field-Adjustable Settings:
 - 1) Instantaneous trip.
 - 2) Long- and short-time pickup levels.

- 3) Long and short time adjustments.
 - 4) Ground-fault pickup level, time delay, and I squared T response.
4. Current-Limiting Circuit Breakers: Frame sizes 400 A and smaller; let-through ratings less than NEMA FU 1, RK-5.
 5. GFCI Circuit Breakers: Single- and double-pole configurations with Class A ground-fault protection (6-mA trip).
 6. GFEP Circuit Breakers: Class B ground-fault protection (30-mA trip).
 7. Arc-Fault Circuit Interrupter Circuit Breakers: Comply with UL 1699; 120/240-V, single-pole configuration.
 8. Subfeed Circuit Breakers: Vertically mounted.
 9. MCCB Features and Accessories:
 - a. Standard frame sizes, trip ratings, and number of poles.
 - b. Breaker handle indicates tripped status.
 - c. UL listed for reverse connection without restrictive line or load ratings.
 - d. Lugs: Mechanical style, suitable for number, size, trip ratings, and conductor materials.
 - e. Application Listing: Appropriate for application; Type SWD for switching fluorescent lighting loads; Type HID for feeding fluorescent and HID lighting circuits.
 - f. Handle Padlocking Device: Fixed attachment, for locking circuit-breaker handle in on or off position.
 - g. Handle Clamp: Loose attachment, for holding circuit-breaker handle in on position.

2.6 IDENTIFICATION

- A. Panelboard Label: Manufacturer's name and trademark, voltage, amperage, number of phases, and number of poles shall be located on the interior of the panelboard door.
- B. Breaker Labels: Faceplate shall list current rating, UL and IEC certification standards, and AIC rating.
- C. Circuit Directory: Directory card inside panelboard door, mounted in metal frame with transparent protective cover.

PART 3 - EXECUTION

3.1 INSTALLATION

- A. Comply with NECA 1.
- B. Install panelboards and accessories according to NECA 407.
- C. Mount top of trim 90 inches above finished floor unless otherwise indicated.
- D. Mount panelboard cabinet plumb and rigid without distortion of box.

- E. Mount recessed panelboards with fronts uniformly flush with wall finish and mating with back box.
- F. Install overcurrent protective devices and controllers not already factory installed.
 - 1. Set field-adjustable, circuit-breaker trip ranges.
- G. Make grounding connections and bond neutral for services and separately derived systems to ground. Make connections to grounding electrodes, separate grounds for isolated ground bars, and connections to separate ground bars.
- H. Install filler plates in unused spaces.
- I. Stub four 1-inch empty conduits from panelboard into accessible ceiling space or space designated to be ceiling space in the future. Stub four 1-inch empty conduits into raised floor space or below slab not on grade.
- J. Arrange conductors in gutters into groups and bundle and wrap with wire ties.

3.2 IDENTIFICATION

- A. Identify field-installed conductors, interconnecting wiring, and components; install warning signs complying with requirements in Section 16052 "Identification for Electrical Systems."
- B. Create a directory to indicate installed circuit loads; incorporate Owner's final room designations. Obtain approval before installing. Handwritten directories are not acceptable. Install directory inside panelboard door.
- C. Panelboard Nameplates: Label each panelboard with a nameplate complying with requirements for identification specified in Section 16052 "Identification for Electrical Systems."
- D. Device Nameplates: Label each branch circuit device in power panelboards with a nameplate complying with requirements for identification specified in Section 16052 "Identification for Electrical Systems."
- E. Install warning signs complying with requirements in Section 16052 "Identification for Electrical Systems" identifying source of remote circuit.

3.3 FIELD QUALITY CONTROL

- A. Perform tests and inspections.
- B. Acceptance Testing Preparation:
 - 1. Test insulation resistance for each panelboard bus, component, connecting supply, feeder, and control circuit.
 - 2. Test continuity of each circuit.

- C. Tests and Inspections:
 - 1. Perform each visual and mechanical inspection and electrical test for low-voltage air circuit breakers stated in NETA Acceptance Testing Specification. Certify compliance with test parameters.
 - 2. Correct malfunctioning units on-site, where possible, and retest to demonstrate compliance; otherwise, replace with new units and retest.
- D. Panelboards will be considered defective if they do not pass tests and inspections.
- E. Prepare test and inspection reports, including a certified report that identifies panelboards included and that describes scanning results, with comparisons of the two scans. Include notation of deficiencies detected, remedial action taken, and observations after remedial action.

END OF SECTION

SECTION 16510

LED INTERIOR LIGHTING

PART 1 - GENERAL

1.1 SUMMARY

A. Section Includes:

1. Interior solid-state luminaires that use LED technology.
2. Lighting fixture supports.

B. Related Requirements:

1. Section 16512 "Lighting Control Devices" for automatic control of lighting, including time switches, photoelectric relays, occupancy sensors, and multipole lighting relays and contactors.

1.2 DEFINITIONS

A. CCT: Correlated color temperature.

B. CRI: Color Rendering Index.

C. Fixture: See "Luminaire."

D. IP: International Protection or Ingress Protection Rating.

E. LED: Light-emitting diode.

F. Lumen: Measured output of lamp and luminaire, or both.

G. Luminaire: Complete lighting unit, including lamp, reflector, and housing.

1.3 ACTION SUBMITTALS

A. Product Data: For each type of product, arranged by designation.

B. Shop Drawings: For nonstandard or custom luminaires.

1. Include plans, elevations, sections, and mounting and attachment details.
2. Include details of luminaire assemblies. Indicate dimensions, weights, loads, required clearances, method of field assembly, components, and location and size of each field connection.
3. Include diagrams for power, signal, and control wiring.

C. Product Schedule: For luminaires and lamps. Use same designations indicated on Drawings.

1.4 INFORMATIONAL SUBMITTALS

- A. Coordination Drawings: Reflected ceiling plan(s) and other details, drawn to scale and coordinated with each other, using input from installers of the items involved:
- B. Seismic Qualification Certificates: For luminaires, accessories, and components, from manufacturer.
- C. Product Certificates: For each type of luminaire.
- D. Sample warranty.

1.5 CLOSEOUT SUBMITTALS

- A. Operation and maintenance data.

1.6 WARRANTY

- A. Warranty: Manufacturer and Installer agree to repair or replace components of luminaires that fail in materials or workmanship within specified warranty period.
- B. Warranty Period: Five year(s) from date of Substantial Completion.

PART 2 - PRODUCTS

2.1 PERFORMANCE REQUIREMENTS

- A. Seismic Performance: Luminaires shall withstand the effects of earthquake motions determined according to ASCE/SEI 7.
- B. Seismic Performance: Luminaires and lamps shall be labeled vibration and shock resistant.
 - 1. The term "withstand" means "the luminaire will remain in place without separation of any parts when subjected to the seismic forces specified and the luminaire will be fully operational during and after the seismic event."

2.2 LUMINAIRE REQUIREMENTS

- A. Electrical Components, Devices, and Accessories: Listed and labeled as defined in NFPA 70, by a qualified testing agency, and marked for intended location and application.
- B. NRTL Compliance: Luminaires for hazardous locations shall be listed and labeled for indicated class and division of hazard by an NRTL.

- C. FM Global Compliance: Luminaires for hazardous locations shall be listed and labeled for indicated class and division of hazard by FM Global.
- D. Recessed Fixtures: Comply with NEMA LE 4.
- E. CRI of minimum 65. CCT of 3000 K.
- F. Rated lamp life of 50,000 hours.
- G. Lamps dimmable from 100 percent to 0 percent of maximum light output.
- H. Internal driver.
- I. Nominal Operating Voltage: 120 V ac/277 V ac.
 - 1. Lens Thickness: At least 0.125 inch minimum unless otherwise indicated.
- J. Housings:
 - 1. Extruded-aluminum housing and heat sink.

2.3 CYLINDER

- A. Minimum 575 lumens. Minimum allowable efficacy of 80 lumens per watt.
- B. With integral mounting provisions.

2.4 DOWNLIGHT

- A. Minimum 1,000 lumens. Minimum allowable efficacy of 80 lumens per watt.
- B. Universal mounting bracket.
- C. Integral junction box with conduit fittings.

2.5 LOWBAY

- A. Minimum 5,000 lumens. Minimum allowable efficacy of 80 lumens per watt.
- B. Universal mounting bracket.

2.6 RECESSED LINEAR

- A. Minimum 1,500 lumens. Minimum allowable efficacy of 85 lumens per watt.
- B. Integral junction box with conduit fittings.

2.7 STRIP LIGHT

- A. Minimum 750 lumens. Minimum allowable efficacy of 80 lumens per watt.
- B. Integral junction box with conduit fittings.

2.8 SURFACE MOUNT, LINEAR

- A. Minimum 750 lumens. Minimum allowable efficacy of 80 lumens per watt.
- B. Integral junction box with conduit fittings.

2.9 SURFACE MOUNT, NONLINEAR

- A. Minimum 750 lumens. Minimum allowable efficacy of 80 lumens per watt.
- B. Integral junction box with conduit fittings.

2.10 SUSPENDED, LINEAR

- A. Minimum 1,500 lumens. Minimum allowable efficacy of 85 lumens per watt.

2.11 SUSPENDED, NONLINEAR

- A. Minimum 1,500 lumens. Minimum allowable efficacy of 85 lumens per watt.
- B. Integral junction box with conduit fittings.

2.12 MATERIALS

- A. Metal Parts:
 - 1. Free of burrs and sharp corners and edges.
 - 2. Sheet metal components shall be steel unless otherwise indicated.
 - 3. Form and support to prevent warping and sagging
- B. Doors, Frames, and Other Internal Access: Smooth operating, free of light leakage under operating conditions, and designed to permit relamping without use of tools. Designed to prevent doors, frames, lenses, diffusers, and other components from falling accidentally during relamping and when secured in operating position.

2.13 METAL FINISHES

- A. Variations in finishes are unacceptable in the same piece. Variations in finishes of adjoining components are acceptable if they are within the range of approved Samples and if they can be and are assembled or installed to minimize contrast.

2.14 LUMINAIRE SUPPORT COMPONENTS

- A. Comply with requirements in Section 16050 "Hangers and Supports for Electrical Systems" for channel and angle iron supports and nonmetallic channel and angle supports.
- B. Single-Stem Hangers: 1/2-inch steel tubing with swivel ball fittings and ceiling canopy. Finish same as luminaire.
- C. Wires: ASTM A 641/A 641 M, Class 3, soft temper, zinc-coated steel, 12 gage.
- D. Rod Hangers: 3/16-inch minimum diameter, cadmium-plated, threaded steel rod.
- E. Hook Hangers: Integrated assembly matched to luminaire, line voltage, and equipment with threaded attachment, cord, and locking-type plug.

PART 3 - EXECUTION

3.1 INSTALLATION

- A. Comply with NECA 1.
- B. Install luminaires level, plumb, and square with ceilings and walls unless otherwise indicated.
- C. Install lamps in each luminaire.
- D. Supports: Sized and rated for luminaire weight.
- E. Flush-Mounted Luminaire Support: Secured to outlet box.
- F. Wall-Mounted Luminaire Support:
 - 1. Attached to structural members in walls.
 - 2. Do not attach luminaires directly to gypsum board.
- G. Ceiling-Mounted Luminaire Support:
 - 1. Ceiling mount with two 5/32-inch diameter aircraft cable supports adjustable to 120 inches in length.
 - 2. Ceiling mount with hook mount.
- H. Suspended Luminaire Support:
 - 1. Pendants and Rods: Where longer than 48 inches, brace to limit swinging.
 - 2. Stem-Mounted, Single-Unit Luminaires: Suspend with twin-stem hangers. Support with approved outlet box and accessories that hold stem and provide damping of luminaire oscillations. Support outlet box vertically to building structure using approved devices.

3. Continuous Rows of Luminaires: Use tubing or stem for wiring at one point and tubing or rod or wire support for suspension for each unit length of luminaire chassis, including one at each end.
4. Do not use ceiling grid as support for pendant luminaires. Connect support wires or rods to building structure.

I. Ceiling-Grid-Mounted Luminaires:

1. Secure to any required outlet box.
2. Secure luminaire using approved fasteners in a minimum of four locations, spaced near corners of luminaire.

J. Comply with requirements in Section 16120 "Low-Voltage Electrical Power Conductors and Cables" for wiring connections.

K. Identify system components, wiring, cabling, and terminals. Comply with requirements for identification specified in Section 16052 "Identification for Electrical Systems."

3.2 FIELD QUALITY CONTROL

A. Perform the following tests and inspections:

1. Operational Test: After installing luminaires, switches, and accessories, and after electrical circuitry has been energized, test units to confirm proper operation.
2. Test for Emergency Lighting: Interrupt power supply to demonstrate proper operation. Verify transfer from normal power to battery power and retransfer to normal.

B. Luminaire will be considered defective if it does not pass operation tests and inspections.

C. Prepare test and inspection reports.

END OF SECTION

SECTION 16511

EMERGENCY AND EXIT LIGHTING

PART 1 - GENERAL

1.1 SUMMARY

- A. Section Includes:
 - 1. Exit signs.
 - 2. Luminaire supports.

1.2 DEFINITIONS

- A. CCT: Correlated color temperature.
- B. CRI: Color Rendering Index.
- C. Emergency Lighting Unit: A lighting unit with integral or remote emergency battery powered supply and the means for controlling and charging the battery and unit operation.
- D. Fixture: See "Luminaire" Paragraph.
- E. Lumen: Measured output of lamp and luminaire, or both.
- F. Luminaire: Complete lighting unit, including lamp, reflector, and housing.

1.3 ACTION SUBMITTALS

- A. Product Data: For each type of emergency lighting unit, exit sign, and emergency lighting support, arranged by designation.
- B. Shop Drawings: For nonstandard or custom luminaires.
 - 1. Include plans, elevations, sections, and mounting and attachment details.
 - 2. Include details of equipment assemblies. Indicate dimensions, weights, loads, required clearances, method of field assembly, components, and location and size of each field connection.
 - 3. Include diagrams for power, signal, and control wiring.
- C. Sustainable Design Submittals:
 - 1. Product Data: Indicating luminaire is certified by ENERGY STAR.

1.4 INFORMATIONAL SUBMITTALS

- A. Coordination Drawings: Reflected ceiling plan(s) and other details, drawn to scale, coordinated with each other, using input from installers of the items involved:
- B. Product Certificates: For each type of luminaire.
- C. Seismic Qualification Certificates: For luminaires, accessories, and components, from manufacturer.
- D. Sample Warranty.

1.5 CLOSEOUT SUBMITTALS

- A. Operation and maintenance data.

1.6 WARRANTY

- A. Warranty: Manufacturer and Installer agree to repair or replace components of luminaires that fail in materials or workmanship within specified warranty period.
 - 1. Warranty Period: Two year(s) from date of Substantial Completion.
- B. Special Warranty for Emergency Lighting Batteries: Manufacturer's standard form in which manufacturer of battery-powered emergency lighting unit agrees to repair or replace components of rechargeable batteries that fail in materials or workmanship within specified warranty period.

PART 2 - PRODUCTS

2.1 PERFORMANCE REQUIREMENTS

- A. Seismic Performance: Luminaires shall withstand the effects of earthquake motions determined according to ASCE/SEI 7. Luminaires and lamps shall be labeled vibration and shock resistant.
 - 1. The term "withstand" means "the luminaire will remain in place without separation of any parts when subjected to the seismic forces specified and the luminaire will be fully operational during and after the seismic event."

2.2 EXIT SIGNS

- A. Internally Lighted Signs:
 - 1. Operating at nominal voltage of 120 V ac/277 V ac.
 - 2. Lamps for AC Operation: LEDs; 50,000 hours minimum rated lamp life.
 - 3. Self-Powered Exit Signs (Battery Type): Internal emergency power unit.

2.3 MATERIALS

A. Metal Parts:

1. Free of burrs and sharp corners and edges.
2. Sheet metal components shall be steel unless otherwise indicated.
3. Form and support to prevent warping and sagging.

B. Doors, Frames, and Other Internal Access:

1. Smooth operating, free of light leakage under operating conditions.
2. Designed to permit relamping without use of tools.
3. Designed to prevent doors, frames, lenses, diffusers, and other components from falling accidentally during relamping and when secured in operating position.

C. Conduit: Electrical metallic tubing or Flexible metallic conduit, minimum 3/4 inch in diameter.

2.4 METAL FINISHES

- ### A. Appearance of Finished Work: Noticeable variations in same piece are not acceptable. Variations in appearance of adjoining components are acceptable if they are within the range of approved Samples and are assembled or installed to minimize contrast.

2.5 LUMINAIRE SUPPORT COMPONENTS

- ### A. Comply with requirements in Section 16050 "Hangers and Supports for Electrical Systems" for channel and angle iron supports and nonmetallic channel and angle supports.

PART 3 - EXECUTION

3.1 INSTALLATION

- ### A. Comply with NECA 1.

- ### B. Install luminaires level, plumb, and square with ceilings and walls unless otherwise indicated.

- ### C. Install lamps in each luminaire.

- ### D. Supports:

1. Sized and rated for luminaire and emergency power unit weight.
2. Able to maintain luminaire position when testing emergency power unit.
3. Provide support for luminaire and emergency power unit without causing deflection of ceiling or wall.

4. Luminaire-mounting devices shall be capable of supporting a horizontal force of 100 percent of luminaire and emergency power unit weight and vertical force of 400 percent of fixture weight.

E. Wall-Mounted Luminaire Support:

1. Attached to structural members in walls.
2. Do not attach fixtures directly to gypsum board.

F. Suspended Luminaire Support:

1. Pendants and Rods: Where longer than 48 inches, brace to limit swinging.
2. Stem-Mounted, Single-Unit Fixtures: Suspend with twin-stem hangers. Support with approved outlet box and accessories that hold stem and provide damping of fixture oscillations. Support outlet box vertically to building structure using approved devices.
3. Continuous Rows of Luminaires: Use tubing or stem for wiring at one point and tubing rod, wire support for suspension for each unit length of fixture chassis, including one at each end.
4. Do not use ceiling grid as support for pendant luminaires. Connect support wires or rods to building structure.

G. Ceiling Grid Mounted Luminaires:

1. Secure to any required outlet box.
2. Secure emergency power unit using approved fasteners in a minimum of four locations, spaced near corners of emergency power unit.

H. Identify system components, wiring, cabling, and terminals. Comply with requirements for identification specified in Section 16052 "Identification for Electrical Systems."

3.2 FIELD QUALITY CONTROL

A. Perform the following tests and inspections:

1. Test for Emergency Lighting: Interrupt power supply to demonstrate proper operation. Verify transfer from normal power to battery power and retransfer to normal.

B. Luminaire will be considered defective if it does not pass operation tests and inspections.

C. Prepare test and inspection reports.

END OF SECTION

SECTION 16512

LIGHTING CONTROL DEVICES

PART 1 - GENERAL

1.1 SUMMARY

A. Section Includes:

1. Time switches.
2. Photoelectric switches.
3. Indoor occupancy and vacancy sensors.
4. Switchbox-mounted occupancy and vacancy sensors
5. Digital timer light switches.
6. Outdoor motion sensors.
7. Lighting contactors.

B. Related Requirements:

1. Section 16130 "Wiring Devices" for wall-box dimmers, non-networkable wall-switch occupancy sensors, and manual light switches.

1.2 ACTION SUBMITTALS

A. Product Data: For each type of product.

B. Shop Drawings:

1. Show installation details for the following:
 - a. Occupancy sensors.
 - b. Vacancy sensors.
2. Interconnection diagrams showing field-installed wiring.
3. Include diagrams for power, signal, and control wiring.

1.3 INFORMATIONAL SUBMITTALS

- A. Coordination Drawings: Reflected ceiling plan(s) and elevations, drawn to scale and coordinated with each other, using input from installers of the items involved.
- B. Field quality-control reports.
- C. Sample warranty.

1.4 CLOSEOUT SUBMITTALS

- A. Operation and maintenance data.
- B. Software and firmware operational documentation.

1.5 WARRANTY

- A. Manufacturer's Warranty: Manufacturer and Installer agree to repair or replace lighting control devices that fail(s) in materials or workmanship within specified warranty period.
 1. Warranty Period: Two year(s) from date of Substantial Completion.

PART 2 - PRODUCTS

2.1 TIME SWITCHES

- A. Electronic Time Switches: Solid state, programmable, with alphanumeric display; complying with UL 917.
 1. Listed and labeled as defined in NFPA 70, by a qualified testing agency, and marked for intended location and application.
 2. Contact Configuration: SPST.
 3. Contact Rating: 30-A inductive or resistive, 277-V ac.
 4. Programs: Eight on-off set points on a 24-hour schedule and an annual holiday schedule that overrides the weekly operation on holidays.
 5. Programs: Two on-off set points on a 24-hour schedule, allowing different set points for each day of the week and an annual holiday schedule that overrides the weekly operation on holidays.
 6. Programs: Four channels; each channel is individually programmable with eight on-off set points on a 24-hour schedule.
 7. Programs: Annual holiday schedule that overrides the weekly operation on holidays.
 8. Circuitry: Allow connection of a photoelectric relay as substitute for on-off function of a program.
 9. Astronomic Time: All channels.
 10. Automatic daylight savings time changeover.
 11. Battery Backup: Not less than seven days reserve, to maintain schedules and time clock.

2.2 OUTDOOR PHOTOELECTRIC SWITCHES

- A. Description: Solid state, with DPST dry contacts rated for 1000 W incandescent or 1800 VA inductive, to operate connected relay, contactor coils, or microprocessor input; complying with UL 773A, and compatible with ballasts and LED lamps.

1. Listed and labeled as defined in NFPA 70, by a qualified testing agency, and marked for intended location and application.
 2. Light-Level Monitoring Range: 1.5 to 10 fc, with an adjustment for turn-on and turn-off levels within that range, and a directional lens in front of the photocell to prevent fixed light sources from causing turn-off.
 3. Time Delay: Fifteen-second minimum, to prevent false operation.
 4. Surge Protection: Metal-oxide varistor.
 5. Mounting: Twist lock complies with NEMA C136.10, with base-and-stem mounting or stem-and-swivel mounting accessories as required to direct sensor to the north sky exposure.
 6. Failure Mode: Luminaire stays ON.
- B. Description: Solid state; one set of NO dry contacts rated for 24 V ac at 1 A to operate connected load, complying with UL 773, and compatible with luminaire and power pack.
1. Listed and labeled as defined in NFPA 70, by a qualified testing agency, and marked for intended location and application.
 2. Light-Level Monitoring Range: 1.5 to 10 fc, with an adjustment for turn-on and turn-off levels within that range.
 3. Time Delay: Thirty-second minimum, to prevent false operation.
 4. Mounting: 1/2-inch threaded male conduit.
 5. Failure Mode: Luminaire stays ON.
 6. Power Pack: Dry contacts rated for 20-A ballast or LED load at 120- and 277-V ac, for 13-A tungsten at 120-V ac, and for 1 hp at 120-V ac. Sensor has 24-V dc, 150-mA, Class 2 power source, as defined by NFPA 70.
 - a. LED status lights to indicate load status.
 - b. Plenum rated.
 7. Power Pack: Digital controller capable of accepting three RJ45 inputs with two outputs rated for 20-A incandescent or LED load at 120- and 277-V ac, for 13-A ballast or LED at 120- and 277-V ac, and for 1 hp at 120-V ac. Sensor has 24-V dc, Class 2 power source, as defined by NFPA 70.
 - a. With integral current monitoring
 - b. Compatible with digital addressable lighting interface.
 - c. Plenum rated.

2.3 INDOOR OCCUPANCY AND VACANCY SENSORS

A. General Requirements for Sensors:

1. Wall and Ceiling-mounted, solid-state indoor occupancy and vacancy sensors.
2. Dual technology.
3. Integrated power pack.
4. Hardwired connection to switch and lighting control system.
5. Listed and labeled as defined in NFPA 70, by a qualified testing agency, and marked for intended location and application.

6. Operation:
 - a. Occupancy Sensor: Unless otherwise indicated, turn lights on when coverage area is occupied, and turn them off when unoccupied; with a time delay for turning lights off, adjustable over a minimum range of 1 to 15 minutes.
 - b. Vacancy Sensor: Unless otherwise indicated, lights are manually turned on and sensor turns lights off when the room is unoccupied; with a time delay for turning lights off, adjustable over a minimum range of 1 to 15 minutes.
 - c. Combination Sensor: Unless otherwise indicated, sensor shall be programmed to turn lights on when coverage area is occupied and turn them off when unoccupied, or to turn off lights that have been manually turned on; with a time delay for turning lights off, adjustable over a minimum range of 1 to 15 minutes.
 7. Sensor Output: Contacts rated to operate the connected relay, complying with UL 773A. Sensor is powered from the power pack.
 8. Power: Line voltage.
 9. Power Pack: Dry contacts rated for 20-A ballast and LED load at 120- and 277-V ac, for 13-A tungsten at 120-V ac, and for 1hp at 120-V ac. Sensor has 24-V dc, 150-mA, Class 2 power source, as defined by NFPA 70.
 10. Mounting:
 - a. Sensor: Suitable for mounting in any position on a standard outlet box.
 - b. Relay: Externally mounted through a 1/2-inch knockout in a standard electrical enclosure.
 - c. Time-Delay and Sensitivity Adjustments: Recessed and concealed behind hinged door.
 11. Indicator: Digital display, to show when motion is detected during testing and normal operation of sensor.
 12. Bypass Switch: Override the "on" function in case of sensor failure.
 13. Automatic Light-Level Sensor: Adjustable from 2 to 200 fc; turn lights off when selected lighting level is present.
- B. PIR Type: Wall and Ceiling mounted; detect occupants in coverage area by their heat and movement.
1. Detector Sensitivity: Detect occurrences of 6-inch- minimum movement of any portion of a human body that presents a target of not less than 36 sq. in.
 2. Detection Coverage (Room, Ceiling Mounted): Detect occupancy anywhere in a circular area of 1000 sq. ft. when mounted on a 96-inch-high ceiling.
 3. Detection Coverage (Corridor, Ceiling Mounted): Detect occupancy within 90 feet when mounted on a 10-foot high ceiling.
 4. Detection Coverage (Room, Wall Mounted): Detect occupancy anywhere within a 180-degree pattern centered on the sensor over an area of 1000 square feet when mounted 48 inches above finished floor.
- C. Ultrasonic Type: Wall and Ceiling mounted; detect occupants in coverage area through pattern changes of reflected ultrasonic energy.

1. Detector Sensitivity: Detect a person of average size and weight moving not less than 12 inches in either a horizontal or a vertical manner at an approximate speed of 12 inches.
2. Detection Coverage (Small Room): Detect occupancy anywhere within a circular area of 600 sq. ft. when mounted on a 96-inch high ceiling.
3. Detection Coverage (Standard Room): Detect occupancy anywhere within a circular area of 1000 sq. ft. when mounted on a 96-inch-high ceiling.
4. Detection Coverage (Large Room): Detect occupancy anywhere within a circular area of 2000 sq. ft. when mounted on a 96-inch-high ceiling.
5. Detection Coverage (Corridor): Detect occupancy anywhere within 90 feet when mounted on a 10-foot high ceiling in a corridor not wider than 14 feet.
6. Detection Coverage (Room, Wall Mounted): Detect occupancy anywhere within a 180-degree pattern centered on the sensor over an area of 1000 square feet, 2000 square feet, and 3000 square feet when mounted 84 inches (2100 mm) above finished floor.

D. Dual-Technology Type: Wall and Ceiling mounted; detect occupants in coverage area using PIR and ultrasonic detection methods. The particular technology or combination of technologies that control on-off functions is selectable in the field by operating controls on unit.

1. Sensitivity Adjustment: Separate for each sensing technology.
2. Detector Sensitivity: Detect occurrences of 6-inch- minimum movement of any portion of a human body that presents a target of not less than 36 sq. in., and detect a person of average size and weight moving not less than 12 inches in either a horizontal or a vertical manner at an approximate speed of 12 inches/s.
3. Detection Coverage (Standard Room): Detect occupancy anywhere within a circular area of 1000 sq. ft. when mounted on a 96-inch-high ceiling.
4. Detection Coverage (Room, Wall Mounted): Detect occupancy anywhere within a 180-degree pattern centered on the sensor over an area of 1000 square feet when mounted 48 inches above finished floor.

2.4 SWITCHBOX-MOUNTED OCCUPANCY SENSORS

A. General Requirements for Sensors: Automatic-wall-switch occupancy sensor with manual on-off switch, suitable for mounting in a single gang switchbox, using hardwired connection.

1. Listed and labeled as defined in NFPA 70, by a qualified testing agency, and marked for intended location and application.
2. Occupancy Sensor Operation: Unless otherwise indicated, turn lights on when coverage area is occupied, and turn lights off when unoccupied; with a time delay for turning lights off, adjustable over a minimum range of 1 to 15 minutes.
3. Operating Ambient Conditions: Dry interior conditions, 32 to 120 deg F.
4. Switch Rating: Not less than, 1200-VA ballast or LED load at 277 V, and 800-W incandescent.

B. Wall-Switch Sensor Tag WS1:

1. Standard Range: 180-degree field of view, field adjustable from 180 to 40 degrees; with a minimum coverage area of 900 sq. ft..
2. Sensing Technology: Dual technology - PIR and ultrasonic.
3. Switch Type: SP, dual circuit. SP, field-selectable automatic "on," or manual "on," automatic "off."
4. Capable of controlling load in three-way application.
5. Voltage: Dual voltage - 120 and 277 V.
6. Ambient-Light Override: Concealed, field-adjustable, light-level sensor from 10 to 150 fc. The switch prevents the lights from turning on when the light level is higher than the set point of the sensor.
7. Concealed, field-adjustable, "off" time-delay selector at up to 30 minutes.
8. Concealed, "off" time-delay selector at 30 seconds and 5, 10, and 20 minutes.
9. Adaptive Technology: Self-adjusting circuitry detects and memorizes usage patterns of the space and helps eliminate false "off" switching.
10. Color: White.
11. Faceplate: Color matched to switch.

C. Wall-Switch Sensor Tag WS2:

1. Standard Range: 210-degree field of view, with a minimum coverage area of 900 sq. ft.
2. Sensing Technology: PIR.
3. Switch Type: SP, dual circuit. SP, field-selectable automatic "on," or manual "on," automatic "off."
4. Capable of controlling load in three-way application.
5. Voltage: Dual voltage, 120 and 277 V.
6. Ambient-Light Override: Concealed, field-adjustable, light-level sensor from 10 to 150 fc. The switch prevents the lights from turning on when the light level is higher than the set point of the sensor.
7. Concealed, field-adjustable, "off" time-delay selector at up to 30 minutes.
8. Concealed, "off" time-delay selector at 30 seconds and 5, 10, and 20 minutes.
9. Adaptive Technology: Self-adjusting circuitry detects and memorizes usage patterns of the space and helps eliminate false "off" switching.
10. Color: White.
11. Faceplate: Color matched to switch.

2.5 OUTDOOR MOTION SENSORS

A. General Requirements for Sensors: Solid-state outdoor motion sensors.

1. Listed and labeled as defined in NFPA 70, by a qualified testing agency, and marked for intended location and application.
2. Dual-technology (PIR and infrared) type, weatherproof. Detect occurrences of 6-inch- minimum movement of any portion of a human body that presents a target of not less than 36 sq. in.. Comply with UL 773A.
3. Switch Rating:
 - a. Luminaire-Mounted Sensor: 1000-W incandescent, 500-VA fluorescent/LED.

- b. Separately Mounted Sensor: Dry contacts rated for 20-A ballast load at 120- and 277-V ac, for 13-A tungsten at 120-V ac, and for 1 hp at 120-V ac. Sensor has 24-V dc, 150-mA, Class 2 power source, as defined by NFPA 70.
- 4. Switch Type: SP, dual circuit. SP, field-selectable automatic "on," or manual "on," automatic "off." With bypass switch to override the "on" function in case of sensor failure.
- 5. Voltage: Dual voltage, 120- and 277-V type.
- 6. Detector Coverage:
 - a. Standard Range: 210-degree field of view, with a minimum coverage area of 900 sq. ft..
 - b. Long Range: 180-degree field of view and 110-foot detection range.
- 7. Ambient-Light Override: Concealed, field-adjustable, light-level sensor from 10 to 150 fc (108 to 1600 lux). The switch prevents the lights from turning on when the light level is higher than the set point of the sensor.
- 8. Concealed, field-adjustable, "off" time-delay selector at up to 30 minutes.
- 9. Concealed, "off" time-delay selector at 30 seconds and 5, 10, and 20 minutes.
- 10. Adaptive Technology: Self-adjusting circuitry detects and memorizes usage patterns of the space and help eliminate false "off" switching.
- 11. Operating Ambient Conditions: Suitable for operation in ambient temperatures ranging from minus 40 to plus 130 deg F, rated as "raintight" according to UL 773A.

2.6 LIGHTING CONTACTORS

- A. Description: Electrically operated and mechanically held, combination-type lighting contactors with non-fused disconnect, complying with NEMA ICS 2 and UL 508.
 - 1. Current Rating for Switching: Listing or rating consistent with type of load served, including tungsten filament, inductive, and high-inrush ballast (ballast with 15 percent or less THD of normal load current).
 - 2. Fault Current Withstand Rating: Equal to or exceeding the available fault current at the point of installation.
 - 3. Enclosure: Comply with NEMA 250.
 - 4. Provide with control and pilot devices as indicated on Drawings, matching the NEMA type specified for the enclosure.

2.7 CONDUCTORS AND CABLES

- A. Power Wiring to Supply Side of Remote-Control Power Sources: Not smaller than No. 12 AWG. Comply with requirements in Section 16120 "Low-Voltage Electrical Power Conductors and Cables."
- B. Classes 2 and 3 Control Cable: Multiconductor cable with stranded-copper conductors not smaller than No. 18 AWG. Comply with requirements in Section 16120 "Low-Voltage Electrical Power Conductors and Cables."

- C. Class 1 Control Cable: Multiconductor cable with stranded-copper conductors not smaller than No. 14 AWG. Comply with requirements in Section 16120 "Low-Voltage Electrical Power Conductors and Cables."

PART 3 - EXECUTION

3.1 INSTALLATION

- A. Comply with NECA 1.
- B. Examine lighting control devices before installation. Reject lighting control devices that are wet, moisture damaged, or mold damaged.
- C. Coordinate layout and installation of ceiling-mounted devices with other construction that penetrates ceilings or is supported by them, including light fixtures, HVAC equipment, smoke detectors, fire-suppression systems, and partition assemblies.
- D. Install and aim sensors in locations to achieve not less than 90-percent coverage of areas indicated. Do not exceed coverage limits specified in manufacturer's written instructions.
- E. Mount electrically held lighting contactors with elastomeric isolator pads to eliminate structure-borne vibration unless contactors are installed in an enclosure with factory-installed vibration isolators.

3.2 WIRING INSTALLATION

- A. Wiring Method: Comply with Section 16120 "Low-Voltage Electrical Power Conductors and Cables." Minimum conduit size is 3/4" inch.
- B. Wiring within Enclosures: Separate power-limited and nonpower-limited conductors according to conductor manufacturer's written instructions.
- C. Size conductors according to lighting control device manufacturer's written instructions unless otherwise indicated.
- D. Splices, Taps, and Terminations: Make connections only on numbered terminal strips in junction, pull, and outlet boxes; terminal cabinets; and equipment enclosures.

3.3 IDENTIFICATION

- A. Identify components and power and control wiring according to Section 16052 "Identification for Electrical Systems."
- B. Label time switches and contactors with a unique designation.

3.4 FIELD QUALITY CONTROL

- A. Perform the following tests and inspections with the assistance of a factory-authorized service representative:
 - 1. Operational Test: After installing time switches and sensors, and after electrical circuitry has been energized, start units to confirm proper unit operation.
 - 2. Test and adjust controls and safeties. Replace damaged and malfunctioning controls and equipment.
- B. Lighting control devices will be considered defective if they do not pass tests and inspections.
- C. Prepare test and inspection reports.

3.5 ADJUSTING

- A. Occupancy Adjustments: When requested within 12 months from date of Substantial Completion, provide on-site assistance in adjusting lighting control devices to suit actual occupied conditions. Provide up to two visits to Project during other-than-normal occupancy hours for this purpose.
 - 1. For occupancy and motion sensors, verify operation at outer limits of detector range. Set time delay to suit Owner's operations.
 - 2. For daylighting controls, adjust set points and deadband controls to suit Owner's operations.

3.6 SOFTWARE SERVICE AGREEMENT

- A. Technical Support: Beginning at Substantial Completion, service agreement shall include software support for two years.
- B. Upgrade Service: At Substantial Completion, update software to latest version. Install and program software upgrades that become available within two years from date of Substantial Completion. Upgrading software shall include operating system and new or revised licenses for using software.
 - 1. Upgrade Notice: At least 30 days to allow Owner to schedule and access the system and to upgrade computer equipment if necessary.

3.7 DEMONSTRATION

- A. Engage a factory-authorized service representative to train Owner's maintenance personnel to adjust, operate, and maintain lighting control devices.

END OF SECTION

SECTION 16520

LED EXTERIOR LIGHTING

PART 1 - GENERAL

1.1 SUMMARY

A. Section Includes:

1. Exterior solid-state luminaires that are designed for and exclusively use LED lamp technology.
2. Luminaire supports.
3. Luminaire-mounted photoelectric relays.

B. Related Requirements:

1. Section 16512 "Lighting Control Devices" for automatic control of lighting, including time switches, photoelectric relays, occupancy sensors, and multipole lighting relays and contactors.

1.2 DEFINITIONS

- A. CCT: Correlated color temperature.
- B. CRI: Color rendering index.
- C. Fixture: See "Luminaire."
- D. IP: International Protection or Ingress Protection Rating
- E. Lumen: Measured output of lamp and luminaire, or both.
- F. Luminaire: Complete lighting unit, including lamp, reflector, and housing.

1.3 ACTION SUBMITTALS

- A. Product Data: For each type of luminaire.
- B. Shop Drawings: For nonstandard or custom luminaires.
 1. Include plans, elevations, sections, and mounting and attachment details.
 2. Include details of luminaire assemblies. Indicate dimensions, weights, loads, required clearances, method of field assembly, components, and location and size of each field connection.
 3. Include diagrams for power, signal, and control wiring.
- C. Delegated-Design Submittal: For luminaire supports.

1. Include design calculations for luminaire supports and seismic restraints.

1.4 INFORMATIONAL SUBMITTALS

- A. Coordination Drawings: Plans, drawn to scale and coordinated.
- B. Seismic Qualification Certificates: For luminaires, accessories, and components, from manufacturer.
- C. Product Certificates: For each type of the following:
 1. Luminaire.
 2. Photoelectric relay.
- D. Sample warranty.

1.5 CLOSEOUT SUBMITTALS

- A. Operation and maintenance data.
 1. Provide a list of all lamp types used on Project. Use ANSI and manufacturers' codes.
 2. Provide a list of all photoelectric relay types used on Project; use manufacturers' codes.

1.6 FIELD CONDITIONS

- A. Mark locations of exterior luminaires for approval by Architect prior to the start of luminaire installation.

1.7 WARRANTY

- A. Warranty: Manufacturer and Installer agree to repair or replace components of luminaires that fail in materials or workmanship within specified warranty period.
 1. Warranty Period: 2 year(s) from date of Substantial Completion.

PART 2 - PRODUCTS

2.1 PERFORMANCE REQUIREMENTS

- A. Seismic Performance: Luminaires shall withstand the effects of earthquake motions determined according to ASCE/SEI 7.
- B. Seismic Performance: Luminaires and lamps shall be labeled vibration and shock resistant.

1. The term "withstand" means "the luminaire will remain in place without separation of any parts when subjected to the seismic forces specified and the luminaire will be fully operational during and after the seismic event."

2.2 LUMINAIRE REQUIREMENTS

- A. Electrical Components, Devices, and Accessories: Listed and labeled as defined in NFPA 70, by a qualified testing agency, and marked for intended location and application.
- B. NRTL Compliance: Luminaires shall be listed and labeled for indicated class and division of hazard by an NRTL.
- C. FM Global Compliance: Luminaires for hazardous locations shall be listed and labeled for indicated class and division of hazard by FM Global.
- D. UL Compliance: Comply with UL 1598 and listed for wet location.
- E. Lamp base complying with ANSI C81.61 or IEC 60061-1.
- F. CRI of minimum 65. CCT of 3000 K.
- G. L70 lamp life of 50,000 hours.
- H. Lamps dimmable from 100 percent to 0 percent of maximum light output.
- I. Nominal Operating Voltage: 120 V ac /277 V ac.
- J. In-line Fusing: Separate in-line fuse for each luminaire.
- K. Lamp Rating: Lamp marked for outdoor use and in enclosed locations.
- L. Source Limitations: Obtain luminaires from single source from a single manufacturer.
- M. Source Limitations: For luminaires, obtain each color, grade, finish, type, and variety of luminaire from single source with resources to provide products of consistent quality in appearance and physical properties.

2.3 LUMINAIRE TYPES

- A. Area and Site:
 1. Luminaire Shape: Refer to Lighting Fixture Schedule in contract documents.
 2. Mounting: Pole and Building, refer to Lighting Fixture Schedule in contract documents.
 3. Luminaire-Mounting Height: Refer to Lighting Fixture Schedule in contract documents.
 4. Distribution: Refer to Lighting Fixture Schedule in contract documents.

2.4 MATERIALS

- A. Metal Parts: Free of burrs and sharp corners and edges.
- B. Sheet Metal Components: Stainless steel. Form and support to prevent warping and sagging.
- C. Doors, Frames, and Other Internal Access: Smooth operating, free of light leakage under operating conditions, and designed to permit relamping without use of tools. Designed to prevent doors, frames, lenses, diffusers, and other components from falling accidentally during relamping and when secured in operating position. Doors shall be removable for cleaning or replacing lenses.
- D. Diffusers and Globes:
 - 1. Acrylic Diffusers: 100 percent virgin acrylic plastic, with high resistance to yellowing and other changes due to aging, exposure to heat, and UV radiation.
 - 2. Glass: Annealed crystal glass unless otherwise indicated.
 - 3. Lens Thickness: At least 0.125 inch minimum unless otherwise indicated.
- E. Lens and Refractor Gaskets: Use heat- and aging-resistant resilient gaskets to seal and cushion lenses and refractors in luminaire doors.
- F. Reflecting surfaces shall have minimum reflectance as follows unless otherwise indicated:
 - 1. White Surfaces: 85 percent.
 - 2. Specular Surfaces: 83 percent.
 - 3. Diffusing Specular Surfaces: 75 percent.
- G. Housings:
 - 1. Rigidly formed, weather- and light-tight enclosure that will not warp, sag, or deform in use.
 - 2. Provide filter/breather for enclosed luminaires.

2.5 FINISHES

- A. Variations in Finishes: Noticeable variations in same piece are unacceptable. Variations in appearance of adjoining components are acceptable if they are within the range of approved Samples and are assembled or installed to minimize contrast.
- B. Luminaire Finish: Manufacturer's standard paint applied to factory-assembled and -tested luminaire before shipping. Where indicated, match finish process and color of pole or support materials.
- C. Factory-Applied Finish for Aluminum Luminaires: Comply with NAAMM's "Metal Finishes Manual for Architectural and Metal Products" for recommendations for applying and designating finishes.

2.6 LUMINAIRE SUPPORT COMPONENTS

- A. Comply with requirements in Section 16050 "Hangers and Supports for Electrical Systems" for channel and angle iron supports and nonmetallic channel and angle supports.

PART 3 - EXECUTION

3.1 GENERAL INSTALLATION REQUIREMENTS

- A. Comply with NECA 1.
- B. Use fastening methods and materials selected to resist seismic forces defined for the application and approved by manufacturer.
- C. Install lamps in each luminaire.
- D. Fasten luminaire to structural support.
- E. Supports:
 - 1. Sized and rated for luminaire weight.
 - 2. Able to maintain luminaire position after cleaning and relamping.
 - 3. Support luminaires without causing deflection of finished surface.
 - 4. Luminaire-mounting devices shall be capable of supporting a horizontal force of 100 percent of luminaire weight and a vertical force of 400 percent of luminaire weight.
- F. Wiring Method: Install cables in raceways. Conceal raceways and cables.
- G. Install luminaires level, plumb, and square with finished grade unless otherwise indicated. Install luminaires at height and aiming angle as indicated on Drawings.
- H. Coordinate layout and installation of luminaires with other construction.
- I. Adjust luminaires that require field adjustment or aiming. Include adjustment of photoelectric device to prevent false operation of relay by artificial light sources, favoring a north orientation.
- J. Comply with requirements in Section 16120 "Low-Voltage Electrical Power Conductors and Cables" and 16110 "Raceways and Boxes for Electrical Systems" for wiring connections and wiring methods.

3.2 INSTALLATION OF INDIVIDUAL GROUND-MOUNTED LUMINAIRES

- A. Aim as indicated on Drawings.
- B. Install on concrete base with top 4 inches above finished grade or surface at luminaire location. Cast conduit into base, and finish by troweling and rubbing smooth. Concrete

materials, installation, and finishing are specified in Section 03300 "Cast-in-Place Concrete."

3.3 CORROSION PREVENTION

- A. Aluminum: Do not use in contact with earth or concrete. When in direct contact with a dissimilar metal, protect aluminum by insulating fittings or treatment.
- B. Steel Conduits: Comply with Section 16110 "Raceways and Boxes for Electrical Systems." In concrete foundations, wrap conduit with 0.010-inch thick, pipe-wrapping plastic tape applied with a 50 percent overlap.

3.4 IDENTIFICATION

- A. Identify system components, wiring, cabling, and terminals. Comply with requirements for identification specified in Section 16052 "Identification for Electrical Systems."

3.5 FIELD QUALITY CONTROL

- A. Inspect each installed luminaire for damage. Replace damaged luminaires and components.
- B. Perform the following tests and inspections with the assistance of a factory-authorized service representative:
 - 1. Operational Test: After installing luminaires, switches, and accessories, and after electrical circuitry has been energized, test units to confirm proper operation.
 - 2. Verify operation of photoelectric controls.
- C. Illumination Tests:
 - 1. Measure light intensities at night. Use photometers with calibration referenced to NIST standards. Comply with the following IES testing guide(s):
 - a. IES LM-5.
 - b. IES LM-50.
 - c. IES LM-52.
 - d. IES LM-64.
 - e. IES LM-72.
 - 2. Operational Test: After installing luminaires, switches, and accessories, and after electrical circuitry has been energized, test units to confirm proper operation.
- D. Luminaire will be considered defective if it does not pass tests and inspections.
- E. Prepare a written report of tests, inspections, observations, and verifications indicating and interpreting results. If adjustments are made to lighting system, retest to demonstrate compliance with standards.

3.6 DEMONSTRATION

- A. Train Owner's maintenance personnel to adjust, operate, and maintain luminaires and photocell relays.

END OF SECTION

SECTION 16601

LIGHTNING PROTECTION FOR STRUCTURES

PART 1 - GENERAL

1.1 SUMMARY

A. Section includes lightning protection system for the following:

1. Ordinary structures.

1.2 ACTION SUBMITTALS

A. Product Data: For each type of product.

B. Shop Drawings:

1. Include layouts of the lightning protection system, with details of the components to be used in the installation.
2. Include raceway locations needed for the installation of conductors.
3. Details of air terminals, ground rods, ground rings, conductor supports, splices, and terminations, including concealment requirements.
4. Calculations required by NFPA 780 for bonding of metal bodies.

1.3 INFORMATIONAL SUBMITTALS

A. Coordination Drawings: Lightning protection system Shop Drawings, drawn to scale, coordinated with each other, using input from installers of the items involved:

B. Qualification Data: For Installer.

C. Product certificates.

D. Field quality-control reports.

1.4 CLOSEOUT SUBMITTALS

A. Maintenance data.

B. Completion Certificate:

1. UL Master Label Certificate.

1.5 QUALITY ASSURANCE

A. Installer Qualifications: UL-listed installer, category OWAY or LPI Master Installer.

PART 2 - PRODUCTS

2.1 PERFORMANCE REQUIREMENTS

- A. NFPA Lightning Protection Standard: Comply with NFPA 780 requirements for Class I buildings.
- B. UL Lightning Protection Standard: Comply with UL 96A requirements for Class I buildings.
- C. Lightning Protection Components, Devices, and Accessories: Listed and labeled by a qualified testing agency as complying with UL 96, and marked for intended location and application.

2.2 MATERIALS

- A. Air Terminals:
 - 1. Copper or Aluminum unless otherwise indicated.
 - 2. 1/2-inch diameter by 12 inches long.
 - 3. Pointed tip.
 - 4. Integral base support.
- B. Class 1 Main Conductors: Stranded Copper: 57,400 circular mils in diameter.
 - 1. Aluminum: 98,600 circular mils in diameter.
- C. Class II Main Conductors:
 - 1. Stranded Copper: 115,000 circular mils in diameter.
 - 2. Aluminum: 192,000 circular mils in diameter.
- D. Secondary Conductors:
 - 1. Stranded Copper: 26,240 circular mils in diameter.
 - 2. Aluminum: 41,400 circular mils in diameter.
- E. Ground Loop Conductor: Stranded copper.
- F. Ground Rods:
 - 1. Material: Solid copper.
 - 2. Diameter: 3/4 inch.
 - 3. Rods shall be not less than 10 feet long.

PART 3 - EXECUTION

3.1 INSTALLATION

- A. Install lightning protection components and systems according to UL 96A and NFPA 780.
- B. Install conductors with direct paths from air terminals to ground connections. Avoid bends less than 90 degrees and 8 inches in radius and narrow loops.
- C. Conceal conductors within normal view from exterior locations at grade within 200 feet of building. Comply with requirements for concealed installations in UL 96A and concealed systems in NFPA 780.
- D. Ground Ring Electrode: The conductor shall be not less than the main-size lightning conductor.

3.2 CONNECTIONS

- A. Aboveground concealed connections, and connections in earth or concrete, shall be done by exothermic welds or by high-compression fittings listed for the purpose.
- B. Aboveground exposed connections shall be done using the following types of connectors, listed and labeled for the purpose: bolted connectors.
- C. Bonding Straps and Jumpers: Install in locations accessible for inspection and maintenance, except where routed through short lengths of conduit.
 - 1. Bonding to Structure: Bond straps directly to basic structure, taking care not to penetrate any adjacent parts.
 - 2. Bonding to Equipment Mounted on Vibration Isolation Hangers and Supports: Install bonding so vibration is not transmitted to rigidly mounted equipment.

3.3 FIELD QUALITY CONTROL

- A. Special Inspections: Engage a qualified special inspector to perform the following special inspections:
 - 1. Perform inspections as required to obtain a UL Master Label for system.
 - 2. Perform inspections to obtain an LPI certification.
- B. Prepare test and inspection reports and certificates.

END OF SECTION

SECTION 16621ENGINE GENERATORS

PART 1 - GENERAL

1.1 SUMMARY

- A. Section includes packaged engine-generator sets for emergency power supply with the following features:
 - 1. Diesel engine.
 - 2. Unit-mounted cooling system.
 - 3. Unit-mounted control and monitoring.
 - 4. Performance requirements for sensitive loads.
 - 5. Outdoor sound-attenuated enclosure.
 - 6. Access stairs and platforms.
 - 7. Sub base fuel tank.
- B. Related Requirements:
 - 1. Section 16410 "Transfer Switches" for transfer switches including sensors and relays to initiate automatic-starting and -stopping signals for engine-generator sets.

1.2 ACTION SUBMITTALS

- A. Product Data: For each type of product.
- B. Shop Drawings:
 - 1. Include plans and elevations for engine-generator set and other components specified. Indicate access requirements affected by height of subbase fuel tank.
 - 2. Include details of equipment assemblies. Indicate dimensions, weights, loads, and required clearances, method of field assembly, components, and location and size of each field connection.

1.3 INFORMATIONAL SUBMITTALS

- A. Qualification Data: For manufacturer.
- B. Seismic Qualification Certificates: For engine-generator set, accessories, and components, from manufacturer.
 - 1. Basis for Certification: Indicate whether withstand certification is based on actual test of assembled components or on calculation.
 - 2. Dimensioned Outline Drawings of Equipment Unit: With engine and generator mounted on rails identify center of gravity and total weight, supplied enclosure,

- external silencer, and each piece of equipment not integral to the engine-generator set, and locate and describe mounting and anchorage provisions.
 - 3. Detailed description of equipment anchorage devices on which the certification is based and their installation requirements.
- C. Source quality-control reports, including, but not limited to the following:
- 1. Certified summary of prototype-unit test report.
 - 2. Certified Test Reports: For components and accessories that are equivalent, but not identical, to those tested on prototype unit.
 - 3. Report of factory test on units to be shipped for this Project, showing evidence of compliance with specified requirements.
 - 4. Report of sound generation.
 - 5. Report of exhaust emissions showing compliance with applicable regulations.
 - 6. Certified Torsional Vibration Compatibility: Comply with NFPA 110.
- D. Field quality-control reports.
- E. Warranty: For special warranty.
- 1.4 CLOSEOUT SUBMITTALS
- A. Operation and maintenance data.
- 1.5 QUALITY ASSURANCE
- A. Testing Agency Qualifications: Member company of NETA or an NRTL.
 - 1. Testing Agency's Field Supervisor: Certified by NETA to supervise on-site testing.
- 1.6 WARRANTY
- A. Manufacturer's Warranty: Manufacturer agrees to repair or replace components of packaged engine generators and associated auxiliary components that fail in materials or workmanship within specified warranty period.
 - 1. Warranty Period: Five years from date of Substantial Completion.

PART 2 - PRODUCTS

2.1 MANUFACTURERS

- A. Source Limitations: Obtain packaged generator sets and auxiliary components through one source from a single manufacturer.

- B. Subject to compliance with requirements, provide diesel generator set from one of the following manufacturers:
1. Caterpillar.
 2. Cummins Power Generation.
 3. Kohler Power Systems.
 4. Or Engineer approved equivalent.

2.2 PERFORMANCE REQUIREMENTS

- A. Seismic Performance: Engine-generator set housing, engine-generator set, batteries, battery racks, silencers, and sound attenuating equipment, accessories, and components shall withstand the effects of earthquake motions determined according to ASCE/SEI 7.
1. The term "withstand" means "the unit will remain in place without separation of any parts when subjected to the seismic forces specified and the unit will be fully operational after the seismic event."
 2. Shake-table testing shall comply with ICC-ES AC156. Testing shall be performed with all fluids at worst case normal levels.
 3. Component Importance Factor: 1.5.
- B. ASME Compliance: Comply with ASME B15.1.
- C. NFPA Compliance:
1. Comply with NFPA 37.
 2. Comply with NFPA 70.
 3. Comply with NFPA 99.
 4. Comply with NFPA 110 requirements for Level 1 emergency power supply system.
- D. UL Compliance: Comply with UL 2200.
- E. Engine Exhaust Emissions: Comply with EPA Tier 4 requirements and applicable state and local government requirements.
- F. Noise Emission: Comply with applicable state and local government requirements for maximum noise level at due to sound emitted by generator set including engine, engine exhaust, engine cooling-air intake and discharge, and other components of installation.
- G. Environmental Conditions: Engine-generator system shall withstand the following environmental conditions without mechanical or electrical damage or degradation of performance capability:
1. Ambient Temperature: 5 to 40 deg C.
 2. Relative Humidity: Zero to 95 percent.
 3. Altitude: Sea level to 1000 feet.

2.3 ASSEMBLY DESCRIPTION

- A. Factory-assembled and -tested, water-cooled engine, with brushless generator and accessories.
- B. Electrical Components, Devices, and Accessories: Listed and labeled as defined in NFPA 70, by a testing agency acceptable to authorities having jurisdiction, and marked for intended location and application.
- C. EPSS Class: Engine-generator set shall be classified as a Class 2 in accordance with NFPA 110.
- D. Governor: Adjustable isochronous, with speed sensing.
- E. Emissions: Comply with EPA Tier 4 requirements.
- F. Mounting Frame: Structural steel framework to maintain alignment of mounted components without depending on concrete foundation. Provide lifting attachments sized and spaced to prevent deflection of base during lifting and moving.
- G. Capacities and Characteristics:
 - 1. Power Output Ratings: Nominal ratings as indicated at 0.8 power factor excluding power required for the continued and repeated operation of the unit and auxiliaries, with capacity as required to operate as a unit as evidenced by records of prototype testing.
 - 2. Output Connections: Three-phase, four wire.
 - 3. Nameplates: For each major system component to identify manufacturer's name and address, and model and serial number of component.
- H. Generator-Set Performance:
 - 1. Steady-State Voltage Operational Bandwidth: 3 percent of rated output voltage from no load to full load.
 - 2. Transient Voltage Performance: Not more than 20 percent variation for 50 percent step-load increase or decrease. Voltage shall recover and remain within the steady-state operating band within three seconds.
 - 3. Steady-State Frequency Operational Bandwidth: 0.5 percent of rated frequency from no load to full load.
 - 4. Steady-State Frequency Stability: When system is operating at any constant load within the rated load, there shall be no random speed variations outside the steady-state operational band and no hunting or surging of speed.
 - 5. Transient Frequency Performance: Less than 5 percent variation for 50 percent step-load increase or decrease. Frequency shall recover and remain within the steady-state operating band within five seconds.
 - 6. Output Waveform: At no load, harmonic content measured line to line or line to neutral shall not exceed 5 percent total and 3 percent for single harmonics. Telephone influence factor, determined according to NEMA MG 1, shall not exceed 50 percent.

7. Sustained Short-Circuit Current: For a three-phase, bolted short circuit at system output terminals, system shall supply a minimum of 250 percent of rated full-load current for not less than 10 seconds and then clear the fault automatically, without damage to generator system components.
8. Start Time: Comply with NFPA 110, Type 10, system requirements.

2.4 ENGINE

- A. Fuel: diesel.
- B. Rated Engine Speed: 1800 rpm.
- C. Maximum Piston Speed for Four-Cycle Engines: 2250 fpm.
- D. Lubrication System: The following items are mounted on engine or skid:
 1. Filter and Strainer: Rated to remove 90 percent of particles 5 micrometers and smaller while passing full flow.
 2. Thermostatic Control Valve: Control flow in system to maintain optimum oil temperature. Unit shall be capable of full flow and is designed to be fail-safe.
 3. Crankcase Drain: Arranged for complete gravity drainage to an easily removable container with no disassembly and without use of pumps, siphons, special tools, or appliances.
- E. Jacket Coolant Heater: Electric-immersion type, factory installed in coolant jacket system. Comply with NFPA 110 requirements for Level 1 equipment for heater capacity.
- F. Cooling System: Closed loop, liquid cooled, with radiator factory mounted on engine-generator-set mounting frame and integral engine-driven coolant pump.
 1. Coolant: Solution of 50 percent ethylene-glycol-based antifreeze and 50 percent water, with anticorrosion additives as recommended by engine manufacturer.
 2. Size of Radiator: Adequate to contain expansion of total system coolant from cold start to 110 percent load condition.
 3. Expansion Tank: Constructed of welded steel plate and rated to withstand maximum closed-loop coolant system pressure for engine used. Equip with gage glass and petcock.
 4. Temperature Control: Self-contained, thermostatic-control valve modulates coolant flow automatically to maintain optimum constant coolant temperature as recommended by engine manufacturer.
- G. Muffler/Silencer: Semicritical type, sized as recommended by engine manufacturer and selected with exhaust piping system to not exceed engine manufacturer's engine backpressure requirements.
 1. Minimum sound attenuation of 18 dB at 500 Hz.
 2. Sound level measured at a distance of 25 feet from exhaust discharge after installation is complete shall be 85 dBA or less.

- H. Air-Intake Filter: Heavy-duty, engine-mounted air cleaner with replaceable dry-filter element and "blocked filter" indicator.
- I. Starting System: 12-V electric, with negative ground.
 - 1. Components: Sized so they are not damaged during a full engine-cranking cycle with ambient temperature at maximum specified in "Performance Requirements" Article.
 - 2. Cranking Motor: Heavy-duty unit that automatically engages and releases from engine flywheel without binding.
 - 3. Cranking Cycle: As required by NFPA 110 for system level specified.
 - 4. Battery: Lead acid, with capacity within ambient temperature range specified in "Performance Requirements" Article to provide specified cranking cycle at least twice without recharging.
 - 5. Battery Stand: Factory-fabricated, two-tier metal with acid-resistant finish designed to hold the quantity of battery cells required and to maintain the arrangement to minimize lengths of battery interconnections.
 - 6. Battery Charger: Current-limiting, automatic-equalizing and float-charging type designed for lead-acid batteries. Unit shall comply with UL 1236.

2.5 FUEL SYSTEM

- A. Fuel injected
 - 1. Primary and secondary fuel filters.
 - 2. Fuel priming pump.

2.6 CONTROL AND MONITORING

- A. Automatic Starting System Sequence of Operation: When mode-selector switch on the control and monitoring panel is in the automatic position, remote-control contacts in one or more separate automatic transfer switches initiate starting and stopping of generator set. When mode-selector switch is switched to the on position, generator set starts. The off position of same switch initiates generator-set shutdown. When generator set is running, specified system or equipment failures or derangements automatically shut down generator set and initiate alarms.
- B. Provide minimum run time control set for 15 minutes with override only by operation of an emergency-stop switch.
- C. Comply with UL 508A.
- D. Configuration: Operating and safety indications, protective devices, basic system controls, and engine gages shall be grouped in a common control and monitoring panel mounted on the generator set. Mounting method shall isolate the control panel from generator-set vibration. Panel shall be powered from the engine-generator set battery.

- E. Configuration: Operating and safety indications, protective devices, basic system controls, and engine gages shall be grouped in a common wall-mounted control and monitoring panel. Panel shall be powered from the engine-generator set battery.
1. Wall-Mounting Cabinet Construction: Rigid, self-supporting steel unit complying with NEMA ICS 6. Power bus shall be copper. Bus, bus supports, control wiring, and temperature rise shall comply with UL 891.
- F. Indicating Devices: As required by NFPA 110 for Level 1 system, including the following:
1. AC voltmeter.
 2. AC ammeter.
 3. AC frequency meter.
 4. EPS supplying load indicator.
 5. Ammeter and voltmeter phase-selector switches.
 6. DC voltmeter (alternator battery charging).
 7. Engine-coolant temperature gage.
 8. Engine lubricating-oil pressure gage.
 9. Running-time meter.
 10. Current and Potential Transformers: Instrument accuracy class.
- G. Protective Devices and Controls in Local Control Panel: Shutdown devices and common visual alarm indication as required by NFPA 110 for Level 1 system, including the following:
1. Start-stop switch.
 2. Overcrank shutdown device.
 3. Overspeed shutdown device.
 4. Coolant high-temperature shutdown device.
 5. Coolant low-level shutdown device.
 6. Low lube oil pressure shutdown device.
 7. Air shutdown damper shutdown device when used.
 8. Overcrank alarm.
 9. Overspeed alarm.
 10. Coolant high-temperature alarm.
 11. Coolant low-temperature alarm.
 12. Coolant low-level alarm.
 13. Low lube oil pressure alarm.
 14. Air shutdown damper alarm when used.
 15. Lamp test.
 16. Contacts for local common alarm.
 17. Coolant high-temperature prealarm.
 18. Generator-voltage adjusting rheostat.
 19. Run-Off-Auto switch.
 20. Control switch not in automatic position alarm.
 21. Low cranking voltage alarm.
 22. Battery-charger malfunction alarm.
 23. Battery low-voltage alarm.
 24. Battery high-voltage alarm.

25. Generator overcurrent protective device not closed alarm.

- H. Supporting Items: Include sensors, transducers, terminals, relays, and other devices and include wiring required to support specified items. Locate sensors and other supporting items on engine or generator, unless otherwise indicated.
- I. Supporting Items: Include sensors, transducers, terminals, relays, and other devices and include wiring required to support specified items. Locate sensors and other supporting items on engine or generator, unless otherwise indicated.

2.7 GENERATOR OVERCURRENT AND FAULT PROTECTION

- A. Overcurrent protective devices for the entire EPSS shall be coordinated to optimize selective tripping when a short circuit occurs. Coordination of protective devices shall consider both utility and EPSS as the voltage source.
 - 1. Overcurrent protective devices for the EPSS shall be accessible only to authorized personnel.
- B. Generator Circuit Breaker: Molded-case, electronic-trip type; 100 percent rated; complying with UL 489.
 - 1. Tripping Characteristics: Adjustable long-time and short-time delay and instantaneous.
 - 2. Trip Settings: Selected to coordinate with generator thermal damage curve.
 - 3. Shunt Trip: Connected to trip breaker when generator set is shut down by other protective devices.
 - 4. Mounting: Adjacent to or integrated with control and monitoring panel.
- C. Ground-Fault Indication: Comply with NFPA 70, "Emergency System" signals for ground fault.
 - 1. Indicate ground fault with other generator-set alarm indications.
 - 2. Trip generator protective device on ground fault.

2.8 GENERATOR, EXCITER, AND VOLTAGE REGULATOR

- A. Comply with NEMA MG 1.
- B. Drive: Generator shaft shall be directly connected to engine shaft. Exciter shall be rotated integrally with generator rotor.
- C. Electrical Insulation: Class H or Class F.
- D. Stator-Winding Leads: Brought out to terminal box to permit future reconnection for other voltages if required. Provide six lead alternator.
- E. Range: Provide broad range of output voltage by adjusting the excitation level.

- F. Construction shall prevent mechanical, electrical, and thermal damage due to vibration, overspeed up to 125 percent of rating, and heat during operation at 110 percent of rated capacity.
- G. Enclosure: Dripproof.
- H. Instrument Transformers: Mounted within generator enclosure.
- I. Voltage Regulator: Solid-state type, separate from exciter, providing performance as specified and as required by NFPA 110.
 - 1. Adjusting Rheostat on Control and Monitoring Panel: Provide plus or minus 5 percent adjustment of output-voltage operating band.
- J. Strip Heater: Thermostatically controlled unit arranged to maintain stator windings above dew point.
- K. Windings: Two-thirds pitch stator winding and fully linked amortisseur winding.
- L. Subtransient Reactance: 12 percent, maximum.

2.9 OUTDOOR GENERATOR-SET ENCLOSURE

- A. Description: Vandal-resistant, sound-attenuating, weatherproof steel housing, wind resistant up to 100 mph. Multiple panels shall be lockable and provide adequate access to components requiring maintenance. Panels shall be removable by one person without tools. Instruments and control shall be mounted within enclosure.
- B. Engine Cooling Airflow through Enclosure: Maintain temperature rise of system components within required limits when unit operates at 110 percent of rated load for 2 hours with ambient temperature at top of range specified in system service conditions.
 - 1. Louvers: Fixed-engine, cooling-air inlet and discharge. Storm-proof and drainable louvers prevent entry of rain and snow.
 - 2. Automatic Dampers: At engine cooling-air inlet and discharge. Dampers shall be closed to reduce enclosure heat loss in cold weather when unit is not operating.
 - 3. Ventilation: Provide temperature-controlled exhaust fan interlocked to prevent operation when engine is running.
- C. Interior Lights with Switch: Factory-wired, vapor-proof fixtures within housing; arranged to illuminate controls and accessible interior. Arrange for external electrical connection.
 - 1. AC lighting system and connection point for operation when remote source is available.
 - 2. DC lighting system for operation when remote source and generator are both unavailable.
- D. Convenience Outlets: Factory wired, GFCI. Arrange for external electrical connection.

2.10 VIBRATION ISOLATION DEVICES

- A. Elastomeric Isolator Pads: Oil- and water-resistant elastomer or natural rubber, arranged in single or multiple layers, molded with a nonslip pattern and galvanized-steel baseplates of sufficient stiffness for uniform loading over pad area, and factory cut to sizes that match requirements of supported equipment.
 - 1. Material: Standard neoprene separated by steel shims.
 - 2. Shore "A" Scale Durometer Rating: 30.
 - 3. Number of Layers: One.
 - 4. Minimum Deflection: 1 inch.
- B. Comply with requirements in Section 15185 "Hydronic Piping Specialties" for vibration isolation and flexible connectors materials for steel piping.
- C. Vibration isolation devices shall not be used to accommodate misalignments or to make bends.

2.11 FINISHES

- A. Indoor and Outdoor Enclosures and Components: Manufacturer's standard finish over corrosion-resistant pretreatment and compatible primer.

2.12 SOURCE QUALITY CONTROL

- A. Prototype Testing: Factory test engine-generator set using same engine model, constructed of identical or equivalent components and equipped with identical or equivalent accessories.
 - 1. Tests: Comply with NFPA 110, Level 1 Energy Converters and with IEEE 115.

PART 3 - EXECUTION

3.1 INSTALLATION

- A. Comply with packaged engine-generator manufacturers' written installation and alignment instructions and with NFPA 110.
- B. Equipment Mounting:
 - 1. Install packaged engine generators on cast-in-place concrete equipment bases. Comply with requirements for equipment bases and foundations specified in Section 03300 "Cast-in-Place Concrete."
 - 2. Coordinate size and location of concrete bases for packaged engine generators. Cast anchor-bolt inserts into bases. Concrete, reinforcement, and formwork requirements are specified with concrete.

- C. Install packaged engine-generator to provide access, without removing connections or accessories, for periodic maintenance.
- D. Install packaged engine-generator with elastomeric isolator pads having a minimum deflection of 1 inch on 4-inch high concrete base. Secure sets to anchor bolts installed in concrete bases.
- E. Install Schedule 40, black steel piping with welded joints and connect to engine muffler. Install thimble at wall. Piping shall be same diameter as muffler outlet.
 - 1. Install flexible connectors and steel piping materials according to requirements in Section 15185 Hydronic Piping Specialties."
 - 2. Insulate muffler/silencer and exhaust system components according to requirements in Section 15250 "HVAC Piping Insulation."
 - 3. Install isolating thimbles where exhaust piping penetrates combustible surfaces with a minimum of 9 inches clearance from combustibles.
- F. Install condensate drain piping to muffler drain outlet full size of drain connection with a shutoff valve, stainless-steel flexible connector, and Schedule 40, black steel pipe with welded joints.
- G. Electrical Wiring: Install electrical devices furnished by equipment manufacturers but not specified to be factory mounted.

3.2 CONNECTIONS

- A. Connect cooling-system water piping to engine-generator set and heat exchanger with flexible connectors.
- B. Connect engine exhaust pipe to engine with flexible connector.
- C. Ground equipment according to Section 16450 "Grounding and Bonding for Electrical Systems."
- D. Connect wiring according to Section 16120 "Low-Voltage Electrical Power Conductors and Cables." Provide a minimum of one 90 degree bend in flexible conduit routed to the generator set from a stationary element.
- E. Balance single-phase loads to obtain a maximum of 10 percent unbalance between any two phases.

3.3 IDENTIFICATION

- A. Identify system components according to Section 16052 "Identification for Electrical Systems."
- B. Install a sign indicating the generator neutral is bonded to the main service neutral at the main service location.

3.4 FIELD QUALITY CONTROL

A. Perform tests and inspections.

1. Manufacturer's Field Service: Engage a factory-authorized service representative to inspect components, assemblies, and equipment installations, including connections.

B. Tests and Inspections:

1. Perform tests recommended by manufacturer and each visual and mechanical inspection and electrical and mechanical test listed in the first two subparagraphs as specified in NETA Acceptance Testing Specification. Certify compliance with test parameters.
 - a. Visual and Mechanical Inspection
 - 1) Compare equipment nameplate data with drawings and specifications.
 - 2) Inspect physical and mechanical condition.
 - 3) Inspect anchorage, alignment, and grounding.
 - 4) Verify the unit is clean.
 - b. Electrical and Mechanical Tests
 - 1) Perform insulation-resistance tests in accordance with IEEE 43.
 - a) Machines 200 horsepower or less. Test duration shall be one minute. Calculate the dielectric-absorption ratio.
 - 2) Test protective relay devices.
 - 3) Verify phase rotation, phasing, and synchronized operation as required by the application.
 - 4) Functionally test engine shutdown for low oil pressure, over temperature, over speed, and other protection features as applicable.
 - 5) Conduct performance test in accordance with NFPA 110.
 - 6) Verify correct functioning of the governor and regulator.
2. NFPA 110 Acceptance Tests: Perform tests required by NFPA 110 that are additional to those specified here including, but not limited to, single-step full-load pickup test.
3. Battery Tests: Equalize charging of battery cells according to manufacturer's written instructions. Record individual cell voltages.
 - a. Measure charging voltage and voltages between available battery terminals for full-charging and float-charging conditions. Check electrolyte level and specific gravity under both conditions.
 - b. Test for contact integrity of all connectors. Perform an integrity load test and a capacity load test for the battery.
 - c. Verify acceptance of charge for each element of the battery after discharge.
 - d. Verify that measurements are within manufacturer's specifications.

4. Battery-Charger Tests: Verify specified rates of charge for both equalizing and float-charging conditions.
 5. System Integrity Tests: Methodically verify proper installation, connection, and integrity of each element of engine-generator system before and during system operation. Check for air, exhaust, and fluid leaks.
 6. Exhaust-System Back-Pressure Test: Use a manometer with a scale exceeding 40-inch wg. Connect to exhaust line close to engine exhaust manifold. Verify that back pressure at full-rated load is within manufacturer's written allowable limits for the engine.
 7. Exhaust Emissions Test: Comply with applicable government test criteria.
 8. Voltage and Frequency Transient Stability Tests: Use recording oscilloscope to measure voltage and frequency transients for 50 and 100 percent step-load increases and decreases, and verify that performance is as specified.
 9. Harmonic-Content Tests: Measure harmonic content of output voltage at 25 percent and 100 percent of rated linear load. Verify that harmonic content is within specified limits.
- C. Coordinate tests with tests for transfer switches and run them concurrently.
- D. Test instruments shall have been calibrated within the last 12 months, traceable to NIST Calibration Services, and adequate for making positive observation of test results. Make calibration records available for examination on request.
- E. Leak Test: After installation, charge exhaust, coolant, and fuel systems and test for leaks. Repair leaks and retest until no leaks exist.
- F. Operational Test: After electrical circuitry has been energized, start units to confirm proper motor rotation and unit operation for generator and associated equipment.
- G. Test and adjust controls and safeties. Replace damaged and malfunctioning controls and equipment.
- H. Remove and replace malfunctioning units and retest as specified above.
- I. Retest: Correct deficiencies identified by tests and observations and retest until specified requirements are met.
- J. Report results of tests and inspections in writing. Record adjustable relay settings and measured insulation resistances, time delays, and other values and observations. Attach a label or tag to each tested component indicating satisfactory completion of tests.
- 3.5 DEMONSTRATION
- A. Engage a factory-authorized service representative to train Owner's maintenance personnel to adjust, operate, and maintain packaged engine generators.

END OF SECTION

SECTION 16723DIGITAL, ADDRESSABLE FIRE-ALARM SYSTEM

PART 1 - GENERAL

1.1 SUMMARY

A. Section Includes:

1. Fire-alarm control unit.
2. Manual fire-alarm boxes.
3. System smoke detectors.
4. Heat detectors.
5. Notification appliances.
6. Remote annunciator.
7. Addressable interface device.
8. Digital alarm communicator transmitter.

B. Related Requirements:

1. Section 16800 "Telecommunications Cabling" for cables and conductors for fire-alarm systems.

1.2 ACTION SUBMITTALS

A. Product Data: For each type of product, including furnished options and accessories.

B. Shop Drawings: For fire-alarm system.

1. Comply with recommendations and requirements in the "Documentation" section of the "Fundamentals" chapter in NFPA 72.
2. Include plans, elevations, sections, details, and attachments to other work.
3. Include details of equipment assemblies. Indicate dimensions, weights, loads, required clearances, method of field assembly, components, and locations. Indicate conductor sizes, indicate termination locations and requirements, and distinguish between factory and field wiring.
4. Detail assembly and support requirements.
5. Include voltage drop calculations for notification-appliance circuits.
6. Include battery-size calculations.
7. Include input/output matrix.
8. Include statement from manufacturer that all equipment and components have been tested as a system and meet all requirements in this Specification and in NFPA 72.
9. Include performance parameters and installation details for each detector.
10. Verify that each duct detector is listed for complete range of air velocity, temperature, and humidity possible when air-handling system is operating.

11. Include plans, sections, and elevations of heating, ventilating, and air-conditioning ducts, drawn to scale; coordinate location of duct smoke detectors and access to them.
 - a. Show critical dimensions that relate to placement and support of sampling tubes, detector housing, and remote status and alarm indicators.
 - b. Show field wiring required for HVAC unit shutdown on alarm.
 - c. Locate detectors according to manufacturer's written recommendations.
12. Include floor plans to indicate final outlet locations showing address of each addressable device. Show size and route of cable and conduits and point-to-point wiring diagrams.

C. General Submittal Requirements:

1. Submittals shall be approved by authorities having jurisdiction prior to submitting them to Architect.
2. Shop Drawings shall be prepared by persons with the following qualifications:
 - a. Trained and certified by manufacturer in fire-alarm system design.
 - b. NICET-certified, fire-alarm technician; Level III minimum.
 - c. Licensed or certified by authorities having jurisdiction.

D. Delegated-Design Submittal: For notification appliances and smoke and heat detectors, in addition to submittals listed above, indicate compliance with performance requirements and design criteria, including analysis data signed and sealed by the qualified professional engineer responsible for their preparation.

1. Drawings showing the location of each notification appliance and smoke and heat detector, ratings of each, and installation details as needed to comply with listing conditions of the device.
2. Design Calculations: Calculate requirements for selecting the spacing and sensitivity of detection, complying with NFPA 72. Calculate spacing and intensities for strobe signals and sound-pressure levels for audible appliances.
3. Indicate audible appliances required to produce square wave signal per NFPA 72.

1.3 INFORMATIONAL SUBMITTALS

- A. Qualification Data: For Installer.
- B. Seismic Qualification Certificates: For fire-alarm control unit, accessories, and components, from manufacturer.
- C. Field quality-control reports.
- D. Sample warranty.

1.4 CLOSEOUT SUBMITTALS

A. Operation and Maintenance Data: For fire-alarm systems and components to include in emergency, operation, and maintenance manuals.

1. Include the following and deliver copies to authorities having jurisdiction:
 - a. Comply with the "Records" section of the "Inspection, Testing and Maintenance" chapter in NFPA 72.
 - b. Provide "Fire Alarm and Emergency Communications System Record of Completion Documents" according to the "Completion Documents" Article in the "Documentation" section of the "Fundamentals" chapter in NFPA 72.
 - c. Complete wiring diagrams showing connections between all devices and equipment.
 - d. Riser diagram.
 - e. Record copy of site-specific software.
 - f. Provide "Inspection and Testing Form" according to the "Inspection, Testing and Maintenance" chapter in NFPA 72, and include the following:
 - 1) Equipment tested.
 - 2) Frequency of testing of installed components.
 - 3) Frequency of inspection of installed components.
 - 4) Requirements and recommendations related to results of maintenance.
 - 5) Manufacturer's user training manuals.
 - g. Manufacturer's required maintenance related to system warranty requirements.
 - h. Abbreviated operating instructions for mounting at fire-alarm control unit and each annunciator unit.

B. Software and Firmware Operational Documentation:

1. Software operating and upgrade manuals.
2. Program Software Backup: On magnetic media or compact disk, complete with data files.
3. Device address list.
4. Printout of software application and graphic screens.

1.5 QUALITY ASSURANCE

A. Installer Qualifications: Personnel shall be trained and certified by manufacturer for installation of units required for this Project.

B. Installer Qualifications: Installation shall be by personnel certified by NICET as fire-alarm Level III technician.

C. NFPA Certification: Obtain certification according to NFPA 72 by an NRTL (nationally recognized testing laboratory).

- D. NFPA Certification: Obtain certification according to NFPA 72 by a UL-listed alarm company.
- E. NFPA Certification: Obtain certification according to NFPA 72 in the form of a placard by an FM Global-approved alarm company.
- F. NFPA Certification: Obtain certification according to NFPA 72 by.

1.6 WARRANTY

- A. Special Warranty: Manufacturer agrees to repair or replace fire-alarm system equipment and components that fail in materials or workmanship within specified warranty period.
 - 1. Warranty Extent: All equipment and components not covered in the Maintenance Service Agreement.
 - 2. Warranty Period: Five years from date of Substantial Completion.

PART 2 - PRODUCTS

2.1 SYSTEM DESCRIPTION

- A. Source Limitations for Fire-Alarm System and Components: Components shall be compatible with, and operate as an extension of, existing system. Provide system manufacturer's certification that all components provided have been tested as, and will operate as, a system.
- B. Noncoded, UL-certified FM and Global-placarded addressable system, with multiplexed signal transmission and horn/strobe evacuation.
- C. Automatic sensitivity control of certain smoke detectors.
- D. All components provided shall be listed for use with the selected system.
- E. Electrical Components, Devices, and Accessories: Listed and labeled as defined in NFPA 70, by a qualified testing agency, and marked for intended location and application.

2.2 SYSTEMS OPERATIONAL DESCRIPTION

- A. Fire-alarm signal initiation shall be by one or more of the following devices and systems:
 - 1. Manual stations.
 - 2. Heat detectors.
 - 3. Smoke detectors.
 - 4. Duct smoke detectors.
 - 5. Fire-extinguishing system operation.

- B. Fire-alarm signal shall initiate the following actions:
1. Continuously operate alarm notification appliances.
 2. Identify alarm and specific initiating device at fire-alarm control unit and remote annunciators.
 3. Transmit an alarm signal to the remote alarm receiving station.
 4. Unlock electric door locks in designated egress paths.
 5. Switch heating, ventilating, and air-conditioning equipment controls to fire-alarm mode.
 6. Close smoke dampers in air ducts of designated air-conditioning duct systems.
 7. Activate emergency shutoffs for gas and fuel supplies.
 8. Record events in the system memory.
- C. System trouble signal initiation shall be by one or more of the following devices and actions:
1. Open circuits, shorts, and grounds in designated circuits.
 2. Loss of communication with any addressable sensor, input module, relay, control module, or remote annunciator.
 3. Loss of primary power at fire-alarm control unit.
 4. Ground or a single break in internal circuits of fire-alarm control unit.
 5. Abnormal ac voltage at fire-alarm control unit.
 6. Break in standby battery circuitry.
 7. Failure of battery charging.
 8. Abnormal position of any switch at fire-alarm control unit or annunciator.
- D. System Supervisory Signal Actions:
1. Initiate notification appliances.
 2. Identify specific device initiating the event at fire-alarm control unit and remote annunciators.
 3. After a time delay of 200 seconds, transmit a trouble or supervisory signal to the remote alarm receiving station.

2.3 PERFORMANCE REQUIREMENTS

- A. Seismic Performance: Fire-alarm control unit and raceways shall withstand the effects of earthquake motions determined according to ASCE/SEI 7.
1. The term "withstand" means "the unit will remain in place without separation of any parts from the device when subjected to the seismic forces specified and the unit will be fully operational after the seismic event."

2.4 FIRE-ALARM CONTROL UNIT

- A. General Requirements for Fire-Alarm Control Unit:
1. Field-programmable, microprocessor-based, modular, power-limited design with electronic modules, complying with UL 864.

2. Addressable Initiation Device Circuits: The FACP shall indicate which communication zones have been silenced and shall provide selective silencing of alarm notification appliance by building communication zone.
 3. Addressable Control Circuits for Operation of Notification Appliances and Mechanical Equipment: The FACP shall be listed for releasing service.
- B. Alphanumeric Display and System Controls: Arranged for interface between human operator at fire-alarm control unit and addressable system components including annunciation and supervision. Display alarm, supervisory, and component status messages and the programming and control menu.
1. Annunciator and Display: Liquid-crystal type, 80 characters, minimum.
 2. Keypad: Arranged to permit entry and execution of programming, display, and control commands.
- C. Initiating-Device, Notification-Appliance, and Signaling-Line Circuits:
1. Pathway Class Designations: NFPA 72, Class B.
 2. Pathway Survivability: Level 0.
- D. Notification-Appliance Circuit:
1. Audible appliances shall sound in a three-pulse temporal pattern, as defined in NFPA 72.
 2. Where notification appliances provide signals to sleeping areas, the alarm signal shall be a 520-Hz square wave with an intensity 15 dB above the average ambient sound level or 5 dB above the maximum sound level, or at least 75 dBA, whichever is greater, measured at the pillow.
 3. Visual alarm appliances shall flash in synchronization where multiple appliances are in the same field of view, as defined in NFPA 72.
- E. Door Controls: Door hold-open devices that are controlled by smoke detectors at doors in smoke-barrier walls shall not be connected to fire-alarm system.
- F. Remote Smoke-Detector Sensitivity Adjustment: Controls shall select specific addressable smoke detectors for adjustment, display their current status and sensitivity settings, and change those settings. Allow controls to be used to program repetitive, time-scheduled, and automated changes in sensitivity of specific detector groups. Record sensitivity adjustments and sensitivity-adjustment schedule changes in system memory.
- G. Transmission to Remote Alarm Receiving Station: Automatically transmit alarm, supervisory, and trouble signals to a remote alarm station.
- H. Primary Power: 24-V dc obtained from 120-V ac service and a power-supply module. Initiating devices, notification appliances, signaling lines, trouble signals, supervisory and digital alarm communicator transmitters and digital alarm radio transmitters shall be powered by 24-V dc source.
1. Alarm current draw of entire fire-alarm system shall not exceed 80 percent of the power-supply module rating.

- I. Secondary Power: 24-V dc supply system with batteries, automatic battery charger, and automatic transfer switch.

2.5 MANUAL FIRE-ALARM BOXES

- A. General Requirements for Manual Fire-Alarm Boxes: Comply with UL 38.
 1. Single-action mechanism, pull-lever type; with integral addressable module arranged to communicate manual-station status (normal, alarm, or trouble) to fire-alarm control unit.
 2. Station Reset: Key- or wrench-operated switch.

2.6 SYSTEM SMOKE DETECTORS

- A. General Requirements for System Smoke Detectors:
 1. Comply with UL 268; operating at 24-V dc, nominal.
 2. Detectors shall be four-wire type.
 3. Integral Addressable Module: Arranged to communicate detector status (normal, alarm, or trouble) to fire-alarm control unit.
 4. Base Mounting: Detector and associated electronic components shall be mounted in a twist-lock module that connects to a fixed base. Provide terminals in the fixed base for connection to building wiring.
 5. Self-Restoring: Detectors do not require resetting or readjustment after actuation to restore them to normal operation.
 6. Integral Visual-Indicating Light: LED type, indicating detector has operated and power-on status.
 7. Remote Control: Unless otherwise indicated, detectors shall be digital-addressable type, individually monitored at fire-alarm control unit for calibration, sensitivity, and alarm condition and individually adjustable for sensitivity by fire-alarm control unit.
 8. Retain first two subparagraphs below only for combination smoke- and heat-detection units. Fixed-temperature sensing characteristic of combination smoke- and heat-detection units shall be independent of rate-of-rise sensing and shall be settable at fire-alarm control unit to operate at 135 or 155 deg F.
 - a. Multiple levels of detection sensitivity for each sensor.
 - b. Sensitivity levels based on time of day.
- B. Photoelectric Smoke Detectors:
 1. Detector address shall be accessible from fire-alarm control unit and shall be able to identify the detector's location within the system and its sensitivity setting.
 2. An operator at fire-alarm control unit, having the designated access level, shall be able to manually access the following for each detector:
 - a. Primary status.
 - b. Device type.
 - c. Present average value.
 - d. Present sensitivity selected.

- e. Sensor range (normal, dirty, etc.).

C. Ionization Smoke Detector:

1. Detector address shall be accessible from fire-alarm control unit and shall be able to identify the detector's location within the system and its sensitivity setting.
2. An operator at fire-alarm control unit, having the designated access level, shall be able to manually access the following for each detector:
 - a. Primary status.
 - b. Device type.
 - c. Present average value.
 - d. Present sensitivity selected.
 - e. Sensor range (normal, dirty, etc.).

D. Duct Smoke Detectors: Photoelectric type complying with UL 268A.

1. Detector address shall be accessible from fire-alarm control unit and shall be able to identify the detector's location within the system and its sensitivity setting.
2. An operator at fire-alarm control unit, having the designated access level, shall be able to manually access the following for each detector:
 - a. Primary status.
 - b. Device type.
 - c. Present average value.
 - d. Present sensitivity selected.
 - e. Sensor range (normal, dirty, etc.).
3. Weatherproof Duct Housing Enclosure: NEMA 250, Type 4X; NRTL listed for use with the supplied detector for smoke detection in HVAC system ducts.
4. Each sensor shall have multiple levels of detection sensitivity.
5. Sampling Tubes: Design and dimensions as recommended by manufacturer for specific duct size, air velocity, and installation conditions where applied.
6. Relay Fan Shutdown: Fully programmable relay rated to interrupt fan motor-control circuit.

2.7 HEAT DETECTORS

A. General Requirements for Heat Detectors: Comply with UL 521.

1. Temperature sensors shall test for and communicate the sensitivity range of the device.

B. Heat Detector, Combination Type: Actuated by either a fixed temperature or a rate of rise.

1. Mounting: Twist-lock base interchangeable with smoke-detector bases.
2. Integral Addressable Module: Arranged to communicate detector status (normal, alarm, or trouble) to fire-alarm control unit.

- C. Heat Detector, Fixed-Temperature Type: Actuated by temperature that exceeds a fixed temperature.
 - 1. Mounting: Twist-lock base interchangeable with smoke-detector bases.
 - 2. Integral Addressable Module: Arranged to communicate detector status (normal, alarm, or trouble) to fire-alarm control unit.

2.8 NOTIFICATION APPLIANCES

- A. General Requirements for Notification Appliances: Connected to notification-appliance signal circuits, zoned as indicated, equipped for mounting as indicated, and with screw terminals for system connections.
 - 1. Combination Devices: Factory-integrated audible and visible devices in a single-mounting assembly, equipped for mounting as indicated, and with screw terminals for system connections.
- B. Chimes: Vibrating type.
- C. Horns: Electric-vibrating-polarized type, 24-V dc; with provision for housing the operating mechanism behind a grille. Comply with UL 464.
- D. Visible Notification Appliances: Xenon strobe lights complying with UL 1971, with clear or nominal white polycarbonate lens mounted on an aluminum faceplate. The word "FIRE" is engraved in minimum 1-inch high letters on the lens.
 - 1. Mounting: Wall mounted unless otherwise indicated.
 - 2. Flashing shall be in a temporal pattern, synchronized with other units.
 - 3. Strobe Leads: Factory connected to screw terminals.
 - 4. Mounting Faceplate: Factory finished, red.

2.9 REMOTE ANNUNCIATOR

- A. Description: Annunciator functions shall match those of fire-alarm control unit for alarm, supervisory, and trouble indications. Manual switching functions shall match those of fire-alarm control unit, including acknowledging, silencing, resetting, and testing.
 - 1. Mounting: As indicated in Contract Documents, NEMA 250, Type 1.
- B. Display Type and Functional Performance: Alphanumeric display and LED indicating lights shall match those of fire-alarm control unit. Provide controls to acknowledge, silence, reset, and test functions for alarm, supervisory, and trouble signals.

2.10 ADDRESSABLE INTERFACE DEVICE

- A. General:

1. Include address-setting means on the module.
 2. Store an internal identifying code for control panel use to identify the module type.
 3. Listed for controlling HVAC fan motor controllers.
- B. Monitor Module: Microelectronic module providing a system address for alarm-initiating devices for wired applications with normally open contacts.
- C. Integral Relay: Capable of providing a direct signal to elevator controller to initiate elevator recall and to circuit-breaker shunt trip for power shutdown.
1. Allow the control panel to switch the relay contacts on command.
 2. Have a minimum of two normally open and two normally closed contacts available for field wiring.
- D. Control Module:
1. Operate notification devices.
 2. Operate solenoids for use in sprinkler service.

2.11 DIGITAL ALARM COMMUNICATOR TRANSMITTER

- A. Digital alarm communicator transmitter shall be acceptable to the remote central station and shall comply with UL 632.
- B. Functional Performance: Unit shall receive an alarm, supervisory, or trouble signal from fire-alarm control unit and automatically capture one telephone line(s) and dial a preset number for a remote central station. When contact is made with central station(s), signals shall be transmitted. If service on either line is interrupted for longer than 45 seconds, transmitter shall initiate a local trouble signal and transmit the signal indicating loss of telephone line to the remote alarm receiving station over the remaining line. Transmitter shall automatically report telephone service restoration to the central station. If service is lost on both telephone lines, transmitter shall initiate the local trouble signal.
- C. Local functions and display at the digital alarm communicator transmitter shall include the following:
1. Verification that both telephone lines are available.
 2. Programming device.
 3. LED display.
 4. Manual test report function and manual transmission clear indication.
 5. Communications failure with the central station or fire-alarm control unit.
- D. Digital data transmission shall include the following:
1. Address of the alarm-initiating device.
 2. Address of the supervisory signal.
 3. Address of the trouble-initiating device.
 4. Loss of ac supply.

5. Loss of power.
 6. Low battery.
 7. Abnormal test signal.
 8. Communication bus failure.
- E. Secondary Power: Integral rechargeable battery and automatic charger.
- F. Self-Test: Conducted automatically every 24 hours with report transmitted to central station.

PART 3 - EXECUTION

3.1 EQUIPMENT INSTALLATION

- A. Comply with NFPA 72, NFPA 101, and requirements of authorities having jurisdiction for installation and testing of fire-alarm equipment. Install all electrical wiring to comply with requirements in NFPA 70 including, but not limited to, Article 760, "Fire Alarm Systems."
- B. Connecting to Existing Equipment: Verify that existing fire-alarm system is operational before making changes or connections.
- C. Equipment Mounting: Install fire-alarm control unit on wall.
- D. Install wall-mounted equipment, with tops of cabinets not more than 78 inches above the finished floor.
- E. Manual Fire-Alarm Boxes:
 1. Install manual fire-alarm box in the normal path of egress within 60 inches of the exit doorway.
 2. Mount manual fire-alarm box on a background of a contrasting color.
 3. The operable part of manual fire-alarm box shall be between 42 inches and 48 inches above floor level. All devices shall be mounted at the same height unless otherwise indicated.
- F. Smoke- or Heat-Detector Spacing: Comply with NFPA 72.
- G. Duct Smoke Detectors: Comply with NFPA 72 and NFPA 90A. Install sampling tubes so they extend the full width of duct. Tubes more than 36 inches long shall be supported at both ends.
- H. Elevator Shafts: Coordinate temperature rating and location with sprinkler rating and location. Do not install smoke detectors in sprinklered elevator shafts.
- I. Single-Station Smoke Detectors: Where more than one smoke alarm is installed within a dwelling or suite, they shall be connected so that the operation of any smoke alarm causes the alarm in all smoke alarms to sound.

- J. Remote Status and Alarm Indicators: Install in a visible location near each smoke detector, sprinkler water-flow switch, and valve-tamper switch that is not readily visible from normal viewing position.
- K. Audible Alarm-Indicating Devices: Install not less than 6 inches below the ceiling. Install bells and horns on flush-mounted back boxes with the device-operating mechanism concealed behind a grille. Install all devices at the same height unless otherwise indicated.
- L. Visible Alarm-Indicating Devices: Install adjacent to each alarm bell or alarm horn and at least 6 inches below the ceiling. Install all devices at the same height unless otherwise indicated.
- M. Device Location-Indicating Lights: Locate in public space near the device they monitor.

3.2 PATHWAYS

- A. Pathways above recessed ceilings and in non-accessible locations may be routed exposed.
 1. Exposed pathways located less than 96 inches above the floor shall be installed in EMT.
- B. Pathways shall be installed in EMT.
- C. Exposed EMT shall be painted red enamel.

3.3 CONNECTIONS

- A. For fire-protection systems related to doors in fire-rated walls and partitions and to doors in smoke partitions, comply with requirements in Section 08110 "Steel Doors and Frames." Connect hardware and devices to fire-alarm system.
 1. Verify that hardware and devices are listed for use with installed fire-alarm system before making connections.
- B. Make addressable connections with a supervised interface device to the following devices and systems. Install the interface device less than 36 inches from the device controlled. Make an addressable confirmation connection when such feedback is available at the device or system being controlled.
 1. Smoke dampers in air ducts of designated HVAC duct systems.
 2. Magnetically held-open doors.
 3. Electronically locked doors and access gates.
 4. Alarm-initiating connection to elevator recall system and components.
 5. Alarm-initiating connection to activate emergency lighting control.
 6. Alarm-initiating connection to activate emergency shutoffs for gas and fuel supplies.
 7. Supervisory connections at valve supervisory switches.

8. Supervisory connections at low-air-pressure switch of each dry-pipe sprinkler system.
9. Supervisory connections at fire-extinguisher locations.
10. Generator run status.

3.4 IDENTIFICATION

- A. Identify system components, wiring, cabling, and terminals. Comply with requirements for identification specified in Section 16052 "Identification for Electrical Systems."
- B. Install framed instructions in a location visible from fire-alarm control unit.

3.5 GROUNDING

- A. Ground fire-alarm control unit and associated circuits; comply with IEEE 1100. Install a ground wire from main service ground to fire-alarm control unit.
- B. Ground shielded cables at the control panel location only. Insulate shield at device location.

3.6 FIELD QUALITY CONTROL

- A. Field tests shall be witnessed by authorities having jurisdiction.
- B. Perform the following tests and inspections with the assistance of a factory-authorized service representative:
 1. Visual Inspection: Conduct visual inspection prior to testing.
 - a. Inspection shall be based on completed record Drawings and system documentation that is required by NFPA 72 in its "Completion Documents, Preparation" table in the "Documentation" section of the "Fundamentals" chapter.
 - b. Comply with the "Visual Inspection Frequencies" table in the "Inspection" section of the "Inspection, Testing and Maintenance" chapter in NFPA 72; retain the "Initial/Reacceptance" column and list only the installed components.
 2. System Testing: Comply with the "Test Methods" table in the "Testing" section of the "Inspection, Testing and Maintenance" chapter in NFPA 72.
 3. Test audible appliances for the public operating mode according to manufacturer's written instructions. Perform the test using a portable sound-level meter complying with Type 2 requirements in ANSI S1.4.
 4. Test audible appliances for the private operating mode according to manufacturer's written instructions.
 5. Test visible appliances for the public operating mode according to manufacturer's written instructions.

6. Factory-authorized service representative shall prepare the "Fire Alarm System Record of Completion" in the "Documentation" section of the "Fundamentals" chapter in NFPA 72 and the "Inspection and Testing Form" in the "Records" section of the "Inspection, Testing and Maintenance" chapter in NFPA 72.
- C. Reacceptance Testing: Perform reacceptance testing to verify the proper operation of added or replaced devices and appliances.
- D. Fire-alarm system will be considered defective if it does not pass tests and inspections.
- E. Prepare test and inspection reports.
- F. Maintenance Test and Inspection: Perform tests and inspections listed for weekly, monthly, quarterly, and semiannual periods. Use forms developed for initial tests and inspections.
- G. Annual Test and Inspection: One year after date of Substantial Completion, test fire-alarm system complying with visual and testing inspection requirements in NFPA 72. Use forms developed for initial tests and inspections.

3.7 SOFTWARE SERVICE AGREEMENT

- A. Comply with UL 864.
- B. Technical Support: Beginning at Substantial Completion, service agreement shall include software support for two years.
- C. Upgrade Service: At Substantial Completion, update software to latest version. Install and program software upgrades that become available within two years from date of Substantial Completion. Upgrading software shall include operating system and new or revised licenses for using software.
 1. Upgrade Notice: At least 30 days to allow Owner to schedule access to system and to upgrade computer equipment if necessary.

3.8 DEMONSTRATION

- A. Train Owner's maintenance personnel to adjust, operate, and maintain fire-alarm system.

END OF SECTION

SECTION 16800

TELECOMMUNICATIONS CABLING

PART 1 - GENERAL

1.1 SUMMARY

A. Section Includes:

1. Unshielded Twisted Pair (UTP) Cable.
2. Coaxial Cable.
3. Fiber Optic Cable.
4. Cable Hardware.
5. Telecommunications Outlet/Connectors.

B. Related Requirements:

1. Section 16825 "Telecommunications Equipment"

1.2 ACTION SUBMITTALS

- A. As-Built Drawings. Submit prior to final acceptance of the work, drawings showing complete layout of systems installed including physical location of ground rods to which connections were made.
- B. Field Quality Control Test Report. Submit reports complying with requirements of Part 3 "Field Quality Control" Article.

1.3 DEFINITIONS

- A. BICSI: Building Industry Consulting Service International.
- B. Cross-Connect: A facility enabling the termination of cable elements and their interconnection or cross-connection.
- C. EMI: Electromagnetic interference.
- D. IDC: Insulation displacement connector.
- E. LAN: Local area network.
- F. Outlet/Connectors: A connecting device in the work area on which horizontal cable or outlet cable terminates.
- G. RCDD: Registered Communications Distribution Designer.
- H. UTP: Unshielded twisted pair.

PART 2 - PRODUCTS

2.1 HORIZONTAL CABLING DESCRIPTION

- A. Horizontal cable and its connecting hardware provide the means of transporting signals between the telecommunications outlet/connector and the horizontal cross-connect located in the MTA Communications Room (Room 001A). This cabling and its connecting hardware are called a "permanent link," a term that is used in the testing protocols.
 - 1. TIA-568-C.1 requires that a minimum of two telecommunications outlet/connectors be installed for each work area.
 - 2. Horizontal cabling shall contain no more than one transition point or consolidation point between the horizontal cross-connect and the telecommunications outlet/connector.
 - 3. Bridged taps and splices shall not be installed in the horizontal cabling.
- B. A work area includes the components that extend from the telecommunications outlet/connectors to the local equipment.
- C. The maximum allowable horizontal cable length for Category 6A cable is 295 feet (90 m). This maximum allowable length does not include an allowance for the length of 16 feet (4.9 m) to the workstation equipment or in the horizontal cross-connect.

2.2 PERFORMANCE REQUIREMENTS

- A. General Performance: Horizontal cabling system shall comply with transmission standards in TIA-568-C.1 when tested according to test procedures of this standard.
- B. Surface-Burning Characteristics: Comply with ASTM E 84; testing by a qualified testing agency. Identify products with appropriate markings of applicable testing agency.
 - 1. Flame-Spread Index: 25 or less.
 - 2. Smoke-Developed Index: 50 or less.
- C. Electrical Components, Devices, and Accessories: Listed and labeled as defined in NFPA 70, by a qualified testing agency, and marked for intended location and application.
- D. Grounding: Comply with J-STD-607-A.

2.3 UTP CABLE

- A. Manufacturers: Subject to compliance with requirements, available manufacturers offering products that may be incorporated into the Work include, but are not limited to, the following:

1. ADC.
 2. Belden Inc.
 3. General Cable
 4. Mohawk; a division of Belden Networking, Inc.
 5. Superior Essex Inc.
- B. Description: 100-ohm, Category 6A, #23 AWG solid copper, unshielded twisted pair (UTP) cabling as indicated on drawings, formed into 4-pair binder groups, with a core and pair separator, covered with a thermoplastic jacket.
- C. Listed and labeled by an NRTL acceptable to authorities having jurisdiction as complying with UL 444 and NFPA 70 for the following types:
1. Communications, Plenum Rated: Type CMP, complying with NFPA 262.

2.4 UTP CABLE HARDWARE

- A. Manufacturers: Subject to compliance with requirements, available manufacturers offering products that may be incorporated into the Work include, but are not limited to, the following:
1. ADC.
 2. American Technology Systems Industries, Inc.
 3. Belden Inc.
 4. Hubbell Premise Wiring.
 5. Leviton Commercial Networks Division.
 6. Legrand, Ortronics
 7. Molex Premise Networks; a division of Molex, Inc.
 8. Panduit Corp.
- B. General Requirements for Cable Connecting Hardware: Comply with TIA-568-C.2, IDC type, with modules designed for punch-down caps or tools. Cables shall be terminated with connecting hardware of same category or higher.
- C. Connecting Blocks: 110-style IDC for Category 6A. Provide blocks for the number of cables terminated on the block, plus 25 percent spare. Integral with connector bodies, including plugs and jacks where indicated.
1. Number of Terminals per Field: One for each conductor in assigned cables.
- D. Patch Panel: Modular, blank, keystone-type patch panels housing multiple-numbered spaces for jack units for installation of snap-in keystone jacks.
1. Number of Jacks per Field: One for each four-pair UTP cable indicated, plus spares and blank positions adequate to suit specified expansion criteria.
- E. Jacks and Jack Assemblies: Modular, keystone snap-in, color-coded, Category 6A, eight-position receptacle units with integral IDC-type terminals.

1. Jacks shall be terminated according to T568B standard.

F. Patch Cords: Factory-made, Category 6A patch cables, in the following quantities and lengths:

1. Fifty (50) – 2-meter lengths – Blue.
2. Fifty (50) – 2-meter lengths – Green.

2.5 COAXIAL CABLE

A. Manufacturers: Subject to compliance with requirements, acceptable manufacturers offering products that may be incorporated into the Work include, but are not limited to, the following:

1. Alpha Wire Company.
2. Belden CDT Inc.; Electronics Division.
3. Coleman Cable, Inc.
4. CommScope, Inc.
5. Draka USA.

B. Cable Characteristics: Broadband type, recommended by cable manufacturer specifically for broadband data transmission applications. Coaxial cable and accessories shall have 75-ohm nominal impedance with a return loss of 20 dB maximum from 7 to 806 MHz.

C. RG-6/U: NFPA 70, Type CATV or CM.

1. No. 16 AWG, solid, copper-covered steel conductor; gas-injected, foam-PE insulation.
2. Double shielded with 100 percent aluminum-foil shield and 60 percent aluminum braid.
3. Jacketed with black PVC or PE.
4. Suitable for indoor installations.

2.6 COAXIAL CABLE HARDWARE

A. Manufacturers: Subject to compliance with requirements, acceptable manufacturers offering products that may be incorporated into the Work include, but are not limited to, the following:

1. Aim Electronics; a brand of Emerson Electric Co.
2. Leviton Voice & Data Division.
3. Siemon Co. (The).

B. Coaxial-Cable Connectors: Type F, 75 ohms - compression.

2.7 MULTIMODE OPTICAL FIBER CABLE

- A. Reference special provisions Section 655 (Communications) for requirements of multimode fiber optic cable.
- B. Manufacturers: Subject to compliance with requirements, available manufacturers offering products that may be incorporated into the Work include, but are not limited to, the following:
 - 1. CommScope, Inc.
 - 2. Corning Cable Systems.
 - 3. General Cable Technologies Corporation.
 - 4. Mohawk; a division of Belden CDT.
 - 5. Superior Essex Inc.
- C. Description: OM1 multimode, 62.5/125-micrometer, nonconductive, indoor/outdoor, tight buffer, optical fiber cable. Provide total number of cables as indicated on plans.
 - 1. Comply with ICEA S-83-596 for mechanical properties.
 - 2. Shall have a minimum of 6 strands.
 - 3. Comply with TIA-568-C.3 for performance specifications.
 - 4. Listed and labeled by an NRTL acceptable to authorities having jurisdiction as complying with UL 444, UL 1651, and NFPA 70 for the following types:
 - a. Plenum Rated, Nonconductive: Type OFNP, dry water blocking, complying with NFPA 262.
 - 5. Maximum Attenuation: 3 dB/km at 850 nm and 1dB/km at 1300 nm.
- D. Jacket:
 - 1. Jacket Color: Orange.
 - 2. Cable cordage jacket, fiber, unit, and group color shall be according to TIA-598-B.
 - 3. Imprinted with fiber count, fiber type, and aggregate length at regular intervals not to exceed 40 inches.

2.8 OPTICAL FIBER CABLE HARDWARE

- A. Manufacturers: Subject to compliance with requirements, available manufacturers offering products that may be incorporated into the Work include, but are not limited to, the following:
 - 1. Corning Cable Systems.
 - 2. Hubbell Premise Wiring.
 - 3. Molex Premise Networks; a division of Molex, Inc.
 - 4. Ortronics/Legrand
 - 5. Panduit.
- B. Cross-Connects and Patch Panels: Rack mounted modular panels housing multiple-numbered, duplex ST cable connectors. Bi-directions sliding draws for both front and rear access to fibers and fiber optic splice trays.

1. Number of Connectors per Field: One for each fiber of cable or cables assigned to field, plus 25 percent spare and blank positions.
- C. Patch Cords: Factory-made, OM1 multimode single fiber patch cables, with ST connectors at patch panel and LC connectors as required for connection to SFPs, in the following quantities and lengths:
 1. Twenty-five (25) – 3-meter lengths - Orange.
- D. Pigtails: Factory-made, OM1 multimode single fiber 900micron pigtails.
 1. Factory-made.
 2. Furnish, and fusion splice, one for each strand of each multimode fiber optic cable for termination onto fiber patch panels.
 3. Comply with TIA-568-C.3 performance requirements.
 4. ST to pigtail.
 5. ST connector housing and boot colors follow TIA-568-C.3 suggested color identification scheme.
 6. Insertion loss per connection: 0.1dB typical, 0.25dB maximum.
- E. Cable Connecting Hardware:
 1. Comply with Optical Fiber Connector Intermateability Standards (FOCIS) specifications of TIA-604-2, TIA-604-3-A, and TIA-604-12. Comply with TIA-568-C.3.
 2. Quick-connect, simplex and duplex, Type LC connectors. Insertion loss not more than 0.75 dB.

2.9 TELECOMMUNICATIONS OUTLET/CONNECTORS

- A. Jacks: 100-ohm, balanced, twisted-pair connector; four-pair, eight-position modular. Comply with TIA-568-C.1 Category 6A.
 1. Jacks shall be colored to match connecting CAT6A cable
- B. Workstation Outlets: two-port connector assemblies mounted in single faceplate or as shown on drawings.
 1. Plastic Faceplate: High-impact plastic.
 2. Stainless Steel recessed wall plate with mounting studs.

2.10 GROUNDING

- A. Comply with requirements in "Grounding and Bonding for Electrical Systems" for grounding conductors and connectors.
- B. Comply with J-STD-607-A.

2.11 IDENTIFICATION PRODUCTS

- A. Comply with TIA-606-A and UL 969 for labeling materials, including label stocks, laminating adhesives, and inks used by label printers.
- B. Label all new cables with identification on both cable ends including: "Cable type", "Cable to", and "Cable from". Comply with labeling standard recommendations of TIA-606-A.

PART 3 - EXECUTION

3.1 PREPARATION

- A. Perform testing as specified in Part 3 "Field Quality Control" Article.

3.2 WIRING METHODS

- A. Install cables in pathways.
- B. Wiring within Enclosures:
 - 1. Bundle, lace, and train conductors to terminal points with excess and without exceeding manufacturer's limitations on bending radii.
 - a. Provide a minimum of twenty (20) feet of excess for all fiber optic cabling and spool in patch panels and/or handholes.
 - 2. Install lacing bars and distribution spools.
 - 3. Install conductors parallel with or at right angles to sides and back of enclosure.

3.3 INSTALLATION OF CABLES

- A. Comply with NECA 1.
- B. General Requirements for Cabling:
 - 1. Comply with TIA-568-C.1.
 - 2. Comply with BICSI ITSIM, Ch. 6, "Cable Termination Practices."
 - 3. Install 110-style IDC termination Category 6A hardware unless otherwise indicated.
 - 4. Terminate conductors; no cable shall contain unterminated elements. Make terminations only at indicated outlets, terminals, cross-connects, and patch panels.
 - 5. Cables may not be spliced. Secure and support cables at intervals not exceeding 30 inches (760 mm) and not more than 6 inches (150 mm) from cabinets, boxes, fittings, outlets, racks, frames, and terminals.
 - 6. Install lacing bars to restrain cables, to prevent straining connections, and to prevent bending cables to smaller radii than minimums recommended by manufacturer.

7. Bundle, lace, and train conductors to terminal points without exceeding manufacturer's limitations on bending radii, but not less than radii specified in BICSI ITSIM, "Cabling Termination Practices". Install lacing bars and distribution spools.
8. Do not install bruised, kinked, scored, deformed, or abraded cable. Do not splice cable between termination, tap, or junction points. Remove and discard cable if damaged during installation and replace it with new cable.
9. Pulling Cable: Comply with BICSI ITSIM, Chapter 4, "Pulling Cable." Monitor cable pull tensions.

C. UTP Cable Installation:

1. Comply with TIA-568-C.2.
2. Do not untwist UTP cables more than 1/2 inch (12 mm) from the point of termination to maintain cable geometry.

D. Optical Fiber Cable Installation:

1. Comply with TIA-568-C.3.
2. Cable shall only be terminated on connecting hardware that is rack or cabinet mounted.

E. Group connecting hardware for cables into separate logical fields.

F. Separation from EMI Sources:

1. Comply with BICSI TDMM and TIA-569-B for separating unshielded copper voice and data communication cable from potential EMI sources, including electrical power lines and equipment.
2. Separation between open communications cables or cables in nonmetallic raceways and unshielded power conductors and electrical equipment shall be as follows:
 - a. Electrical Equipment Rating Less Than 2 kVA: A minimum of 5 inches (127 mm).
 - b. Electrical Equipment Rating between 2 and 5 kVA: A minimum of 12 inches (300 mm).
 - c. Electrical Equipment Rating More Than 5 kVA: A minimum of 24 inches (610 mm).
3. Separation between communications cables in grounded metallic raceways and unshielded power lines or electrical equipment shall be as follows:
 - a. Electrical Equipment Rating Less Than 2 kVA: A minimum of 2-1/2 inches (64 mm).
 - b. Electrical Equipment Rating between 2 and 5 kVA: A minimum of 6 inches (150 mm).
 - c. Electrical Equipment Rating More Than 5 kVA: A minimum of 12 inches (300 mm).

4. Separation between communications cables in grounded metallic raceways and power lines and electrical equipment located in grounded metallic conduits or enclosures shall be as follows:
 - a. Electrical Equipment Rating Less Than 2 kVA: No requirement.
 - b. Electrical Equipment Rating between 2 and 5 kVA: A minimum of 3 inches (76 mm).
 - c. Electrical Equipment Rating More Than 5 kVA: A minimum of 6 inches (150 mm).
5. Separation between Communications Cables and Electrical Motors and Transformers, 5 kVA or HP and Larger: A minimum of 48 inches (1200 mm).
6. Separation between Communications Cables and Fluorescent Fixtures: A minimum of 5 inches (127 mm).

3.4 FIRESTOPPING

- A. Comply with TIA-569-B, Annex A, "Firestopping."
- B. Comply with BICSI TDMM, "Firestopping Systems" Article.

3.5 GROUNDING

- A. Install grounding according to BICSI TDMM, "Grounding, Bonding, and Electrical Protection" Chapter.
- B. Comply with J-STD-607-A.

3.6 IDENTIFICATION

- A. Identify system components, wiring, and cabling complying with TIA-606-A.
 1. Color-code cross-connect fields. Apply colors to voice and data service backboards, connections, covers, and labels.
- B. Cable Schedule: Post in prominent location in each equipment room and wiring closet. List incoming and outgoing cables and their designations, origins, and destinations. Protect with rigid frame and clear plastic cover. Furnish an electronic copy of final comprehensive schedules for Project.
- C. Cabling Administration Drawings: Show building floor plans with cabling administration-point labeling. Identify labeling convention and show labels for telecommunications closets, backbone pathways and cables, entrance pathways and cables, terminal hardware and positions, horizontal cables, work areas and workstation terminal positions, grounding buses and pathways, and equipment grounding conductors. Follow convention of TIA-606-A. Furnish electronic record of all drawings, in software and format approved by the MTA.

D. Cable and Wire Identification:

1. Label each cable within 4 inches (100 mm) of each termination and tap, where it is accessible in a cabinet or junction or outlet box, and elsewhere as indicated.
2. Exposed Cables and Cables in Cable Trays and Wire Troughs: Label each cable at intervals not exceeding 15 feet (4.5 m).
3. Label each terminal strip and screw terminal in each cabinet, rack, or panel.
 - a. Individually number wiring conductors connected to terminal strips, and identify each cable or wiring group being extended from a panel or cabinet to a building-mounted device shall be identified with name and number of particular device as shown.
 - b. Label each unit and field within distribution racks and frames.
4. Identification within Connector Fields in Equipment Rooms and Wiring Closets: Label each connector and each discrete unit of cable-terminating and connecting hardware.

E. Labels shall be preprinted or computer-printed type with printing area and font color that contrasts with cable jacket color but still complies with requirements in TIA-606-A.

1. Cables use flexible vinyl or polyester that flex as cables are bent.

3.7 FIELD QUALITY CONTROL

A. Perform the following tests and inspections:

1. Visually inspect all cable jacket materials for NRTL certification markings. Inspect cabling terminations in communications equipment rooms for compliance with color-coding for pin assignments, and inspect cabling connections for compliance with TIA-568-C.1.
2. Visually confirm Category 6A, marking of outlets, cover plates, outlet/connectors, and patch panels.
3. Visually inspect cable placement, cable termination, grounding and bonding, equipment and patch cords, and labeling of all components.
4. Test UTP copper cabling for DC loop resistance, shorts, opens, intermittent faults, and polarity between conductors. Test operation of shorting bars in connection blocks. Test cables after termination but not cross-connection.
 - a. Test instruments shall meet or exceed applicable requirements in TIA-568-C.2. Perform tests with a tester that complies with performance requirements in "Test Instruments (Normative)" Annex, complying with measurement accuracy specified in "Measurement Accuracy (Informative)" Annex. Use only test cords and adapters that are qualified by test equipment manufacturer for channel or link test configuration.
5. UTP Performance Tests:
 - a. Test for each outlet. Perform the following tests according to TIA-568-C.1 and TIA-568-C.2:

- 1) Wire map.
 - 2) Length (physical vs. electrical, and length requirements).
 - 3) Insertion loss.
 - 4) Near-end crosstalk (NEXT) loss.
 - 5) Power sum near-end crosstalk (PSNEXT) loss.
 - 6) Equal-level far-end crosstalk (ELFEXT).
 - 7) Power sum equal-level far-end crosstalk (PSELFEXT).
 - 8) Return loss.
 - 9) Propagation delay.
 - 10) Delay skew.
6. Final Verification Tests: Perform verification tests for UTP systems after the complete communications cabling and workstation outlet/connectors are installed.
7. Optical Fiber Cable Tests:
- a. All fiber terminations and testing shall be completed by a technician certified to perform this work. Resumes or personnel will be required for approval.
 - b. Test instruments shall meet or exceed applicable requirements in TIA-568-C.1. Use only test cords and adapters that are qualified by test equipment manufacturer for channel or link test configuration.
 - c. Link End-to-End Attenuation Tests:
 - 1) Multimode measurements: Test at 850nm and 1300nm in both directions (bidirectionally) according to TIA-526-14-A, Method B, One Reference Jumper.
 - 2) Attenuation test results for optical links shall be less than 2.0 dB. Attenuation test results shall be less than that calculated according to equation in TIA-568-C.1.
 - 3) Shall be conducted with an approved OTDR and Power Meter (OLTS).
 - 4) All shall be conducted and analyzed bidirectionally.
- B. Data for each measurement shall be documented. Data for submittals shall be printed in a summary report that is formatted similar to Table 10.1 in BICSI TDMM, or transferred from the instrument to the computer, saved as text files, and printed and submitted.
- C. End-to-end cabling will be considered defective if it does not pass tests and inspections.
- D. Prepare and submit test and inspection reports for MTA acceptance.

END OF SECTION

SECTION 16825

TELECOMMUNICATIONS EQUIPMENT

PART 1 - GENERAL

1.1 SUMMARY

A. Section Includes:

1. Equipment Frames.
2. Ethernet Switches.
3. Uninterruptable Power Supplies (UPS).
4. LED Video Display.
5. Small Form Factor (SFF) Computer.
6. Grounding
7. Identification Products
8. ITS CCTV Pole
9. ITS Equipment cabinet
10. ITS CCTV Camera

B. Related Requirements:

1. Section 16800 "Telecommunications Cabling"

1.2 SUBMITTALS

- A. As-Built Drawings. Submit prior to final acceptance of the work, drawings showing complete layout of equipment installed.
- B. Field Quality Control Test Report. Submit reports complying with requirements of Part 3 "Field Quality Control" Article.

1.3 DEFINITIONS

- A. BICSI: Building Industry Consulting Service International.
- B. Cross-Connect: A facility enabling the termination of cable elements and their interconnection or cross-connection.
- C. EMI: Electromagnetic interference.
- D. IDC: Insulation displacement connector.
- E. LAN: Local Area Network.
- F. Outlet/Connectors: A connecting device in the work area on which horizontal cable or outlet cable terminates.

- G. RCDD: Registered Communications Distribution Designer.
- H. UTP: Unshielded twisted pair.

PART 2 - PRODUCTS

2.1 UNINTERRUPTABLE POWER SUPPLY (UPS)

- A. UPS will be supplied by the Authority and installed by the Contractor for the MTA Communications Room equipment.

2.2 ETHERNET SWITCHES

A. Administrative Ethernet Switch

1. Administrative Ethernet switch shall be a commercial-grade, forty-eight (48) port, 10/100/1000 compliant Ethernet switch with at least four (4) SPF slots supporting industry standard mini-GBIC optical or copper transceivers.
2. Administrative Ethernet switch shall be compatible with EIA 310-D standard, 19-inch (480-mm) panel mounting and be mounted in the Floor-Mounted Equipment Rack in the MTA Communications Room (Room 001A) as indicated on plans.

B. Security Ethernet Switch

1. Security Ethernet switch shall be a commercial-grade, twenty-four (24) port, 10/100/1000 compliant Ethernet switch with at least two (2) SPF slots supporting industry standard mini-GBIC optical or copper transceivers.
2. Security Ethernet switch shall support the 802.3af power over Ethernet (POE) standard.
3. Security Ethernet switch shall be compatible with EIA 310-D standard, 19-inch (480-mm) panel mounting and be mounted in the Floor-Mounted Equipment Rack in the MTA Communications Room (Room 001A) as indicated on plans.

2.3 LED VIDEO DISPLAY

- A. Provide one (1) Professional, commercial-grade LED Flat Panel Video Display and ceiling-mount for installation in the Supervisor Room (Room 102). LED Flat Panel shall have the following minimum specifications.

1. 50" Diagonal viewing area.
2. Professional/commercial-grade designed for 24/7 operation.
3. Full HD 1080p resolution (1920 x 1080).
4. Dynamic Contrast Ratio: 80,000:1.
5. Mounting Size: VESA 400 x 400 (mm).
6. Thin bezel, black color exterior case.
7. Exceeds ENERGY STAR standards.
8. HDMI and PC inputs.

2.4 SMALL FORM FACTOR (SFF) COMPUTER

A. Product Description

1. The SFF computer shall receive streaming video content from the Network ITS cameras for display on the LED Flat Panel Video Display. The SFF computer shall work independently and without attendance of any personnel. The functions available on the SFF computer shall be accessible by authorized users.
2. The SFF computer shall be of an ultra-compact format and mounted behind the LED Flat Panel Video Display.
3. Include one (1) HDMI cable, 3ft., to connect to the LED Flat Panel Video Display.

B. SFF minimum Computer Requirements

1. The SFF computer shall conform to the following minimum specifications:
 - a. CPU: Intel® Core™ i7-6700T (2.8 GHz, up to 3.6 GHz w/Turbo Boost, 8 MB cache, 4 cores).
 - b. RAM: 16GB DDR4.
 - c. Network: Wired Ethernet 10/100/1000 Mbps, auto.
 - d. Graphics Adapter: Intel® HD Graphics 530 with HDMI.
 - e. Hard Disk Type: 128 GB SATA, 2.5" SSD.
 - f. Input Device: Wireless Keyboard and Mouse.
 - g. Operating System: Windows 10 Pro 64bit.

2.5 GROUNDING

- A. Comply with requirements in "Grounding and Bonding for Electrical Systems" for grounding conductors and connectors.
- B. Comply with J-STD-607-A.

2.6 IDENTIFICATION PRODUCTS

- A. Comply with TIA-606-A and UL 969 for labeling materials, including label stocks, laminating adhesives, and inks used by label printers.
- B. Label all new cables with identification on both cable ends including: "Cable type", "Cable to", and "Cable from"

2.7 ITS CCTV POLE

- A. The Contractor shall furnish and install a ITS CCTV camera poles with anchor bolts and foundation; mounting brackets for CCTV; weatherheads for future ITS equipment; testing; all cable and wiring; ground rods, equipment grounding and bonding; and all other equipment, materials and incidental items necessary to provide a complete, fully operational camera pole.
- B. Camera Poles shall be a galvanized steel pole.and include mounting hardware for camera/dome assembly.
- C. Two 2” Weatherheads – weatherheads shall be factory installed at approximately 20 feet from the base and 5 feet from the top of the pole and reinforced. Field drilling will not be allowed.
- D. 3” Condulet for wire access between the pole and cabinet.
- E. The contractor shall supply and install a lightning dissipater mounted to the camera pole, approximately 72” in length, be candelabra type and shall provide a minimum of three spot dissipaters, and shall use all Stainless steel hardware.
- F. The height of the pole shall be as specified in the contract documents.
- G. The pole shall be able to sustain 110 MPH winds. The maximum horizontal deflection at the top of the pole completely assembled with a camera and other fixtures shall not exceed 1.25” in any direction under a steady, non-gust wind of 50 MPH.
- H. The pole shall be constructed of galvanized steel and high strength low-alloy steel conforming to A595, Grade A, unless otherwise noted.
- I. All weatherheads, hand holes, conduit access points shall be factory installed and no field drilling shall be allowed. The dome shall be mounted on the side closest to the road to provide a maximum unobstructed view of the mainline and/or toll zone.

2.8 ITS EQUIPMENT CABINET

- A. The Contractor shall furnish and install a Pole Mounted ITS Equipment Cabinet, at each CCTV Pole as indicated on the contract Documents.
- B. The ITS field cabinet shall meet NEMA 3R requirements.
- C. The cabinet shall be equipped with standard 19” EIA rack rails with both upper and lower mounting straps and shall be UL listed. 19” Rack mounted shelves and/or DIN rails shall be provided for equipment that cannot be rack mounted.
- D. The minimum cabinet dimensions shall be 24”W x 46”H x 20”D and shall be sized to house the proposed equipment with an additional 50% spare rack space for future expansion.
- E. The cabinet for the CCTV shall be pole mounted.

- F. The cabinet shall have two full size locking doors located on opposite sides of the cabinet, hinged on the right or left depending on field conditions.
- G. A 3'0" x 2'6" x 4" cement concrete work pad shall be installed in front of each cabinet door. The pad shall be placed on a minimum of 4-inches of compacted granular material. The pad shall be set with at least 1 percent grade such that any water on the pad shall flow away from the cabinet.
- H. The doorframe openings shall be flanged in all four sides. These flanges should increase the strength and prevent dust and liquids from entering the enclosure when the doors are opened. The door seals shall have a rubber gasket to provide a weather tight seal.
- I. The cabinet shall have a sunshield that covers the top.
- J. The doors shall be equipped with three-point latching mechanisms with nylon rollers at the top and bottom.
- K. The cabinet enclosure shall be 0.125" thick and made of aluminum alloy Type 5052.
- L. The door handles shall be 0.75" stainless steel round bars and have provision for a padlock.
- M. All exterior seams shall be sealed tight with a silicone sealant.
- N. The cabinet shall be supplied with captive door restraint bars.
- O. The bars shall allow the doors to be kept open at a minimum of two different angles one at 90 degrees and the other in a fully open position).
- P. Ventilation in the cabinet shall consist of a thermostatically controlled 100 CFM fan with louvered air intake in the doors, with pleated filters.
- Q. The cabinet shall be mounted to the pole at a height that allows the technician access while standing on the foundation (ground level) or maintenance pad. The bottom of the cabinet shall be at least 2 feet above the foundation, and the top shall be no more than 7 feet above the foundation.

2.9 ITS CCTV CAMERA

- A. The zoom ratio shall be 35x Optical, 12x Digital, minimum.
- B. The camera shall be an IP type CCTV camera.
- C. The camera shall have an auto focus with manual override capability.
- D. The camera shall have lens aperture ratio of: f/1.4 to f/3.7 (wide to telephoto).
- E. The camera shall support variable zoom lens speeds.
- F. The CCTV camera shall display on-screen azimuth and elevation position indications in degrees and optical and digital zoom levels.

- G. The DB Entity shall program the CCTV camera with up to four zones, including at a minimum: North, South, East, and West directional zones.
- H. The CCTV camera shall be programmable to blank out up to eight (8), four-sided areas to electronically block portions of the camera's field of view from being displayed. These privacy zones shall move and adjust sizing synchronously with camera movements and degree of lens zooming.
- I. The CCTV camera shall display a minimum of 20 programmable characters for on-screen camera ID, preset position, sector, and alarm titles.
- J. The position of the on-screen text shall be adjustable to appear at selectable positions on the CCTV camera screen image.
- K. The camera shall provide a variable speed tilt speed range of up to 180° per second.
- L. The camera shall provide a variable speed pan speed range of up to 180° per second.
- M. The camera Pan/Tilt mechanism shall provide a proportional speed Pan and Tilt ability, where the speed decreases automatically as the zoom level increases.
- N. The camera shall provide a 360° continuous pan rotation without mechanical interference.
- O. The camera shall provide a 180° tilt range.
- P. The CCTV camera assembly shall include an auto-flip function to automatically reposition the camera 180-degrees for uninterrupted viewing, in the correct orientation, as the camera moves to view objects beneath the dome.
- Q. The camera shall include a minimum of 80 presets. The movement to the preset shall occur within one second (maximum) and with a 0.1 degree of positioning accuracy.
- R. The CCTV camera shall include titles for each preset with a minimum of 20 characters per preset title.
- S. The camera shall provide a minimum of 704H x 576V effective pixels.
- T. The camera shall include an image sensor of 1/3 or 1/4 inch, nominal.
- U. The camera shall include a zoom lens of 3.4 mm to 119 mm, minimum focal length.
- V. The camera shall have Color and Black & White video image display modes incorporating both automatic and manual override image mode selection. The camera shall transition automatically to a Black & White mode (when in automatic mode) when the luminance level reaches a user predefined threshold. At all times the camera shall provide a full motion video output at 30 frames per second.
- W. The CCTV camera shall incorporate electronic image stabilization to reduce the effects of vibration and wind gusts on the displayed video image.

- X. The camera shall include both automatic iris control and an override for manual iris adjustments.
- Y. The CCTV camera's wide dynamic range shall be $\geq 128X$.
- Z. The camera's sensitivity shall be sufficient to provide a clear, usable color video image display with a scene illumination of ≤ 0.7 lux at an aperture of F1.6, nominal.
- AA. The camera dome housing shall be provided by the camera manufacturer as an integrated product. See Dome Requirements, below.
- BB. The power input requirements for the CCTV camera and dome shall be 24 VAC, or PoE+; selectable.
- CC. No alarm contacts shall be wired.
- DD. Unless otherwise specified, the equipment inside the CCTV camera shall remain functional with outside temperatures ranging from -40°C to 50°C (-40°F to 122°F).
- EE. The camera and dome assembly shall sustain normal operations when subject to transient voltages, power surges, and sags.
- FF. The camera manufacturer shall have a minimum of 12 installed units of dome type CCTV cameras at outdoor installations for ITS applications, operational for at least six (6) months.
- GG. The DB Entity shall have a named Systems Integrator with CCTV and IP networking experience (including experience with CCTV hardware, systems interconnection and IP network configuration). The DB Entity and/or systems integrator shall have installed at least two (2) similar CCTV systems with 12 or more cameras, operational for at least six (6) months.
- HH. The dome shall be a maximum of 12" diameter. Unless otherwise specified, the equipment inside the dome shall remain functional with outside temperatures ranging -40°C to 50°C (-40°F to 122°F). Unless otherwise specified, the equipment inside the dome shall remain functional with an outside relative humidity from 10-100%. The dome enclosure shall include a heater, as required to maintain the specified operational temperature range. The camera and dome shall withstand 90 MPH winds. The maximum total weight for the combined CCTV camera and dome assembly shall be 15 lbs or less. The dome assembly shall be sealed and shall be rated IP66, or better, for ingress protection against air contaminants and water.
- II. The CCTV assembly shall be suitable for the environment within which it is to be installed.
- JJ. The lower dome cover shall be distortion free, optically corrected, acrylic plastic with no fastening holes or other visual impairments.
- KK. The camera and dome assembly shall include a single composite cable containing a CAT 6 network cable for connection to the IP CCTV Camera, 22 AWG stranded and shielded conductors for data communication spares, 16 AWG stranded conductors for

camera power, heater power and ground. This cable shall be integral to the camera lowering system specified elsewhere in these Special Provisions. Cabling shall terminate into a single MS-style connector that plugs into the top of the dome. The only cable permitted to move within the pole or lowering device during lowering or rising shall be the stainless steel lowering cable. All other cables must remain stable and secure during lowering and raising operations.

- LL. The dome shall accommodate mounting on a steel pole that includes a camera lowering system. The camera and dome mounting shall allow the entire assembly to be lowered for maintenance or repair. No maintenance shall be required in the raised position. The mounting shall permit the camera to view 2° above horizontal. The mounting shall also support a pole-to-camera rotating tenon that allows the camera to be horizontally rotated as desired. The DB Entity shall seal the top of the camera dome to assure weather tightness.
- MM. The pendent mount connector type shall be a 1.5” NTP male thread.
- NN. There shall be surge protection within the dome enclosure for the signal and power. This surge protection is in addition to the surge protection specified for use in the CCTV Equipment Cabinet.
- OO. Power Input to the IP CCTV Camera shall be Power over Ethernet (PoE) or 24 VAC nominal; and shall include powering the camera heater.
- PP. The dome manufacturer shall have a minimum of 12 installed units of dome type CCTV cameras at outdoor locations used for ITS applications and operational for at least six (6) months.
- QQ. The camera and dome assembly manufacturer shall provide a twelve month minimum warranty, from the date of installation.

PART 3 - EXECUTION

3.1 INSTALLATION

- A. Comply with NECA 1.
- B. Comply with BICSI TDMM for layout and installation of communications equipment rooms.
- C. Bundle, lace, and train conductors and cables to terminal points without exceeding manufacturer's limitations on bending radii. Install lacing bars and distribution spools.
- D. Coordinate layout and installation of communications equipment with Owner's telecommunications and LAN equipment and service suppliers. Coordinate service entrance arrangement with local exchange carrier.

1. Meet jointly with Owner's Security and Information Technology Department representatives, and Owner to exchange information and agree on details of equipment arrangements and installation interfaces.
 2. Record agreements reached in meetings and distribute them to other participants.
 3. Adjust arrangements and locations of distribution frames, cross-connects, and patch panels in equipment rooms to accommodate and optimize arrangement and space requirements as shown on plans.
 4. Adjust arrangements and locations of equipment with distribution frames, cross-connects, and patch panels of cabling systems of other communications, electronic safety and security, and related systems that share space in the MTA Communications Room (Room 001A).
- E. Coordinate location of power raceways and receptacles with locations of communications equipment requiring electrical power to operate.
- F. Install Telecommunications Equipment Infrastructure according to manufacturer's specifications and guidelines. Coordinate with other trades for complete installation, fittings and additional accoutrements.
- 3.2 SLEEVE AND SLEEVE SEAL INSTALLATION FOR ELECTRICAL PENETRATIONS
- A. Install sleeves and sleeve seals at penetrations of exterior floor and wall assemblies. Comply with all State, Federal and AHJ requirements.
- 3.3 FIRESTOPPING
- A. Comply with all State, Federal and AHJ requirements.
- B. Comply with TIA-569-B, Annex A, "Firestopping."
- C. Comply with BICSI TDMM, "Firestopping Systems" Article.
- 3.4 GROUNDING
- A. Install grounding according to BICSI TDMM, "Grounding, Bonding, and Electrical Protection" Chapter.
- B. Comply with J-STD-607-A.
- C. Connect grounding with a minimum No. 6 AWG grounding electrode conductor to suitable electrical building ground.
- D. Bond metallic equipment to ground, using not smaller than No. 6 AWG equipment grounding conductor.

3.5 IDENTIFICATION

- A. Identify system components, wiring, and cabling complying with TIA-606-A.
- B. Labels shall be preprinted or computer-printed type.
- C. Label all Equipment Racks by number with phenolic engraved plates – yellow background with black text.

END OF SECTION

MAINE TURNPIKE AUTHORITY

MAINE TURNPIKE

PART IV – APPENDICES

(This page left intentionally blank)

APPENDIX A

SUBSURFACE WASTEWATER

DISPOSAL SYSTEM APPLICATION

(This page left intentionally blank)

SUBSURFACE WASTEWATER DISPOSAL SYSTEM APPLICATION

Maine Dept. of Health & Human Services
 Division of Environmental Health, 11 SHS
 (207) 287-5672 Fax: (207) 287-4172

PROPERTY LOCATION		>> CAUTION: LPI APPROVAL REQUIRED <<	
City, Town, or Plantation	York	Town/City _____	Permit # _____
Street or Road	Chases Pond Road	Date Permit Issued ___/___/___	Fee: \$ _____ Double Fee Charged []
Subdivision, Lot #		Local Plumbing Inspector Signature _____ L.P.I. # _____	

OWNER/APPLICANT INFORMATION		The Subsurface Wastewater Disposal System shall not be installed until a Permit is issued by the Local Plumbing Inspector. The Permit shall authorize the owner or installer to install the disposal system in accordance with this application and the Maine Subsurface Wastewater Disposal Rules.
Name (last, first, MI)	<input checked="" type="checkbox"/> Owner Maine Turnpike Authority <input type="checkbox"/> Applicant	
Mailing Address of Owner/Applicant	2360 Congress Street Portland, ME 04102	
Daytime Tel. #	(207) 871-1771	
		Municipal Tax Map # _____ Lot # _____

OWNER OR APPLICANT STATEMENT	CAUTION: INSPECTION REQUIRED
I state and acknowledge that the information submitted is correct to the best of my knowledge and understand that any falsification is reason for the Department and/or Local Plumbing Inspector to deny a Permit.	I have inspected the installation authorized above and found it to be in compliance with the Subsurface Wastewater Disposal Rules Application.
_____ Signature of Owner or Applicant Date	_____ Local Plumbing Inspector Signature (2nd) date approved

PERMIT INFORMATION		
TYPE OF APPLICATION <input checked="" type="checkbox"/> 1. First Time System <input type="checkbox"/> 2. Replacement System Type replaced: _____ Year installed: _____ <input type="checkbox"/> 3. Expanded System <input type="checkbox"/> a. <25% Expansion <input type="checkbox"/> b. >25% Expansion <input type="checkbox"/> 4. Experimental System <input type="checkbox"/> 5. Seasonal Conversion	THIS APPLICATION REQUIRES <input checked="" type="checkbox"/> 1. No Rule Variance <input type="checkbox"/> 2. First Time System Variance <input type="checkbox"/> a. Local Plumbing Inspector Approval <input type="checkbox"/> b. State & Local Plumbing Inspector Approval <input type="checkbox"/> 3. Replacement System Variance <input type="checkbox"/> a. Local Plumbing Inspector Approval <input type="checkbox"/> b. State & Local Plumbing Inspector Approval <input type="checkbox"/> 4. Minimum Lot Size Variance <input type="checkbox"/> 5. Seasonal Conversion Permit	DISPOSAL SYSTEM COMPONENTS <input checked="" type="checkbox"/> 1. Complete Non-engineered System <input type="checkbox"/> 2. Primitive System (graywater & alt. toilet) <input type="checkbox"/> 3. Alternative Toilet, specify: _____ <input type="checkbox"/> 4. Non-engineered Treatment Tank (only) <input type="checkbox"/> 5. Holding Tank, _____ gallons <input type="checkbox"/> 6. Non-engineered Disposal Field (only) <input type="checkbox"/> 7. Separated Laundry System <input type="checkbox"/> 8. Complete Engineered System (2000 gpd or more) <input type="checkbox"/> 9. Engineered Treatment Tank (only) <input type="checkbox"/> 10. Engineered Disposal Field (only) <input type="checkbox"/> 11. Pre-treatment, specify: _____ <input type="checkbox"/> 12. Miscellaneous Components
SIZE OF PROPERTY 33± <input type="checkbox"/> SQ. FT. <input checked="" type="checkbox"/> ACRES	DISPOSAL SYSTEM TO SERVE <input type="checkbox"/> 1. Single Family Dwelling Unit, No. of Bedrooms: _____ <input type="checkbox"/> 2. Multiple Family Dwelling, No. of Units: _____ <input checked="" type="checkbox"/> 3. Other: <u>Administration Building</u> (specify) Current Use <input type="checkbox"/> Seasonal <input type="checkbox"/> Year Round <input checked="" type="checkbox"/> Undeveloped	TYPE OF WATER SUPPLY <input type="checkbox"/> 1. Drilled Well <input type="checkbox"/> 2. Dug Well <input type="checkbox"/> 3. Private <input checked="" type="checkbox"/> 4. Public <input type="checkbox"/> 5. Other

DESIGN DETAILS (SYSTEM LAYOUT SHOWN ON PAGE 3)			
TREATMENT TANK <input checked="" type="checkbox"/> 1. Concrete <input checked="" type="checkbox"/> a. Regular <input type="checkbox"/> b. Low Profile <input type="checkbox"/> 2. Plastic <input type="checkbox"/> 3. Other: _____ CAPACITY: <u>1000</u> GAL.	DISPOSAL FIELD TYPE & SIZE <input type="checkbox"/> 1. Stone Bed <input type="checkbox"/> 2. Stone Trench <input checked="" type="checkbox"/> 3. Proprietary Device <input type="checkbox"/> a. Cluster array <input type="checkbox"/> c. Linear <input type="checkbox"/> b. Regular load <input type="checkbox"/> d. H-20 load <input type="checkbox"/> 4. Other: _____ SIZE: <u>1536</u> sq. ft. <input type="checkbox"/> lin. ft.	GARBAGE DISPOSAL UNIT <input checked="" type="checkbox"/> 1. No <input type="checkbox"/> 2. Yes <input type="checkbox"/> 3. Maybe If Yes or Maybe, specify one below: <input type="checkbox"/> a. multi-compartment tank <input type="checkbox"/> b. ___ tanks in series <input type="checkbox"/> c. increase in tank capacity <input type="checkbox"/> d. Filter on Tank Outlet	DESIGN FLOW <u>408</u> gallons per day BASED ON: <input type="checkbox"/> 1. Table 4A (dwelling unit(s)) <input checked="" type="checkbox"/> 2. Table 4C (other facilities) SHOW CALCULATIONS for other facilities 34 employees @ 12 gpd = 408 gpd
SOIL DATA & DESIGN CLASS PROFILE CONDITION <u>2</u> <u>AIII</u> at Observation Hole # <u>TP-51</u> Depth <u>24</u> " of Most Limiting Soil Factor	DISPOSAL FIELD SIZING <input type="checkbox"/> 1. Medium---2.6 sq. ft. / gpd <input checked="" type="checkbox"/> 2. Medium---Large 3.3 sq. ft. / gpd <input type="checkbox"/> 3. Large---4.1 sq. ft. / gpd <input type="checkbox"/> 4. Extra Large---5.0 sq. ft. / gpd	EFFLUENT/EJECTOR PUMP <input type="checkbox"/> 1. Not Required <input type="checkbox"/> 2. May Be Required <input checked="" type="checkbox"/> 3. Required Specify only for engineered systems: DOSE: _____ gallons	LATITUDE AND LONGITUDE at center of disposal area Lat. <u>43</u> d <u>10</u> m <u>50.0</u> s Lon. <u>-70</u> d <u>38</u> m <u>58.1</u> s

SITE EVALUATOR STATEMENT			
I certify that on <u>2/26/16</u> (date) I completed a site evaluation on this property and state that the data reported are accurate and that the proposed system is in compliance with the State of Maine Subsurface Wastewater Disposal Rules (10-144A CMR 241).			
_____ Site Evaluator Signature	355 SE #	3-15-16 Date	 WWW.SE BAGOTECHNICS.COM
Gary M. Fullerton Site Evaluator Name Printed	(207) 200-2063 Telephone Number	gfullerton@sebagotechnics.com E-mail Address	

Note: Changes to or deviations from the design should be confirmed with the Site Evaluator. Page 1 of 3
HHE-200 Rev. 08/2011

SUBSURFACE WASTEWATER DISPOSAL SYSTEM APPLICATION		Maine Dept. of Health & Human Services Division of Environmental Health, 11 SHS (207) 287-5672 Fax: (207) 287-4172
Town, City, Plantation York	Street, Road, Subdivision Chases Pond Road	Owner or Applicant Name Maine Turnpike Authority

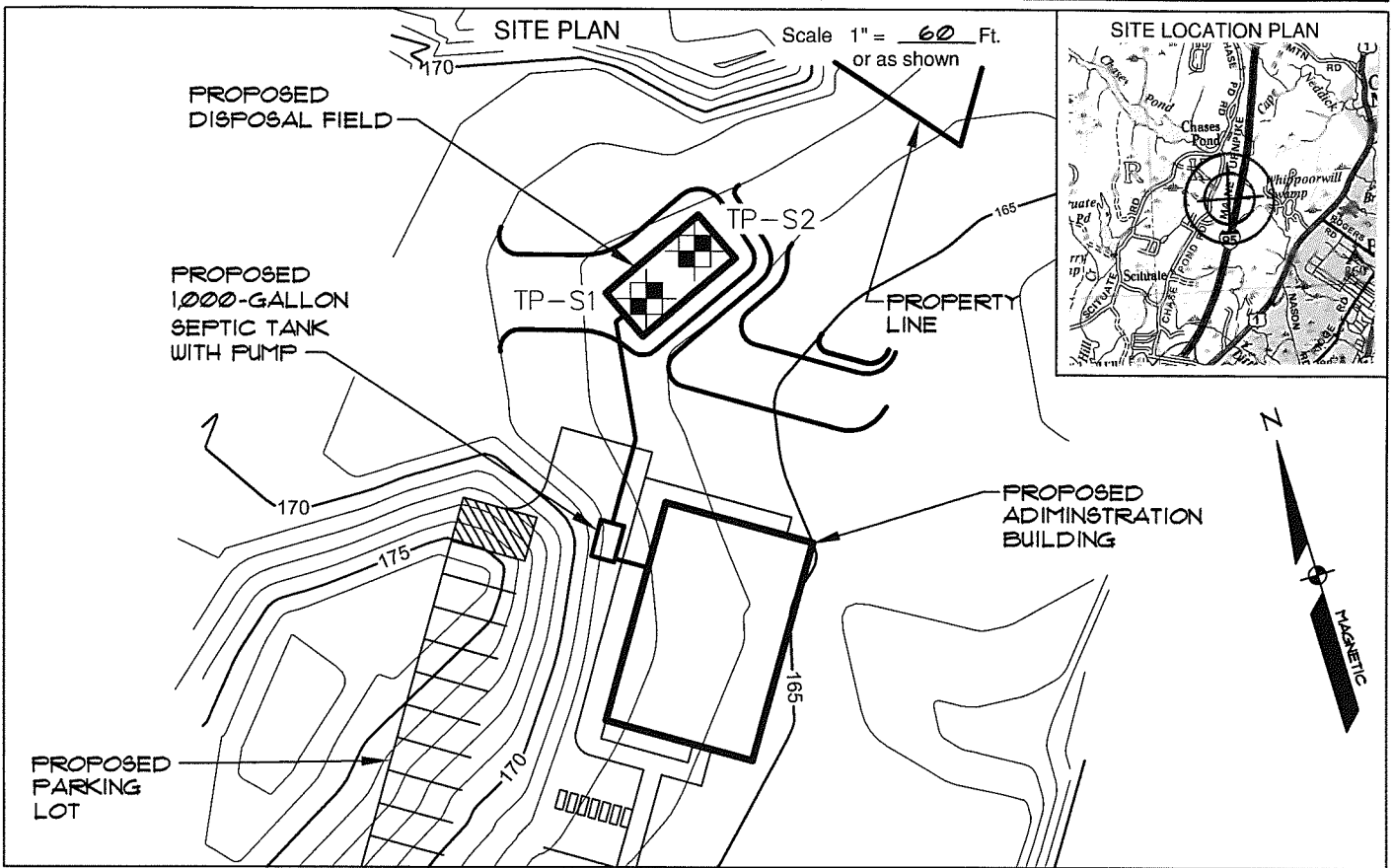

SOIL DESCRIPTION AND CLASSIFICATION (Location of Observation Holes Shown Above)				
Observation Hole <u>TP-S1</u>		<input checked="" type="checkbox"/> Test pit <input type="checkbox"/> Boring 1-2 " Depth of Organic Horizon Above Mineral Soil		
DEPTH BELOW MINERAL SOIL SURFACE (inches)	Texture	Consistency	Color	Mottling
0				
10	FINE SANDY LOAM W/ STONES	FRIABLE	7.5YR 3/4 DARK BROWN	NONE OBSERVED
20				
30	LEDGE/ STONE AT 24"			
40				
50				
Soil Classification <u>2</u> Profile <u>AIII</u> Condition		Slope <u>0-3</u> %	Limiting Factor <u>24</u> "	<input type="checkbox"/> Ground Water Restrictive Layer <input type="checkbox"/> Bedrock <input type="checkbox"/> Pit Depth
Observation Hole <u>TP-S2</u>		<input checked="" type="checkbox"/> Test pit <input type="checkbox"/> Boring 1-2 " Depth of Organic Horizon Above Mineral Soil		
DEPTH BELOW MINERAL SOIL SURFACE (inches)	Texture	Consistency	Color	Mottling
0				
10	FINE SANDY LOAM W/ STONES	FRIABLE	7.5YR 3/4 DARK BROWN	NONE OBSERVED
20				
30	LEDGE/ STONE AT 24"			
40				
50				
Soil Classification <u>2</u> Profile <u>AIII</u> Condition		Slope <u>0-3</u> %	Limiting Factor <u>24</u> "	<input type="checkbox"/> Ground Water Restrictive Layer <input type="checkbox"/> Bedrock <input type="checkbox"/> Pit Depth

[Signature]
355 SE #
3-15-16 Date

Site Evaluator Signature

SUBSURFACE WASTEWATER DISPOSAL SYSTEM APPLICATION

Maine Dept. of Health & Human Services
 Division of Environmental Health, 11 SHS
 (207) 287-5672 Fax: (207) 287-4172

Town, City, Plantation
 York

Street, Road, Subdivision
 Chases Pond Road

Owner or Applicant Name
 Maine Turnpike Authority

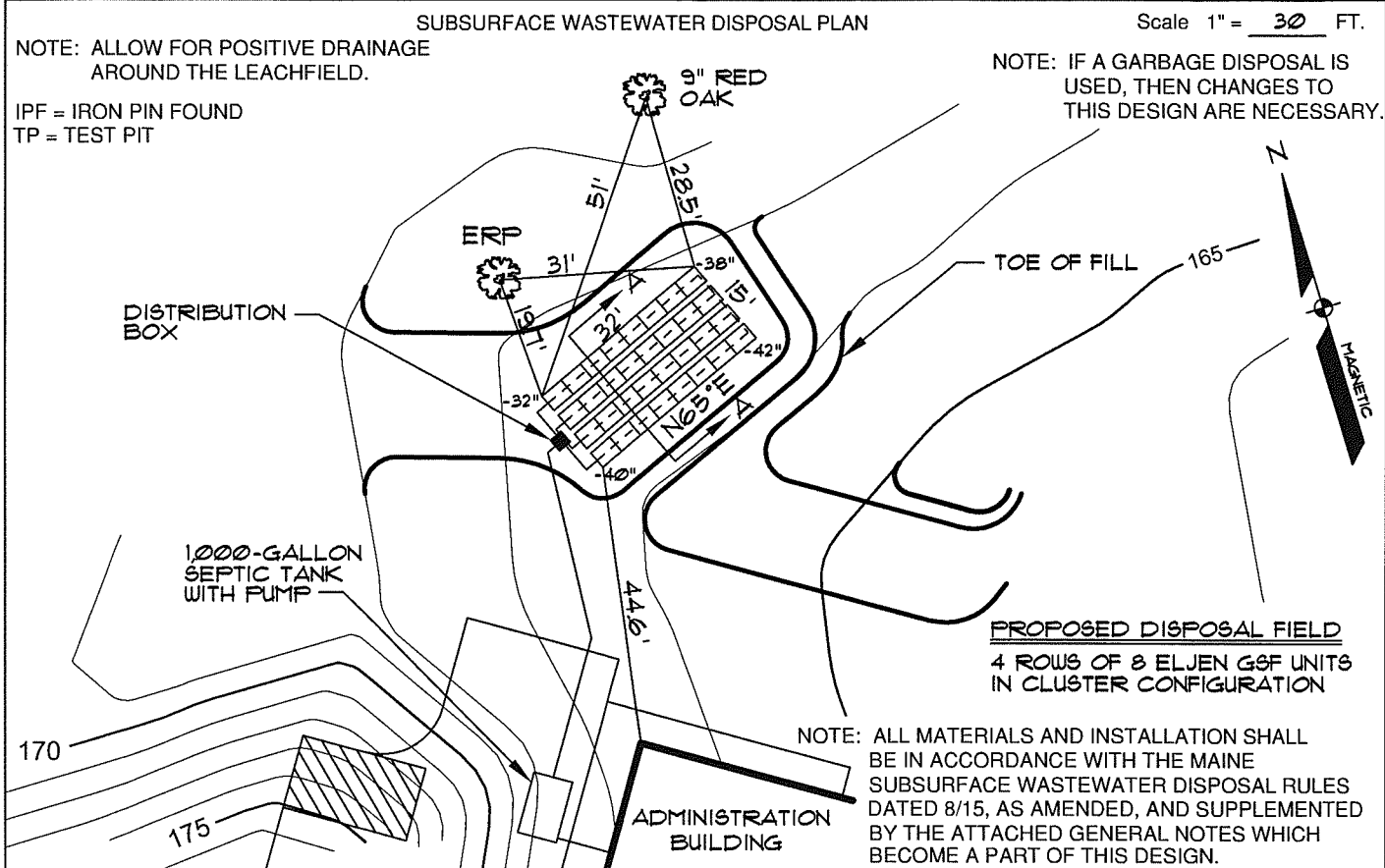

BACKFILL REQUIREMENTS	CONSTRUCTION ELEVATIONS	ELEVATION REFERENCE POINT
Depth of Fill (Upslope) varies (21"-27")	Finished Grade Elevation -11"	Location & Description Nail up 23"
Depth of Fill (Downslope) varies (29"-31")	Top of Distribution Pipe or Proprietary Device -21"	In a 19" diameter White Pine
	Bottom of Disposal Area (Bottom of Eljen) -32"	Reference Elevation 0"

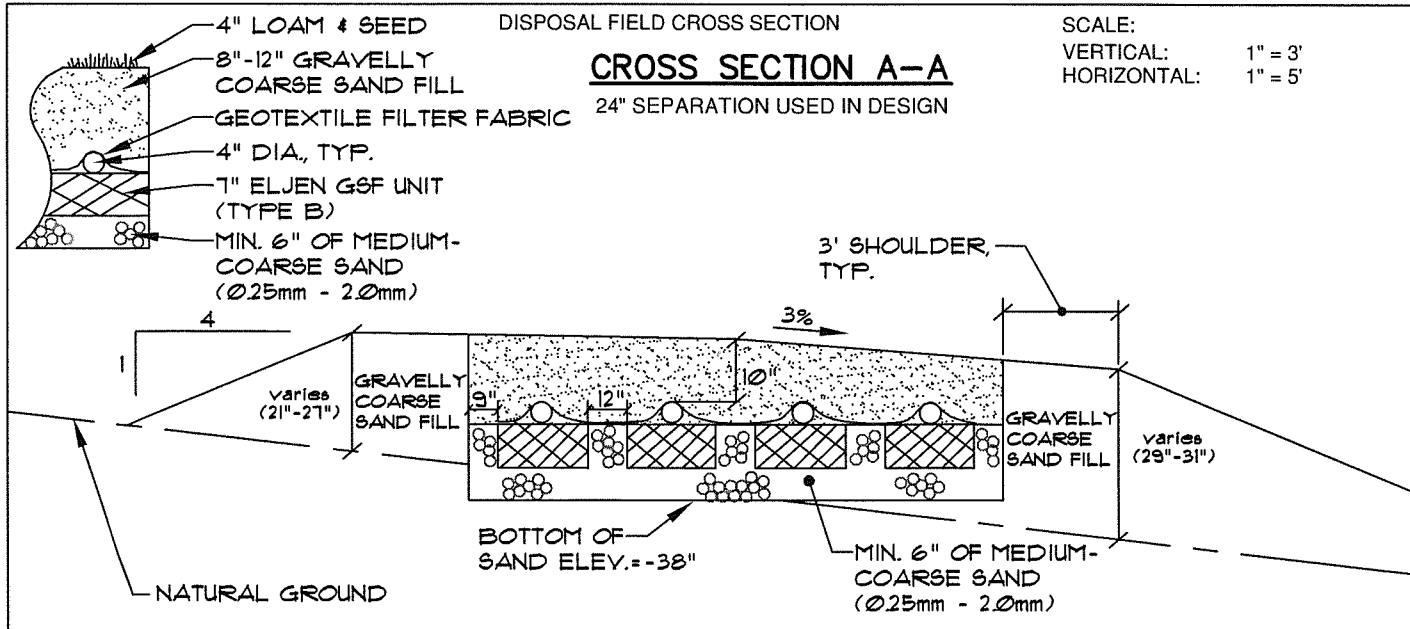

Site Evaluator Signature: *[Signature]* SE # 355 Date 3-15-16 Page 3 of 3 HHE-200 Rev. 02/11

General Notes
(attachment to form HHE-200)
<1,000 gpd Septic System

1. The nature of the site evaluation profession is one of interpretation of soil and site conditions. We, in the field, attempt to both provide a satisfactory service to the client, and comply by the rules by which we are bound - The Maine Subsurface Wastewater Disposal Rules. If at any time you, the client, are not satisfied with the service provided or the results found, it is your right to hire another site evaluator for a second opinion.
2. Property information is supplied by the owner, applicant or representative. Such information presented herein shall be verified as correct by the owner or applicant prior to signing this application.
3. All work shall be in accordance with the Maine Subsurface Wastewater Disposal Rules dated 1/18/11, as amended.
4. All work on the disposal field should be performed under dry conditions.
5. No vehicular or equipment traffic to be allowed on disposal area unless H-20 load is specified. Disposal field shall be constructed from outside the corner stakes located in the field. The downslope area is also to be protected in the same manner.
6. Backfill, if required, is to be gravelly coarse sand texture and to be free of foreign debris (per Table 11A of the Maine Subsurface Wastewater Disposal Rules). If backfill is coarser than original soil, then mix a minimum of 4" of backfill material into original soil.
7. No neighboring wells are apparent (unless so indicated) within 100' of disposal area. Owner or applicant shall verify this prior to signing the application.
8. The disposal field stone shall be clean, uniform in size and free of fines, dust, ashes, or clay. It shall have a nominal size of ¾" or 1½" (per Table 11B of the Maine Subsurface Wastewater Disposal Rules).
9. Minimum separation distances required (unless reduced by variance or special circumstance).
 - a) wells with water usage of 2000 or more gpd or public water supply wells:

Disposal Fields:	300'
Treatment Tanks:	150'
 - b) potable water supply to disposal field: 100'
 - c) potable water supply to treatment tank: 50'
 - d) treatment tank or disposal field to lake, river, stream or brook: 100' for major watercourse,
50' for minor watercourse
 - e) house to treatment tank: 8'
 - f) house to disposal field: 20'
 - For all other separation distances, use separations for less than 1,000 gpd per Maine Subsurface Wastewater Disposal Rules Table 7B for first-time systems and Table 8A for replacement systems.
10. Location of septic system near a wetland may require a separate permit. As such, the owner, prior to construction of the septic system, shall hire a professional to evaluate proximity of adjacent wetlands and prepare necessary permit applications.
11. Garbage disposals are not recommended and, if installed, are done so at the owner's risk. The additional waste load requires increased maintenance frequency and may cause premature failure of disposal field.
12. Pump stations, when required, shall be installed watertight to prevent infiltration of ground and/or surface water.
13. Force mains and pressure lines shall be flushed of any foreign material and pumps shall be checked for proper on/off cycle before being put into service.
14. Force mains, pump stations, and/or gravity piping subject to freezing shall be installed below frost line or adequately insulated.

APPENDIX B

SAFTEY REQUIREMENTS

(This page left intentionally blank)

PLAZA SAFETY REQUIREMENTS
YORK TOLL PLAZA
(MM 8.8)

The following are the minimum Plaza Lane closure requirements for completing the work. The limits have been set to protect Turnpike patrons and Toll Attendants from potential harm during the construction. The Contractor shall utilize this information in bidding the work. Drums and constructions signs will be paid under their respective pay items. Movement of drums and construction signs will be paid under the Maintenance of Traffic pay item.

The Contractor shall furnish, erect, maintain and relocate twenty 10 inch by 14 inch (minimum dimensions) DANGER – Unauthorized Persons Keep Out, or DANGER – DO NOT ENTER signs, meeting OSHA specifications for size, color and legend, for installation on toll booths or drums, as directed by the Resident. The Contractor shall furnish and install red hazard safety tape between barrels and in cordoned off tunnel and lane areas to identify the hazard areas for Turnpike patrons and Toll Attendants. The purchase, erection, maintenance, and relocation of the hazard signs and hazard safety tape shall be incidental to the mobilization pay item. Providing, maintaining and relocating the specified plywood safety walkways at all locations shall also be incidental to the mobilization pay item.

Unless otherwise specified all labor, materials and equipment required to meet the requirements of Appendix C shall be incidental to the various pay items. Maintenance of Traffic signing shall be in place during plaza work at all times.

(This page left intentionally blank)

APPENDIX C

DEFINED TERMS

(This page left intentionally blank)

DEFINED TERMS

- AVI (Automatic Vehicle Identification): a system consisting of an antenna and reader installed in a toll lane for communication with a transponder located on a vehicle for automatic identification of the transponder as it passes through the lane.
- Canopy Override Switch (COS): shall mean the switch that controls the signal that is located on the canopy on the entry side of each toll lane.
- Sensor Loops: a system for automatic vehicle detection, separation and classification.
- COMM - Communications
- Components: parts that compose a device or piece of equipment.
- DVAS (Digital Video Audit System) – A video camera and image storage system that captures traffic movements in the lane 24 hours a day.
- EMT - Electrical Metallic Tubing
- Gradient Sensor – Part of the Sensor Loop system - a gradient sensor is placed on each side of the Primary sensor.
- Contractor: the Contractor hired by the Authority through a solicitation process to complete the Project.
-
- JB - Junction Box
- Lane Controller (LC): A computer system for each type of toll lane that controls the lane equipment.
- Manual Lane Terminal (or MLT): A device consisting of an array of touch screen buttons and associated electronics for processing toll transactions in the attended tollbooths.
- MTA - Maine Turnpike Authority
- NTS -Not to Scale
- Paypoint Sensor – Part of the Sensor Loop system. Detects when the vehicle has reached the lane paypoint, in this case the tollbooth door centerline.
- Primary Sensor – Part of the Sensor Loop system. Located between two gradient sensors, a 6' x 6' square sensor that participates in vehicle classification.
- Project: shall mean the upgrade of the existing New Gloucester Barrier Toll Lane 8 to the toll collection system described in herein.
- RMC - Rigid Metallic Conduit

- RP (Receipt Printer) – Receipt printer that communicates with the payment system. Located in the booth.
- Specifications: shall mean the Technical Specification and instructions included in this document for the purpose of defining the installation procedures
- SI (Systems Integrator) - The systems integrator/contractor for the MTA toll system.
- SS - Stainless Steel
- TCP (Traffic Control Pedestal): A pedestal to mount a traffic signal and screen with a message to patrons.
- UPS - Uninterrupted Power Supply
- VES (Violation Enforcement System) – Cameras that automatically capture digital photographic images of vehicles and their license plates.

APPENDIX D

PLAZA WORK CHECKLIST

(This page left intentionally blank)

PLAZA – WORK CHECKLIST

<u>DATE SUBMITTED:</u>		<u>DATE APPROVED:</u>				
<u>REVISION #1:</u>		<u>DATE APPROVED:</u>				
<u>REVISION #2:</u>		<u>DATE APPROVED:</u>				
PROPOSED EQUIPMENT	PROPOSED LOCATION	POWER SOURCE		EXTRA WORK (Y/N)	<u>APPRVL DATE</u>	<u>APPRVL BY</u>
		PANEL	CIRCUIT			
AVI READERS						
SENSOR LOOPS						
DVAS CAMERA MOUNTS						
ORT LANE CONTROLLER CABINETS						
VCARS CAMERAS						
OPUS SCANNERS						
AVI ANTENNAS						
LIGHTNING SUPPRESSION SYSTEMS						
SPACE FRAME LIGHTING SYSTEMS						
EXISTING TO REMAIN EQUIPMENT	LOCATION	POWER SOURCE		EXTRA WORK (Y/N)	<u>APPRVL DATE</u>	<u>APPRVL BY</u>
		PANEL	CIRCUIT			
UPS IN BUILDING						
EXISTING EQUIPMENT TO BE REMOVED	LOCATION	POWER SOURCE		EXTRA WORK (Y/N)	<u>APPRVL DATE</u>	<u>APPRVL BY</u>
		PANEL	CIRCUIT			
ENTRY LOOPS						
EXIT LOOPS						
TREADLES						
LIGHT CURTAIN						
PATRON FARE DISPLAY						
ISLAND TRAFFIC LIGHT						
OVERHEAD SCANNER						
CANOPY OVERRIDE SWITCH						
LANE USE SIGNAL						
RED LIGHTS						
AVI ANTENNAS						
PORTION OF LIGHTNING SUPPRESSION SYSTEM						
PORTION OF CANOPY LIGHTING						
EXPLANATION OF ALL EXTRA WORK (USE ADDITIONAL SHEET IF REQUIRED)						

(This page left intentionally blank)

APPENDIX E

PRODUCT DATA SHEETS

(This page left intentionally blank)

Costar CHG3000S Series

Weatherproof Environmental Enclosure



The CHG3000S Series environmental enclosures house 1/3-inch or 1/2-inch format CCD cameras. Side openings allow easy access to the removable camera sled. The weatherproof CHG3000S is designed for indoor and outdoor use and has a body length of 12.5 inches. These housings work with fixed focal length or small zoom lenses. Also available is a 24V heater/blower kit.

Product Features

- For 1/3-inch format CCD cameras
- All aluminum construction
- Side opening for easy access
- Designed for indoor/outdoor applications; for use with fixed mount or pan/tilt
- Dustproof, IP66 weatherproof rated

CHG3000S HOUSINGS

CHG3000S Series Specifications

Models

CHG3000S	Enclosure, environmental, 12.5-inch (31.75 cm) lower body length
CHG3000SHB	Enclosure, environmental, 12.5-inch (31.75 cm) lower body length. 24V thermostat controlled heater and blower

General

Maximum Camera and Lens Size	Accepts camera and lens combinations (including BNC connector) up to: CHG3000S 11.5" L x 3.5" W x 2.5" H (29.21 cm x 8.89 cm x 6.35 cm) CHG3000SHB 11.5" L x 3.5" W x 2.5" H (29.21 cm x 8.89 cm x 6.35 cm)
Window Size	.11-inch (3.0 mm) thick tempered glass 2.42" H x 2.65" W (6.15 cm x 6.75 cm)
Construction	Die-cast, extruded, and sheet aluminum
Finish	Light-gray polyester power coat
Camera Mounting	Removable camera sled with adjustable height
Housing Mounting	Two (2) 1/4-20 tapped holes
Cable Entry	Two .35-inch (9.0 mm) glands on rear of housing
Rear Locking	Located at rear of housing; available for security lock
Environment	Indoor/outdoor: -10°F to 120°F (-23.33°C to 48.89°C)
Weight	Unit Shipping
CHG3000S	2.70lb (1.23kg) 3.03lb (1.38kg)
CHG3000SHB	3.67lb (1.67kg) 4.18lb (1.90 kg)

Electrical

Input Voltage	24VAC, 50/60Hz lower body length
---------------	----------------------------------

Power Consumption

Heater	Heater activates ON at 42-58°F (6-14°C) and OFF at 72-88°F (22-31°C), 20W, 0.83 Amp
Blower	Blower activates ON at 77-93°F (25-34°C) and OFF at 62-78°F (17-26°C), 2W, 0.08 Amp

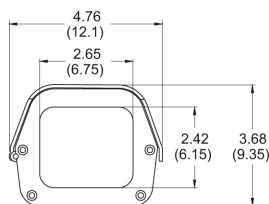

Optional Accessories

CHG3000-02	Heater kit, 24V, 20W, 0.83 Amp
CHG3000-03	Blower kit, 24V, 2W, 0.8 Amp

Note: Heater and Blower assemblies require O/I PCB BOARD assembly for connection.

Recommended Mounts

Wall CHG2700	Light duty wall mount. Max. load 20 lb (9.06kg)
Ceiling/Pedestal CHG2720	Medium duty ceiling "J" mount. Max. load 20 lb (9.06kg)

Design and specifications subject to change without notice.

Conversion: 1" = 25.4mm

Measurement conversions are approximate.

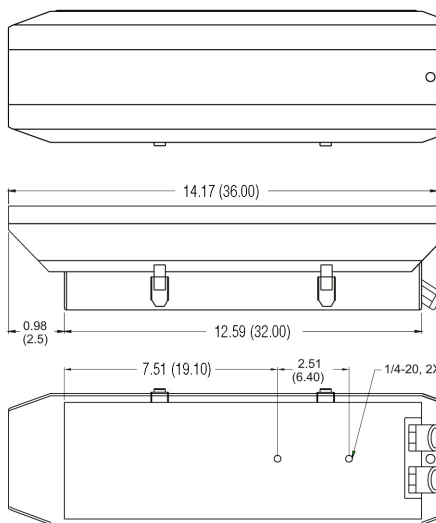

Unit: inch(cm)

CHG3000S HOUSINGS

EM1109/EM2000/EM2200 Mount

PIPE/POLE MOUNT, MEDIUM DUTY, ENCLOSURE

Product Features

- Low Cost
- Manually Adjustable Swivel Head
- Cable Feedthrough Hole
- Supports up to 40 lb (18.14 kg)
- Mounts on Vertical or Horizontal Pipe/Pole; Mounting Straps Included
- Compatible with Most Pelco Enclosures with a 2-Inch (5.08 cm) Mounting Pole Pattern

The **EM1109/EM2000/EM2200** are medium duty enclosure mounts designed for applications where mounting on a pipe or pole is necessary. These mounts can be used with Pelco enclosures having a 2-inch (5.08 cm) mounting hole pattern and are capable of supporting up to 40 lb (18.14 kg). All three mounts feature a manually adjustable swivel head and a cable feedthrough hole to conceal wiring. Multiple mounting holes on the tilt table provide maximum 360-degree horizontal positioning of the enclosure.

The **EM1109** is a pedestal mount for use on a horizontal or vertical pipe or pole. The **EM2000** is a J-type mount for use on a vertical pipe or pole, and the **EM2200** is a "hook" type mount for use on a horizontal pipe or pole. The **EM1109/EM2000/EM2200** must be mounted on pipes or poles having a 3-inch (7.62 cm) to 8-inch (20.32 cm) diameter. Mounts are secured to the pipe or pole with stainless steel mounting straps. Two 1/4-20 mounting bolts required to secure the enclosure to the mount are also supplied.

The **EM1109/EM2000/EM2200** are constructed of aluminum and have a white epoxy powder coat finish.



EM2200



EM2000

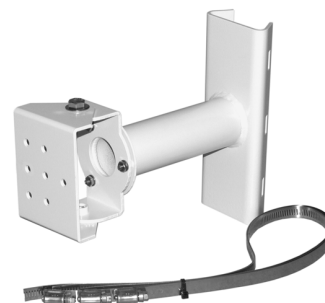

EM1109



TECHNICAL SPECIFICATIONS

MODELS

EM1109	Medium duty pedestal mount for horizontal or vertical pipe or pole applications. Manually adjustable swivel head and cable feedthrough hole.
EM2000	Medium duty 90 degree J-mount for vertical pipe or pole applications. Manually adjustable swivel head and cable feedthrough hole.
EM2200	Medium duty "hook" mount for horizontal pipe or pole applications. Manually adjustable swivel head and cable feedthrough hole.

MECHANICAL

Pan Adjustment	Unlimited 360°
Tilt Adjustment	±75°
Locking Method	3/8-16 hex head bolts (on manually adjustable swivel head)

GENERAL

Suggested Mounting Method	Slots provided for mounting straps; 3 stainless steel straps supplied. Straps fit 3-inch (7.62 cm) to 8-inch (20.32 cm) diameter pole.
Enclosure Mounting	2, 1/4-20 mounting bolts (supplied)
Maximum Load	40 lb (18.14 kg)
Construction	Aluminum
Finish	White epoxy polyester powder coat
Environment	Indoor/outdoor
Unit Weight	
EM1109	1.88 lb (0.85 kg)
EM2000	3.05 lb (1.38 kg)
EM2200	3.51 lb (1.59 kg)

Shipping Weight	
EM1109	3 lb (1.36 kg)
EM2000	8 lb (3.60 kg)
EM2200	9 lb (4.10 kg)

RECOMMENDED ENCLOSURES

Pelco enclosures having a 2-inch (5.08 cm) mounting hole pattern can be used with these mounts. Be sure the enclosure/camera/lens combination you select does not exceed 40 lb (18 kg) and is suitable for the type of mount you have selected. The following list indicates the most applicable enclosures.

- EH3010/EH3014 Series
- EH4010 EH4014 Series
- EH3508 Series, Environmental
- EH3512/EH3515 Series, Environmental
- EH4700 Series, Environmental
- EH4700DB Series, Environmental
- E700 Series, Dust-Tight
- EHX4E, Explosion-Proof
- EH8100 Series, Pressurized

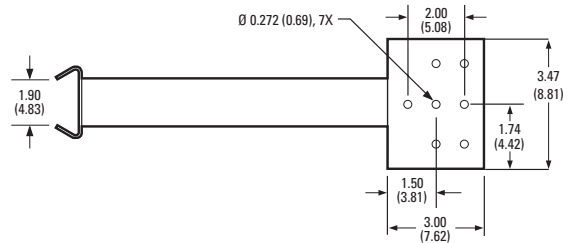

EM2000

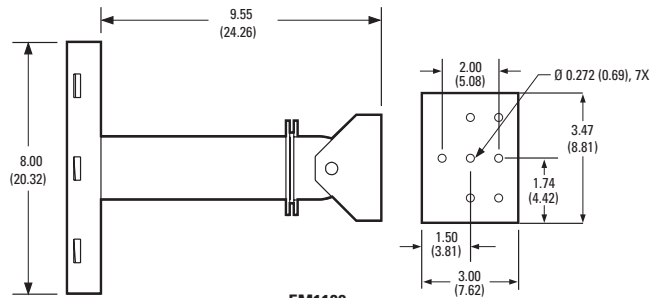

EM1109

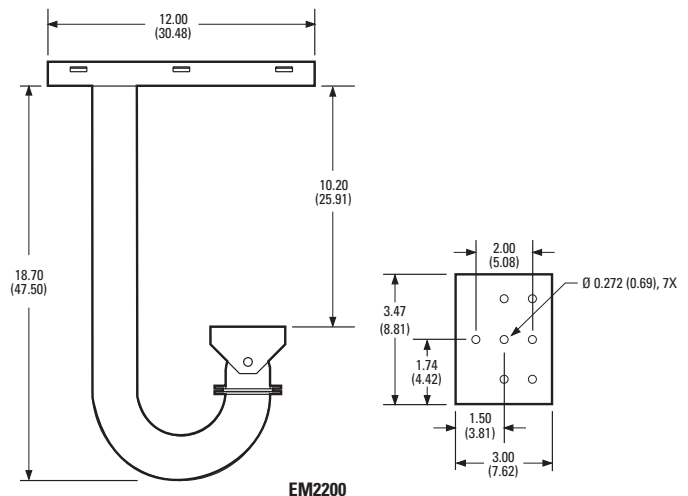

EM2200

NOTE: VALUES IN PARENTHESES ARE CENTIMETERS; ALL OTHERS ARE INCHES.



Pelco, Inc. Worldwide Headquarters:
 3500 Pelco Way, Clovis, California 93612-5699 USA
USA & Canada Tel: (800) 289-9100 • FAX: (800) 289-9150
International Tel: +1 (559) 292-1981 • FAX: +1 (559) 348-1120
www.pelco.com

Pelco and the Pelco logo are registered trademarks of Pelco, Inc.
 Product specifications and availability subject to change without notice.
 ©Copyright 2008, Pelco, Inc. All rights reserved.



112 RAILROAD ST., REVERE, MA 02151
(800) 420-0021; (781) 289-1400; (781) 289-1405 (FAX)
www.durantcorp.com

STAT-A-FLEX PRODUCT DATA SHEET

PRODUCT NAME: STAT-A-FLEX TRAFFIC LOOP SEALER
CHEMICAL FAMILY: UNSATURATED POLYESTER RESIN

PHYSICAL PROPERTIES:

BOILING POINT: 293°F (Styrene)
SPECIFIC GRAVITY: 1.25 +/- 0.15
VAPOR PRESSURE: (mm Hg) 5.2 (Styrene)
PERCENT VOLATILE BY WT : 18-22 %
VAPOR DENSITY (AIR=1): 3.6 (Styrene)
EVAPORATION RATE (Bu Ace=1): UK
SOLUBILITY IN WATER: Negligible
WEIGHT PER GALLON: Approx. 10.5 lbs
SHORE D HARDNESS @ 24HRS: 73 +/- 5
VISCOSITY: 104 KU
GEL TIME (@ 77 ° F): 10 – 20 min. [ASTM C881]
TACK FREE (@ 77 ° F): 15-25 min.
CURING TIME (@ 77 ° F): 45-60 min.
ELONGATION: 18 - 20 % [ASTM D638-96]
TENSILE STRENGTH: > 1000 psi [ASTM D638-96]
FLEXURAL STRENGTH: >1200 psi [ASTM D790]
ADHESION
Steel : 800 +/- 100 psi
Portland Cement: 300psi [ASTM D3163-84]
ABSORPTION 24 HOURS
Water: 0.2% [ASTM D570]
No. 3 Oil 0.02% [ASTM D570]
Gasoline 0.04% [ASTM D570]
Jet Fuel (Submersion No Dissolution) 0.06%
3% NaCl 0.2%

STAT-A-FLEX ADVANTAGES:

- Two part, component system, utilizing a liquid methyl ethyl ketone peroxide (MEKP) hardener.
- Bonds to all road surfaces
- Self leveling liquid / Pours fluidly
- Requires no special equipment, just mix and pour
- Cures in less than 20 minutes to produce a tough weather resistant seal
- Adjustable dry times regulated by amount of hardener (MEKP) added
- Totally encapsulates traffic detector loop wire
- Will not react with wire insulation
- Formulated to withstand stresses due to traffic vibrations
- Resistant to cracking caused by expansion and contraction due to temperature changes
- Resistant to most chemicals and solvents including road salts, acids, hydrocarbons, brake fluids, oils, gasoline and jet fuel
- Available in 1 Gal., 3.5 Gal., and 5 Gal. pails

STAT-A-FLEX Application Instructions:

- For best results STAT-A-FLEX should be mixed with a powered mixer
- Mix for one minute, then pour in desired amount of hardener and mix for two minutes
- Pour STAT-A-FLEX into saw cut to be filled (It's that easy!)
- Hardener component amounts may be adjusted according to temperature
- An ACCELERATOR is also available for use in colder climates to further reduce drying time
- NOTE: Improper mixing may cause poor results

STAT-A-FLEX Storage and Shelf Life:

- Best if stored at temperatures under 80 °F
- Shelf life of 12 months (unopened)

Direct-View LED Traffic Controller DOT2424RG-175

PRODUCT NUMBER

5651



CABINET DIMENSIONS

24" H x 24" W x 5" D

ILLUMINATION SOURCE

Super bright, narrow viewing angle LEDs
Available in green, red, blue, amber, and white LEDs
Messages "blankout" when turned off, eliminating confusion
Long life, solid state lighting

ELECTRICAL

Integrated solid state power supply
Photocell for auto phototrimming
Standard Voltage: 120 VAC, Optional Voltages: 9-36 V, 240 VAC, 277 VAC
Maximum amps per lighted message (at 120 V) shown in the table below
UL/CUL approved for wet locations

CONSTRUCTION

Faces: Single Faced Sign
Cabinet: (DOT) NEMA 4X Rated, 1/8" wall T5052 aluminum cabinet with continuously welded seams. Optional Visor
Door: Continuous hinge with a 1" x 1/4" silicone gasket and stainless steel tool free door latches
Face Material: impact resistant, 1/4" thick smoke tinted polycarbonate

FINISH

Standard Cabinet Color: Black
Custom colors available upon request

MESSAGE	COLOR	HEIGHT	AMPS
X	30° Red Round	18.0"	0.17
Down Arrow	30° Green Round	18.0"	0.13

Trans-Tech

4999 Pittsburgh Ave.
Erie, PA 16509
Phone: (888) 811-7010
Fax: (814) 836-8401
Email: sales@transportation-tech.com
Website: www.transportation-tech.com



Proudly Made in the USA

Product View

NOTE: Sign image may not exactly represent the finished product. For illustration purposes only.

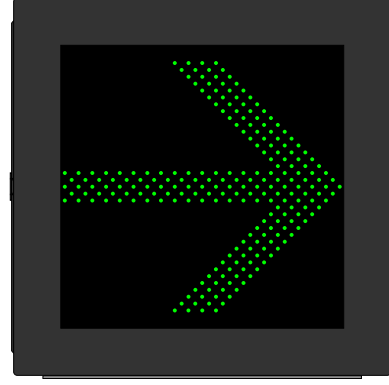
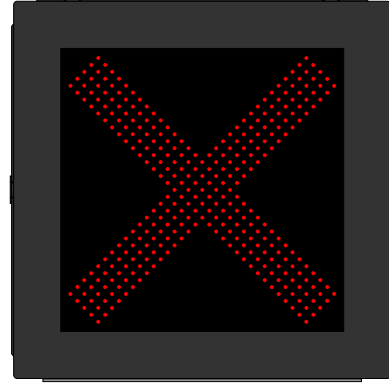
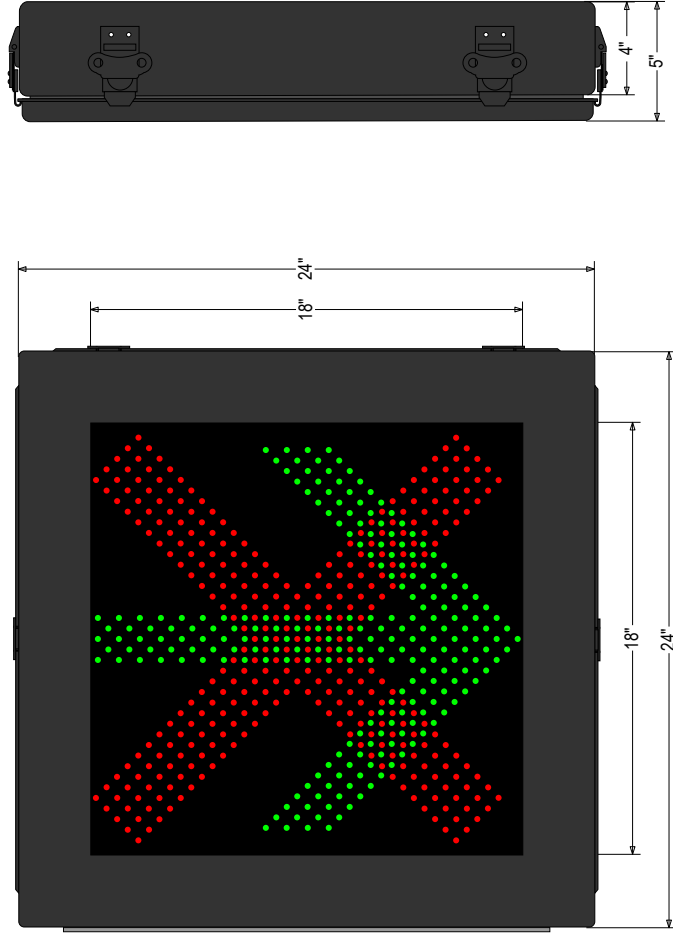

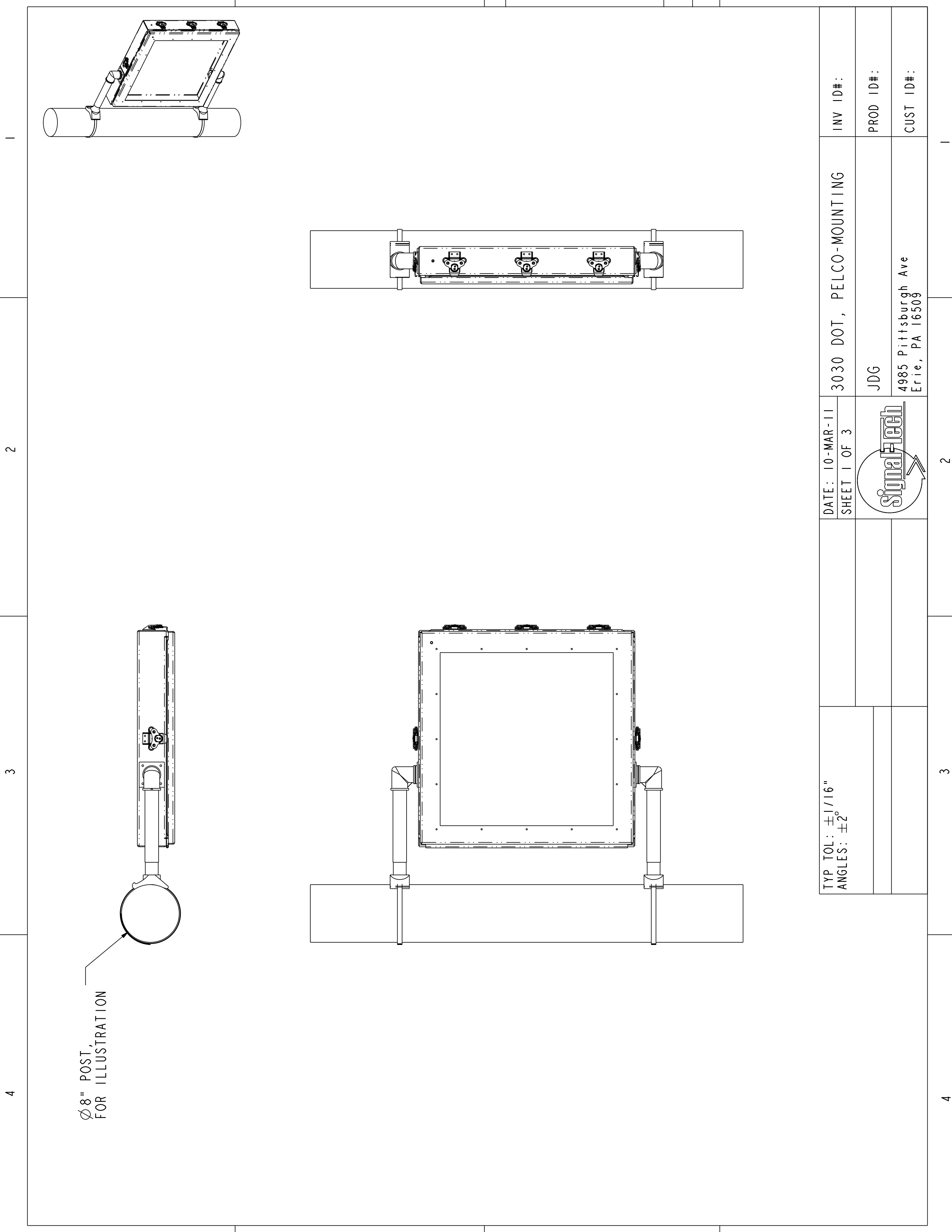

Ø8" POST,
FOR ILLUSTRATION

TYP TOL: $\pm 1/16"$
 ANGLES: $\pm 2^\circ$

DATE: 10-MAR-11
 SHEET 1 OF 3

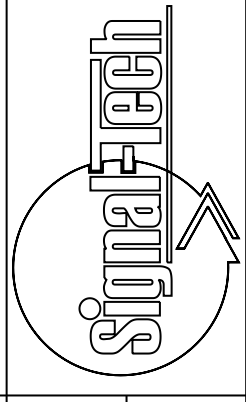

3030 DOT, PELCO-MOUNTING

JDG
 4985 Pittsburgh Ave
 Erie, PA 16509

INV ID#:

PROD ID#:

CUST ID#:

4 3 2 1

D C B A

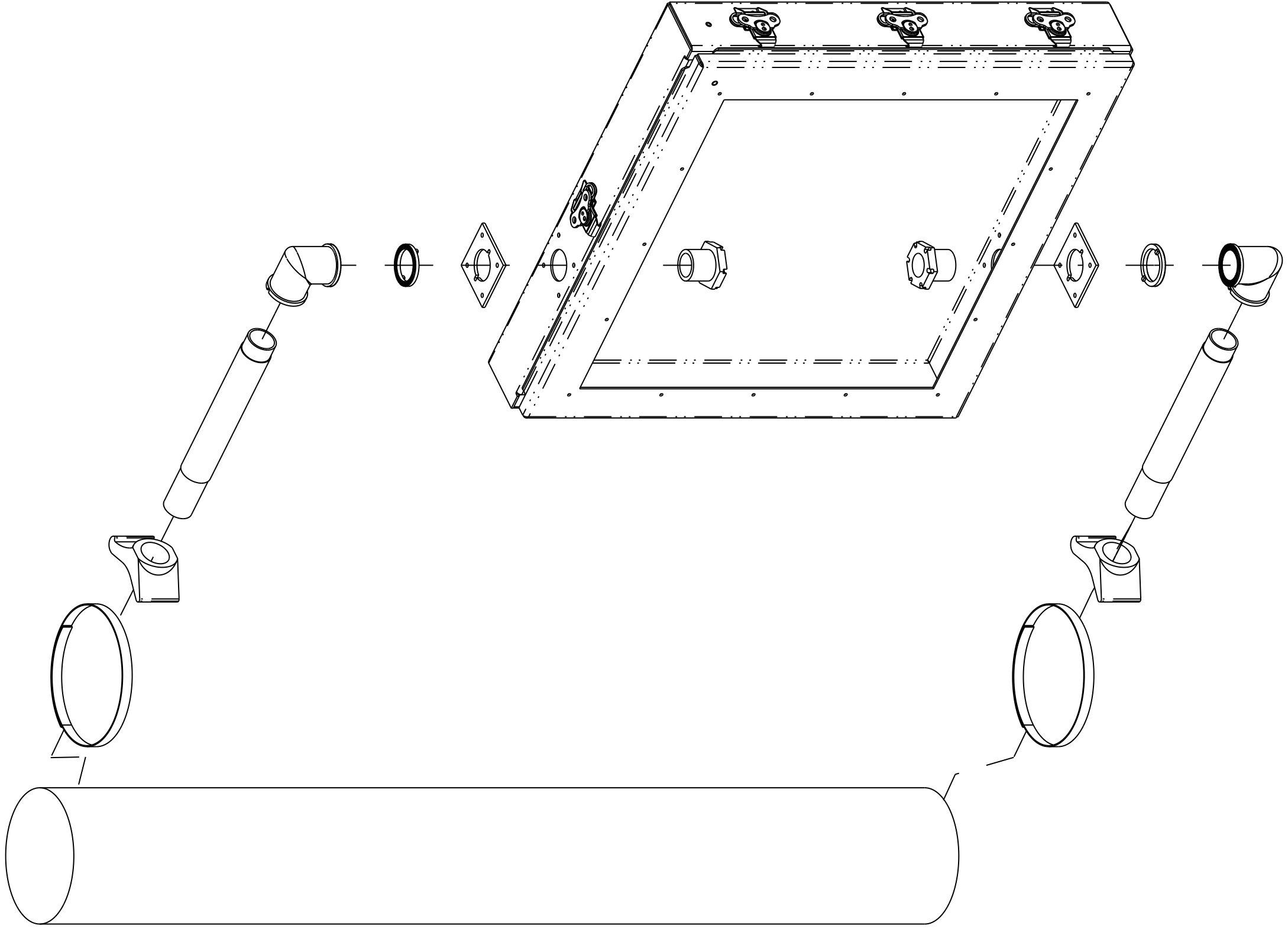

TYP TOL: $\pm 1/16"$
 ANGLES: $\pm 2^\circ$

DATE: 10-MAR-11
 SHEET 2 OF 3

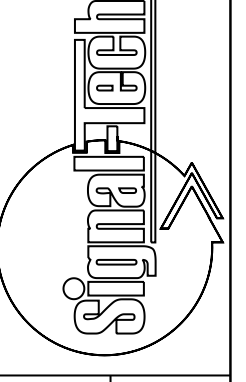

3030 DOT, PELCO-MOUNTING

JDG
 4985 Pittsburgh Ave
 Erie, PA 16509

INV ID#:

PROD ID#:

CUST ID#:

1

2

3

4

D

C

A

D

C

AP - 30

B

A

1

2

3

4

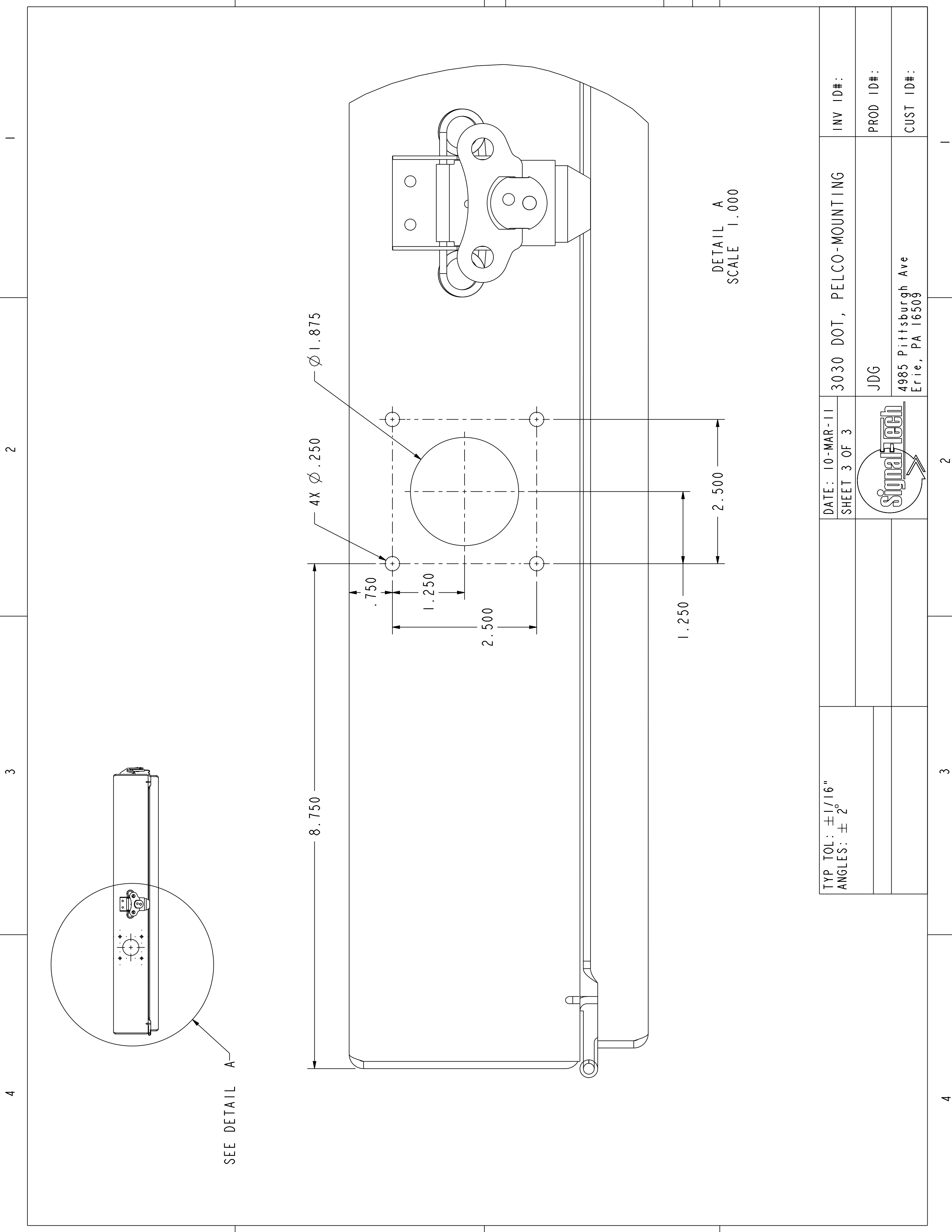

DETAIL A
SCALE 1.000

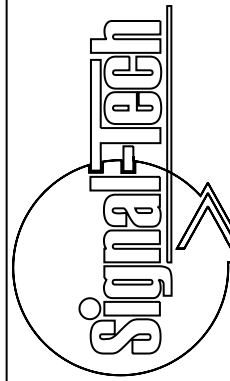
TYP TOL: $\pm 1/16"$ ANGLES: $\pm 2^\circ$	DATE: 10-MAR-11	3030 DOT, PELCO-MOUNTING	INV ID#:
	SHEET 3 OF 3	JDG	PROD ID#:
			CUST ID#:
	4985 Pittsburgh Ave Erie, PA 16509		

Vanguard® VS-5220 VSLS

Daktronics Vanguard® VS-5220 variable speed limit signs (VSLS) are designed to be an integrated, enforceable, and affordable part of a traffic management system. The signs provide high legibility 18-inch digits that are easily changed as traffic and weather conditions change.

The VS-5220 features an active LED speed limit pixel matrix and surrounding reflective 48-inch wide by 60-inch tall MUTCD-compliant static panel. The high-resolution LED pixel matrix allows clearly formed black digits on a white background that approximate the E-series fonts specified by the MUTCD. In freeway situations, the signs are nearly indistinguishable from static signs. All of this makes them more easily enforced than the amber VSLS seen in the market today.

The signs use a blend of long-life red, green, and blue LEDs to create the white light used for the speed limit background. An integrated light sensor automatically adjusts the LED intensity for all ambient lighting levels. Under full sunlight, the LEDs match the reflectivity of the surrounding speed limit panel. At night, the LEDs dim to a very legible level that will not blind drivers and is not washed out by headlights. Our long-life LED technology is designed for a 100,000 hour life and consumes less than 150 watts at full intensity.

The VS-5220 is designed for the roadside environment and features a number of features typically found only in high-end variable message signs (VMS). A forced-air ventilation system provides filtered air to keep the sign cool. Pixel diagnostics allow remote monitoring of the sign to ensure legibility, and the internal controller and mounting location for communication equipment eliminates the need for costly traffic cabinets.

The VS-5220 features a powerful NTCIP-compliant controller that integrates into nearly any traffic management system. The posted speed limit can be scheduled or controlled manually. The built-in logging function keeps track of all speed limit changes. Daktronics offers Vanguard software, which can control, configure, and monitor the VSLS, as well as any other NTCIP-compliant DMS.

The Vanguard VS-5220 VSLS are the best choice for a speed management solution. The signs offer the features needed, and allow integration into any NTCIP-compatible traffic management system.



Vanguard® VS-5220 VSLS

Key Features

Dynamic Sign Panel

- Programmable matrix capable of two - 18-inch (473 mm) speed digits
- Black digits on white background
- Legible from greater than 1000 ft (305 m)
- High-intensity LED technology
- Wide 30-degree LED viewing angle
- Minimum brightness of 12,400 cd/m²
- Pixel self-diagnostics ensure legibility
- Contrast-enhancing louvers shield pixels from sunlight
- Built-in pixel diagnostics monitor LED operation
- Automatic brightness control using integrated light sensor

Static Sign Panel

- 48-inch by 60-inch aluminum panel
- MUTCD-compliant
- Reflective white 3M sheeting

Cabinet Style

- Lightweight all-aluminum cabinet construction
- Front service access cabinet for easy maintenance
- Forced-air, filtered ventilation system keeps sign cool
- Mounts to existing poles (hardware not included)

Control System & Diagnostics

- Internal NTCIP-compliant controller
- Automatic speed change logging
- Manual or scheduled speed control
- Available Vanguard control software

Specifications

Dynamic Sign Panel Specifications

- Pixel Matrix: 16 rows by 24 columns
- Pixel Pitch: 1.33 in (34 mm)
- Default Font Size: 14 rows by 10 columns
- Active Area: 1'9" H x 2'8" W (544 mm x 816 mm)

Static Sign Panel Specifications

- MUTCD-compliant speed limit panel
- 60" H x 48" W (1.52 m x 1.22 m) panel
- Reflective white 3M sheeting with black E-series lettering

Physical Specifications

- Speed Limit Panel Size: 60" H x 48" W (1.52 m x 1.22 m)
- Sign Cabinet Size: 27" H x 35" W x 6" D (686 mm x 889 mm x 152 mm)
- Sign Weight: 100 lbs (45.4 kg)
- Operating Temperature Range: -40° F to +140° F (-40° C to +60° C)
- Humidity Range: 0 to 99%, non-condensing
- 120 VAC single-phase power (2 wires plus ground)
- Max Power: 197 watts
- Typical Power: 145 watts

Controller Specifications

- NTCIP-compatible controller
- Compatible with dial-up, cellular, fiber, Ethernet, radio, RS-232, RS-422, and other communication devices
- Controller mounted within cabinet
- Internal mounting shelf for communication equipment

Design and Manufacturing Standards

- NTCIP-compliant control system
- Designed to AASHTO wind-load requirements
- Welders certified to AWS D1.2
- NEMA 3R cabinet rating

NTCIP Communication Standards

- NTCIP 1203 – DMS Objects
- NTCIP 1201 – Global Objects
- NTCIP 1101 – STMF
- NTCIP 2101 – PMPP/RS-232
- NTCIP 2103 – PPP/RS-232
- NTCIP 2104 – Ethernet
- NTCIP 2202 – TCP/IP
- NTCIP 2301 – STMF

Daktronics VSLs versus Static Sign



Vanguard® VS-5220 VSLs



Static Speed Limit Sign



VANGUARD® VL-35X0 DISPLAY

LOUVERED FACE, FRONT ACCESS DMS

The Daktronics Vanguard® VL-35X0 dynamic message sign (DMS) is an NTCIP-compliant solution for applications requiring a light-weight package with an extended viewing angle. The VL-35X0 DMS combines Daktronics quality with fundamental functionality to inform travelers in many ITS applications.

Featuring an innovative high-contrast full-matrix design, the VL-35X0 provides legibility ideal for locations such as arterial roads and toll booths. The sign's modular design allows it to be built in many sizes. A 70-degree viewing cone and a 6-inch minimum character height add versatility to the VL-35X0. Available in amber or full color, the display's full-matrix configuration creates larger characters and graphics.

FEATURES AND BENEFITS

- Lightweight, quick-detach modules for easy front-side access to components
- Durable louvers enhance contrast, optimize brightness, eliminate glare and allow a wide viewing angle
- Continually-cooling, forced-air ventilation for increased DMS longevity
- Available in amber and full color models
- Internal NTCIP-compliant controller built for reliability
- Integrates with Ethernet (wire or fiber) and RS422 serial

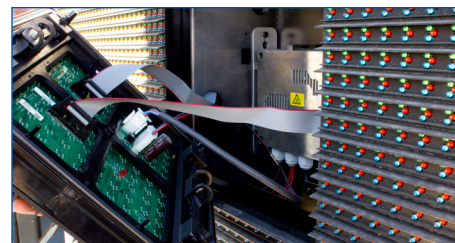

Front-access, louvered-face design

TECHNICAL SPECIFICATIONS

Pixel pitch	20mm center-to-center
Character height	6-inch standard character height
Color capability	Monochrome (amber) or full color
Full Color Brightness	9,500 cd/m ² maximum
Amber Brightness	5,500 cd/m ² maximum
Estimated LED lifetime	100,000+ hours
Viewing cone	70°
Service access	Front access
Control software	Vanguard v4 control software
Power	120 or 240 VAC single phase
Operating temperature	-40° F to +120° F (-40° C to +50° C)
Humidity range	0 to 95%, non-condensing
Display dimming	Automatic dimming 0-100%
Communication options	Cellular, Ethernet (wire or fiber)
Compliance information	NTCIP v2, UL, FCC and NEC



Power and Signal

MODEL NUMBER GUIDE

VL-35X0-16x48-20-A

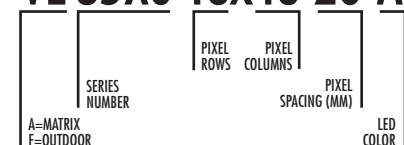

VANGUARD® VL-35X0 MODEL SPECIFICATIONS

MODEL NUMBER	APPROX. CABINET DIMENSIONS		LINES/ CHAR. WIDE	WEIGHT		MAX. POWER	
	FEET AND INCHES (HxWxD)	METERS		LBS.	K	AMBER	RGB
VL-35X0-16x48-20-A or RGB	1'9" x 3'8" x 8"	.52 x 1.11 x .21	2/9	60	28	220 W	260 W
VL-35X0-16x64-20-A or RGB	1'9" x 4'9" x 8"	.52 x 1.43 x .21	2/12	70	32	250 W	300 W
VL-35X0-16x80-20-A or RGB	1'9" x 5'9" x 8"	.52 x 1.74 x .21	2/16	80	37	310 W	380 W
VL-35X0-16x96-20-A or RGB	1'9" x 6'9" x 8"	.52 x 2.06 x .21	2/19	100	46	340 W	420 W
VL-35X0-16x112-20-A or RGB	1'9" x 7'10" x 8"	.52 x 2.38 x .21	2/22	110	50	360 W	460 W
VL-35X0-16x128-20-A or RGB	1'9" x 8'10" x 8"	.52 x 2.70 x .21	2/25	130	59	390 W	500 W
VL-35X0-16x144-20-A or RGB	1'9" x 9'11" x 8"	.52 x 3.01 x .21	2/29	140	64	450 W	570 W
VL-35X0-16x160-20-A or RGB	1'9" x 10'11" x 8"	.52 x 3.33 x .21	2/32	160	73	480 W	610 W
VL-35X0-16x176-20-A or RGB	1'9" x 12'0" x 8"	.52 x 3.65 x .21	2/35	170	78	540 W	690 W
VL-35X0-16x192-20-A or RGB	1'9" x 13'0" x 8"	.52 x 3.96 x .21	2/38	180	82	570 W	730 W
VL-35X0-16x208-20-A or RGB	1'9" x 14'1" x 8"	.52 x 4.28 x .21	2/41	200	91	590 W	770 W
VL-35X0-16x224-20-A or RGB	1'9" x 15'1" x 8"	.52 x 4.60 x .21	2/44	210	96	620 W	810 W
VL-35X0-16x240-20-A or RGB	1'9" x 16'2" x 8"	.52 x 4.91 x .21	2/48	230	105	680 W	880 W
VL-35X0-16x256-20-A or RGB	1'9" x 17'2" x 8"	.52 x 5.23 x .21	2/51	240	109	710 W	930 W
VL-35X0-32x48-20-A or RGB	2'9" x 3'8" x 8"	.84 x 1.11 x .21	4/9	90	41	300 W	390 W
VL-35X0-32x64-20-A or RGB	2'9" x 4'9" x 8"	.84 x 1.43 x .21	4/12	110	50	390 W	500 W
VL-35X0-32x80-20-A or RGB	2'9" x 5'9" x 8"	.84 x 1.74 x .21	4/16	130	59	480 W	610 W
VL-35X0-32x96-20-A or RGB	2'9" x 6'9" x 8"	.84 x 2.06 x .21	4/19	160	73	530 W	700 W
VL-35X0-32x112-20-A or RGB	2'9" x 7'10" x 8"	.84 x 2.38 x .21	4/22	180	82	620 W	810 W
VL-35X0-32x128-20-A or RGB	2'9" x 8'10" x 8"	.84 x 2.70 x .21	4/25	200	91	680 W	900 W
VL-35X0-32x144-20-A or RGB	2'9" x 9'11" x 8"	.84 x 3.01 x .21	4/29	230	105	730 W	980 W
VL-35X0-32x160-20-A or RGB	2'9" x 10'11" x 8"	.84 x 3.33 x .21	4/32	250	114	820 W	1,090 W
VL-35X0-32x176-20-A or RGB	2'9" x 12'0" x 8"	.84 x 3.65 x .21	4/35	270	123	910 W	1,210 W
VL-35X0-32x192-20-A or RGB	2'9" x 13'0" x 8"	.84 x 3.96 x .21	4/38	300	137	960 W	1,290 W
VL-35X0-32x208-20-A or RGB	2'9" x 14'1" x 8"	.84 x 4.28 x .21	4/41	320	146	1,050 W	1,400 W
VL-35X0-32x224-20-A or RGB	2'9" x 15'1" x 8"	.84 x 4.60 x .21	4/44	340	155	1,110 W	1,490 W
VL-35X0-32x240-20-A or RGB	2'9" x 16'2" x 8"	.84 x 4.91 x .21	4/48	370	168	1,200 W	1,600 W
VL-35X0-32x256-20-A or RGB	2'9" x 17'2" x 8"	.84 x 5.23 x .21	4/51	390	177	1,250 W	1,690 W
VL-35X0-48x48-20-A or RGB	3'10" x 3'8" x 8"	1.15 x 1.11 x .21	6/9	120	55	420 W	540 W
VL-35X0-48x64-20-A or RGB	3'10" x 4'9" x 8"	1.15 x 1.43 x .21	6/12	150	69	500 W	700 W
VL-35X0-48x80-20-A or RGB	3'10" x 5'9" x 8"	1.15 x 1.74 x .21	6/16	180	82	650 W	850 W
VL-35X0-48x96-20-A or RGB	3'10" x 6'9" x 8"	1.15 x 2.06 x .21	6/19	210	96	730 W	1,010 W
VL-35X0-48x112-20-A or RGB	3'10" x 7'10" x 8"	1.15 x 2.38 x .21	6/22	250	114	820 W	1,170 W
VL-35X0-48x128-20-A or RGB	3'10" x 8'10" x 8"	1.15 x 2.70 x .21	6/25	280	128	900 W	1,290 W
VL-35X0-48x144-20-A or RGB	3'10" x 9'11" x 8"	1.15 x 3.01 x .21	6/29	310	141	1,020 W	1,450 W
VL-35X0-48x160-20-A or RGB	3'10" x 10'11" x 8"	1.15 x 3.33 x .21	6/32	340	155	1,130 W	1,600 W
VL-35X0-48x176-20-A or RGB	3'10" x 12'0" x 8"	1.15 x 3.65 x .21	6/35	370	168	1,250 W	1,760 W
VL-35X0-48x192-20-A or RGB	3'10" x 13'0" x 8"	1.15 x 3.96 x .21	6/38	410	186	1,360 W	1,910 W
VL-35X0-48x208-20-A or RGB	3'10" x 14'1" x 8"	1.15 x 4.28 x .21	6/41	440	200	1,450 W	2,070 W
VL-35X0-48x224-20-A or RGB	3'10" x 15'1" x 8"	1.15 x 4.60 x .21	6/44	470	214	1,530 W	2,190 W
VL-35X0-48x240-20-A or RGB	3'10" x 16'2" x 8"	1.15 x 4.91 x .21	6/48	500	227	1,620 W	2,350 W
VL-35X0-48x256-20-A or RGB	3'10" x 17'2" x 8"	1.15 x 5.23 x .21	6/51	530	241	1,700 W	2,480 W
VL-35X0-64x48-20-A or RGB	4'10" x 3'8" x 8"	1.47 x 1.11 x .21	8/9	150	69	530 W	670 W
VL-35X0-64x64-20-A or RGB	4'10" x 4'9" x 8"	1.47 x 1.43 x .21	8/12	190	87	650 W	830 W
VL-35X0-64x80-20-A or RGB	4'10" x 5'9" x 8"	1.47 x 1.74 x .21	8/16	230	105	820 W	1,030 W
VL-35X0-64x96-20-A or RGB	4'10" x 6'9" x 8"	1.47 x 2.06 x .21	8/19	270	123	930 W	1,200 W
VL-35X0-64x112-20-A or RGB	4'10" x 7'10" x 8"	1.47 x 2.38 x .21	8/22	310	141	1,080 W	1,390 W
VL-35X0-64x128-20-A or RGB	4'10" x 8'10" x 8"	1.47 x 2.70 x .21	8/25	350	159	1,190 W	1,560 W
VL-35X0-64x144-20-A or RGB	4'10" x 9'11" x 8"	1.47 x 3.01 x .21	8/29	390	177	1,330 W	1,730 W
VL-35X0-64x160-20-A or RGB	4'10" x 10'11" x 8"	1.47 x 3.33 x .21	8/32	430	196	1,480 W	1,920 W
VL-35X0-64x176-20-A or RGB	4'10" x 12'0" x 8"	1.47 x 3.65 x .21	8/35	480	218	1,620 W	2,120 W
VL-35X0-64x192-20-A or RGB	4'10" x 13'0" x 8"	1.47 x 3.96 x .21	8/38	520	236	1,760 W	2,290 W
VL-35X0-64x208-20-A or RGB	4'10" x 14'1" x 8"	1.47 x 4.28 x .21	8/41	560	255	1,910 W	2,460 W
VL-35X0-64x224-20-A or RGB	4'10" x 15'1" x 8"	1.47 x 4.60 x .21	8/44	600	273	2,020 W	2,620 W
VL-35X0-64x240-20-A or RGB	4'10" x 16'2" x 8"	1.47 x 4.91 x .21	8/48	640	291	2,160 W	2,820 W
VL-35X0-64x256-20-A or RGB	4'10" x 17'2" x 8"	1.47 x 5.23 x .21	8/51	680	309	2,270 W	3,020 W
VL-35X0-80x48-20-A or RGB	5'11" x 3'8" x 8"	1.78 x 1.11 x .21	10/9	180	82	590 W	790 W
VL-35X0-80x64-20-A or RGB	5'11" x 4'9" x 8"	1.78 x 1.43 x .21	10/12	230	105	730 W	1,000 W
VL-35X0-80x80-20-A or RGB	5'11" x 5'9" x 8"	1.78 x 1.74 x .21	10/16	280	128	900 W	1,270 W
VL-35X0-80x96-20-A or RGB	5'11" x 6'9" x 8"	1.78 x 2.06 x .21	10/19	330	150	1,040 W	1,480 W
VL-35X0-80x112-20-A or RGB	5'11" x 7'10" x 8"	1.78 x 2.38 x .21	10/22	380	173	1,180 W	1,690 W
VL-35X0-80x128-20-A or RGB	5'11" x 8'10" x 8"	1.78 x 2.70 x .21	10/25	430	196	1,350 W	1,890 W
VL-35X0-80x144-20-A or RGB	5'11" x 9'11" x 8"	1.78 x 3.01 x .21	10/28	480	218	1,490 W	2,130 W
VL-35X0-80x160-20-A or RGB	5'11" x 10'11" x 8"	1.78 x 3.33 x .21	10/32	530	241	1,630 W	2,370 W
VL-35X0-80x176-20-A or RGB	5'11" x 12'0" x 8"	1.78 x 3.65 x .21	10/35	580	264	1,800 W	2,610 W
VL-35X0-80x192-20-A or RGB	5'11" x 13'0" x 8"	1.78 x 3.96 x .21	10/38	630	286	1,940 W	2,850 W
VL-35X0-80x208-20-A or RGB	5'11" x 14'1" x 8"	1.78 x 4.28 x .21	10/41	680	309	2,080 W	3,060 W
VL-35X0-80x224-20-A or RGB	5'11" x 15'1" x 8"	1.78 x 4.60 x .21	10/44	730	332	2,220 W	3,270 W
VL-35X0-80x240-20-A or RGB	5'11" x 16'2" x 8"	1.78 x 4.91 x .21	10/48	780	354	2,430 W	3,470 W
VL-35X0-80x256-20-A or RGB	5'11" x 17'2" x 8"	1.78 x 5.23 x .21	10/51	830	377	2,600 W	3,680 W

NOTE

Because Daktronics continuously improves its products, all of the specifications on this document are subject to change without notice. Please contact Daktronics for the most current specifications.

Nominal character heights and number of lines that fit on each DMS are calculated using 7-pixel-high fonts. Many other font sizes are available.

Contact Daktronics for details about other fonts.

117 Prince Drive PO Box 5120
Brookings, SD 57006
tel 605-697-4061
toll free 888-325-8726
www.daktronics.com
transportation@daktronics.com
Copyright © 2013 Daktronics
DD1652066 Rev 03 042913



DAKTRONICS

DM-100 Console ■ DataMaster 2000 Series

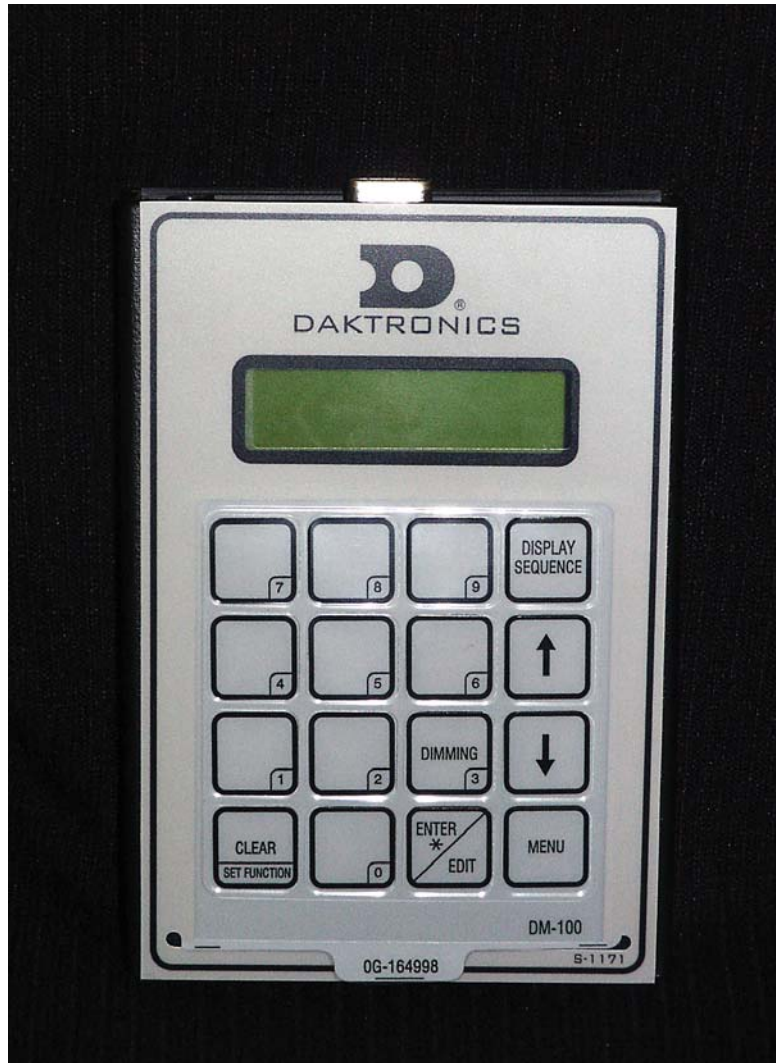

Above: DM-100 Console

Technical Specifications

Dimensions:

Height 6", Width 4", Depth 1.25
(152 mm, 103 mm, 32 mm)

Weight:

.5 lb (.2268 kg)

Power:

2 W maximum, 12 V AC

LCD Viewing Area:

Height .625", Width 2.4" (16 mm,
61 mm)

LCD Character:

Height .220", Width .145"
(5.6 mm, 3.6 mm)

Operating Temperatures:

32 to 110 degrees Fahrenheit
(0 to 43 degrees Celsius)

Communication Protocol:

Venus 1500

Applications:

DF-2200 series displays

DM-100 Controller Capabilities:

The DM-100 hand-held control device is a multi-purpose controller. It can be used to control several different types of standard displays. This control console contains several basic types of programs. One of these programs must be chosen when the device is initially powered. After a program has been chosen, the device will automatically return to that program every time power is re-connected. A different control program can be chosen any time the unit is powered, but there is a narrow window of time to choose another program during the power up sequenced. The user must determine which program is required to control their particular sign type. Also, within each program, there may be parameters that must be set to make sure the controller matches the actual display.

Time and Temperature mode:

Display digits are fixed XX:XX

User Inputs: Current Time and Date

Options/Settings: 12/24 hour time format, Temperature display format (°C, °F),

Daylight Savings Time (Automatically adjusts on date), Temp Offset.

Petroleum Price Mode:

Display digits are fixed X.XX9/10

User Inputs: Prices for up to 5 products, all products have same digit format above

Option/Settings: Point of Sale (POS) interface, currently we have interfaces for Verifone, Autogas, PAM 1000, Allied, G-Site

Rate Display Mode:

Digits are fixed 2, 4 or 6 digits

User Inputs: Prices for up to 5 lines, must have same digit format on all 5 lines

Options/Settings: Display format options, based on number of digits in display

XX.XX, X.XXX, .XXXX, XXXX.XX, XXX.XX, XX, XXX.X

Lottery Mode:

Displays are fixed 3-digit format X.XX

User Inputs: Amounts for up to 5 lines, each line can have different format

Options/Settings: Display format options, decimal and number of digits shown

Event Counter Mode:

Displays are fixed digit with 2 – 12 digits

User Inputs: Start Time, End Time

Options/Settings: Skip certain days of the week (i.e. weekend days), Expire Event can be set to Do Nothing, Blank Sign, Re-Start, Trigger Relay, Trigger/Blank, Trigger/Re-Start

Event Timer Mode:

Displays are fixed digit with several format options

User Inputs: Start Time, End Time

Options/Settings: Expire Event can be set to Do Nothing, Blank Sign, Re-Start, Trigger Relay, Trigger/Blank, Trigger/Re-Start

Display Format options: DDD HH:MM:SS.s, DDD HH:MM:SS, DDD HH:MM, DDD HH, HH:MM:SS.s, HH:MM:SS, MM:SS.s, MM:SS, SS.s



High-quality, architecturally pleasing, innovative access doors for walls, ceilings, ducts, floors and roofs



FIRE RATED INSULATED - UPSWING DOOR FOR CEILINGS FW-5050-UP

Application

- An insulated, fire rated access door for inward opening in ceilings

Product Features

- For fire rated ceilings, this door has been approved by Warnock Hersey International for 3 hours (max. size to 24" x 36")
- Insulated Door Panel
- Self-Closing
- Self-Latching
- Inside Latch Release

FW-5050-UP Access Door Specifications:

Material: Steel or Stainless Steel

Door: 16 gauge, Flush to frame with reinforced edges filled with 2" thick fire insulation

Mounting Frame: 16 gauge mounting frame, with trim 1" wide

Hinge: Concealed with coil spring for dampening

Fire Rating (Walls): UL — 1-1/2 hour "B" label. ULC — 2 hour "B" label.

Max size: 24 x 36. For Ceilings: Warnock Hersey International 3 hour rated in a non-combustible ceiling. 1 hour rated in a combustibile ceiling. Max size: 24x 36

Standard Latch: L Handle - operable from both sides

Finish: Steel: 5 stage iron phosphate preparation with prime coat of white baked-on enamel.

Stainless Steel: Type 304 - #4 satin polish



STANDARD SIZES (Special sizes available upon request)

NOMINAL DOOR SIZE W X H		WEIGHT PER DOOR		
inches	mm	Latches	lbs.	kg.
22 X 36	560 X 914	2	35	15.9
24 X 24	610 X 610	1	28	12.7
24 X 36	610 X 914	2	38	18.1

Wall or ceiling opening is W + 1/2" (12 mm)
For detailed specifications see submittal sheet

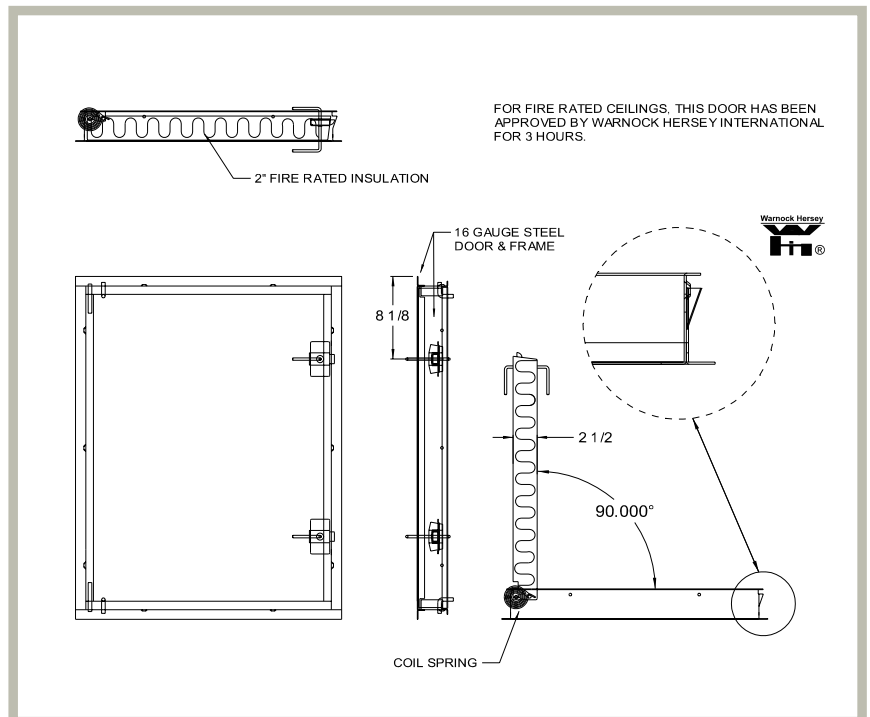

Appendix F

Automated Trailer Mounted Speed Limit Sign

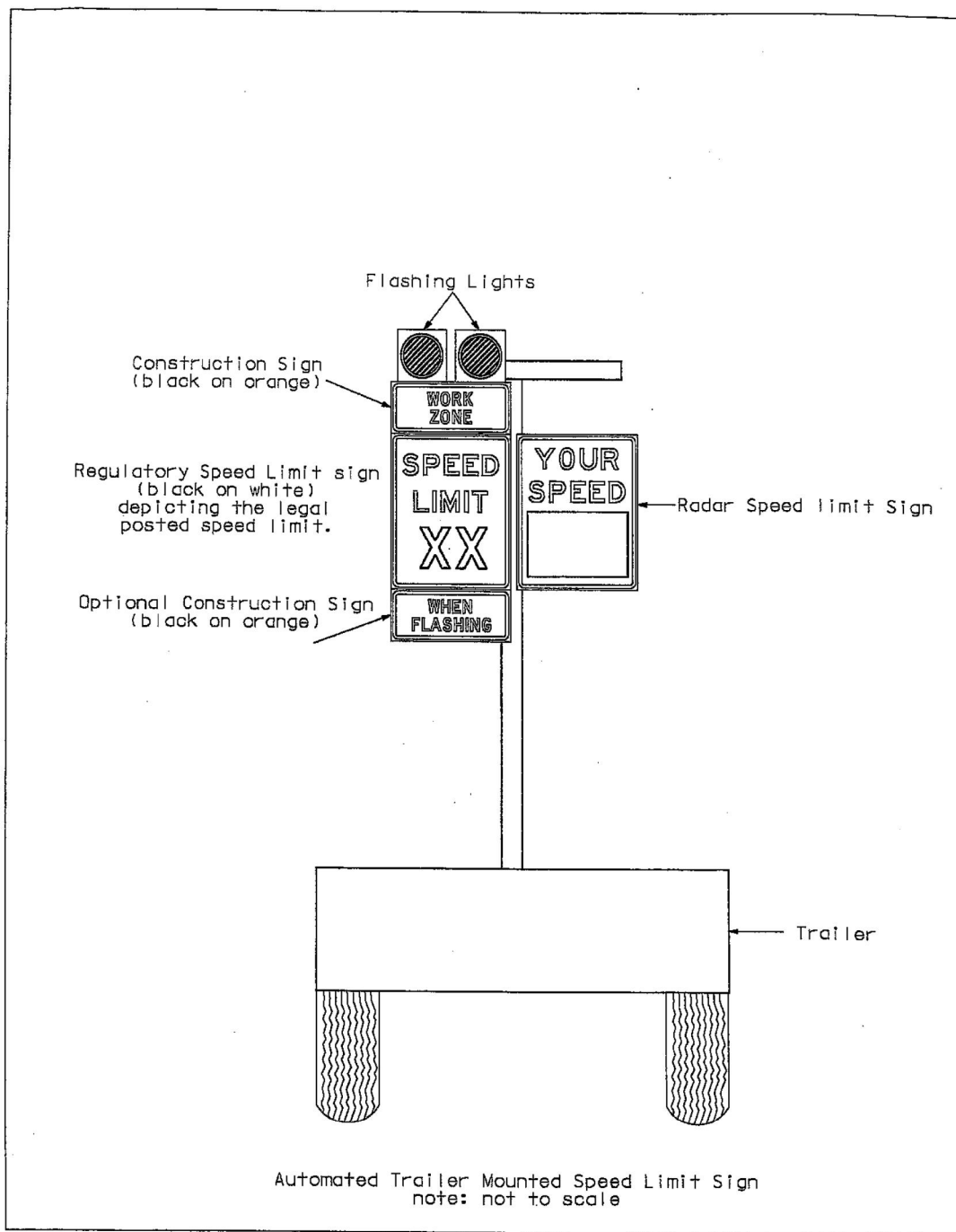

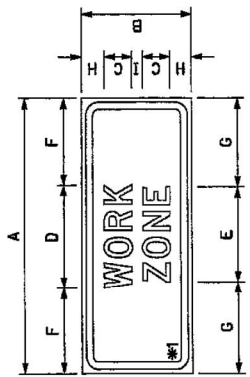

#1

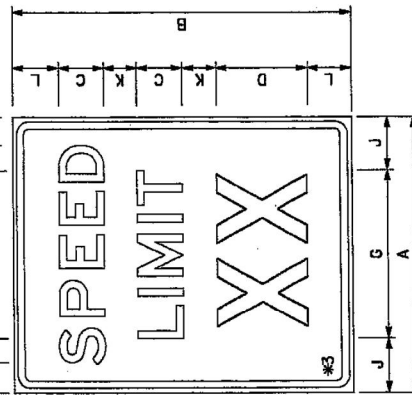

#3

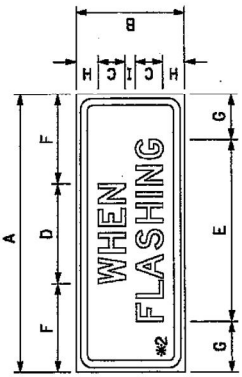

#2

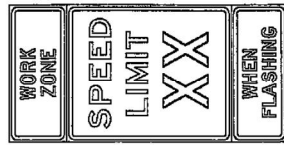

- *1 - 1.25" BORDER, 0.75" INDENT. BLACK ON ORANGE; BB GRADE PLYWOOD SIGN
- *2 - 1.25" BORDER, 0.75" INDENT. BLACK ON WHITE; BB GRADE PLYWOOD SIGN
- *3 - 1.25" BORDER, 0.75" INDENT. BLACK ON WHITE; BB GRADE PLYWOOD SIGN

DIMENSIONS (inches)/LETTER FONTS												
	A	B	C	D	E	F	G	H	I	J	K	L
#1	48	20	5D	18 ¹ / ₈	16 ⁵ / ₈	14 ⁷ / ₈	15 ⁵ / ₈	4	2	N/A	N/A	N/A
#2	48	20	5D	17 ¹ / ₄	31 ³ / ₈	15 ¹ / ₂	8 ¹ / ₄	4	2	N/A	N/A	N/A
#3	48	60	8E	16E	38 ¹ / ₄	29 ¹ / ₄	29 ¹ / ₂	4 ⁷ / ₈	9 ³ / ₈	9 ¹ / ₄	8	6

CONSTRUCTION SIGN/REGULATORY SIGNS

TRAILER MOUNTED CONSTRUCTION ZONE
SPEED LIMIT SIGN

(This page left intentionally blank)

APPENDIX F

SIGN TEXT LAYOUT SHEETS

(This page left intentionally blank)

SIGN DETAIL
N.T.S.



6.0" RADIUS, 2.0" BORDER, WHITE ON GREEN;
[EXIT 7] E 2K;
12.0" RADIUS, 2.0" BORDER, WHITE ON GREEN;
[TO] E 2K; STATE HIGHWAY 91 M1-5;
[YORK] E MOD 2K; [KITTERY] E MOD 2K; [1 MILE] E 2K;
NOTE: DIAGRAM DIMENSIONS ARE IN INCHES



**Maine
Turnpike
Authority**

SIGN NUMBER	D-3
WIDTH x HGHT.	13'-0" X 12'-0"
BORDER WIDTH	2
CORNER RADIUS	12
MOUNTING	Ground
BACKGROUND	TYPE: Reflective
	COLOR: Green
LEGEND/BORDER	TYPE: Reflective
	94.0 White

SYMBOL	X	Y	WID	HT
M1-4(1)	51.4	94.0	36.0	36
M-5(91)	101.9	94.0	36.0	36

LETTER POSITIONS (X)

LENGTH SERIES/SIZE

Letter	X	Y	WID	HT	Series/Size			
E	25.6	34.5	45.3	48.8	59.0	76.3	59.7	10 / 15
T	18.6	29.3					10.7	12
Y	49.5	68.1	83.9	95.8			62.3	EMOD 16
K	34.3	50.9	58.8	70.5	82.5	98.0	108.0	EMOD 16
1	51.6	56.1	71.1	83.1	87.5	96.8	57.2	E 15 / 10

SIGN DETAIL
N.T.S.



6.0" RADIUS, 2.0" BORDER, WHITE ON GREEN;
[EXIT 7] E 2K;
12.0" RADIUS, 2.0" BORDER, WHITE ON GREEN;
[TO] E 2K; STATE HIGHWAY 91 M1-5;
[YORK] E MOD 2K; [KITTERY] E MOD 2K;
[3 MILES] E 2K;

NOTE: DIAGRAM DIMENSIONS ARE IN INCHES



Maine Turnpike Authority

SIGN NUMBER	D-4
WIDTH x HGHT.	13'-0" X 12'-0"
BORDER WIDTH	2
CORNER RADIUS	12
MOUNTING	Ground
BACKGROUND	TYPE: Reflective
	COLOR: Green
LEGEND/BORDER	TYPE: Reflective
	COLOR: White

SYMBOL	X	Y	WID	HT
M1-4(1)	51.4	94.0	36.0	36
M-5(91)	101.9	94.0	36.0	36

LETTER POSITIONS (X)

LENGTH SERIES/SIZE

E	X	I	T		7																			
25.6	34.5	45.3	48.8	59.0	76.3														59.7	E	10 / 15			
T	O																					E	12	
18.6	29.3																							
Y	o	r	k																				EMOD	16
49.5	68.1	83.9	95.8																					
K	i	t	t	e	r	y																	EMOD	16
34.3	50.9	58.8	70.5	82.5	98.0	108.0																		
3		M	I	L	E	S																	E	15 / 10
43.0	55.1	70.1	82.2	86.7	95.3	104.9																		

SIGN DETAIL
N.T.S.



Maine Turnpike Authority

SIGN NUMBER	R3-16A
WIDTH x HGHT.	19'-0" x 7'-0"
BORDER WIDTH	2
CORNER RADIUS	12
MOUNTING	Overhead
BACKGROUND	TYPE: Reflective
	COLOR: Purple / Green
LEGEND/BORDER	TYPE: Reflective
	COLOR: White

SYMBOL	X	Y	WID	HT
DOWN ARROW	17.3	7.5	32	22
DOWN ARROW	178.7	7.5	32	22
E-ZPass Panel	59.0	60.0	84	24
ONLY Panel	141.0	62.0	57	20

12.0" RADIUS, 2.0" BORDER, WHITE ON PURPLE;
RECTANGLE WHITE;
12.0" RADIUS, 2.0" BORDER, WHITE ON GREEN;
[NO CASH] E 2K; DOWN ARROW 22.0" 270°; DOWN ARROW 22.0" 270°;
NOTE: DIAGRAM DIMENSIONS ARE IN INCHES

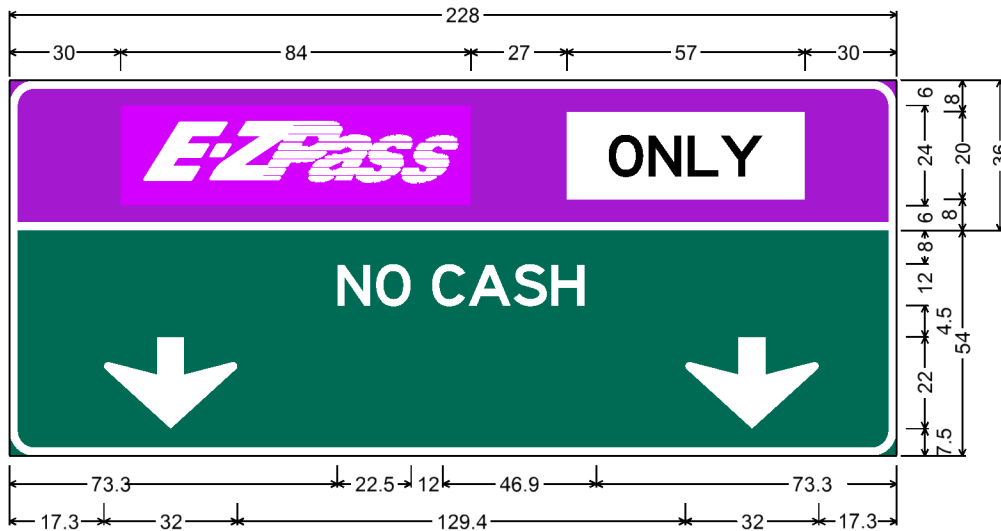

LETTER POSITIONS (X)

LENGTH SERIES/SIZE

N	O		C	A	S	H												E		
73.3	85.8	97.8	107.9	119.3	132.9	145.0												83.7	12	

SIGN DETAIL
N.T.S.



Maine Turnpike Authority

SIGN NUMBER	R3-16B
WIDTH x HGHT.	30'-0" x 7'-6"
BORDER WIDTH	2
CORNER RADIUS	12
MOUNTING	Overhead
BACKGROUND	TYPE: Reflective
	COLOR: Purple / Green
LEGEND/BORDER	TYPE: Reflective
	COLOR: White

SYMBOL	X	Y	WID	HT
DOWN ARROW	20.0	7.0	32	22
DOWN ARROW	164.0	7.0	32	22
DOWN ARROW	308.0	7.0	32	22
E-ZPass Panel	91.0	60.0	84	24
ONLY Panel	209.0	62.0	60	20

12.0" RADIUS, 2.0" BORDER, WHITE ON PURPLE;
RECTANGLE WHITE;
12.0" RADIUS, 2.0" BORDER, WHITE ON GREEN;
[NO CASH] E 2K; DOWN ARROW 22.0" 270°; DOWN ARROW 22.0" 270°; DOWN ARROW 22.0" 270°;

NOTE: DIAGRAM DIMENSIONS ARE IN INCHES

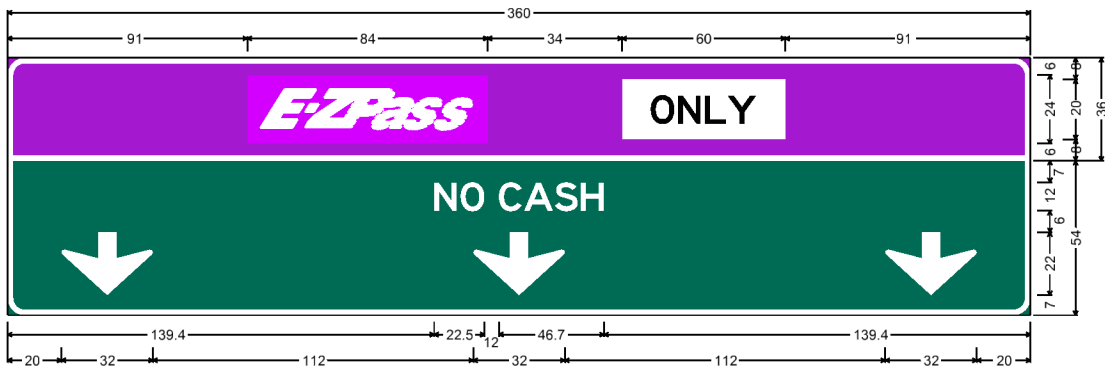

LETTER POSITIONS (X)

LENGTH

SERIES/SIZE

N	O		C	A	S	H												E		
139.4	151.8	163.8	173.9	185.3	198.9	211.0												83.4	12	

SIGN DETAIL
N.T.S.



12.0" RADIUS, 2.0" BORDER, BLACK ON YELLOW;
 [PAY TOLL] E MOD 2K;
 [1 MILE] E MOD 2K;
 12.0" RADIUS, 2.0" BORDER, WHITE ON GREEN;
 [CASH] E MOD 2K;
 [CARS \$3.00] E MOD 2K 50% SPACING;
 DOWN ARROW 22.0" 270°;

NOTE: DIAGRAM DIMENSIONS ARE IN INCHES



Maine Turnpike Authority

SIGN NUMBER	SP-1
WIDTH x HGHT.	9' - 0" x 10' - 6"
BORDER WIDTH	2"
CORNER RADIUS	12"
MOUNTING	Overhead
BACKGROUND	TYPE: Reflective
	COLOR: Yellow / Green
LEGEND/BORDER	TYPE: Reflective
	COLOR: Black / White

SYMBOL	X	Y	WID	HT
DOWN ARROW	38.0	7.0	32	22

LETTER POSITIONS (X)

LENGTH SERIES/SIZE

P	A	Y		T	O	L	L									EMOD	
16.0	24.9	35.8	44.8	55.9	64.7	75.5	84.5									77.5	10
1		M	I	L	E												EMOD
30.8	39.8	43.8	55.9	60.7	69.7											47.9	10
C	A	S	H														EMOD
34.2	43.5	55.1	65.7													40.5	10
C	A	R	S		\$	3	.	0	0								EMOD
11.5	20.2	31.2	40.2	49.2	58.3	67.2	76.0	78.7	88.1							85.6	10

SIGN DETAIL
N.T.S.

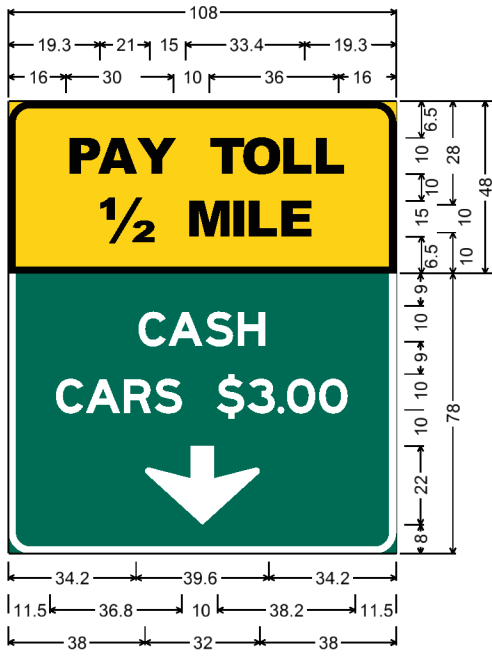

12.0" RADIUS, 2.0" BORDER, BLACK ON YELLOW;
[PAY TOLL] E MOD 2K;
[1/2] E MOD 2K [MILE] E 2K;
12.0" RADIUS, 2.0" BORDER, WHITE ON GREEN;
[CASH] E MOD 2K;
[CARS \$3.00] E MOD 2K 50% SPACING;
DOWN ARROW 22.0" 270°;

NOTE: DIAGRAM DIMENSIONS ARE IN INCHES



Maine Turnpike Authority

SIGN NUMBER	SP-2
WIDTH x HGHT.	9'-0" x 10'-6"
BORDER WIDTH	2
CORNER RADIUS	12
MOUNTING	Overhead
BACKGROUND	TYPE: Reflective
	COLOR: Yellow / Green
LEGEND/BORDER	TYPE: Reflective
	COLOR: Black / White

SYMBOL	X	Y	WID	HT
DOWN ARROW	38.0	8.0	32	22

LETTER POSITIONS (X)

LENGTH SERIES/SIZE

P	A	Y		T	O	L	L													EMOD
16.0	24.9	35.8	44.8	55.9	64.7	75.5	84.5													77.5 10
1/2		M	I	L	E															EMOD 15 /10
19.3	28.3	55.3	67.4	72.2	81.2															70.9
C	A	S	H																	EMOD 10
34.2	43.5	55.1	65.7																	40.5
C	A	R	S		\$	3	.	0	0											EMOD 10
11.5	20.2	31.2	40.2	49.2	58.3	67.2	76.0	78.7	88.1											85.6

SIGN DETAIL
N.T.S.

SP-12

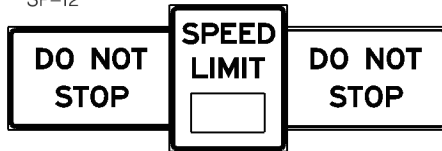

Maine Turnpike Authority

SIGN NUMBER SP-12

WIDTH x HGHT.	5'-6" x 3'-6"
BORDER WIDTH	1.25
CORNER RADIUS	3
MOUNTING	Overhead
BACKGROUND	TYPE: Reflective
	COLOR: White
LEGEND/BORDER	TYPE: Reflective
	COLOR: Black

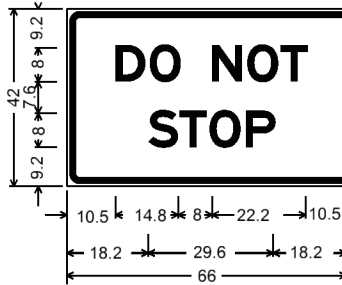

3.0" RADIUS, 1.3" BORDER, 0.8" INDENT, BLACK ON WHITE; [DO NOT] E 2K; [STOP] E 2K;

NOTE: DIAGRAM DIMENSIONS ARE IN INCHES

LETTER POSITIONS (X)

											LENGTH	SERIES/SIZE
D	O		N	O	T						47.0	E 8
10.5	18.6	26.6	33.3	41.6	49.5							
S	T	O	P								31.1	E 8
18.2	25.6	32.7	41.3									

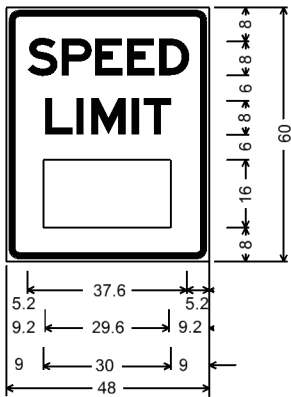

SYMBOL	X	Y	WID	HT
(DIGITAL DISPLAY)	9.0	8.0	30	16

3.0" RADIUS, 1.3" BORDER, 0.8" INDENT, BLACK ON WHITE; [SPEED] E 2K; [LIMIT] E 2K; [00] E 2K;

NOTE: DIAGRAM DIMENSIONS ARE IN INCHES

WIDTH x HGHT.	4'-0" x 5'-0"
BORDER WIDTH	1.25
CORNER RADIUS	3
MOUNTING	Overhead
BACKGROUND	TYPE: Reflective
	COLOR: White
LEGEND/BORDER	TYPE: Reflective
	COLOR: Black

LETTER POSITIONS (X)

											LENGTH	SERIES/SIZE
S	P	E	E	D							39.1	E 8
5.2	13.3	21.1	28.7	36.3								
L	I	M	I	T							31.2	E 8
9.4	16.7	20.2	29.8	32.6								

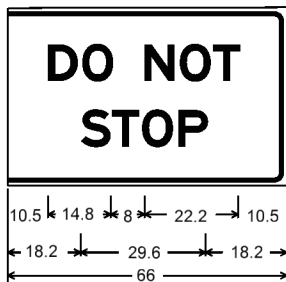

3.0" RADIUS, 1.3" BORDER, 0.8" INDENT, BLACK ON WHITE; [DO NOT] E 2K; [STOP] E 2K;

NOTE: DIAGRAM DIMENSIONS ARE IN INCHES

WIDTH x HGHT.	5'-6" x 3'-6"
BORDER WIDTH	1.25
CORNER RADIUS	3
MOUNTING	Overhead
BACKGROUND	TYPE: Reflective
	COLOR: White
LEGEND/BORDER	TYPE: Reflective
	COLOR: Black

LETTER POSITIONS (X)

											LENGTH	SERIES/SIZE
D	O		N	O	T						47.0	E 8
10.5	18.6	26.6	33.3	41.6	49.5							
S	T	O	P								31.0	E 8
18.2	25.6	32.7	41.3									

SIGN DETAIL
N.T.S.



12.0" RADIUS, 2.0" BORDER, BLACK ON YELLOW;
 [PAY TOLL] E MOD 2K;
 [1 MILE] E MOD 2K;
 12.0" RADIUS, 2.0" BORDER, WHITE ON GREEN;
 [CASH] E MOD 2K;
 [CARS \$3.00] E MOD 2K 50% SPACING;
 DOWN ARROW 22.0" 270°;

NOTE: DIAGRAM DIMENSIONS ARE IN INCHES



Maine Turnpike Authority

SIGN NUMBER	SP-1
WIDTH x HGHT.	9' - 0" x 10' - 6"
BORDER WIDTH	2"
CORNER RADIUS	12"
MOUNTING	Overhead
BACKGROUND	TYPE: Reflective
	COLOR: Yellow / Green
LEGEND/BORDER	TYPE: Reflective
	COLOR: Black / White

SYMBOL	X	Y	WID	HT
DOWN ARROW	38.0	7.0	32	22

LETTER POSITIONS (X)

LENGTH SERIES/SIZE

P	A	Y		T	O	L	L									EMOD	
16.0	24.9	35.8	44.8	55.9	64.7	75.5	84.5									77.5	10
1		M	I	L	E												EMOD
30.8	39.8	43.8	55.9	60.7	69.7											47.9	10
C	A	S	H														EMOD
34.2	43.5	55.1	65.7													40.5	10
C	A	R	S		\$	3	.	0	0								EMOD
11.5	20.2	31.2	40.2	49.2	58.3	67.2	76.0	78.7	88.1							85.6	10

SIGN DETAIL
N.T.S.



Maine Turnpike Authority

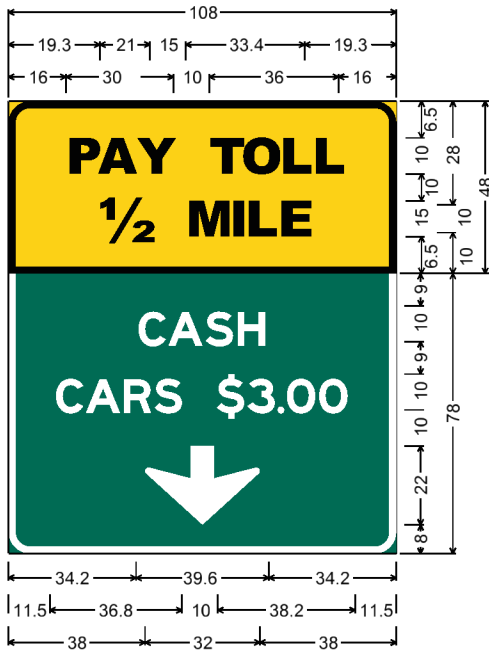

12.0" RADIUS, 2.0" BORDER, BLACK ON YELLOW;
 [PAY TOLL] E MOD 2K;
 [1/2] E MOD 2K [MILE] E 2K;
 12.0" RADIUS, 2.0" BORDER, WHITE ON GREEN;
 [CASH] E MOD 2K;
 [CARS \$3.00] E MOD 2K 50% SPACING;
 DOWN ARROW 22.0" 270°;

NOTE: DIAGRAM DIMENSIONS ARE IN INCHES

SIGN NUMBER	SP-2
WIDTH x HGHT.	9'-0" x 10'-6"
BORDER WIDTH	2
CORNER RADIUS	12
MOUNTING	Overhead
BACKGROUND	TYPE: Reflective
	COLOR: Yellow / Green
LEGEND/BORDER	TYPE: Reflective
	COLOR: Black / White

SYMBOL	X	Y	WID	HT
DOWN ARROW	38.0	8.0	32	22

LETTER POSITIONS (X)

LENGTH SERIES/SIZE

P	A	Y		T	O	L	L												EMOD	
16.0	24.9	35.8	44.8	55.9	64.7	75.5	84.5												77.5	10
1/2		M	I	L	E															EMOD
19.3	28.3	55.3	67.4	72.2	81.2														70.9	15 /10
C	A	S	H																	EMOD
34.2	43.5	55.1	65.7																40.5	10
C	A	R	S		\$	3	.	0	0											EMOD
11.5	20.2	31.2	40.2	49.2	58.3	67.2	76.0	78.7	88.1										85.6	10

SIGN DETAIL
N.T.S.



**Maine
Turnpike
Authority**

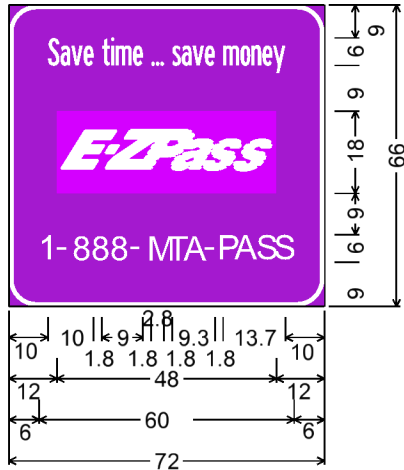

9.0" RADIUS, 1.25" BORDER, WHITE ON PURPLE;
[SAVE TIME ... SAVE MONEY] B 2K 30% SPACING;
[1-888-MTA-PASS] D 2K;

NOTE: DIAGRAM DIMENSIONS ARE IN INCHES

SIGN NUMBER	SP-3
WIDTH x HGHT.	6'-0" x 5'-6"
BORDER WIDTH	1.25
CORNER RADIUS	9
MOUNTING	Ground
BACKGROUND	TYPE: Reflective
	COLOR: Purple
LEGEND/BORDER	TYPE: Reflective
	COLOR: White

SYMBOL	X	Y	WID	HT
E-ZPass Panel	12.0	24.0	48	18

LETTER POSITIONS (X)

LENGTH SERIES/SIZE

S	a	v	e	t	i	m	e	.	.	.							
10.0	12.7	15.1	17.8	20.8	21.8	23.8	24.8	28.6	32.6	33.6	34.6						
			s	a	v	e	m	o	n	e	y						D
			37.2	39.2	41.6	44.3	47.3	48.3	52.1	54.6	56.9	59.2				52.2	6
1		-	8	8	8		-		M	T	A						
6.7	7.5	8.9	10.0	11.6	16.7	21.7	24.4	26.4	25.4	29.2	34.6	38.6	41.5				
		P	A	S	S												
44.0	45.0	46.8	51.2	56.7	61.2											57.5	6

SIGN DETAIL
N.T.S.



**Maine
Turnpike
Authority**

SIGN NUMBER	SP-4
WIDTH x HGHT.	18'-6" x 10'-6"
BORDER WIDTH	2
CORNER RADIUS	9
MOUNTING	Overhead
BACKGROUND	TYPE: Reflective
	COLOR: Yellow / Green
LEGEND/BORDER	TYPE: Reflective
	COLOR: Black / White

9.0" RADIUS, 2.0" BORDER, BLACK ON YELLOW;
 [STOP AHEAD] E MOD 2K; [PAY TOLL] E MOD 2K;
 9.0" RADIUS, 2.0" BORDER, WHITE ON GREEN;
 [CASH] E MOD 2K; [CARS \$3.00] E MOD 2K; DOWN ARROW 22.0" 270°;
 DOWN ARROW 22.0" 270°;

NOTE: DIAGRAM DIMENSIONS ARE IN INCHES

SYMBOL	X	Y	WID	HT
DOWN ARROW	23.0	9.0	32	22
DOWN ARROW	167.0	9.0	32	22

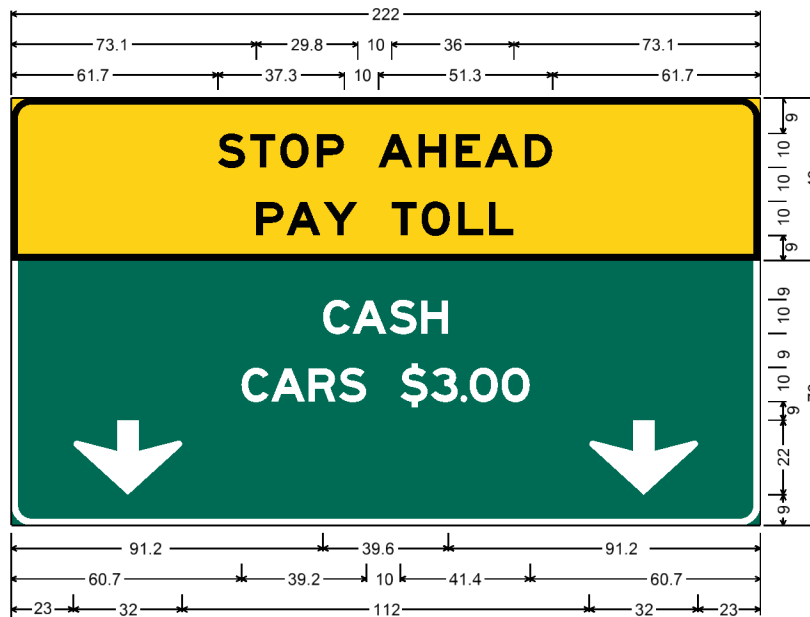

LETTER POSITIONS (X)

LENGTH SERIES/SIZE

S	T	O	P		A	H	E	A	D														
61.7	71.3	80.1	90.9	100.9	109.0	120.9	131.5	140.3	152.2											100.5	E	10	
73.1	82.0	92.9	102.9	112.9	121.8	132.6	141.6																
91.2	100.5	112.1	122.7																				
60.7	70.0	81.9	91.8	101.8	119.9	129.6	139.1	142.5	152.9														

SIGN DETAIL
N.T.S.



Maine Turnpike Authority

SIGN NUMBER	SP-5A
WIDTH x HGHT.	25'-0" x 11'-0"
BORDER WIDTH	2
CORNER RADIUS	12
MOUNTING	Overhead
BACKGROUND	TYPE: Reflective
	COLOR: Yellow / Green
LEGEND/BORDER	TYPE: Reflective
	COLOR: Black / White

12.0" RADIUS, 2.0" BORDER, BLACK ON YELLOW;
[PAY TOLL 1/4] E MOD 2K (MILE) E 2K;
12.0" RADIUS, 2.0" BORDER, WHITE ON GREEN;
RECTANGLE PURPLE; RECTANGLE WHITE;
[NO CASH] E MOD 2K; [CASH] E 2K;

NOTE: DIAGRAM DIMENSIONS ARE IN INCHES

SYMBOL	X	Y	WID	HT
E-ZPass Panel	20.0	83.7	84	24
ONLY Panel	39.5	50.7	57	25
Arrow Diagramatic	118.0	13.0	88	110

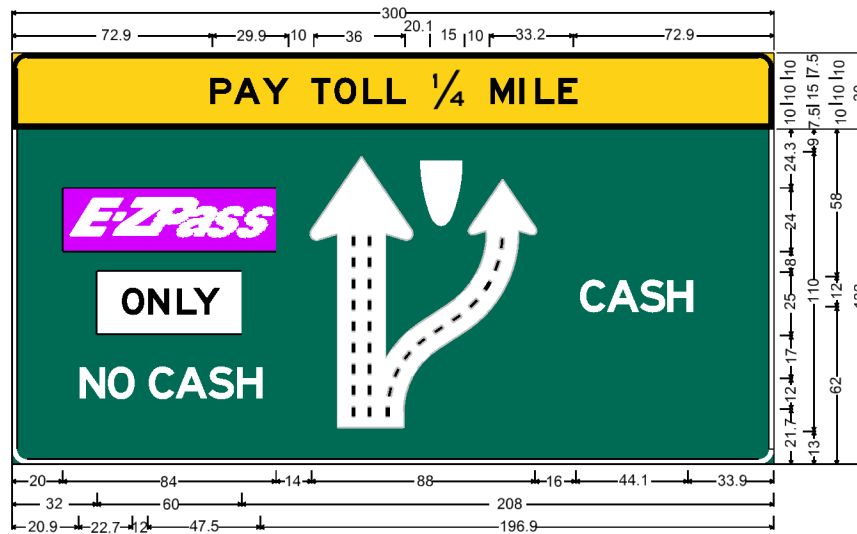

LETTER POSITIONS (X)

LENGTH SERIES/SIZE

P	A	Y		T	O	L	L		1/4		M	I	L	E		EMOD
72.9	81.8	92.7	101.7	112.8	121.6	132.4	141.4	150.4	158.8	167.8	193.9	205.9	210.7	219.7	155.8	10 /15 /10
C	A	S	H													EMOD
222.0	233.4	247.0	259.1												46.1	12
N	O		C	A	S	H										E
20.9	33.5	42.5	55.6	66.7	80.7	93.4									81.5	12

SIGN DETAIL
N.T.S.



Maine Turnpike Authority

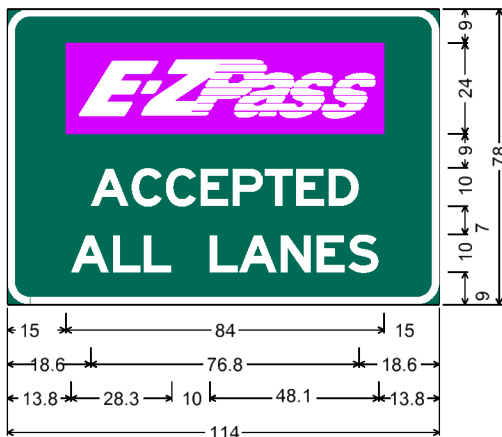

9.0" RADIUS, 2.0" BORDER, WHITE ON GREEN;
[ACCEPTED] E MOD 2K;
[ALL LANES] E MOD 2K;

NOTE: DIAGRAM DIMENSIONS ARE IN INCHES

SIGN NUMBER	SP-6
WIDTH x HGHT.	9'-6" x 6'-6"
BORDER WIDTH	2
CORNER RADIUS	9
MOUNTING	Ground
BACKGROUND	TYPE: Reflective
	COLOR: Green
LEGEND/BORDER	TYPE: Reflective
	COLOR: White

SYMBOL	X	Y	WID	HT
E-ZPass Panel	15.4	45.0	84	24

LETTER POSITIONS (X)

LENGTH SERIES/SIZE

A	C	C	E	P	T	E	D										EMOD
18.6	30.1	40.0	50.3	59.8	68.7	77.8	87.3										10
A	L	L		L	A	N	E	S									EMOD
13.8	25.7	34.7	44.0	52.1	60.1	72.0	82.9	92.1									10

SIGN DETAIL
N.T.S.



**Maine
Turnpike
Authority**

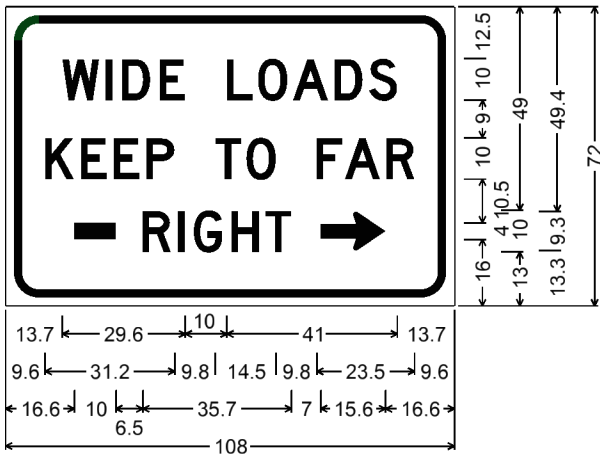

9.0" RADIUS, 2.0" BORDER, 2.0" INDENT, BLACK ON WHITE;
 [WIDE LOADS] D 2K;
 [KEEP TO FAR] D 2K;
 [RIGHT] D 2K;
 STANDARD ARROW CUSTOM 15.6" X 9.4" 0°;

NOTE: DIAGRAM DIMENSIONS ARE IN INCHES

SIGN NUMBER	SP-7
WIDTH x HGHT.	9'-0" x 6'-0"
BORDER WIDTH	2
CORNER RADIUS	9
MOUNTING	Ground
BACKGROUND	TYPE: Reflective
	COLOR: White
LEGEND/BORDER	TYPE: Reflective
	COLOR: Black

SYMBOL	X	Y	WID	HT
Arrow Segment	16.5	16.0	10	4
Arrow Right	75.8	13.0	23.5	10

LETTER POSITIONS (X)

LENGTH SERIES/SIZE

W	I	D	E		L	O	A	D	S									D	
13.6	24.1	28.1	37.1	43.2	53.3	60.8	69.1	79.1	87.5									80.7	10
K	E	E	P		T	O		F	A	R									D
9.5	18.1	26.0	33.9	40.7	50.5	58.0	74.1	74.9	81.6	91.6								88.9	10
R	I	G	H	T															D
33.0	41.5	45.3	54.3	62.6														35.8	10

SIGN DETAIL
N.T.S.



**Maine
Turnpike
Authority**

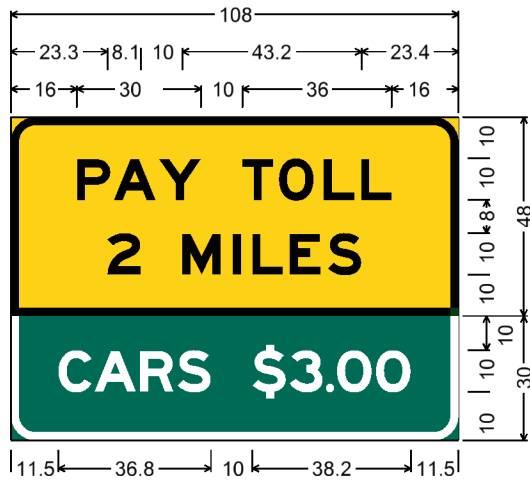

9.0" RADIUS, 2.0" BORDER, BLACK ON YELLOW;
[PAY TOLL] E MOD 2K;
[2 MILES] E MOD 2K;
9.0" RADIUS, 2.0" BORDER, WHITE ON GREEN;
[CARS \$3.00] E MOD 2K; 50% SPACING.

NOTE: DIAGRAM DIMENSIONS ARE IN INCHES

SIGN NUMBER	SP-8
WIDTH x HGHT.	9'-0" x 7'-6"
BORDER WIDTH	2
CORNER RADIUS	9
MOUNTING	Ground
BACKGROUND	TYPE: Reflective
	COLOR: Yellow / Green
LEGEND/BORDER	TYPE: Reflective
	COLOR: Black / White

SYMBOL	X	Y	WID	HT

LETTER POSITIONS (X)

LENGTH SERIES/SIZE

P	A	Y		T	O	L	L														EMOD			
16.0	24.9	35.8	45.9	55.9	64.7	75.5	84.5														75.9	10		
2		M	I	L	E	S																	EMOD	
23.3	31.4	41.4	53.5	58.3	67.3	76.5																61.3	10	
C	A	R	S		\$	3	.	0	0														EMOD	
11.5	20.2	31.2	40.2	48.3	58.3	67.2	76.0	78.7	88.1														85.0	10

SIGN DETAIL
N.T.S.



**Maine
Turnpike
Authority**

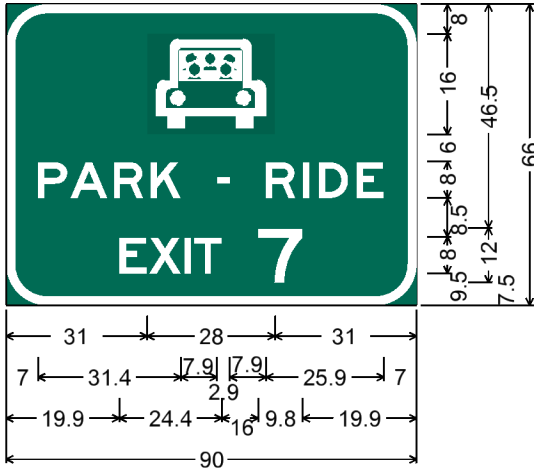

9.0" RADIUS, 2.0" BORDER, WHITE ON GREEN;
[PARK - RIDE] E 2K;
[EXIT 7] E 2K;

NOTE: DIAGRAM DIMENSIONS ARE IN INCHES

SIGN NUMBER	SP-9
WIDTH x HGHT.	7'-6" x 5'-6"
BORDER WIDTH	2
CORNER RADIUS	9
MOUNTING	Ground
BACKGROUND	TYPE: Reflective
	COLOR: Green
LEGEND/BORDER	TYPE: Reflective
	COLOR: White

SYMBOL	X	Y	WID	HT
"Park and Ride" Car	31.0	40.0	28	16

LETTER POSITIONS (X)

LENGTH SERIES/SIZE

P	A	R	K		-		R	I	D	E							E
7.0	14.1	23.6	31.6	38.4	46.3	49.1	57.0	65.0	68.5	76.9						75.9	8
E	X	I	T		7												E
19.9	26.9	35.5	38.3	47.3	60.3											47.4	8 / 12

SIGN DETAIL
N.T.S.



**Maine
Turnpike
Authority**

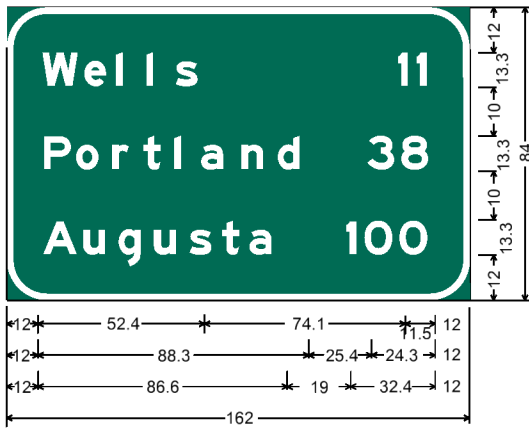

12.0" RADIUS, 2.0" BORDER, WHITE ON GREEN;
 [WELLS] E MOD 2K; [11 MI] E MOD 2K;
 [PORTLAND] E MOD 2K; [36 MI] E MOD 2K;
 [AUGUSTA] E MOD 2K; [100 MI] E MOD 2K;

NOTE: DIAGRAM DIMENSIONS ARE IN INCHES

SIGN NUMBER	SP-10
WIDTH x HGHT.	13'- 6" x 7'- 0"
BORDER WIDTH	2
CORNER RADIUS	12
MOUNTING	Ground
BACKGROUND	TYPE: Reflective
	COLOR: Green
LEGEND/BORDER	TYPE: Reflective
	COLOR: White

SYMBOL	X	Y	WID	HT

LETTER POSITIONS (X)

LENGTH SERIES/SIZE

W	e	l	l	s		1	1									EMOD
12.0	28.1	41.1	49.1	55.6	63.6	140.1	147.5								143.5	13.33 /10
P	o	r	t	l	a	n	d		3	8						EMOD
12.0	24.8	38.1	46.4	57.6	64.4	72.4	91.5	99.5	127.3	140.8					136.8	13.33 /10
A	u	g	u	s	t	a		1	0	0						EMOD
12.0	28.6	41.6	55.8	68.4	79.9	89.9	97.9	119.3	126.5	140.4					136.4	13.33 /10

SIGN DETAIL
N.T.S.



**Maine
Turnpike
Authority**

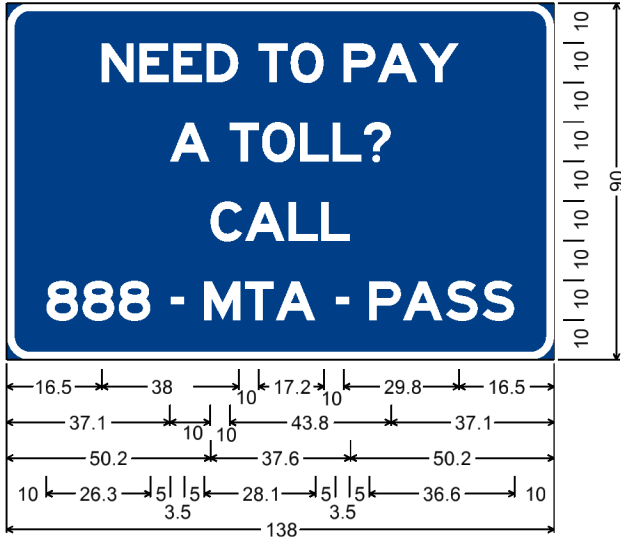

12.0" RADIUS, 2.0" BORDER, WHITE ON BLUE;
 [NEED TO PAY] E MOD 2K;
 [A TOLL?] E MOD 2K;
 [CALL] E MOD 2K;
 [888 - MTA - PASS] E MOD 2K 50% SPACING;
 NOTE: DIAGRAM DIMENSIONS ARE IN INCHES

SIGN NUMBER	SP-11
WIDTH x HGHT.	11'-6" x 7'-6"
BORDER WIDTH	2
CORNER RADIUS	12
MOUNTING	Ground
BACKGROUND	TYPE: Reflective
	COLOR: Blue
LEGEND/BORDER	TYPE: Reflective
	COLOR: White

SYMBOL	X	Y	WID	HT

LETTER POSITIONS (X)

LENGTH SERIES/SIZE

N	E	E	D		T	O		P	A	Y											
16.5	27.4	36.9	46.4	56.0	64.5	73.3	82.0	91.7	100.61	56.0										EMOD	
																					10
A		T	O	L	L	?															EMOD
37.1	46.1	57.2	66.0	76.8	85.9	94.1															10
C	A	L	L																		EMOD
50.2	59.5	71.4	80.4																		10
8	8	8		-		M	T	A		-											
10.0	19.1	28.2	36.3	41.3	44.8	49.8	60.0	67.8	77.9	82.9											
			P	A	S	S															EMOD
			86.4	91.4	99.9	110.8	120.0														10

SIGN DETAIL
N.T.S.



12.0" RADIUS, 2.0" BORDER, BLACK ON YELLOW;
 [PAY TOLL] E MOD 2K;
 [1 MILE] E MOD 2K;
 12.0" RADIUS, 2.0" BORDER, WHITE ON GREEN;
 [CASH] E MOD 2K;
 [CARS \$3.00] E MOD 2K 50% SPACING;
 DOWN ARROW 22.0" 270°;

NOTE: DIAGRAM DIMENSIONS ARE IN INCHES



Maine Turnpike Authority

SIGN NUMBER	SP-1
WIDTH x HGHT.	9' - 0" x 10' - 6"
BORDER WIDTH	2"
CORNER RADIUS	12"
MOUNTING	Overhead
BACKGROUND	TYPE: Reflective
	COLOR: Yellow / Green
LEGEND/BORDER	TYPE: Reflective
	COLOR: Black / White

SYMBOL	X	Y	WID	HT
DOWN ARROW	38.0	7.0	32	22

LETTER POSITIONS (X)

LENGTH SERIES/SIZE

P	A	Y		T	O	L	L									EMOD	
16.0	24.9	35.8	44.8	55.9	64.7	75.5	84.5									77.5	10
1		M	I	L	E												EMOD
30.8	39.8	43.8	55.9	60.7	69.7											47.9	10
C	A	S	H														EMOD
34.2	43.5	55.1	65.7													40.5	10
C	A	R	S		\$	3	.	0	0								EMOD
11.5	20.2	31.2	40.2	49.2	58.3	67.2	76.0	78.7	88.1							85.6	10

SIGN DETAIL
N.T.S.

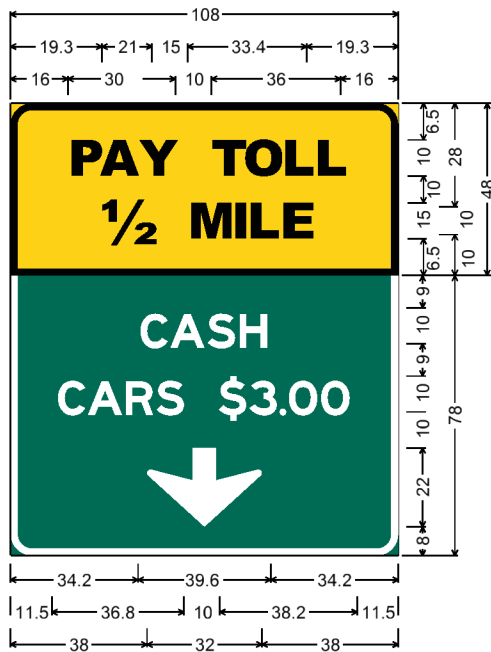

12.0" RADIUS, 2.0" BORDER, BLACK ON YELLOW;
[PAY TOLL] E MOD 2K;
[1/2] E MOD 2K [MILE] E 2K;
12.0" RADIUS, 2.0" BORDER, WHITE ON GREEN;
[CASH] E MOD 2K;
[CARS \$3.00] E MOD 2K 50% SPACING;
DOWN ARROW 22.0" 270°;

NOTE: DIAGRAM DIMENSIONS ARE IN INCHES



Maine Turnpike Authority

SIGN NUMBER	SP-2
WIDTH x HGHT.	9'-0" x 10'-6"
BORDER WIDTH	2
CORNER RADIUS	12
MOUNTING	Overhead
BACKGROUND	TYPE: Reflective
	COLOR: Yellow / Green
LEGEND/BORDER	TYPE: Reflective
	COLOR: Black / White

SYMBOL	X	Y	WID	HT
DOWN ARROW	38.0	8.0	32	22

LETTER POSITIONS (X)

LENGTH SERIES/SIZE

P	A	Y			T	O	L	L							EMOD
16.0	24.9	35.8	44.8	55.9	64.7	75.5	84.5								10
1/2		M	I	L	E										EMOD
19.3	28.3	55.3	67.4	72.2	81.2										15 /10
C	A	S	H												EMOD
34.2	43.5	55.1	65.7												10
C	A	R	S		\$	3	.	0	0						EMOD
11.5	20.2	31.2	40.2	49.2	58.3	67.2	76.0	78.7	88.1						10

SIGN DETAIL
N.T.S.

SP-12

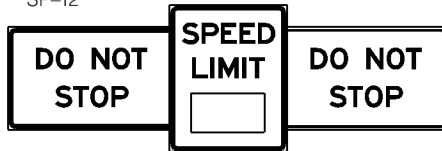

Maine Turnpike Authority

SIGN NUMBER SP-12

WIDTH x HGHT.	5'-6" x 3'-6"
BORDER WIDTH	1.25
CORNER RADIUS	3
MOUNTING	Overhead
BACKGROUND	TYPE: Reflective
	COLOR: White
LEGEND/BORDER	TYPE: Reflective
	COLOR: Black

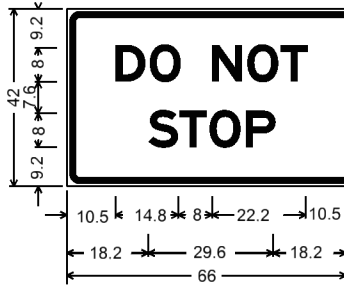

3.0" RADIUS, 1.3" BORDER, 0.8" INDENT, BLACK ON WHITE; [DO NOT] E 2K; [STOP] E 2K;

NOTE: DIAGRAM DIMENSIONS ARE IN INCHES

LETTER POSITIONS (X)

LETTER POSITIONS (X)											LENGTH	SERIES/SIZE
D	O		N	O	T						47.0	E 8
10.5	18.6	26.6	33.3	41.6	49.5							
S	T	O	P								31.1	E 8
18.2	25.6	32.7	41.3									

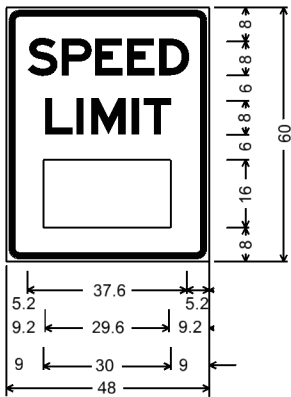

SYMBOL	X	Y	WID	HT
(DIGITAL DISPLAY)	9.0	8.0	30	16

3.0" RADIUS, 1.3" BORDER, 0.8" INDENT, BLACK ON WHITE; [SPEED] E 2K; [LIMIT] E 2K; [00] E 2K;

NOTE: DIAGRAM DIMENSIONS ARE IN INCHES

WIDTH x HGHT.	4'-0" x 5'-0"
BORDER WIDTH	1.25
CORNER RADIUS	3
MOUNTING	Overhead
BACKGROUND	TYPE: Reflective
	COLOR: White
LEGEND/BORDER	TYPE: Reflective
	COLOR: Black

LETTER POSITIONS (X)

LETTER POSITIONS (X)											LENGTH	SERIES/SIZE
S	P	E	E	D							39.1	E 8
5.2	13.3	21.1	28.7	36.3								
L	I	M	I	T							31.2	E 8
9.4	16.7	20.2	29.8	32.6								

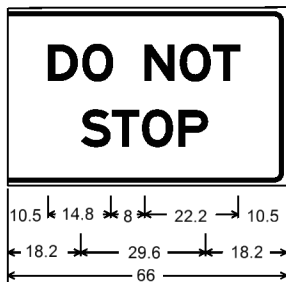

3.0" RADIUS, 1.3" BORDER, 0.8" INDENT, BLACK ON WHITE; [DO NOT] E 2K; [STOP] E 2K;

NOTE: DIAGRAM DIMENSIONS ARE IN INCHES

WIDTH x HGHT.	5'-6" x 3'-6"
BORDER WIDTH	1.25
CORNER RADIUS	3
MOUNTING	Overhead
BACKGROUND	TYPE: Reflective
	COLOR: White
LEGEND/BORDER	TYPE: Reflective
	COLOR: Black

LETTER POSITIONS (X)

LETTER POSITIONS (X)											LENGTH	SERIES/SIZE
D	O		N	O	T						47.0	E 8
10.5	18.6	26.6	33.3	41.6	49.5							
S	T	O	P								31.0	E 8
18.2	25.6	32.7	41.3									

SIGN DETAIL
N.T.S.

SP-12

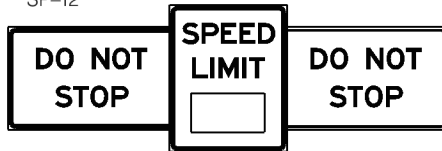

Maine Turnpike Authority

SIGN NUMBER SP-12

WIDTH x HGHT.	5'-6" x 3'-6"
BORDER WIDTH	1.25
CORNER RADIUS	3
MOUNTING	Overhead
BACKGROUND	TYPE: Reflective
	COLOR: White
LEGEND/BORDER	TYPE: Reflective
	COLOR: Black

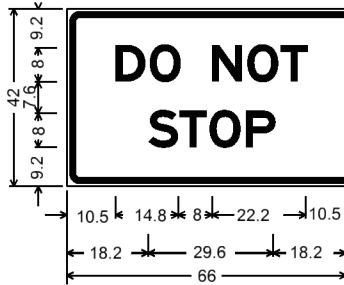

3.0" RADIUS, 1.3" BORDER, 0.8" INDENT, BLACK ON WHITE; [DO NOT] E 2K; [STOP] E 2K;
NOTE: DIAGRAM DIMENSIONS ARE IN INCHES

LETTER POSITIONS (X)

LETTER POSITIONS (X)											LENGTH	SERIES/SIZE
D	O		N	O	T						47.0	E 8
10.5	18.6	26.6	33.3	41.6	49.5							
S	T	O	P								31.1	E 8
18.2	25.6	32.7	41.3									

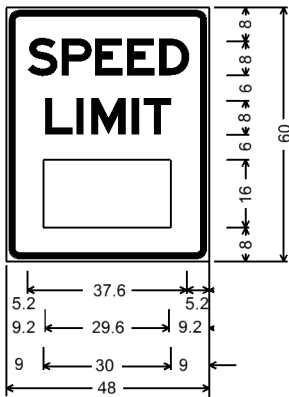

SYMBOL	X	Y	WID	HT
(DIGITAL DISPLAY)	9.0	8.0	30	16

3.0" RADIUS, 1.3" BORDER, 0.8" INDENT, BLACK ON WHITE; [SPEED] E 2K; [LIMIT] E 2K; [00] E 2K;
NOTE: DIAGRAM DIMENSIONS ARE IN INCHES

WIDTH x HGHT.	4'-0" x 5'-0"
BORDER WIDTH	1.25
CORNER RADIUS	3
MOUNTING	Overhead
BACKGROUND	TYPE: Reflective
	COLOR: White
LEGEND/BORDER	TYPE: Reflective
	COLOR: Black

LETTER POSITIONS (X)

LETTER POSITIONS (X)											LENGTH	SERIES/SIZE
S	P	E	E	D							39.1	E 8
5.2	13.3	21.1	28.7	36.3								
L	I	M	I	T							31.2	E 8
9.4	16.7	20.2	29.8	32.6								



3.0" RADIUS, 1.3" BORDER, 0.8" INDENT, BLACK ON WHITE; [DO NOT] E 2K; [STOP] E 2K;
NOTE: DIAGRAM DIMENSIONS ARE IN INCHES

WIDTH x HGHT.	5'-6" x 3'-6"
BORDER WIDTH	1.25
CORNER RADIUS	3
MOUNTING	Overhead
BACKGROUND	TYPE: Reflective
	COLOR: White
LEGEND/BORDER	TYPE: Reflective
	COLOR: Black

LETTER POSITIONS (X)

LETTER POSITIONS (X)											LENGTH	SERIES/SIZE
D	O		N	O	T						47.0	E 8
10.5	18.6	26.6	33.3	41.6	49.5							
S	T	O	P								31.0	E 8
18.2	25.6	32.7	41.3									

SIGN DETAIL
N.T.S.



**Maine
Turnpike
Authority**

SYMBOL	X	Y	WID	HT
2 AXLE CAR	40.0	5.1	8.5	3.0
CAR AND TRAILER	40.0	10.1	13.0	3.0
2 AXLE 6 WHEEL	40.0	15.1	6.0	3.0
3 AXLE COMB	40.0	20.1	8.5	3.0
4 AXLE COMB	40.0	25.1	9.5	3.0
5 AXLE COMB	40.0	30.1	10.0	3.0
6 AXLE OR MORE	40.0	35.1	14.5	3.0

SIGN NUMBER	SP-13 (SHEET 1 OF 2)
WIDTH x HGHT.	6'-6" x 4'-0"
BORDER WIDTH	1.25
CORNER RADIUS	12
MOUNTING	Ground
BACKGROUND	TYPE: Reflective
	COLOR: White
LEGEND/BORDER	TYPE: Reflective
	COLOR: Black

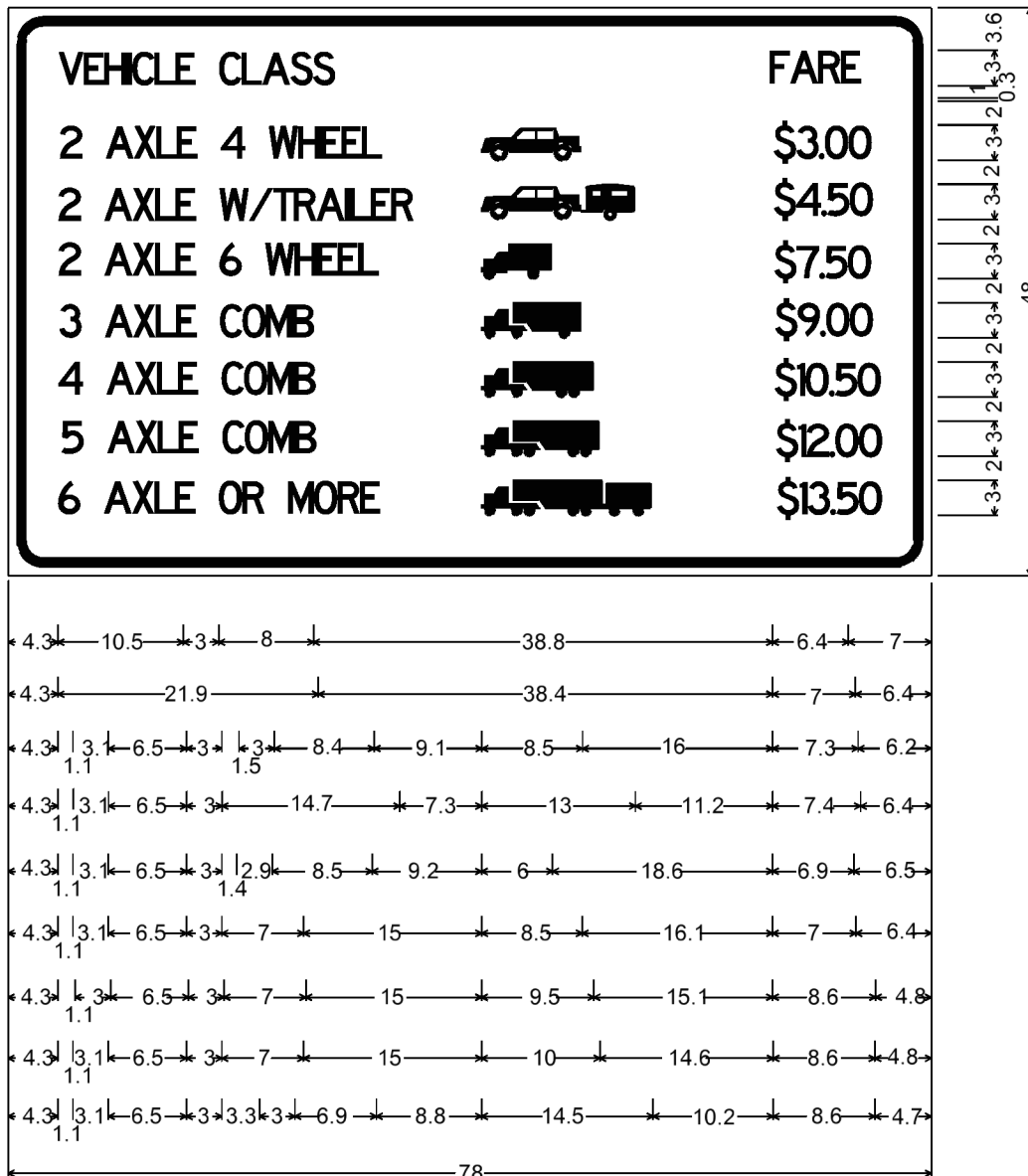

SIGN DETAIL
N.T.S.



**Maine
Turnpike
Authority**

NOTE: DIAGRAM DIMENSIONS ARE IN INCHES

SIGN NUMBER	SP-13 (SHEET 2 OF 2)
-------------	----------------------

LETTER POSITIONS (X)

LENGTH SERIES/SIZE

V	E	H	I	C	L	E		C	L	A	S	S				B
4.3	6.0	7.6	9.5	10.4	12.1	13.6	15.6	17.8	19.5	20.8	22.9	24.6	26.6			3
F	A	R	E													B
64.6	66.0	68.0	69.9											68.6		3
2		A	X	L	E		4		W	H	E	E	L			B
4.3	6.3	8.5	10.5	12.4	13.9	15.9	18.0	20.0	22.5	24.9	26.6	28.3	29.8	31.8		3
\$	3	.	0	0												B
64.6	66.4	68.0	68.6	70.5											68.6	3
2		A	X	L	E		W	/	T	R	A	I	L	E	R	B
4.3	6.3	8.5	10.5	12.4	13.9	15.9	18.0	20.1	22.4	24.0	25.8	27.8	28.6	30.3	31.9	3
	\$	4	.	5	0											B
33.9	64.6	66.4	68.1	69.0	70.6										68.6	3
2		A	X	L	E		6		W	H	E	E	L			B
4.3	6.3	8.5	10.5	12.4	13.9	15.9	18.0	20.0	22.4	24.6	26.5	28.0	29.6	31.6		3
\$	7	.	5	0												B
64.6	66.4	67.6	68.4	70.1											67.8	3
3		A	X	L	E		C	O	M	B						B
4.3	6.3	8.5	10.5	12.4	13.9	15.9	18.0	19.8	21.8	23.8	25.8					3
\$	9	.	0	0												B
64.6	66.4	67.8	68.5	70.3											68.6	3
4		A	X	L	E		C	O	M	B						B
4.3	6.3	8.5	10.5	12.4	13.9	15.9	18.0	19.8	21.8	23.8	25.8					3
\$	1	0	.	5	0											B
64.6	66.4	67.8	69.4	70.3	71.9										68.6	3
5		A	X	L	E		C	O	M	B						B
4.3	6.3	8.5	10.5	12.4	13.9	15.9	18.0	19.8	21.8	23.8	25.8					3
\$	1	2	.	0	0											B
64.6	66.4	67.8	69.5	70.1	71.9										68.6	3
6		A	X	L	E		O	R		M	O	R	E			B
4.3	6.3	8.5	10.5	12.4	13.9	15.9	18.0	20.0	22.0	24.3	26.3	28.1	30.0	32.0		3
\$	1	3	.	5	0											B
64.6	66.4	67.8	69.4	70.1	71.9										68.6	3
																B
																3
																B
																3

SIGN DETAIL
N.T.S.



**Maine
Turnpike
Authority**

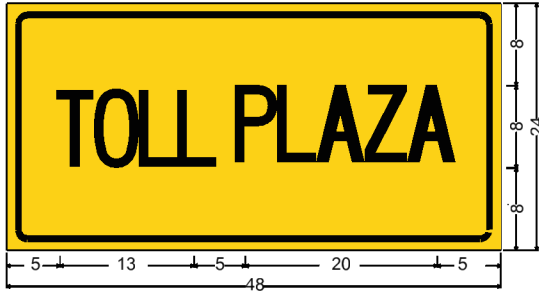

3.0" RADIUS, 0.6" BORDER, 0.5" INDENT, BLACK ON YELLOW;
[TOLL] B 10% SPACING; [PLAZA] B 10% SPACING;

NOTE: DIAGRAM DIMENSIONS ARE IN INCHES

SIGN NUMBER	SP-15
WIDTH x HGHT.	4'-0" x 2'-0"
BORDER WIDTH	1
CORNER RADIUS	3
MOUNTING	Ground
BACKGROUND	TYPE: Reflective
	COLOR: Yellow
LEGEND/BORDER	TYPE: Reflective
	COLOR: Black

SYMBOL	X	Y	WID	HT

LETTER POSITIONS (X)

LENGTH SERIES/SIZE

T	O	L	L		P	L	A	Z	A							B	
5.0	8.3	12.1	15.1	17.1	23.1	26.8	29.8	34.1	37.6							37.6	10

SIGN DETAIL
N.T.S.



**Maine
Turnpike
Authority**

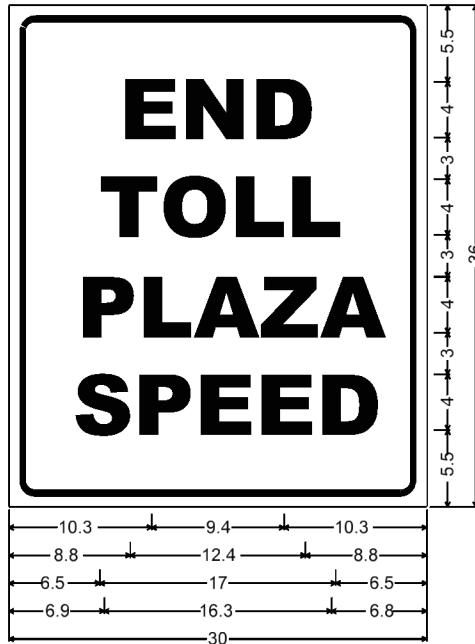

3.0" RADIUS, 0.8" BORDER, 0.5" INDENT, BLACK ON WHITE;
[END] D; [TOLL] D; [PLAZA] D; [SPEED] D;
NOTE: DIAGRAM DIMENSIONS ARE IN INCHES

SIGN NUMBER	SP-16
WIDTH x HGHT.	2'-6" x 3'-0"
BORDER WIDTH	1
CORNER RADIUS	3
MOUNTING	Ground
BACKGROUND	TYPE: Reflective
	COLOR: White
LEGEND/BORDER	TYPE: Reflective
	COLOR: Black

SYMBOL	X	Y	WID	HT

LETTER POSITIONS (X)

LENGTH SERIES/SIZE

E	N	D																				D		
10.36	13.4	17.1																				9.74	10	
T	O	L	L																				D	
8.8	11.9	15.6	18.9																				13.2	10
P	L	A	Z	A																			D	
6.5	10.1	12.9	17.0	20.1																			16.6	10
S	P	E	E	D																			D	
6.9	10.5	14.1	17.3	20.5																			16.6	10

SIGN DETAIL
N.T.S.



**Maine
Turnpike
Authority**

2.0" RADIUS, 0.6" BORDER, 0.4" INDENT, BLACK ON WHITE;
[NO U] C 2K;
[TURNS] C 2K;
NOTE: DIAGRAM DIMENSIONS ARE IN INCHES

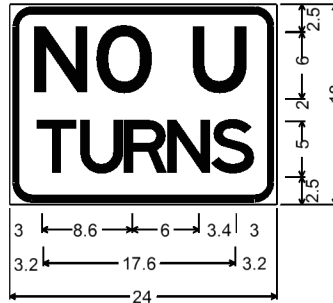

SIGN NUMBER	SP-17
WIDTH x HGT.	2'-0" x 1'-5"
BORDER WIDTH	0.6
CORNER RADIUS	2
MOUNTING	Ground
BACKGROUND	TYPE: Reflective
	COLOR: White
LEGEND/BORDER	TYPE: Reflective
	COLOR: Black

SYMBOL	X	Y	WID	HT

LETTER POSITIONS (X)

LENGTH

SERIES/SIZE

N	O		U															C	
2.9	7.5	11.5	17.0															19.1	6
T	U	R	N	S														C	
3.0	6.3	10.1	13.8	17.5														19.5	5

SIGN DETAIL
N.T.S.



**Maine
Turnpike
Authority**

SIGN NUMBER	SP-18
WIDTH x HGHT.	12'-0" x 4'-0"
BORDER WIDTH	1.3
CORNER RADIUS	12
MOUNTING	Overhead
BACKGROUND	TYPE: Reflective
	COLOR: White
LEGEND/BORDER	TYPE: Reflective
	COLOR: Black

12.0" Radius, 1.3" Border, Black on White;
 12.0" RADIUS, 2.0" BORDER, 2.0" INDENT, BLACK ON WHITE;
 [ANY VEHICLE] D 2K;
 [CASH / RECEIPTS] D 2K
 NOTE: DIAGRAM DIMENSIONS ARE IN INCHES

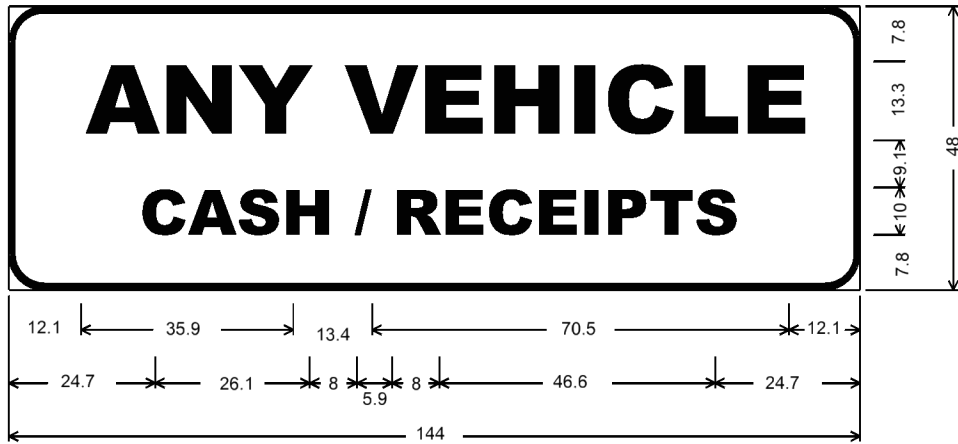

LETTER POSITIONS (X)

LENGTH SERIES/SIZE

A	N	Y		V	E	H	I	C	L	E					D	
12.3	25.6	36.6	46.6	63.9	73.6	84.1	96.4	101.5	113.5	123.8					123.5	13.3
C	A	S	H	/	R	E	C	E	I	P	T	S			D	
24.8	31.3	38.6	45.5	58.9	72.9	79.6	85.8	93.0	99.4	102.5	108.4	114.0			94.2	10

SIGN DETAIL
N.T.S.

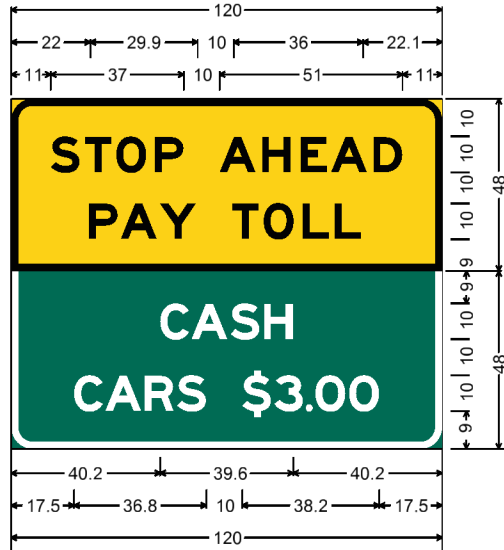

12.0" RADIUS, 2.0" BORDER, BLACK ON YELLOW;
 [STOP AHEAD] E MOD 2K;
 [PAY TOLL] E MOD 2K;
 6.0" RADIUS, 2.0" BORDER, WHITE ON GREEN;
 [CASH] E MOD 2K;
 [CARS \$3.00] E MOD 2K 50% SPACING;
 ARROW 80 - 25.0" 55°;
 NOTE: DIAGRAM DIMENSIONS ARE IN INCHES



Maine Turnpike Authority

SIGN NUMBER	W9-6B
WIDTH x HGHT.	10'-0" x 8'-0"
BORDER WIDTH	2
CORNER RADIUS	12
MOUNTING	Ground
BACKGROUND	TYPE: Reflective
	COLOR: Yellow / Green
LEGEND/BORDER	TYPE: Reflective
	COLOR: Black / White

SYMBOL	X	Y	WID	HT

LETTER POSITIONS (X)

LENGTH SERIES/SIZE

S	T	O	P		A	H	E	A	D										EMOD		
11.0	20.5	29.3	39.9	48.0	58.0	69.8	80.6	89.1	100.9										99.4	10	
P	A	Y		T	O	L	L												EMOD		
22.0	30.9	41.8	51.9	61.9	70.7	81.5	90.5												78.0	10	
C	A	S	H																EMOD		
40.2	49.5	61.1	71.7																41.0	10	
C	A	R	S		\$	3	.	0	0										EMOD		
17.5	26.2	37.2	46.2	54.3	64.3	73.2	82.0	84.7	94.1										86.1	10	

(This page left intentionally blank)

APPENDIX G

YORK WATER DISTRICT SPECIAL PROVISIONS

(This page left intentionally blank)

SPECIAL PROVISIONS
WATER MAINS AND APPURTENANCES
TABLE OF CONTENTS

Section	Specification Topic	Page Number
I.	Ductile Iron Pipes	SP - 2
II.	Ductile Iron Fittings	SP - 5
III.	Restrained Joints	SP - 7
IV.	Gate Valves	SP - 8
V.	Valve Boxes	SP - 9
VI.	Service Boxes	SP - 10
VII.	Hydrants	SP - 11
VIII.	Corporation Stops	SP - 12
IX.	Curb Stops	SP - 13
X.	Copper Service Line Tubing	SP - 14
XI.	M.J. Tapping Sleeves and Valves	SP - 15
XII.	Bolts and Nuts	SP - 15
XIII.	Service Saddles	SP - 16
XIV.	Stainless Steel Repair Clamps	SP - 16
XV.	Solid Sleeves	SP - 17
XVI.	Insulation	SP - 17
XVII.	Water / Sewer Crossings	SP - 17
XVIII.	Testing Requirements	SP - 18

STATEMENT OF INTENT

This policy outlines the minimum specifications for materials used in the installation and maintenance of **Water Mains and Appurtenances** for the York Water District. Unless directly specified in this document, equipment and materials shall meet all applicable AWWA, ANSI, NSF, ASTM, and State and Federal Standards. York Water District will not give authorization to the Contractor to perform any utility relocations that require temporary services if there is a risk of freezing. The York Water District (YWD) reserves the right to inspect, accept and reject any and all material to be used by the Contractor. A listing of all material and material suppliers will be submitted to YWD for approval prior to any construction. A pre-construction meeting shall be held prior to construction with all parties, unless otherwise waived by YWD.

I. **Ductile Iron Pipe**

1. Construction and Design:

- 1.1. All **Ductile Iron Pipe** shall be supplied in 20 foot lengths having Fastite® joints or equivalent as specified in ANSI/AWWA C111/A21.11 (for push on joints). Pipe shall be Class 52 unless otherwise specified, designed for a 350 psi rated working pressure and for laying condition type 4 (type 4 - flat bottom trench, backfill compacted to top of the pipe, and with up to eight (8) feet of cover). Pipe shall be manufactured in full conformance with ANSI/AWWA C151/A21.51 standards.
 - a. Special order pipe (mechanical joint or other) shall be furnished with standard gland, gaskets and Corten bolts and nuts as "standard accessories."
- 1.2. The interior of the pipe shall be double cement lined and seal coated to twice the thickness (2 mils) specified in ANSI A21.4 - A21.5 and AWWA C104 (for cement, mortar lining and seal coating).
- 1.3. The exterior of the pipe shall be bituminous asphalt coated to 1 mil thick as specified in ANSI/AWWA C151/A21.51 and shall be acceptable to the NSF for use in potable water. Field application of exterior coatings is prohibited. The finished coating shall be continuous, smooth, neither brittle when cold or sticky when exposed to the sun, and strongly adherent.
- 1.4. Pipe shall be furnished with gasket and gasket lubricants as "standard accessories".
- 1.5. Unless otherwise specified all **Ductile Iron Pipes** must be manufactured in The United States.
- 1.6. Approved manufacturers are American Pipe™ and U.S. Pipe™, or approved equal.

2. Installation:

2.1. Product Delivery, Storage and Handling

- a. Pipe and accessories shall be delivered, stored and handled in a manner consistent with the written recommendations of pipe manufacturer. Care shall be taken not to damage materials during delivery, storage and handling. Dropping of materials will not be permitted. Only approved "rated" sling, chain and or pipe grab shall be used for lifting and lowering pipe. Suitable buffers to protect the material shall be provided.

- b. Any materials found to be defective either before or after installation shall be removed from the job-site and replaced with sound materials.
 - c. Distribution of materials along the work area shall not be permitted, unless approved by the Owner. The Contractor shall not obstruct public or private areas such as but not limited to driveways, sidewalks, and walkways nor shall materials be placed on private property, unless written approval is obtained, beforehand, from said property owner.
- 2.2. Push on Joint pipe shall be assembled and installed in strict accordance with the manufacturer's instructions, in accordance with ANSI/AWWA C600, and as described below.
- a. Completely, clean the bell socket and insert the gasket, making sure that it faces the proper direction and that it is correctly seated.
 - b. After cleaning dirt or foreign material from the plain end, apply an approved lubricant in accordance with the pipe manufacturer's recommendations. The lubricant is supplied in sterile cans and every effort shall be made to keep it sterile.
 - c. Make sure that the plain edge is beveled, square or sharp edges may damage or dislodge the gasket and cause a leak. When pipe is cut in the field, bevel the plain end with a heavy file, grinder or pipe saw to remove all sharp edges.
 - d. Push the plain end of the pipe into the bell of the pipe. Keep the joints straight while pushing. Make deflection after the joint is assembled. Small pipe can be pushed into the bell socket with a long bar. Large diameter pipe (12" and greater) requires additional power, such as a pipe jack, lever or backhoe. A piece of wood blocking should be used between the pipe and jack or backhoe bucket to avoid damage to the pipe. Care should be taken to avoid "slamming" the pipe together potentially causing a joint failure.
- 2.3. Mechanical joint pipe shall be assembled and installed in strict accordance with the manufacturer's instructions, ANSI/AWWA C600, and as described below.
- a. Wipe-clean the socket and plain end. The plain end, socket, and gasket shall be washed with a soap solution to improve gasket seating. Place the gland on the plain end with the lip extension toward the plain end, followed by the gasket with the narrow edge of the gasket toward the plain end.
 - b. Insert the pipe into the socket and press the gasket firmly and evenly into the gasket recesses. Keep the joint straight during assembly. Make deflection after joint assembly but before tightening bolts.
 - c. Push the gland toward the socket and center it around the pipe with the gland lip against the gasket. Insert bolts and hand-tighten the nuts.
 - d. Tighten the bolts to the normal range of bolt torque (75-90 ft. lbs. for 4" to 24" diameter pipe), while at all times maintaining approximately the same distance between the gland and the face of the flange at all points around the socket. This can be accomplished by partially tightening the bottom bolt first, and then the top bolts. Repeat the process until all bolts are within the appropriate range of torque. Generally 3 to 4 repetitions are required.

- e. If installing into a Push on bell, make sure that the plain edge is beveled. Square or sharp edges may damage or dislodge the gasket and cause a leak. When pipe is cut in the field, bevel the plain end with a heavy file, grinder or pipe saw to remove all sharp edges.
- 2.4. For other types of pipe joints that may be specified for "specialty" type jobs, specific instructions will be given as needed.
- 2.5. Pipe cleanliness - Foreign material shall be prevented from entering the pipe while it is being placed in the trench. No debris, tools, clothing, or other material shall be placed in the pipe at any time.
- 2.6. Pipe placement - As each length of pipe is placed in the trench, the joint shall be assembled and the pipe brought to correct line and grade. The pipe shall be held in place via blocking behind the bell prior to back filling. Any blocking used will be removed after chinking pipe into place.
- 2.7. Direction of bells - It is common practice to lay pipe with the bells facing the direction in which work is progressing.
- 2.8. Temporary pipe plugs - The open end of the pipe shall be closed with a watertight plug or by other means acceptable to the District. When practical, the plug shall remain in place until the trench is pumped completely dry. Care must be taken to prevent pipe movement should the trench fill with water. Pipe plugs shall be used when pipe laying operations stop for the day or for a prolonged period of time. Also, during daily installation of pipe, watertight plus must be inserted while digging for the next length.
- 2.9. Pipe deflection - When it is necessary to deflect pipe from a straight line in either the horizontal or vertical plane, the amount shall not exceed 75% of the maximum allowable deflection as specified by the manufacturer. For example, for 12" DI push on pipe, the maximum allowable deflection is 5° or 21 " for a 20' length of pipe. Therefore, the District will permit 75% of 21" or 15" maximum deflection per joint. Please keep in mind that deflections are cumulative in the horizontal and vertical plane.
- 2.10. Polyethylene encasement - Polyethylene encasement of DI pipe shall be done, when specifically specified, in accordance with ANSI/AWWA C105/A21.5.
- 2.11. Pipe Bedding - AWWA Type 4 bedding conditions will be maintained during pipe installation. Trenches shall be flat bottomed, with 6" of compacted sand beneath and 12" above the pipe. Where ledge is encountered, 12" of compacted sand shall be installed beneath the pipe. The trench will be kept dewatered during pipe laying.
 - a. Bedding shall be clean granular sand, free from organic matter, frozen material or any other objectionable material and shall meet the following requirements:
 - 100% passing a 3/4-inch sieve
 - 70-100% passing a #4 sieve
 - 0-5% passing a No. 200 mesh sieve

- 2.12. Trench Backfill - There shall be a minimum of 5' of cover over the installed pipe.
 - a. The remaining depth of trench will be backfilled with clean existing material suitable to the YWD Inspector on the job; excluding particularly large blasted ledge, rocks over 12" in diameter, organic or peat material, or other objectionable material. No manufactured or recycled materials, including emulsified asphalt products, will be allowed as backfill.
 - b. Backfill materials under roadways shall conform to the current requirements found in Section 9.7 Street Construction Standards of the Town of York Site Plan and Subdivision Regulations or as directed by the Town of York Department of Public Works. Backfill material above sand bedding layer and below roadway gravels shall be gravel or clean backfill material meeting Maine DOT Specification 703.20 Gravel Borrow. Diagram: (See Typical Trench Detail)
- 2.13. Compaction – All fills shall be compacted sufficiently so that structures or paving shall not settle and so that they shall not allow movement of earth and shall prevent subsequent settlement.
 - a. All percentages of compaction specified herein shall be of the maximum dry density at the optimum moisture content as established by Method D of AASHTO Standard T180 (ASTM D1557) (Modified Proctor).
 - b. The owner reserves the right to have additional compaction tests performed by an independent laboratory with testing costs borne by the owner.
 - c. Where excavated material is used for backfill, 12" lifts shall be compacted to the native surrounding soil density.
 - d. Where borrow is used, 12" lifts shall be compacted to not less than an in-place density of 90%. Under roadways, compaction shall be not less than 95%.
 - e. Gravel Base shall be placed in no greater than 6" lifts and shall be compacted to not less than an in-place density of 95%.

II. Ductile Iron Fittings (bends, reducers, off-sets, tees, and sleeves)

1. Construction and Design:

- 1.1. Fittings shall be compact Ductile Iron Class 350 with mechanical joint ends. **Fittings shall** conform to ANSI Specifications A21.10, A21.4, A21.53, and A21.11C, and AWWA C110, C111, C153, and C104 for applicable fittings in size 4" through 24". All fittings shall be of standard grade 70-50-05 ductile iron construction with the following minimum characteristics
 - a. 70,000 psi minimum tensile strength
 - b. 50,000 psi minimum yield strength
 - c. 5% minimum elongation
- 1.2. Push on fittings will not be accepted without prior approval from the District.
- 1.3. Mechanical joint nuts shall be Corten, high strength, low alloy steel per ANSI A21.11.

- 1.4. Cast iron fittings are not permitted.
 - 1.5. Standard and Flanged Joint fittings will not be accepted without prior approval. Accepted fittings in these categories will meet the following minimum specifications:
 - a. Mechanical Joint Standard fittings shall be D.I. Class 350 in accordance with ANSI Specifications A21.10, A21.4, A21.53, and A21.11C, and AWWA C110, C111, C153, and C104 for applicable fittings in size 4" through 24".
 - b. Flanged Joint fittings shall be D.I. Class 250 in accordance with ANSI Specifications A21.10, A21.4, A21.53, and A21.11C, and AWWA C110, C111, C153, and C104 for applicable fittings in size 4" through 24".
 - 1.6. All **Fittings** shall be cement lined with a minimum 1/16" thickness and coated inside with a minimum 4 mils film thickness. The outside shall be bituminous coated with a minimum 4 mils dry film thickness. The finished coating shall be continuous, smooth, neither brittle when cold or sticky when exposed to the sun, and strongly adherent to the fitting.
 - 1.7. Fittings must be Tyler™, or pre-approved equal.
 - 1.8. All fittings will be supplied with grip rings for pipe diameters 12" and smaller and Roma Grips for pipes 16" and larger unless otherwise specified. Mechanical joint accessories shall be ductile iron glands, which conform to A536. All sizes shall be underwriters laboratory listed 877P. Mechanical joints shall also include Grip Rings™ accessory packs. Glands shall be painted yellow.
 - 1.9. Unless otherwise specified all **Ductile Iron Pipe Fittings** must be manufactured in The United States.
2. Installation:
- 2.1. All fittings shall be inspected prior to installation to ensure the gasket seats are free of excess coatings. Excess coating, if present, shall be manually removed so as to ensure proper seal of the gasket, however, all bare metallic surfaces created as a result of removing the excess coating shall be re coated with similar material to prohibit corrosion.
 - 2.2. The fittings shall be placed, supported and installed in strict accordance with the manufacturer's instructions and as directed by the YWD (See Figure Typical Thrust Block Placement on Bends, Fittings, etc.). All bolted joints shall be torqued as follows:
 - a. Mechanical Joints 4" - 24" diameter pipe:
 - 3/4" bolts - torque = 75 to 90 ft. lbs.
 - b. Flanged Joint 4" - 24" diameter pipe:
 - 5/8" bolts - torque = 40 to 60 ft. lbs.
 - 3/4" bolts - torque = 60 to 90 ft. lbs.
 - 7/8" bolts - torque = 40 to 60 ft. lbs.
 - 1" bolts - torque = 40 to 60 ft. lbs.
 - 1 1/4" bolts - torque = 40 to 60 ft. lbs.

- 2.3. Procedure for installing bolts -
 - a. Insert bolts and make finger tight.
 - b. Tighten diametrically opposite nuts progressively and uniformly around joint with properly calibrated torque wrench to the valves as specified above.
 - c. Coat all bolt threads for flanged connections with "never-seize" or an approved equal product.

III. Restrained Joints

1. Construction and Design:

- 1.1. **Restrained Joints** shall be used at all pipe joints, fittings, valves, etc. Mechanical joint restraints shall be incorporated in the design of the follower gland and shall include a restraining mechanism which, when actuated, imparts multiple wedging action against the pipe, increasing its resistance as the pressure increases. Flexibility of the pipe shall be maintained after burial.
- 1.2. Mechanical joint nuts and bolts shall be Corten™, made of high strength, low alloy steel and conform to AWWA C-111, 11-7.5 and ANSI A21.11. Mechanical joint nuts and bolts shall be composed of a maximum of .20% carbon, 1.25% manganese, .05% sulfur, .25% nickel, 20% copper, and a minimum combined 1.25% of nickel, copper and chromium. The mechanical joint nuts and bolts shall also have a minimum yield strength of 45,000 psi and elongation in 2" increments of 20%.
- 1.3. Mechanical Joint gaskets shall comply with AWWA C-111 and ANSI A21.11 for SBR gaskets. Glands shall be manufactured of ductile iron, heat treated to a minimum hardness of 370 BHN. Dimensions of the gland shall be such that it can be used with the standardized mechanical joint bell and "T" - head bolts conforming to ANSI/AWWA C 153/A21.53 of latest revision.
- 1.4. The mechanical joint devices shall have a working pressure of at least 350 psi, with a minimum safety factor of 2: 1.
- 1.5. The mechanical **Restrained Joints** shall be Grip-Ring™, manufactured by Romac Industries.
- 1.6. Unless otherwise specified all **Restrained Joints** must be manufactured in The United States or Canada.

2. Installation:

- 2.1. All **Restrained Joints** shall be thoroughly inspected for cracks or similar physical defects prior to their installation.
- 2.2. All joints, both newly installed and existing, are to be restrained for a minimum distance of 18 feet beyond each side of a fitting or valve including the joints at **the fitting** or valve, or as otherwise show on the construction plans. Restrained lengths beyond the minimum are to be based on a 200 psi working pressure, 5-foot depth of cover, and actual soil conditions encountered.

- 2.3. The **Restrained Joints** shall be installed in strict accordance with the manufacturer's instructions and as directed by the YWD. All bolted joints shall be torqued as follows:
- a. Mechanical Joints 4" - 24" diameter pipe:
 - 3/4" bolts - torque = 75 to 90 ft. lbs.
 - b. Flanged Joint 4" - 24" diameter pipe:
 - 5/8" bolts - torque = 40 to 60 ft. lbs.
 - 3/4" bolts - torque = 60 to 90 ft. lbs.
 - 7/8" bolts - torque = 40 to 60 ft. lbs.
 - 1" bolts - torque = 40 to 60 ft. lbs.
 - 1 1/4" bolts - torque = 40 to 60 ft. lbs.
- 2.4. Procedure for installing bolts -
- a. Insert bolts and make finger tight.
 - b. Tighten diametrically opposite nuts progressively and uniformly around joint with properly calibrated torque wrench to the valves as specified above.
 - c. Coat all bolt threads for flanged connections with "never-seize" or an approved equal product.

IV. Gate Valves

1. Construction and Design:

- 1.1. **Gate valves** shall be Ductile Iron body, bronze mounted, resilient wedge gate with two inch operating nut and mechanical joint ends. Minimum body thickness and design must meet or exceed AWWA standard C515 Gate valves shall conform to AWWA C515
- 1.2. Exterior nuts and bolts shall be 5/8" diameter or greater and shall be type 18-8, 304 stainless steel, installed by the manufacturer. Exterior nuts and bolts shall meet ASTM F593, GP 1.
- 1.3. Wedges shall be constructed of Ductile Iron, fully encapsulated in synthetic rubber per AWWA C-509. Wedge rubber shall be molded in place and bonded to the Ductile Iron portions. Under no circumstances shall rubber be mechanically attached with screws or other fastening devices. Wedges shall seat against seating surface arranged symmetrically about the center line of the operating stem so that seating is equally effective regardless of direction of pressure imbalance across the wedge.
- 1.4. All seating surfaces shall be inclined a minimum angle of 32° from vertical, to eliminate abrasive wear of rubber sealing surfaces. Waterways shall be smooth and shall have no depressions or cavities in the seat area where foreign materials can lodge and prevent closure or sealing.
- 1.5. All **valves** shall be provided with three "O" rings to seal the stem. The design of the **valve** shall be such that the stem seals, above the thrust collar, can be fitted can

be fitted with new "O" rings while the valve is under full working pressure in a fully open position.

- 1.6. Stems shall be constructed from rolled stainless steel, type 304 or higher. Bronze stems may be substituted with the permission of the District.
 - 1.7. **Valve** interiors and exteriors shall have a 100% solids thermoset or fusion bonded epoxy protective coating throughout, holiday-free in the waterway, which shall meet all requirements of AWWA C550. The coatings shall be a product approved by NSF for use in potable water and shall be so listed in the most current NSF summary of approved products ANSI/NSF Standard 61. The valve manufacturer, under controlled factory conditions shall apply the coating, and under no circumstances shall a field application be permitted.
 - 1.8. All valves must be open left, close right and have a full ten-year Warranty.
 - 1.9. Unless otherwise specified all **Gate valves** must be manufactured in The United States.
 - 1.10. **Gate valves** shall be American Flow Control™ Model 2500, or pre approved equal manufacturer.
2. Installation
- 2.1. Blocking, set on thoroughly compacted soil, shall be used to support the valve body during installation.
 - 2.2. All joint bolts shall be torqued using a calibrated torque wrench in accordance with the manufacturer's specifications.
 - 2.3. Care should be taken to ensure that the fusion-bonded epoxy coating is not damaged. Any damaged areas shall be repaired.

V. Valve Boxes

1. Construction and Design:

- 1.1. **Valve boxes** shall be Cast Iron, tar coated, two piece, and sliding type adjustable with Cast Iron covers. **Valve boxes** shall have a top flange. The bell end of the lower sections shall in all cases be sufficiently large to fit over the stuffing boxes of the valves. The smallest inside diameter of the shaft shall not be less than 5-1/4 inches. Unless specified directly, the top section will be 26" and the bottom will be 36" bell.
- 1.2. The upper section shall have a flange sufficiently strong to furnish the bearing for that section so that all weight or jolting from street traffic or the like shall not be transmitted to the valve. Each valve box, including cover shall weight at least 100 pounds.
- 1.3. The cover shall be heavy 2" drop type, non-tilting cast iron unit that is recessed in the top to prevent breakage. The cover shall be provided with two pick holes for easy removal. The word "WATER" shall be cast into the cover
- 1.4. All valves box components shall be generously coated with a corrosion resistant bituminous coating.
- 1.5. Unless otherwise specified all **Valve boxes** must be manufactured in The United States or Canada.

2. Installation:
 - 2.1. **Valve boxes** shall be installed concentric to the operating nut and shall be centered in the bell end. Boxes shall be plumb with the vertical plane.
 - 2.2. 6" of crushed stone shall be placed around the bell base of the valve box.
 - 2.3. The bell base section shall be placed on blocking in such a way that no additional loading is transferred to the valve.
 - 2.4. Additional extensions for bury depths greater than 6 feet shall be specified.

VI. Service Boxes

1. Construction and Design:
 - 1.1. **Service boxes** shall be Erie™ style with a plug type cover. **Service boxes** shall be constructed of 1.0 inch I.D. iron pipe with the top having 1.0 inch N.P.T. threads for a screw on cover. The box will be supplied in a 5'-6' bury with a slide type riser.
 - 1.2. All boxes shall be heavily coated with bituminous paint.
 - 1.3. Service Box Cover -
 - a. The cover shall be cast iron construction with N.P.T. female threads to accept the service box and will have a solid brass plug with a pentagon operating head and a 1" course "rope" thread.
 - 1.4. Service Box Rod -
 - a. A circular 1/2"(or larger) x 24", 304 stainless steel Service Box Rod shall be required. The design of the rod must have a yoke that is an integral part of the rod and be self-aligning. 5/8" x 24" s.s. service box rod to be used on all 1 1/2" and larger service valves.
 - b. The curb stop cotter pin shall be brass to minimize the danger of damaging the curb stop.
 - c. The rod "wrench-flat" shall have a minimum thickness of 1/4" tapered to 1/16" and width of 5/8" or 1/2".
 - 1.5. Service Box Foot Piece -
 - a. The standard foot piece shall be heavy-duty cast iron design. The foot piece shall be designed to have an arch to fit over either 3/4" or a 1" curb-stop, depending on the installation. All 1 1/2" & 2" ball-valve curb-stops shall utilize the addition of a HD footpiece.
 - 1.6. Unless otherwise specified all **Service boxes** must be manufactured in The United States or Canada.
2. Installation:
 - 2.1. Service box foot pieces shall be placed on compacted sand that supports the Curb Stop (see IX. Curb Stops, Section B, and Subsection i.).
 - 2.2. Service box tops shall be set 1" below finished grade, magnetized, and painted fluorescent blue prior to burial.
 - 2.3. A minimum of two (2) lateral "ties" shall be taken from permanent fixtures such as house corners, **fire** hydrants, etc., to the box top for the purpose of future location.

These ties shall be recorded in sketch form and compared with the measurements taken from the corresponding curb stop.

- 2.4. When installation is complete, no pressure shall be exerted by the curb box on either the curb stop or service pipe.

VII. Hydrants

The Contractor shall not reuse any hydrant without the approval of the York Water District. Any damage caused by the Contractor to YWD property and facilities, including but not limited to hydrants, shall be replaced at the Contractor's expense. Any hydrant that cannot be reused shall remain the property of the YWD. YWD reserves the right to provide the Contractor with replacement hydrants if so desired. All hydrants shall be salvaged in working condition.

1. Construction and Design:

- 1.1 Fire hydrants shall meet or exceed ANSI/AWWA C502, latest revision. Rated working pressure shall be 250 psig, test pressure shall be 500 psig and hydrants shall include the following specific design criteria: The nozzle section, upper and lower stand pipes and hydrant base shall be ductile iron.
- 1.2 External surfaces above grade shall be factory coated with an epoxy primer and a two-part polyurethane top coating.
- 1.3 The main valve closure shall be of the compression type, opening against the pressure and closing with the pressure. Nozzle section to be designed for easy 360° rotation by the loosening of no more than four bolts.
- 1.4 The valve opening diameter shall be 5-1/4". Hydrant must be designed so that removal of all working parts can be accomplished without excavating. The bronze seat shall be threaded into mating threads of bronze for easy field repair.
- 1.5 Bolting below grade shall be stainless steel.
- 1.6 Hydrant to be non-draining.
- 1.7 Hydrant must have an internal travel stop nut located in the top housing of the hydrant.
- 1.8 Hydrant operating threads to be factory lubricated. O-rings shall be furnished to help keep operating threads lubricated and protected from line fluid and from the weather.
- 1.9 Hydrant must have a traffic flange design allowing for quick and economical repair of damage resulting from a vehicle's impact.

Hydrants shall be AMERICAN Flow Control's **Waterous Pacer (Model WB67-250** classic head or long barrel style) is YWD's required hydrant.

Unless otherwise specified all **hydrants** must be manufactured in The United States.

2. Installation: (See Hydrant and Valve Detail)

VIII. Corporation Stops

1. Construction and Design:

- 1.1. All fittings and valves shall be manufactured in accordance with AWWA Standard C-800, latest revision, and as further specified in these provisions. If requested, an affidavit certifying compliance with the standards and specifications in these

provisions shall be signed and submitted by the manufacturing firm's Quality Assurance or Engineering Manager.

- a. Any brass part of the fitting or valve in contact with potable water shall be made of a "No-Lead Brass" defined for this specification as UNS Copper Alloy No C89833 or C89520 in accordance with the chemical and mechanical requirements of ASTM B584 and AWWA C-800. This "No-Lead Brass" alloy shall not contain more than 0.09% total Lead content by weight.
 - b. Any brass part of the fitting or valve not in contact with potable water shall be made of 85-5-5-5 brass as defined for this specification as UNS Copper Alloy C83600 per ASTM B62, ASTM B584 and AWWA C-800.
- 1.2. All brass fittings and valves shall be certified by an ANSI accredited test lab per ANSI/NSF Standard 61, Drinking Water Components – Health Effects, Section 8. Proof of certification is required. The lead content of the wetted components in contact with potable water, shall also be verified by an ANSI accredited test lab.
 - 1.3. Brass fittings and valves shall comply with the United States Of America Safe Drinking Water Act, and the U.S. Environmental Protection Agency.
 - 1.4. All brass fittings and valves shall have the manufacture's name or trademark permanently stamped or cast on it. Another marking identifying the "no lead" brass alloy, e.g., 'NL', shall be cast or permanently stamped on the fitting.
 - 1.5. **Corporation Stops** shall be of the 1/4 turn ball valve type. a "
 - 1.6. The ball mechanism shall be constructed of Teflon™ (TFE) coated brass and provide a full port opening.
 - 1.7. The inlet shall have AWWA (CC) taper threads.
 - 1.8. Outlet connections shall be compression pack joints (CPPJ), for either a compression pack joint (PJ) for copper or 200 psi CTS plastic on the outlet. CPPJ corporations shall be designed such that the PJ nut "shoulders" tight against the corporation valve body.
 - 1.9. The valve stem shall be provided with either EPDM or double Nitrile (Buna-N) O ring seals, 70 Durometer, to insure a permanent water tight seal. The ball seats shall also be either EPDM or molded Buna-N rubber. Seals shall be put into place with an NSF approved epoxy.
 - 1.10. Rated working pressure shall be 300 psi or greater.
 - 1.11. Acceptable manufacturers are McDonald and Ford (F1000), or pre approved equivalent equal.
 - 1.12. Unless otherwise **specified** all **Corporation Stops** must be manufactured in The United States.
2. Installation:
 - 2.1. The YWD only permits 1" diameter direct tapped ball corporation into cast iron and ductile iron mains. Larger diameter direct tapped corporations will be evaluated on an individual, case by case, basis.

- 2.2. Ball Corporation taps shall be located at 10:00 and 2:00 o'clock on the main.
- 2.3. Ball Corporations shall be "screwed" into ductile iron pipe water mains such that no more than 4 threads are exposed, and shall be otherwise installed in strict accordance with manufacturer's latest published recommendations.
- 2.4. A minimum of two (2) lateral "ties" shall be taken from permanent fixtures such as house comers, fire hydrants, etc., to the corporation for the purpose of future location. These ties shall be recorded in sketch form and submitted to the District prior to final acceptance.

IX. Curb Stops

1. Construction and Design:

- 1.1. All fittings and valves shall be manufactured in accordance with AWWA Standard C-800, latest revision, and as further specified in these provisions. If requested, an affidavit certifying compliance with the standards and specifications in these provisions shall be signed and submitted by the manufacturing firm's Quality Assurance or Engineering Manager.
 - a. Any brass part of the fitting or valve in contact with potable water shall be made of a "No-Lead Brass" defined for this specification as UNS Copper Alloy No C89833 or C89520 in accordance with the chemical and mechanical requirements of ASTM B584 and AWWA C-800. This "No-Lead Brass" alloy shall not contain more than 0.09% total Lead content by weight.
 - b. Any brass part of the fitting or valve not in contact with potable water shall be made of 85-5-5-5 brass as defined for this specification as UNS Copper Alloy C83600 per ASTM B62, ASTM B584 and AWWA C-800.
- 1.2. All brass fittings and valves shall be certified by an ANSI accredited test lab per ANSI/NSF Standard 61, Drinking Water Components – Health Effects, Section 8. Proof of certification is required. The lead content of the wetted components in contact with potable water, shall also be verified by an ANSI accredited test lab.
- 1.3. Brass fittings and valves shall comply with the United States Of America Safe Drinking Water Act, and the U.S. Environmental Protection Agency.
- 1.4. All brass fittings and valves shall have the manufacture's name or trademark permanently stamped or cast on it. Another marking identifying the "no lead" brass alloy, e.g., 'NL', shall be cast or permanently stamped on the fitting.
- 1.5. **Curb Stops** shall be of the left open 1/4 turn ball valve type in 1" to 2" body sizes and have full depth female iron pipe (FEIP) thread ends.
- 1.6. Outlet connections shall be compression pack joints (CPPJ), for either a compression pack joint (PJ) for copper or 200 psi CTS plastic on the outlet. CPPJ ball valve shall be designed such that the PJ nut "shoulders" tight against the ball valve body.
- 1.7. The ball mechanism shall be constructed of Teflon™ (TFE) coated brass and provide a full port opening.

- 1.8. The valve stem shall be provided with either EPDM or double Nitrile (Buna-N) O ring seals, 70 Durometer or greater, to insure a permanent water tight seal. The ball seats shall also be either EPDM or molded Buna-N rubber. Seals shall be put into place with an NSF approved epoxy. The operating cap/stem shall be held in place with a brass retaining nut threaded on to the stem and epoxied.
- 1.9. Rated working pressure shall be 300 psi or greater.
- 1.10. The **Curb Stop** shall not have a drain (waste) hole.
- 1.11. Acceptable manufacturers are McDonald, Ford, or pre-approved equivalent equals.
- 1.12. Unless otherwise specified all **Curb Stops** must be manufactured in The United States.

2. Installation:

- 2.1. Curb stop ball valves shall be firmly supported on compacted sand, set plumb and positioned such that the operator key is in the vertical plane prior to backfilling.
- 2.2. All curb stop ball valves shall be installed with YWD approved services boxes (see Service Box Specifications) and accessories, unless otherwise specified.
- 2.3. Prior to backfilling, the curb stop ball valve shall be placed under the applicable AWWA/ANSI static head pressure test unless otherwise waived by the District.
- 2.4. YWD personnel will inspect all private line connections to YWD facilities. The Contractor is responsible for the coordination of all such inspections.

X. Copper Service Line Tubing

1. Construction and Design:

- 1.1. Underground service line shall be seamless Type K malleable copper tubing that conforms to ASTM Standard B-88 and the latest revision of AWWA Standard C800.

2. Installation:

- 2.1. Extreme care shall be taken during installation to ensure that copper tubing is not crimped, gouged or otherwise detrimentally damaged.
- 2.2. The use of couplings shall be minimized by using the longest continuous coils available for the specific job. Under no circumstances are compression fittings to be used in the roadway portion of the installation.
- 2.3. Approved compression style joints shall be used for all pipe connections. Under no circumstances will soldering of underground copper tubing joints be permitted.
- 2.4. Copper tubing ends shall be de-burred and re-rounded prior to installing fittings to ensure strong, water tight connections.
- 2.5. Bedding material shall be sand.
- 2.6. The District will determine line size.

XI. M.J. Tapping Sleeves and Valves

Standards – (Use latest revisions)

1. Steel Pipe Flanges for Waterworks Service ANSI/AWWA C207
2. Drinking Water System Components – Health Effects

NSF/ANSI 61 Options and Modifications to the Standards

1. Materials in contact with potable water shall be certified NSF/ANSI 61 per the standard.
2. For size on size taps a ductile iron tapping sleeve is required, for tap diameters smaller than supply main diameter stainless steel sleeves are permitted.
3. Tapping sleeves shall conform to AWWA C-207, Class D, with rated maximum working pressure of 200 psi.
4. All sleeve and flange outlet bolts shall be stainless steel Type 304.
5. All surfaces not stainless steel shall be bituminous coated with a minimum of 4 mils dry film thickness or fusion bonded epoxy coated.
6. The sleeve shall be provided with a 3/4" F.I.P.T. test port and brass plug for ductile and 304 ss plug for stainless steel sleeves.
7. Stainless steel tapping sleeves shell shall be type 304 MIG welded and fully passivated.
8. Stainless steel tapping sleeves shall have a ductile iron flange welded to the neck.
9. Acceptable Manufacturers

1. Stainless steel tapping sleeves: Romac SST series,
2. Unless otherwise specified all **Tapping Sleeves** must be manufactured in The United States.

XII. Bolts and Nuts

1. Construction and Design:

1.1. **Bolts and nuts** shall be either Type 316 Stainless Steel or Corten Steel, depending on the application (see individual specifications).

a. **316 Stainless Steel** contains the addition of Molybdenum, to nickel - chromium steels with the following chemical composition:

- Carbon - .08% max.
- Manganese - 2.00% max.
- Silicone - 1.00% max.
- Phosphorus - .04% max.
- Sulfur - .03% max.
- Chromium - 16-18.00%

- Nickel - 10-14.00%
- Molybdenum - 2-3.00%
- SAE No. - 30316
- AMS No. - 5361A, 5524A, 5573, 5648B, 5690D

b. **Corten Steel** is the trade name for cold formed T-Head bolts containing alloying elements such as copper, nickel, and chrome, with the following chemical composition;

- Carbon - .20% max.
- Manganese - 1.25% max.
- Sulfur - .05% max.
- Nickel - .25% max.
- Copper - .20% max.
- Combined (Ni, Cu, Cr) - 1.25% min.

XIII. Service Saddles

1. Construction and Design:

- 1.1. The **service saddle** shall be Ductile Iron construction meeting ASTM A536-80, Grade 65-45-12, or type 304 stainless steel construction, and nylon coated to 10 mils thickness (not shop coat painted). There shall be two holding bands, U-bolt type, made of 304 or 316 stainless steel with Teflon coated threads.
- 1.2. Threads on the stainless steel U-bolts shall be CC (AWWA) or FEIP
- 1.3. The sealing gasket(s) shall be virgin NBR rubber (ASTM D2000) compounded for water and sewer service.
- 1.4. All nuts and Washers shall be Type 304 stainless steel according to YWD specifications.

2. Installation:

- 2.1. The use of **Service Saddles** by other than York Water District personnel is strictly prohibited.

XIV. Stainless Steel Repair Clamps

1. Construction and Design:

- 1.1. Stainless Steel Repair Clamps shall be SS I - single section or SS2 - double section, constructed of 304 (18-8) stainless steel with Teflon coated, rolled 5/8" N.C. thread bolts, and be 16" in length.
- 1.2. Nuts, bolts and sidebars shall be nylon coated, heavy gauge 304 (18-8) stainless steel.
- 1.3. Lifter bars will be heavy gauge 304 (18-8) stainless steel, TIG/MIG welded with chemical passivation of all welds, and have a lip curve to hold the bolts in place while tightening the clamp.
- 1.4. A self-lubricating washer will be between the hex nut and lifter bar assembly. Gaskets will be full length, meeting ASTM D2000-(AA415) and have grids in a

square pattern and tapered ends, made of virgin SRB rubber compounded for water service.

- 1.5. Single bolt "leak" type clamps will not be accepted.
2. Installation:
 - 2.1. Stainless steel repair clamps shall be used as a temporary repair. All permanent repairs shall be conducted by replacing the damaged section with a new section of the applicable size D.I. pipe (see specification) and joined to the existing sections with the appropriate solid sleeves.
 - 2.2. The use of **Stainless Steel Repair Clamps** by other than York Water District personnel is strictly prohibited.

XV. Solid Sleeves

1. Construction and Design:
 - 1.1 Solid sleeves shall be long body type, ductile iron with mechanical joint ends. All sleeves shall conform to the weights and dimensions shown in the latest edition of the DIPRA Handbook of Ductile Iron Pipe and come complete with all joint accessories.

XVI. Insulation

1. Construction and Design:
 - 1.1 Extruded polystyrene board insulation shall be used for water main and water services where required. The insulation shall be rigid, closed-cell, extruded polystyrene board complying with FS-HH-I-524, Type II, Class B; 30 psi compressive strength; 1.0 perm per inch maximum water absorption; thermal conductivity (K-value at 75 degree Fahrenheit) of 0.20; manufacturer's standard sizes, thickness shall be 2 inches.

XVII. Water / Sewer Crossings

1. Construction and Design:
 - 1.1. Anytime a sewer line is above a water main, the section of sewer pipe must be replaced with a full section of SDR-21 quality pipe. The full section of SDR-21 pipe shall be centered upon the crossing to maximize joint distance from the water main.
 - 1.1. GPK Products, Inc. SCH. 40 x SDR-35 G "No Stop" adapters must be used for all SDR-35 to SDR-21 connections. Connections of SDR-21 to other types of sewer pipe shall use solid couplings and must be approved by the York Sewer and Water Districts. Flexible couplings will not be permitted.
2. Installation:
 - 2.1. The full section of SDR-21 pipe shall have a minimum clearance of 18" above the water main.
 - 2.2. All alterations of sewer lines must be inspected by York Sewer District prior to backfilling.

XVIII. Testing Requirements

- 1.1. Flushing - All work shall be performed by the YWD only. The contractor is not permitted to operate any YWD valves.
- 1.2. Leakage Test – All work shall be performed by the YWD only. The Contractor shall coordinate with the YWD.
 - a. Leakage testing shall be conducted concurrently with the pressure test.
 - b. Leakage Defined. Leakage shall be defined as the quantity of water that must be pumped into the new main, or any valved section thereof, to maintain pressure within + 5 psi of the specified test pressure, after the main(s) have been filled with water and all air has been expelled. Leakage shall be recorded to the nearest one-tenth of a gallon, by means of a calibrated test meter. If allowed by the District, drawdown may be measured in a calibrated barrel. All records and charts shall become the property of the District. The Contractor shall employ qualified personnel throughout the testing. Leakage shall not be measured by a drop in pressure over a period of time.
 - c. Allowable Leakage. No pipe installation will be accepted if the leakage is greater than that determined by the following formula:

$$L = \frac{SD(P 0.5)}{133200}$$

where:

L = allowable gallons of leakage per hour

S = the length of pipe tested, in feet

D the nominal pipe diameter in inches

P the average test pressure during the test, in psi

The leakage formula is based on the allowable leakage of 11.65 gallons per day, per mile of pipe, per inch, (nominal) of pipe diameter, at a pressure of 150 psi. Allowable leakage values at various pressures, for various pipe diameters are shown below.

ALLOWABLE LEAKAGE PER 1000 FEET OF PIPELINE NOMINAL PIPE DIAMETER - (INCHES)

<i>Average Test Pressure psi</i>		6	8	10	12	16	20	24
250	0.71	0.95	1.19	1.42	1.90	2.37	2.85	
225	0.68	0.90	1.13	1.35	1.80	2.25	2.70	
200	0.64	0.85	1.06	1.28	1.70	2.12	2.55	
175	0.59	0.80	0.99	1.19	1.59	1.98	2.38	
150	0.55	0.74	0.92	1.10	1.47	1.84	2.21	
125	0.50	0.67	0.84	1.01	1.34	1.68	2.01	
100	0.45	0.60	0.75	0.90	1.20	1.50	1.80	

- d. If the pipeline under test contains sections of various diameters, the allowable leakage, will be the sum of the computed leakage for each size.
 - e. When testing against closed metal seated valves, an additional leakage shall be allowed per closed valve, of 0.0078 gallons per hour, per inch of nominal valve diameter.
 - f. When hydrants are in the test section, the test shall be made against the closed hydrant(s).
 - g. Acceptance shall be determined on the basis of allowable leakage. If any test of pipe discloses leakage greater than that specified, the Contractor shall locate and make approved repairs as necessary until the leakage is within the specified allowance.
 - h. All visible leaks are to be repaired regardless of the amount of leakage.
 - i. All water mains shall be pressure and leakage tested in the presence of the District, in order to qualify for acceptance.
 - j. The leakage test shall be performed for a minimum duration of two (2) hours.
- 1.3. Chlorination - The method of chlorination shall be the Continuous Feed Method as described hereinafter, and shall be completed by the YWD. The contractor shall coordinate with the YWD. The continuous feed method consists of the following steps:
- a. The Contractor and the District shall coordinate to identify acceptable location(s) for discharging the heavily chlorinated water, which will result from the chlorination procedures. Final acceptance of the water main(s) shall be based on successful (absence - negative) results of bacteria tests, which shall be done on samples taken from the main(s) following chlorination and final flushing. Locations of samples shall be as directed by the District.
 - A pumping unit or proportionate feeder suitable for delivering a hypochlorite solution to the isolated main shall be provided. The unit used shall prevent chlorine solution from flowing back into the existing system.
 - Chlorine solution for disinfecting water mains and appurtenances shall be made from either liquid sodium hypochlorite, or solid calcium hypochlorite, which shall conform, to the latest AWWA B300 Standard for Hypochlorite.
 - b. Fill the main(s) with chlorinated potable water, having an initial concentration of 25 mg/l free chlorine residual. After a 24-hour period, there shall be a minimum of 10 mg/l free chlorine residual in the main(s).
 - c. Water from the existing distribution system or other approved source of supply shall be made to flow at a constant measured rate, into the new main(s). In the absence of a meter, the rate may be approximated by

methods such as a pitot gauge in the discharge or measuring the time to fill a container of low volume.

- d. At a point not more than 10 feet downstream from main(s), water entering the new main shall receive a dose of hypochlorite solution fed at a constant rate such that the water in the main(s) will have not less than 25 mg/l free available chlorine. To assure that this concentration is achieved, the contractor shall measure chlorine concentration at regular intervals along the main(s), using appropriate chlorine test kits, or as otherwise described in the current edition of AWWA M12- Simplified Procedures for Water Examination.
- e. The amount of chlorine required to obtain a concentration of 25 mg/l per 100 feet of various diameter pipes is as follows.

CHLORINE REQUIRED TO OBTAIN A CONCENTRATION OF 25 PPM PER 100 FT. OF PIPE

Pipe Dia. (ins.)	SODIUM HYPOCHLORITE – GALLONS				CALCIUM HYPOCHLORITE
	5% Avail. Chlorine	10% Avail. Chlorine	12-1/2% Avail. Chlorine	15% Avail. Chlorine	65% Avail. Chlorine
4	0.03	0.02	0.02	0.01	0.32 Ounces
6	0.08	0.04	0.03	0.03	0.75 Ounces
8	0.13	0.07	1.06	0.06	1.30 Ounces
12	0.28	0.15	0.12	0.10	2.95 Ounces
16	0.50	0.25	0.22	0.17	5.30 Ounces

- f. The above quantities are to be added to a sufficient quantity of water, dissolved, and mixed. The entire solution shall be injected into the main as specified.
- g. The quantities shown are based on concentrations of available Chlorine by volume. Extended or improper storage may have caused a loss of available chlorine.
- h. For concentrations of 50 ppm, double the quantities listed.
- i. During the application of chlorine, valves shall be closed to prevent strong Chlorine solution in the new main(s) from flowing into the existing system. Chlorine application shall continue until the entire main(s) is filled with water having 25 mg/l of free available chlorine. The chlorinated water shall be retained in the main(s) for at least 24 hours, during which time all valves and hydrants in the section(s) being treated shall be operated, in order to disinfect the appurtenances. At the end of this 24 hour period, all portions of the main(s) and appurtenances being tested shall have a free available chlorine residual of at least 10 mg/l. If less than less 10 mg/l free available

chlorine is measured, the main shall be re-flushed and the entire disinfection process repeated.

- j. Hypochlorite solutions shall be applied to the water main(s) with a gasoline or electrically powered chemical feed pump designed for feeding chlorine solutions. Feed lines shall be of such material and strengths as to safely withstand corrosion caused by the concentrated chlorine solutions, and also the maximum pressures that may be created by the pumps. All connections shall be checked for tightness before the solution is applied to the main.
- 1.4. Final Flushing - After the specified retention period, the heavily chlorinated water shall be de-chlorinated by the YWD and flushed from the main until chlorine measurements show the concentration in water leaving the main is no higher than that generally prevailing in the system.
- a. Arrangements shall be made with the District to flush the mains of chlorinated water. Great care shall be exercised in the selection of the rate of flow and the discharge points, in order to minimize complaints, and damage to public or private property.
 - b. The environment to which the chlorinated water is to be discharged shall be inspected. If chlorinated discharge will cause damage to the environment, a solution of sodium thiosulfate shall be applied to the water that will thoroughly neutralize the chlorine residual. The contractor should make sure that such discharges meet all applicable state, federal, and local regulation for the disposal of heavily chlorinated water.
- 1.5. Bacteriological Tests shall be taken by the YWD
- a. Standard Conditions. After final flushing and before the water main is placed in service, water samples shall be collected twice (24-hours apart) at each sample point designated by the District and tested for bacteriological quality in accordance with Standard Methods. Water samples shall show the absence of coliform organisms and background bacteria. A standard plate count may be required at the option of the District. Water samples shall be taken at the locations directed by the District.
 - b. Special Conditions. If, during construction, trench water has entered the main, or if in the opinion of the District excessive quantities of dirt or debris have entered the main, bacteriological samples shall be taken at intervals of approximately 200 ft. and shall be identified as to the location.
 - c. Sampling Procedure. Samples for bacteriological analysis shall be collected by the District, in sterile bottles treated with sodium thiosulfate. No hose or fire hydrant shall be used in collection of samples. A corporation cock shall be installed in the main with a copper tube gooseneck assembly. After samples have been collected, the gooseneck assembly shall be removed by the contractor. The YWD shall sample twice (24 hours apart) at each location.
 - d. The YWD shall deliver samples to a laboratory approved by the Department of Human Services for bacterial analysis. The Contractor shall pay for the cost of analysis. Only after each consecutive sample is approved shall the

mains be incorporated into the water system. In the event, that positive reports of contamination are received, the mains shall be flushed as many times as may be necessary to obtain approved (absence/negative) results.

- 1.6. Re-Chlorination - If the initial chlorination fails to produce satisfactory bacteriological results the main(s) shall be reflashed and re-sampled. If check samples show the presence of coliform organisms, then the main shall be re-chlorinated by the continuous feed method of chlorination, until satisfactory results are obtained. High velocities in the existing system, resulting from flushing the new main, may disturb sediment that has accumulated in the existing mains. When check samples are taken, the Contractor shall sample water entering the new main.
- 1.7. **Chlorination Procedures When Cutting Into or Repairing Existing Mains** - The following procedures apply when mains are wholly or partially dewatered. After the appropriate procedures have been completed, the main maybe returned to service prior to completion of bacteriological testing, in order to minimize the time customers are out of water. Leaks or breaks that are repaired with clamping devices while the mains are full of water under pressure present little danger of contamination and require no disinfection.
 - a. Trench Treatment. When an old main is opened, either by accident or on purpose, the excavation will likely be wet and may be contaminated from nearby sources of sewage or other pollution. Liberal quantities of hypochlorite tablets shall be applied to open trench areas to lessen the danger from pollution.
 - b. Swabbing with Hypochlorite Solution. The interior of all pipe and fittings used in making a repair (particularly couplings and sleeves) shall be swabbed or sprayed with a 1 percent hypochlorite solution before they are installed.
 - c. Flushing. If valve and hydrant locations permit thorough flushing toward the work location from both directions, it shall be done. Flushing shall be started as soon as the repairs are completed and shall be continued until discolored water is eliminated.
 - d. Slug Chlorination. Where practical in addition to the procedures above, a section of main in which the break is located shall be isolated. All service connections shall be shut off, and the section flushed and chlorinated by the slug method and the dose may be increased to as much as 300 mg/I, and the contact time reduced to as little as 1-hour. After chlorination, flushing shall be resumed and continued until discolored water is eliminated and the water is free of noticeable chlorine odor.
 - e. Bacteriological samples shall be taken after repairs. If the direction of flow is unknown, samples shall be taken on each side of the main break. If positive samples are recorded, daily sampling shall be continued until two consecutive negative samples are recorded. Positive samples shall be evaluated by the Engineer for corrective action.

APPENDIX H

MDEP SITE LOCATION OF DEVELOPMENT ACT
GENERAL PERMIT

(This page left intentionally blank)



STATE OF MAINE
DEPARTMENT OF ENVIRONMENTAL PROTECTION



PAUL R. LEPAGE
GOVERNOR

PAUL MERCER
COMMISSIONER

February 2016

Maine Turnpike Authority
c/o Sara Zografos
2360 Congress St
Portland Maine 04102

RE: Site Location of Development Act General Permit, DEP #L-26825-TP-A-N

Dear Ms. Zografos:

Please find enclosed a signed copy of your Department of Environmental Protection General Permit. Please take several moments to read your permit carefully. The Department reviews every application thoroughly and strives to formulate reasonable conditions of approval within the context of the Department's environmental laws. You will also find attached some materials that describe the Department's appeal procedures for your information.

If you have any questions about the permit or thoughts on how the Department processed this application please get in touch with me directly. I can be reached at (207) 446-1611 or at mike.mullen@maine.gov.

Sincerely,

Mike Mullen
Bureau of Land Resources

pc: File

AUGUSTA
17 STATE HOUSE STATION
AUGUSTA, MAINE 04333-0017
(207) 287-7688 FAX: (207) 287-7826

BANGOR
106 HOGAN ROAD, SUITE 6
BANGOR, MAINE 04401
(207) 941-4570 FAX: (207) 941-4584

PORTLAND
312 CANCO ROAD
PORTLAND, MAINE 04103
(207) 822-6300 FAX: (207) 822-6303

PRESQUE ISLE
1235 CENTRAL DRIVE, SKYWAY PARK
PRESQUE ISLE, MAINE 04769
(207) 764-0477 FAX: (207) 760-3143



STATE OF MAINE

DEPARTMENT OF ENVIRONMENTAL PROTECTION

SITE LOCATION OF DEVELOPMENT ACT

**General Permit for the
Maine Turnpike Authority**

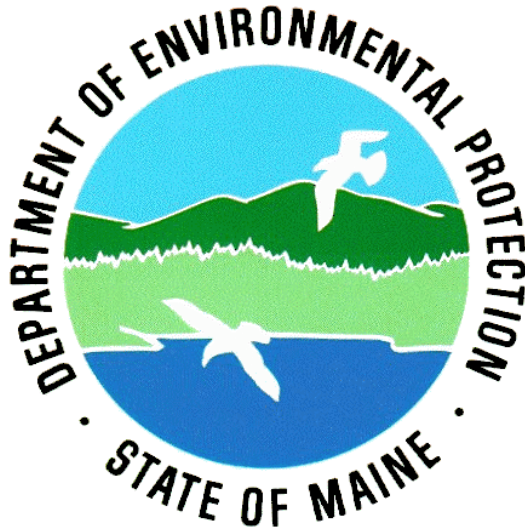

Bureau of Land Resources



I. General Permit Coverage

A. Basis: The Department of Environmental Protection (DEP) recognizes that the Maine Turnpike Authority (MTA) has established environmental procedures and standard practices that meet or exceed the requirements of the Site Location of Development Act (Site Law). MTA conducts environmental reviews of its proposed projects using professional staff and qualified consultants to ensure compliance with State and Federal environmental requirements and various initiatives including, but not limited to, the National Environmental Policy Act, Federal and State wetland permitting requirements, the Maine Department of Transportation's Best Management Practices for Erosion and Sediment Control (BMP's), the MaineDOT Waterway and Wildlife Crossing Policy and Design Guide, and the Memorandum of Agreement for Stormwater Management. MTA licensed engineering staff and consultants design projects in accordance with applicable standards including, but not limited to, the State of Maine Department of Transportation Standard Specifications for Highways and Bridges, and the American Association of State Highway and Transportation Officials (AASHTO) Design Standards. MTA has licensed engineers, land surveyors, planners, environmental compliance and legal staff, and supplements its internal staff through consulting contracts with several recognized engineering firms and an environmental compliance firm. MTA procedures and policies (as amended from time to time) relevant to meeting Site Law standards are listed below under sections specific to the standards.

B. Purpose: This General Permit for the Maine Turnpike Authority, hereinafter described as the MTA General Permit for Site Location of Development projects (GP), authorizes the MTA to construct or cause to be constructed or operate or cause to be operated all developments under MTA's authority for which approval is required pursuant to the Site Law, 38 M.R.S.A. §§ 481-490, after the approval by the DEP of a Notice of Intent as set forth in 38 M.R.S.A. § 486-B(3).

C. Authorization: This GP is authorized by 38 M.R.S.A. § 486-B. This permit does not affect requirements under other applicable Maine statutes such as the Natural Resources Protection Act, 38 M.R.S.A. § 480-A through 480-JJ (NRPA).

D. Effective period: This GP is effective February 29, 2016, and authorized through February 28, 2021. The DEP intends subsequent re-issuance of this GP. Performance and compliance under this GP will be assessed on an annual basis by MTA and DEP.

II. Standards

A development authorized by this GP is required to meet all applicable requirements of the Site Law pursuant to 38 M.R.S.A. § 484, the specific conditions listed in this section, and any conditions attached to an approval of a Notice of Intent.

A. Financial Capacity (38 M.R.S.A. § 484(1)): The MTA shall have the financial capacity and technical ability to develop a project in a manner consistent with state environmental standards and consistent with the Site Law. Funding commitments are authorized by the MTA's board through the MTA's Four Year Capital Investment Plan, Thirty Year Financial Plan, and annual Reserve Maintenance Deposit requirements.

Link to MTA Projects: <http://www.maineturnpike.com/getattachment/project-and-planning/Transportation-Planning/4-Year-Capital-Plan-12-18-2014.pdf.aspx>



B. No Adverse Effect on the Natural Environment (38 M.R.S.A. § 484(3)): In its construction and operation of the project, the MTA shall not adversely affect existing uses, scenic character, air quality, water quality or other natural resources in the municipality.

1. MTA staff and expert design consultants will review all projects for potential impacts to wetlands, vernal pools, streams, significant wildlife habitats, rare, threatened, and endangered species and unusual natural areas; coordinate with state and federal natural resource agencies; and incorporate agency recommendations as appropriate and practicable to minimize impacts to affected resources. When state and federal natural resource agencies and MTA cannot agree on recommendations to minimize impacts, MTA shall abide by DEP's requirements.
2. MTA will file NRPA permit applications with the DEP when appropriate or document exempt activities.
3. MTA will file applications with the U.S. Army Corps of Engineers (ACOE) in accordance with Section 404 of the Clean Water Act and Section 10 of the Rivers and Harbors Act.
4. MTA will design and construct all stream crossings in accordance with the *MaineDOT Waterway and Wildlife Crossing Policy and Design Guide for Aquatic Organism, Wildlife Habitat and Hydrologic Connectivity*, dated July 1, 2008. This document was developed by MaineDOT in cooperation with state and federal agencies; including DEP, Maine Department of Marine Resources (DMR), Maine Inland Fish & Wildlife (IF&W), National Marine Fisheries Service (NMFS), ACOE, United States Fish and Wildlife Service (USFWS), and Environmental Protection Agency (EPA).

Link to 2008 Waterway and Wildlife Crossing Policy and Design Guide:

http://digitalmaine.com/mdot_docs/59/

5. MTA will review projects for impacts to historic and cultural resources by consulting with the Maine State Historic Preservation Officer (SHPO) in compliance with the process that is described in Section 4 of the Programmatic Agreement between Federal Highway Administration (FHWA), Federal Transit Administration (FTA), the Advisory Council on Historic Preservation (ACHP), SHPO, and MaineDOT, dated November 2004. However, because the MTA does not normally receive federal funds, the MTA will consult with the federal agency, if any, that is responsible for permitting the MTA project at issue rather than with FHWA or FTA. In almost all cases, this agency would be the ACOE. In all cases, the results of the consultation will be subject to review and approval from DEP. This process will be utilized on all projects that trigger the Site Law.

Link to Section 106 Programmatic Agreement:

<http://www.maine.gov/mdot/env/docs/Section106ProgrammaticAgreement.pdf>

6. If the applicable MTA project is included in a MaineDOT Statewide Transportation Improvement Program (STIP) that has undergone an air quality analysis, the project "will not significantly affect the ambient air quality" for permitting purposes. If the applicable MTA project is not included in a MaineDOT STIP, the MTA will comply with Chapter 375, Section 1 of the DEP rules which may require, among other things, modeling of non-point sources of air pollution and the submittal of the results with the Notice of Intent for review by the DEP.

Link to MaineDOT Statewide Transportation Improvement Program:

<http://www.maine.gov/mdot/stip/>



7. MTA has adopted a statewide Noise Policy, effective January 2015, which is identical in all important respects to the FHWA-approved MaineDOT noise policy, and serves to guide decision-makers on all noise related matters associated with transportation. In addition, all projects will meet the noise standards of Chapter 375 §10 of the DEP Rules, as applicable.

Link to MTA Noise Policy:

<http://www.maineturnpike.com/getattachment/Business-With-MTA/Neighbors-Abutters/Noise-Policy/NoisePolicy2015Final.pdf.aspx>

8. MTA will hold public meetings on all proposed projects to allow public input, per Section II(I) of this GP. These meetings are an opportunity for the public to identify issues of local interest including areas with unique or scenic character.

Professional landscape architects will review site plans and design landscape plans as appropriate for the type of project, its surrounding area, and any identified scenic resource. The MTA has a licensed landscape architect on staff.

The MTA right-of-way department and planning staff will identify all public parks, recreation areas, public wildlife and waterfowl refuges, and land of significant historic properties associated with a transportation project and will avoid and minimize impacts to these categories of resources in consultation with DEP.

- C. **Soil Types (38 M.R.S.A. § 484(4)):** MTA developments shall be built on soil types that are suitable to the nature of the undertaking. MTA employs or contracts with geotechnical engineers that are part of the design team for all projects to evaluate the suitability of existing soils and determine the need for engineering practices to address soil limitations.

MTA employs or contracts with licensed site evaluators that design new or replacement septic systems in accordance with the Maine State Plumbing Code and the Maine Subsurface Wastewater Disposal Rules. These systems are reviewed and permitted by the Maine Department of Health and Human Services (DHHS) and/or the applicable municipality.

- D. **Storm Water Management and Erosion Control (38 M.R.S.A. § 484(4-A)):** MTA shall comply with the Storm Water Management and Erosion Control Standard of the Site Law through implementation of the requirements outlined below. The definitions included in the *Memorandum of Agreement for Stormwater Management between the Maine Department of Transportation, Maine Turnpike Authority, and the Maine Department of Environmental Protection*, effective November 2007, are incorporated in this GP.

Link to MaineDOT/MTA/DEP's MOA on Stormwater:

<http://www.maine.gov/mdot/env/docs/StormwaterMOA.pdf>

1. **Basic Standards:** MTA requires an Erosion Control Plan (developed by the contractor and approved by MTA) for all projects in accordance with the *Maine Department of Transportation's Best Management Practices for Erosion and Sediment Control (BMP's)*, dated February 2008. All projects meeting this GP shall comply with the Basic Standards of the DEP Stormwater Rules.



Link to MaineDOT's Best Management Practices for Erosion and Sediment Control:

<http://www.maine.gov/mdot/env/docs/bmp/BMP2008full.pdf>

2. General Standards: For projects that are large enough to trigger the General Standard threshold in the DEP's Chapter 500 Stormwater Management Rules, MTA shall meet the General Standards for all projects as follows:
 - a) A linear portion of a project associated with an existing travel corridor shall meet the General Standards to the extent practicable using existing available right of way as determined through consultation with, and agreement by, DEP.
 - b) A linear portion of a project that is not associated with an existing travel corridor shall meet the General Standards to the extent practicable as determined through consultation with, and agreement by, DEP.
 - c) A non-linear portion of a project shall meet the General Standards, except that redevelopment of existing impervious area may qualify for the exception in DEP's Chapter 500 § 4(C)(2)(d).
3. Phosphorus Standard. Projects triggering the Phosphorus Standard shall instead apply the General Standards in accordance with Section D(2) above of this GP.
4. Urban impaired stream standard. A linear or non-linear portion of a project that is not associated with an existing travel corridor, is located within the watershed of an urban impaired stream and triggers the Urban Impaired Stream Standard shall meet the Urban Impaired Stream Standard in Chapter 500 § 4(E) to the extent practicable as determined through consultation with, and agreement by, DEP. MTA may use mitigation credit measures within the same watershed as that portion of a project in order meet the requirements of Chapter 501 § 3(A) of the DEP Rules.
5. Flooding Standard. For a state transportation system project that triggers the thresholds of the Flooding Standard, MTA shall apply design and engineering measures to the extent practicable such that project drainage avoids adverse impacts to offsite property resulting from project-related peak flows.

E. Groundwater (38 M.R.S.A. § 484(5)): MTA shall construct and operate the development project in a manner that will not pose an unreasonable risk that a discharge to a significant groundwater aquifer will occur. MTA engineering staff and consultants will develop viable and sustainable water extraction practices for both potable and production systems. The MTA's Environmental Coordinator, in conjunction with its environmental consulting firm, has developed and continuously updates sound management practices for, and training in, the storage of hazardous materials. These actions are directed toward minimizing impacts to waters recharging the groundwater regime. In the event of a release of hazardous materials, contingencies are in place to undertake prompt response actions to minimize environmental harm.

MTA's Maintenance facilities comply with relevant sections of DEP's Spill Prevention, Control and Countermeasures (SPCC) Plan requirements as applicable. Facilities that exceed regulatory petroleum storage thresholds have site specific plans and perform required training and inspections. This initiative focusing on the proper management and response to releases and discharges is further supported by MTA's internal procedures related to spill prevention and response.



- F. Infrastructure (38 M.R.S.A. § 484(6)):** MTA developments shall make adequate provisions for utilities, including water supplies, sewerage facilities and solid waste disposal required for the development, and developments shall not have an unreasonable adverse effect on the existing or proposed utilities in the municipality or area served by those services.

In locations where a subsurface wastewater disposal facility may be constructed, it must be designed, installed and operated in accordance with relevant sections of Maine DHHS's subsurface disposal system regulations to ensure effluent emanating from the systems is readily attenuated thereby minimizing groundwater quality concerns.

The MTA's right-of-way department will identify all utilities within a project area and will be responsible for coordinating with municipal and private utilities to ensure no unreasonable burden on, disruption of, or interference with, service.

MTA's Environmental Coordinator reviews projects to ensure that all solid, special, universal, and hazardous wastes associated with transportation projects are managed in accordance with State and Federal Requirements.

- G. Flooding (38 M.R.S.A. § 484(7)):** MTA developments shall not unreasonably cause or increase the flooding of the alteration area or adjacent properties nor create an unreasonable flood hazard to any structure. MTA will design all projects to meet this criterion through consultation with DEP.

MTA will evaluate potential impacts of a proposed development to flood zones and adjacent properties and will design, construct and operate the development to avoid or mitigate such impacts. Presidential Executive Order 11988 applies to MTA projects requiring a federal permit.

Link to Presidential Executive Order 11988:

<http://www.archives.gov/federal-register/codification/executive-order/11988.html>

- H. Blasting (38 M.R.S.A. § 484(9)):** MTA shall conduct any blasting for developments in accordance with the standards in 38 M.R.S.A. § 490-Z (14). MTA Standard Specifications for contractors (Section 105.2.7) provides detailed requirements for blasting which meet or exceed the statutory requirements. These standard specifications require that the contractor submit a detailed blasting plan for approval prior to blasting, and require consultation with the MTA, State Police and owners of nearby utilities prior to blasting. MTA specifications require pre- and post-blast surveys of structures in the area, including pre-blast water quality tests of private wells. MTA specifications contain detailed safety procedures to be observed during blasting, require that a qualified vibration and blasting expert monitor all blasting and require that seismographic recordings are taken in the blast vicinity and supplied to MTA personnel within 2 days of every blast. MTA specifications incorporate by reference the Bureau of Mines ground vibrations limits contained in the Bureau of Mines Report #8507.

Link to MTA Standard Specifications for Blasting:

<http://www.mainturnpike.com/getattachment/project-and-planning/Construction-Contracts/Special-Provisions-Use-of-Explosives.pdf.aspx>

- I. Public Involvement:** MTA will treat every project under this GP as a "Substantial Public Interest Project" under its existing Public Participation Plan, effective May 2010, and will include at least one preliminary public meeting and one final public meeting on every project, depending on the scope of the



project and anticipated level of public interest. Project details must be presented at all public meetings. MTA will notify the public in accordance with Chapter 2, the DEP's Rule Concerning the Processing of Applications and Other Administrative Matters for all projects performed under this GP.

Link to MTA's Public Participation Plan:

<http://www.maineturnpike.com/getattachment/Construction-Info/Transportation-Planning/Public-Participation-Policy-Board-Approved-June-17-2010.pdf.aspx>

III. Submittals

- A. Notice of Intent Form:** The Notice of Intent (NOI) form shall be completely filled out and signed by the Executive Director of the MTA.
- B. Location Map:** A map showing the location and extent of the project shall be submitted. A U.S.G.S. topographic map or Maine Atlas and Gazetteer map are acceptable for this purpose.
- C. Plans:** MTA shall submit site plans of the proposed development with the NOI. Plans shall include, at a minimum, existing and proposed structures, permanent erosion and sedimentation measures, stormwater management structures, best management practices and buffers, clearing limits, and impervious areas. Other information may be required by the DEP as described in section 2(B)(6) above or on a case by case basis.

IV. Conditions of Approval

The DEP may attach reasonable conditions to the approval of the NOI to ensure compliance with standards under the Site Law in addition to the following conditions:

- A. Retention of Records:** MTA shall retain copies of all reports, certifications and approvals required by this GP, and records of all data used to complete the NOI of the project to be covered by this GP, for a period of at least three (3) years from the date the NOI is filed. The DEP may extend the time of record retention at any time.
- B. Accessibility:** MTA shall make a copy of the NOI and all supporting data available to the public.
- C. Inspection and Entry:** Employees and Agents of the DEP may enter any property that is the subject of the NOI at reasonable hours in order to determine compliance.
- D. Approval of Variations from Plans:** The granting of this approval is dependent upon and limited to the proposals and plans contained in the NOI and supporting documents submitted by the applicant. Any variation from these plans, proposals, and supporting documents is subject to review and approval prior to implementation.
- E. Transfer of Development:** In the event that the ownership of a project that is subject to this General Permit is transferred to a new owner, the MTA shall notify the DEP of a change in ownership. Subsequent development of the project by other parties is not covered under this GP.
- F. Time frame for approvals:** If the construction or operation of the project is not begun within four years, this approval shall lapse and the MTA must submit a new NOI to the DEP for approval. The MTA may not begin construction or operation of the development until a new NOI is approved. A new NOI may



include information submitted in the initial NOI by reference. This approval, if construction is begun within the four-year time frame, is valid for seven years. If construction is not completed within the seven-year time frame, the MTA must submit a new NOI, and receive approval prior to continuing construction.

V. Review

The DEP will approve a proposed MTA development upon receipt and review of a completed NOI, acceptable for processing, for a project determined to be in compliance with the standards of this GP. The DEP reserves the right to require additional documentation or adjustments to procedure to ensure that all requirements of this GP will be met.

VI. Procedure

A. Notice of Intent: An NOI must be submitted by MTA for a proposed development with submittals as described in Section III above. By submitting the NOI MTA agrees to comply with the terms and conditions of this GP.

B. NOI Submission: MTA shall file the NOI on a form provided by the DEP. The NOI shall contain all information required in this GP and the NOI form.

C. Deficient NOI: If any portion of the NOI does not meet one or more of the minimum requirements, or if the DEP requests additional information to ensure compliance with standards of the Site Law, the applicant will be notified of the deficiency within fourteen (14) calendar days. It is the responsibility of the MTA to make all required changes and resubmit the NOI or submit the required additional information. A new review period will begin when the revised NOI or supplemental information is received by the DEP.

D. Processing the NOI: Prior to the authorization of a development pursuant to this GP, an NOI must be reviewed and approved by the DEP within thirty (30) calendar days of receipt unless the DEP approves or denies the NOI prior to that date. If MTA does not receive correspondence from the DEP within the thirty (30) calendar day period after the submission of an NOI, then MTA is authorized to carry out the activity. If an NRPA permit is required for any portion of the development, the NOI and the NRPA application shall be submitted together. Excepting those situations where only a Permit by Rule Notification is required to satisfy an NRPA permitting requirement, the NOI review period will run concurrently with the NRPA permit review period and the length of the NOI review period will be the same as the review period for the NRPA permit application.

E. Individual Permit: Pursuant to 38 M.R.S. §486-B(4), the DEP may require the MTA to apply for an individual permit for a development that would otherwise be authorized to file an NOI under this General Permit. The DEP may require an individual permit application to be filed when it determines that a proposed development warrants a more extensive analysis under the Site Law licensing criteria, 38 M.R.S. §484, than that provided in the General Permit process. If an individual permit is required under this subsection and 38 M.R.S. §486-B(4), the DEP will notify the MTA within 30 days of receipt of a complete NOI. When the DEP notifies the MTA that an individual permit is required, no construction may occur unless and until an individual permit is issued.

F. Where to Submit: A completed and signed NOI must be submitted to:



**Director
Land Division
Bureau of Land Resources
Maine Department of Environmental Protection
17 State House Station
Augusta, Maine 04333-0017**

VII. Approval

An MTA development is considered to be authorized under this GP upon approval of an NOI in accordance with Section VI of this GP.

VIII. Fee

The DEP will not charge a fee for processing and approval of an NOI under this GP in accordance with 38 M.R.S.A. § 486-B (6).

IX. Modification of General Permit and NOI

The DEP may modify this GP and/or the NOI at any time with notification to the MTA.

X. Right to Appeal

All final license or permit decisions made by the Commissioner may be appealed to the Board of Environmental Protection pursuant to 38 M.R.S.A. § 341-D (4).

DONE AND DATED AT AUGUSTA, MAINE, THIS 29TH DAY OF FEBRUARY, 2016.

DEPARTMENT OF ENVIRONMENTAL PROTECTION

BY: 
For: Paul Mercer, Commissioner

PLEASE NOTE ATTACHED SHEET FOR GUIDANCE ON APPEAL PROCEDURES

MM/L26824AN/ATS#80071

Date of Public Notice: January 11, 2016

Date filed with Board of Environmental Protection: February 29, 2016

This Order prepared by Michael K. Mullen, BUREAU OF LAND RESOURCES

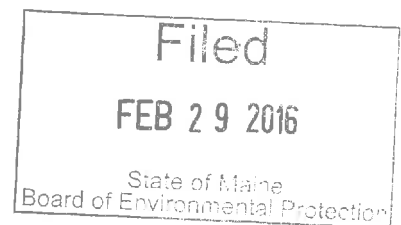

APPENDIX I

MDEP SITE LOCATION OF DEVELOPMENT
ACT AND NATURAL RESOURCES
PROTECTION ACT

(This page left intentionally blank)



DEPARTMENT ORDER

IN THE MATTER OF

MAINE TURNPIKE AUTHORITY) SITE LOCATION OF DEVELOPMENT ACT
York, York County) GENERAL PERMIT
YORK TOLL PLAZA) NATURAL RESOURCES PROTECTION ACT
) FRESHWATER WETLAND ALTERATION
L-27241-TG-A-N (approval)) WATER QUALITY CERTIFICATION
L-27241-TP-B-N (approval)) FINDINGS OF FACT AND ORDER

Pursuant to the provisions of 38 M.R.S. §§ 481–489-E and §§ 480-A–480-JJ, Section 401 of the Federal Water Pollution Control Act (33 U.S.C. § 1341), and Chapters 310, 315, 335, 375, and 500 of Department rules, the Department of Environmental Protection has considered the application of the MAINE TURNPIKE AUTHORITY with the supportive data, the public hearing testimony, agency review comments, the written comments submitted by the general public, and other related materials on file and FINDS THE FOLLOWING FACTS:

1. PROJECT DESCRIPTION AND PROCEDURAL HISTORY:

A. Project Description: The Maine Turnpike Authority (MTA or applicant) is seeking Department approval for the construction of a new barrier toll plaza at Mile 8.8 of the Maine Turnpike that will include six open, E-ZPass lanes (three northbound and three southbound) with overhead open framed gantries with electronic toll collection equipment, called Open Road Tolling (ORT). In addition to the highway speed electronic tolling lanes, the toll plaza will include nine lanes with toll booths designed for cash collection (four northbound and five southbound); a 2,400-square foot administration building on the west side of the Turnpike; a service tunnel running underneath the Turnpike for the safe passage of staff from the administration building to the toll booths and for the storage of toll equipment and utilities; an access drive from Chase’s Pond Road to the administration building on land owned by the applicant; expansion of the existing Turnpike mainline for approach and departure lanes; construction of stormwater treatment units; the demolition of the existing barrier toll plaza and administration building at Mile 7.3; and the reduction in the pavement at the existing toll plaza.

The proposed project will disturb approximately 58 acres and will include the redevelopment of approximately 38.5 acres of existing impervious area and the creation of approximately 15 acres of new impervious area. The proposed project will extend from Mile 7.0 to Mile 9.5. The existing toll plaza (toll booths and administration building) will be removed and a portion of the existing pavement will be reconfigured from a 17-lane toll plaza to a six-lane throughway. At Mile 8.8 the new toll plaza will result in the alteration of approximately 7,200 linear feet of highway within the right-of-

way of the existing travel corridor to accommodate lane widening and the toll collection infrastructure. Development of the new administration building, with its associated parking and the access drive, will occur on a 32.6-acre parcel of land owned by the applicant that abuts the right-of-way of the travel corridor to the west of the project site.

The proposed project will alter approximately 24 linear feet of stream, approximately 63,659 square feet (1.46 acres) of freshwater wetlands, including alteration of wetlands located within the 250-foot, critical terrestrial habitat surrounding significant vernal pools, and wetlands associated with habitat for rare, threatened, and endangered species. The proposed project will also alter 62,195 square feet (1.43 acres) of upland within the critical terrestrial habitat of significant vernal pools.

The proposed project is shown a set of plans, the first of which is titled “York Toll Plaza, General Plan 1”, prepared by Jacobs Engineering Group, Inc. and Sebago Technics, Inc. and dated August, 2016, with a last revision date on any of the sheets of April 3, 2017.

B. Current Use of the Site: The highway and toll collection portion of the project site will be located within the right-of-way of the Interstate I-95 travel corridor in which a six-lane divided highway is currently located. The adjacent 32.6-acre parcel, through which the access road from Chase’s Pond Road to the administration building will be constructed, is currently undeveloped woodlands and forested wetlands.

C. Procedural History: On October 19, 2016, the MTA filed an application with the Department of Environmental Protection (Department) for a Natural Resources Protection Act (NRPA) Permit for the construction of a barrier toll plaza at Mile 8.8 on the Maine Turnpike (Turnpike) which is part of Interstate I-95 in the Town of York.

The applicant also submitted a Notice of Intent (NOI #81265) to comply with the standards and requirements of the Site Location of Development Act (Site Law) General Permit (General Permit) for the Maine Turnpike Authority (DEP #L-26825-TP-A-N, effective February 29, 2016). The General Permit authorizes the applicant to construct all developments under the applicant’s authority for which approval is required pursuant to the Site Location of Development Act, 38 M.R.S. §§ 481-490, after the Department’s approval of the NOI. Section VI(D) of the General Permit stipulates that when an NRPA permit is required for a project, the NOI review period will run concurrently with the NRPA permit application review period and the length of the review period will be the same as the review period for the NRPA permit application.

Several interested persons, including the Town of York and a citizens’ group, Think Again, requested that the Department conduct a public hearing. Based upon the information submitted by the interested persons and pursuant to the Department’s Chapter 2 *Rules Concerning the Processing of Applications and Other Administrative Matters*, Sections 7(B) and 17(C), the Department determined, and conveyed in a letter dated December 2, 2016, that it would not recommend that the Board of Environmental Protection (Board) assume jurisdiction over the processing of the application, but that the Department would hold a public hearing on the proposed project.

On January 30, 2017, the Department received a Petition to Intervene from the Town of York and from the citizens' group, Think Again. Both petitions were granted on February 14, 2017 and the two intervenors consented to being consolidated into one.

During the Department's public hearing process, the Department's Presiding Officer issued four procedural orders:

1. The First Procedural Order, dated February 14, 2017, granted intervenor status to the Town of York and Think Again and consolidated the two intervenors into one called Citizens for Responsible Toll Collection (CRTC, or the Intervenors).
2. The Second Procedural Order, dated March 14, 2017, set a date for the public hearing and established procedures for pre-filed testimony.
3. The Third Procedural Order, dated May 12, 2017, ruled on the applicant's objection to certain witnesses testifying at the public hearing and established a public hearing schedule. This Order also acknowledged CRTC's request that the Presiding Officer ask the applicant to submit an updated version of the model prepared by its consultant, CDM Smith. The request was not acted upon in the Order, and the Department's decision was deferred on this matter until after the public hearing.
4. At the public hearing, CRTC renewed its request that the Presiding Officer ask the applicant for an updated model that calculates the necessary surcharge for an all-electronic tolling (AET) facility to maintain net revenue neutrality with an ORT facility over the initial ten-year period between 2020 and 2029. The Intervenors asserted that, because construction of an ORT toll plaza would not be completed until 2020, the model inputs should be revised to reflect predicted conditions for that period. The applicant responded that running the 2014 model with a seven-year delay would create unreliable predictions that could not be used in the decision-making process utilized by the MTA Board. The Presiding Officer allowed the two parties to file post hearing briefs on the request. The Fourth Procedural Order, dated June 16, 2017, ruled that the Department would not request submission of an updated model by the applicant.

The public hearing on the application was held on May 22, 2017 at the Kittery Community Center's Star Theater in the Town of Kittery. A portion of the public hearing was devoted to receiving testimony from members of the general public. Written comments were accepted throughout the application processing period, until the close of the hearing on May 22, 2017.

The Department released a Draft Order on September 5, 2017 for public comment. The Draft Order was sent to all of the interested parties and a copy was also placed on the Department's website. The comment period on the Draft Order closed on September 12, 2017. The Department received comments from the applicant and the Intervenors. All

the comments were reviewed and given consideration in relation to the statutory review criteria.

2. EXISTING SCENIC, AESTHETIC, RECREATIONAL OR NAVIGATIONAL USES:

The NRPA, in 38 M.R.S. §480-D (1), requires the applicant to demonstrate that the proposed project will not unreasonably interfere with existing scenic, aesthetic, recreational and navigational uses.

To demonstrate that its proposed project meets this criterion, the applicant submitted a description of the uses of the site, which include a multi-lane highway, tolling structures, and associated facilities. The applicant also submitted several photographs of the proposed project site and surroundings, including an aerial photograph of the project site. In accordance with Chapter 315, *Assessing and Mitigating Impacts to Scenic and Aesthetic Uses* (06-096 C.M.R. ch. 315, effective June 29, 2003), the applicant submitted a copy of the Department's Visual Evaluation Field Survey Checklist as Appendix A with the application. Department staff visited the project site on August 28, 2015, December 17, 2015, and April 5, 2017.

The proposed project is not located in a scenic resource visited by the general public, for the use, observation, enjoyment and appreciation of its natural and cultural visual qualities. The proposed project is adjacent to a scenic resource, the Whippoorwill Conservation Area. This area is an approximately 180-acre open space associated with the Whippoorwill Subdivision and subject to a conservation easement held by the York Land Trust. The easement limits public access to primarily the residents of the Whippoorwill Subdivision and the Grantor of the easement, and states that the general public will not be excluded unless such use becomes obtrusive or destructive. In written comments from interested persons and from testimony at the hearing, it was established that the conservation area is frequently used for recreational pursuits such as walking and bird-watching. The established trails within the conservation area are approximately 600 to 700 feet east of the Turnpike near the proposed location of the northbound toll booths. Because of land topography and forest cover between the project site and the scenic resource, the proposed project site is not visible from the currently established trails on the open space conservation parcel.

In response to questions from the general public, the applicant proposes to limit the effects from illuminating the new toll plaza by utilizing LED, fully cut-off lighting. Cut-off lights are designed such that no light is emitted above the horizon. The applicant also proposes to use lights that will emit light in the warmer (yellow) side of the spectrum as opposed to the blue hues typically associated with LED lights. To further minimize lighting impacts, the applicant proposes to place house-side light shields to control light intensities leaving the project site. Final lighting designs are being prepared. Prior to the start of construction, the applicant must submit a final photometric plan for the proposed project to the Department for review.

The Department staff utilized the Department's Visual Impact Assessment Matrix in the evaluation of the proposed project, and the Matrix showed an acceptable potential visual impact rating for the proposed project. Based on the information submitted in the application, the distance from the scenic resource, the visual impact rating, and the site visits, the Department determined that the location and scale of the proposed activity is compatible with the existing visual quality and landscape characteristics found within the viewshed of the scenic resource in the project area.

In its determination of the proposed project's potential impacts to existing scenic, aesthetic, and recreational uses, the Department considered the significance of the Whippoorwill Conservation Area, the existing character of the surrounding area, the distance between this scenic resource and the project site, and the expectations of the typical user. The Department also considered the significance and public purpose of the proposed project and the applicant's actions to mitigate for impacts from overhead lighting. Based on the information submitted in the application, the visual impact rating, the site visits, and for the reasons stated above, the Department finds that the location and scale of the proposed activity is compatible with the existing visual quality, recreational uses, and the landscape characteristics found adjacent to the scenic resource.

The application included the MTA Noise Policy and a noise study of the project area. The MTA Noise Policy stated that highway noise is generated from four major sources: vehicle engines, vehicle exhaust, aerodynamics, and tire-to-pavement friction; with tire noise being the dominant source from vehicles travelling at speeds greater than 20 miles per hour. The MTA Noise Policy also stated that the level of highway noise is dependent on the volume of free-flow traffic, the speed of that traffic, and the number of trucks in the flow of traffic. The MTA Noise Policy noted that geographic factors, such as steep inclines affect noise levels. The applicant's report titled "Noise Analysis Report," prepared by Jacobs Engineering Group, Inc. and dated September 27, 2016, documented potential noise impacts associated with the proposed project. Estimated vehicle noise emissions were calculated for different periods of time and considered the build/no-build alternatives using the Federal Highway Administration's Traffic Noise Model. The model was calibrated using seven sites within the project area, including the Whippoorwill Subdivision. The model results predicted that noise levels resulting from the proposed project would result in a one decibel increase in noise over the no-build scenario, which is considered to be equivalent to existing conditions. The report highlighted that moving the toll plaza from its current location will eliminate the need to accelerate up the northbound hill and hard braking down the same hill when traveling southbound, which would reduce current noise levels. Regarding construction noise, the MTA Noise Policy stated that during the design phase of transportation projects, the applicant will work with local public officials and the local community to limit and minimize adverse construction noise, as practicable. Based on the information provided by the applicant, the Department finds that noise resulting from the proposed project is compatible with existing conditions.

The applicant's report titled "Air Quality Report," prepared by Jacobs Engineering Group, Inc. and dated September 1, 2016, compared the results of air modeling that

examined total pollutant burdens from the proposed project and existing conditions. Modeling results predict an improvement in ambient air quality at the existing toll plaza location. Although the model predicted that the new toll plaza location would have a minor reduction in ambient air quality, the improvements in traffic moving through at highway speeds would reduce traffic congestion. Correspondingly, the reduced congestion will result in less brake and tire wear, which contribute to particulate matter and emissions of volatile organic compounds, carbon monoxide, and nitrous oxide. Based on the information provided by the applicant, the Department finds that changes to air quality resulting from the proposed project is compatible with existing conditions.

There are no navigational uses of any resources that would be unreasonably impacted by the proposed project.

The Department finds that the proposed activity will not unreasonably interfere with existing scenic, aesthetic, recreational or navigational uses of the protected natural resource provided that prior to the start of construction, a final photometric plan for the proposed project is submitted to the Department for review.

3. SOIL EROSION:

The NRPA, in 38 M.R.S. §480-D(2), requires the applicant to demonstrate that the proposed project will not cause unreasonable erosion of soil or sediment nor unreasonably inhibit the natural transfer of soil from the terrestrial to the marine or freshwater environment.

Included on the set of plans referenced in Finding 1 were the proposed location of silt fence intended to capture sediment mobilized in stormwater runoff.

To meet the terms of the Site Law General Permit, the applicant is required to develop an erosion control plan for the proposed project that conforms with the *Maine Department of Transportation's Best Management Practices for Erosion and Sediment Control (BMP's)*, dated February 2008. To comply with the requirements of the General Permit, the contractor for the proposed project will be required to submit an erosion control plan to the applicant prior to the start of construction for approval by the applicant. This plan will provide specifications for the installation and implementation of soil erosion and sedimentation control measures based on site-specific conditions, the construction sequence, timing, and weather.

Prior to the start of construction, the applicant must submit an erosion control plan for the proposed project to the Department for review and approval.

The Department finds that the activity will not cause unreasonable erosion of soil or sediment nor unreasonably inhibit the natural transfer of soil from the terrestrial to the marine or freshwater environment provided that the erosion control plan is submitted to the Department for review and approval prior to the start of construction.

4. WETLANDS AND HABITAT:

The NRPA, in 38 M.R.S. §480-D(3), requires the applicant to demonstrate that the proposed project will not unreasonably harm significant wildlife habitat, freshwater wetland plant habitat, threatened or endangered plant habitat, aquatic or adjacent upland habitat, travel corridor, freshwater, estuarine or marine fisheries or other aquatic life.

The applicant proposes to directly alter approximately 24 linear feet of stream, approximately 63,659 square feet (1.46 acres) of freshwater wetlands, including alteration of wetlands located within the critical terrestrial habitat of significant vernal pools, and wetlands associated with habitat for rare, threatened, and endangered species. The proposed project will also result in the alteration of 62,195 square feet (1.43 acres) of upland within the critical terrestrial habitat of significant vernal pools. The NRPA-regulated streams on the project site that are proposed to be altered are waterbodies that connect wetlands and either cross under the Turnpike through culverts or run adjacent to the highway in roadside ditches. The freshwater wetlands comprise a drainage network collecting water from the upland adjacent to the Turnpike and directing it into the Cape Neddick River, Whipoorwill Swamp, or Little River watersheds.

A. Wetlands

The *Wetlands and Waterbodies Protection Rules*, 06-096 C.M.R. ch. 310, interpret and elaborate on the NRPA criteria for obtaining a permit. The rules guide the Department in its determination of whether a project's impacts would be unreasonable. A proposed project would generally be considered to result in an unreasonable impact if it would cause a loss in wetland area, functions and values and there is a practicable alternative to the project that would be less damaging to the environment; however, the extent and severity of impacts to the wetlands and the value and functions of the wetlands impacted are weighed against the practicability of a potential, less damaging, alternative to the proposed project. The balancing of these factors underlies the Department's analysis of whether the impacts from the project as proposed are found to be unreasonable.

Each application for a NRPA permit that involves a freshwater wetland alteration must provide an analysis of alternatives. An applicant's analysis of whether there is a practicable alternative to the project that would be less damaging to the environment is considered by the Department in its assessment of the reasonableness of any impacts. Chapter 310 defines practicable as available and feasible considering cost, existing technology, and logistics based on the overall purpose of the project. In determining whether a practicable alternative exists, the applicant must consider using, managing, or expanding other locations that would avoid impacts to protected natural resources; reducing the size, scope, configuration, or density of the proposed project, and thereby avoiding or reducing impacts; and developing alternative project designs to further avoid or reduce impacts.

The applicant's stated project purpose is to replace the existing barrier toll plaza at Mile 7.3 of the Turnpike with highway-speed electronic tolling lanes (ORT) and cash

collection lanes that will address safety deficiencies at the existing plaza. The applicant states that ground settling and subsidence are occurring at the current toll plaza and facility deficiencies include substandard tolling equipment. The applicant states that its goal is to have the ability to adequately handle current and projected traffic volumes, and the ability to limit impacts to motorists while meeting expectations.

The Department finds that the applicant's description of its project purpose cannot be so narrow as to eliminate consideration of potential practicable alternatives. Thus, the Intervenor's evidence regarding a potential alternative which would be less environmentally damaging to the environment, in the form of an AET installation, was considered by the Department. The applicant also submitted evidence on this alternative.

1) Analysis of Avoidance: Alternative Tolling Methods

a) Applicant's Toll System Alternatives Analysis and Evidence.

The applicant submitted an alternatives analysis for the proposed project completed by Sebage Technics, Inc. and dated October 17, 2016. The applicant considered two methods of toll collection that provide highway-speed electronic tolling: open road tolling (ORT) and all-electronic tolling (AET). The ORT method includes both highway-speed tolling lanes for vehicles with an electronic toll collection device as well as conventional toll booths, similar to that which currently exists for cash toll collection, while the AET method is comprised of only highway-speed electronic tolling and eliminates roadside cash collection. The AET method uses cameras mounted on overhead gantries that record all vehicle license plates and records passing vehicles using electronic toll collection devices. For users that otherwise would pay a cash toll, AET utilizes a pay-by-mail system to identify license plate images, match license plates with addresses, prepare and mail invoices, and track payments. For both tolling methods, users that have an electronic toll collection device in their vehicle are assessed a toll which is then charged against the balance of their account.

The applicant commissioned two studies to evaluate the practicability of each tolling method. The results of the first study were published in a report titled "Maine Turnpike, Southern Toll Plaza, Initial All-Electronic Tolling Feasibility Review," prepared by HNTB and dated February 20, 2009. The HNTB report stated that the benefits that could be realized with an AET plaza included a significantly reduced physical presence, reduced capital construction costs, reduced operational and maintenance costs of the infrastructure, reduced traffic congestion, improved safety at the toll plaza, elimination of fare collection staffing and support, and reduced environmental impacts resulting from traffic moving through the toll plaza without having to slow or stop. The HNTB report also identified negative impacts such as increased costs for back office and customer service center operations; logistical difficulties such as weather impacts on the reliability of equipment to read license plates and retrofitting the other toll plazas to integrate into the AET system; significant revenue loss because of non-payment transactions resulting from patrons

choosing to simply not pay the invoice, improperly read license plates, and limitations of interstate agencies for providing vehicle-user data; and cost shifting onto patrons enrolled in electronic toll collection regimes resulting from non-payments from users that previously paid cash. The report concluded that there would be theoretical benefits to converting to an AET system, but noted that there would also be significant uncertainty related to the business costs. Based on the conclusion that revenue loss from an AET system poses a threat to the applicant and the lack of comparable industry information at the time of the report, converting to an AET system was not recommended by HNTB, the author of the report.

The results of the second study were published in a report, titled “Maine Turnpike ORT/AET Impact Analysis,” prepared by CDM Smith and dated April 14, 2014. The purpose of the CDM Smith report was to compare traffic, toll rates, operating costs and net revenue of an AET system over a 10-year forecast period to a continuation of the current cash collection of tolls. The applicant considers an ORT system to be equivalent to the current system because the only difference between the two is that motorists with electronic toll collection devices can move through an ORT toll plaza at highway speeds while the current system requires that they slow to pass through the toll gates. Impacts from installation of an AET system to net revenue were determined by estimating impacts to toll collection and operating costs, and potential revenue from administrative fees associated with non-payments. Because of uncertainties associated with an AET system that would no longer collect cash at the toll plaza, the CDM Smith report included a risk analysis of this tolling method that involved testing a range of assumptions regarding customer payments, image recognition, and other factors.

The CDM Smith report examined the predicted redistribution of traffic that currently utilizes cash payments. A portion of this traffic would be expected to convert to using the current electronic toll collection devices, another portion was estimated to divert from the Turnpike and use alternative routes, and the majority of motorists would have their license plate information captured by video with toll charges collected by a pay-by-mail system (video toll). The transactions of the video toll users were then subdivided into four basic groups: those transactions that would pay the toll; those transactions that would go unpaid; those transactions that were unbillable (i.e., vehicle owner addresses were not available); and, those transactions that resulted in unreadable license plates. The report predicted that 42% of all current cash collections would be lost following conversion to the AET method.

The CDM Smith report included a multi-variable model that was created to allow a comparison of the two tolling methods. ORT revenue generation was considered to be essentially the same as the current tolling method, so the ORT method was treated as the base case net revenue forecast. Based on this comparison, it was determined that a toll surcharge would be necessary to offset revenue loss predicted using an AET system. Surcharge rates ranging from zero to \$4.00, using \$1.00 intervals, were examined. For the first three years, net toll revenues from all of the AET options were less than the (ORT) base case; however, the model predicts that AET-based net

revenues with surcharges of \$3.00 and \$4.00 would rise above the base case after three years, while the AET-based net revenue with a \$2.00 surcharge would rise above the base case after five years. After considering both operating and capital investment cost, the CDM Smith report concluded that the best 10-year net total revenue would come from an AET system; however, the CDM Smith report states that for this to be achieved, a significant increase in charges, as much as \$3.00, would have to be assessed on vehicles that do not have electronic toll collection devices. As a result of the surcharge, the report predicts, there would be a significant increase in the number of traffic diversions off the Turnpike, and the report states that the additional traffic would create a negative impact on local area roads. Notwithstanding the net total 10-year revenue figures, given the financial risk discussed below, the CDM Smith report concluded that the selection of an ORT plaza at York would be the more prudent business decision.

The application included an April 30, 2014 MTA Staff Report on the status of tolling on the Turnpike at that time that documented the efforts the applicant had taken to improve management of the Turnpike, evaluated the information provided in the 2014 CDM Smith Report, and discussed MTA policy issues associated with converting to an AET system. These policy issues included fairness and equity for toll payers, traffic diversion from the Turnpike, customer service, safety, landowner impacts, environmental impacts, consistency with existing toll plazas, privacy, staffing and operations, financial responsibilities, and operational flexibility. The MTA Staff Report acknowledged that implementation of an AET system would involve lower capital costs, minimal environmental impacts, and enhanced safety. The detriments to AET implementation listed in the MTA Staff Report included higher operating costs associated with back office collection operations, loss of revenue from uncollectable tolls, the need to place a significant surcharge on pay-by-mail customers and with that, fairness issues (that one group is paying a disproportionate share over other groups), financial obligations related to current bonds and future borrowing, traffic diversions, and operational conflicts with the current tolling method at other toll plazas.

The applicant evaluated the findings of each of the three reports and concluded at its July 24, 2014 Board meeting that an AET system would not be a practicable alternative that meets the project purpose because of the estimated doubling of the current toll rate at the York Plaza for pay-by-mail customers; the projected loss of revenue resulting in the first years of initiation of an AET tolling method, regardless of the additional surcharge and from uncollectable transactions, estimated to be as high as 42%; the loss of confidence from bondholders and current lenders which would result in lower bond ratings and higher future borrowing costs; overall customer dissatisfaction for fare increases and changes to the point of service (change from pay cash at the toll plaza to a pay-by-mail system); the risk of significant traffic impacts on local roads resulting from the projected diversions off the Turnpike by motorists seeking to avoid the toll; the need to replace existing ORT toll plazas to implement an AET system over the entire Turnpike system; and the negative reaction of other toll agencies, bond rating firms, and bond investors to the precedent that a

permitting decision by an environmental agency would decide the toll collection methodology for the MTA.

The applicant further addressed the cost and financial impacts of implementing an AET system in a draft report submitted from the applicant's Chief Financial Officer, dated August 24, 2016. This report stated that the applicant has independent bonding capacity and that it receives no state funding, although it is subject to legislative review. The ability of the applicant to assure revenue is essential because in issuing its own bonds, the only collateral is the revenue stream. Bondholders are protected by means of bond resolutions, some of which include pledges that all revenues and cash are applied to the payment of the principal and interest to the bondholders; that the applicant may only use revenues in accordance with the terms of the bonds and may not impair the bondholders' rights; that with narrow exceptions, no free vehicular passage will be permitted and that no cost shifting favoring one group of users over another is permissible; and that specific steps for changing toll rates, schedules, classifications, and methodologies have been established and that the applicant must have a traffic consultant prepare a report showing that toll changes will meet the net revenue requirement in the fiscal year of the requested toll change and in the subsequent five years. The Chief Financial Officer's draft report stated that because all revenue is pledged and the applicant cannot accept annual losses, the applicant determined that projected revenue losses resulting from conversion to an AET system, as shown in the CDM Smith report, would require an extensive traffic and revenue analysis across the entire Turnpike. In addition, the Chief Financial Officer stated that an AET system carries an inherently higher risk which could result in a downgrade of the ratings on current or future bonds, which would increase borrowing costs, which would have to be covered by toll increases. This report supports the conclusion in the CDM Smith report that the selection of an ORT plaza at York would be the more prudent business decision.

b) Intervenors' Toll System Analysis and Evidence.

Beginning in 2008, the Town and the people that constitute the CRTC have been involved with the applicant's efforts to replace the existing toll plaza by requesting and participating in public meetings, and by providing input on the reports commissioned by the applicant.

The Town of York commissioned the eTrans Group to review the HNTB and CDM Smith reports. The eTrans Group produced a report titled, "Shortfalls in MTA's Response to the Army Corps of Engineers," dated March 30, 2016. The report listed a number of items not addressed by the applicant in its September 1, 2015 correspondence to the Corps as part of the Phase I Avoidance assessment for the Corps licensing process. It stated the acknowledged environmental and safety benefits of constructing an AET system and offered a possible location on the Turnpike for placement of AET gantries. The eTrans Group report also described shortfalls in the applicant's financial analyses, specifically, that the CDM Smith report focused only on what the eTrans Group considered worst-case conditions, that

the CDM Smith report only examined impacts of converting only two of the 18 toll collection locations on the Turnpike, and that the CDM Smith report only considered a ten-year study period. The eTrans Group report asserted, in part, that estimates of the more significant benefits of converting to an AET system were not considered, that the assumed surcharge fees were inconsistent with industry practices, that capital cost estimates will continue to rise over time, and that the traffic diversion projections were overestimated.

In a letter dated June 16, 2016, the Town of York argued that the applicant's decision to reject AET as the most practicable tolling method to meet the project purpose is not supported by the CDM Smith report. The Town of York reiterated the previously identified benefits to implementing an AET system versus an ORT system but acknowledged that, in doing so, additional costs from video toll transactions would be required and that there would be some loss of revenue from uncollectable toll transactions. The letter highlighted those portions of the CDM Smith report that predict that the AET system will generate more revenue over time, and questioned the applicant's assertion that a \$3.00 surcharge would be inappropriate or problematic.

c) Public Hearing.

The testimony at the May 22, 2017 public hearing was focused on those issues related to the licensing criteria relevant to the NRPA permit application filed by the applicant, for the most part the issue of the alternatives analysis.

The pre-filed testimony from the applicant described the process by which the MTA decided on the ORT option for the proposed new York toll booth, including the factors that led to commissioning traffic and tolling studies and the evaluation of the HNTB and the CDM Smith reports resulting from the studies. Witnesses for the applicant described the analysis of the practicability the AET alternative as compared to ORT, as they relate to conditions specific to the Turnpike, and outlined the anticipated financial impacts that would result from implementing an AET system.

CRTC's pre-filed testimony and cross-examination of the applicant's witnesses focused on the benefits of an AET system and described the increasing use of AET systems in other states. Further, CRTC witnesses testified that improvements in video technology, increased use of electronic toll collection devices, and the collective enforcement agreement between Maine, New Hampshire, and Massachusetts would reduce the percentage of uncollectable toll transactions to less than 10%. CRTC raised questions as to the validity of the model used in the CDM Smith report. Specifically, it questioned whether the financial performance of an AET system, as outlined in the CDM Smith report and used by the applicant in its dismissal of this tolling method as a practicable alternative, was outdated and that the model overestimated the number of traffic diversions to avoid payment of the toll. CRTC also asserted that it was inappropriate for the applicant to have a separate evaluation of the construction capital costs and operational/maintenance differences between the two systems in its practicability determination.

In response to the questions raised by CRTC, the applicant testified that since the CDM Smith report was prepared, there have been improvements in video technology and license plate identification. The applicant also listed the actions it has undertaken to increase the use of electronic toll collection devices. The applicant stated that a large percentage of motorists who pay by cash are tourists. Thus, unlike other examples of tolled roads cited by the Intervenor where AET is used, these infrequent users of the Maine Turnpike are not expected to obtain an electronic toll collection device.

Regarding reciprocity between Maine, New Hampshire, and Massachusetts, the applicant testified that each state has different rules directing how the applicant may collect tolls from motorists from those States who travel on the Turnpike who do not use E-ZPass devices or pay cash. The number of violations or toll amounts that must be accrued before formal enforcement is triggered varies by State and uncollected tolls represent a risk to the revenue stream. The applicant stated that despite the reciprocity agreements, uncollected tolls from New Hampshire and Massachusetts motorists are still 46% and 53%, respectively. The applicant's pre-filed testimony noted that approximately 63% of all cash tolls are obtained from out-of-state motorists, including approximately 5% from Canada. The applicant stated during the public hearing, that given the challenges in obtaining driver information from other states and Canada, the 42% revenue loss predicted in the model is likely.

The applicant provided testimony that the model used in the CDM Smith report was an investment grade study to determine the feasibility of implementing an AET system. An investment grade study is performed when new revenue bonds for a new facility, an expansion, or a new toll plaza requires issuance of new revenue bonds. The applicant's witness testified that in this case, because a surcharge was deemed necessary to ensure revenue neutrality, an investment grade study was deemed appropriate for proper analysis. Further, the applicant pointed out that an investment grade study is reviewed by bond rating agencies, bond insurers, and bond buyers who evaluate potential changes to the revenue stream. The applicant's witness stated that due to the sensitivity of the model to the input parameters, the model's timeline for implementing an AET system was set at one year following the collected input data.

Specific to the practicability of implementing an AET system, the applicant testified that bonds issued by the applicant are revenue bonds and not general obligation bonds, and that revenue bonds are a claim against the revenue stream, not against assets owned by the applicant. As security for these bonds, the applicant pledges to raise tolls to meet any deficiencies in operations, capital, or debt service, and in the event that payments are not made, the Bond Trustee has the right to dictate toll rates. The applicant stated that imposing a surcharge is in effect a toll increase, and that increasing toll fees to make an AET financially feasible negatively impacts the applicant's or a Bond Trustee's ability to increase tolls in the future.

The applicant explained that calculating risk and revenue stream are determinants for bond rating, and it is this rating that affects the interest rate paid on a bond. The

applicant stated that the need to include a surcharge to the existing toll fee for pay-by-mail users in order to ensure the financial viability of an AET system added to the risk of implementing this system. In contrast, the applicant testified that it determined that there is no risk with implementing an ORT system because this system would be financially equivalent to the current tolling system. The applicant's witness testified that the MTA's determination that a surcharge would be necessary to address lost revenue from uncollectable toll transactions with an AET led to its decision that an AET system was not a practicable tolling method.

The CRTC's witnesses testified that an AET system would be less costly, more efficient, and would have little to no environmental impacts because installation of an AET system simply requires the construction of overhead gantries for the camera system. CRTC's pre-filed testimony stated that when a side-by-side comparison of an AET system with an added surcharge is compared with an ORT system that includes capital costs for a new toll plaza along with operating and maintenance costs over a 10-year period, then the AET system is more cost effective. The CRTC contended that this determination, in addition to the lack of any environmental impact from an AET system, should therefore be considered the most practicable alternative, less damaging to the environment.

In an effort to understand why capital costs were not included in the model calculations, the Intervenor's questioned the applicant's witnesses about a table in the CDM Smith report that predicted the "bottom line" cost difference between the two toll methods for a 10-year period. In response, the applicant explained that for ORT, the entirety of the capital costs would be depreciated over the life span of the toll plaza, a period between 35 to 40 years, not in the first 10 years of the project, and further stated that compressing the full capital costs of the proposed toll plaza into the first 10 years of the project would result in an overstatement of the cost difference between the two tolling methods.

The applicant's witnesses were questioned by the Intervenor's regarding the predicted number of traffic diversions as a result of a possible surcharge, and whether the CDM Smith model predicting traffic delays on local streets was calibrated to existing field conditions. The applicant's witnesses responded that the number of traffic diversions predicted by the CDM Smith model were taken by a second traffic engineer and used to predict traffic delays on local streets in a second traffic model. Given that this second model predicted significant delay and that there would be the expectation that motorists would be aware of these delays, the Intervenor's questioned whether the CDM Smith model was rerun to account for this and whether the predicted number of motorists diverting from the Turnpike would decrease. The applicant's witnesses stated that a second iteration of the CDM Smith model was not run based on the predicted traffic delays on local area streets predicted in the second traffic model. The Intervenor's were seeking clarification as to how the number of traffic diversions were calculated and did not submit its own evidence to challenge the applicant's conclusions.

d) Testimony from the General Public on Alternatives.

During the evening portion of the public hearing, approximately 28 persons provided testimony both opposed to and in support of the proposed project. The testimony in opposition to the proposed project generally asserted that the ORT alternative proposed by the applicant would be costlier, that there would be significant benefits from the AET alternative, and that an AET system would be safer, less noisy, and would result in a reduction in air pollution. Some speakers who opposed the proposed project testified that implementing an AET system is consistent with actions being taken by tolling agencies in other states and that this system would not result in any impacts to the environment. One person testified in favor of the proposed project, emphasizing the need for a cash toll collection option.

e) Department Analysis of Toll System Alternatives.

In its analysis of the reasonableness of impacts under the NRPA criteria the Department must consider the level of impacts to the resources resulting from the proposed activity (construction of the proposed toll plaza) and its use and the value of the impacted resources weighted against the practicability of any less damaging alternative. The mere existence of an alternative does not deem impacts to be unreasonable and result in the denial of a permit application for a proposed project.

The first step in the analysis of the reasonableness of impacts is the determination of the extent of any loss in wetland area, functions, or values. The proposed project will alter freshwater wetlands at 18 locations. These wetlands are mostly located immediately adjacent to the cleared right-of-way of the existing Turnpike. Except for two large, but isolated pockets of wetlands located at the center of the proposed new toll plaza which will be entirely lost, most of the wetland impacts will occur along the wetland edges. Typical impacts will be the result of culvert extensions or from shaping new road side slopes.

The application included a Functional Assessment, prepared by Sebago Technics and dated February 8, 2016. The Functional Assessment identified the relevant functions and values of the freshwater wetlands that will be altered as a result of the proposed project to be sediment and toxicant removal, nutrient removal, and wildlife habitat. The applicant proposes to mitigate for alterations to freshwater wetlands and uplands in the critical terrestrial habitat by making a contribution into the In-Lieu Fee program of the Maine Natural Resource Conservation Program, as discussed below.

The two isolated pockets of wetlands proposed to be filled entirely are 19,287 and 8,497 square feet respectively, and the functions these wetlands provide, sediment and toxicant removal and nutrient removal, will be lost. Although these are the primary functions of the two wetlands that will be filled, these wetland functions were also identified in the Functional Assessment to be the primary functions of other wetlands within the project site. Wetlands that provide sediment and toxicant removal and nutrient removal are not rare in this area. Given the size of the other

wetland areas providing these functions, and the amount of proposed alteration resulting from the project, the Functional Assessment did not identify any loss or degradation of other wetland functions or values. The Department finds that impacts along the edge of the wetlands will not significantly impair the functions of the wetlands proposed to be altered.

The Department agrees with the Intervenor, that the use of an AET system could result in little to no wetland impacts and thus would be less damaging to the environment. The Department recognizes that AET systems have been implemented in many states and for a diverse number of road systems. While the Intervenor argues that evidence of the usage by other road systems suggests that AET would be practicable in Maine, the applicant provided credible evidence of factors at the current York toll plaza that would affect the practicability of implementing an AET system. These factors include impacts to the revenue generated at the York toll plaza compared to the entire system, estimated to be 40% of the MTA's revenue; the percentage of out-of-State and Canadian traffic, their infrequent use of the Turnpike, and the difficulty in billing these users; and that the percentage of motorists using electronic toll collection devices (E-ZPass) passing through the current toll plaza is not likely to equal the percentage found on other roadways utilizing AET. The Department also recognizes that based on CDM Smith's model, an initial loss in revenue is predicted if an AET system is implemented and, as stated during the hearing, the loss of revenue could negatively affect the applicant's ability to issue and pay back bonds.

The record reflects that the applicant decided in 2014 that an AET system is not practicable. Following this decision, toll plaza design requirements were established, the process of site selection began, and site-specific design details were drafted by the applicant.

The Department finds credible the applicant's conclusions that conversion to an AET system represents a change in how tolls are collected, not only at the York Toll Plaza, but across the entire system, and that imposition of a surcharge to make an AET system financially viable constitutes a toll increase that limits the flexibility of the applicant to raise tolls in the future. When asked during the hearing if it was appropriate to use the model as a forecast tool for projecting further in the future, the applicant responded that the model is not designed to be used for that purpose because the input data would have changed and thus the reliability of the projected model output, whether a rate adjustment is necessary and what that adjustment should be, would be suspect.

Based on the factors which distinguish the southern section of the Turnpike from other toll roads that have adopted AET, the Department finds that the AET alternative has serious drawbacks in terms of its practicability. The Department finds that in light of the difficulties the applicant would have with an AET system at this location, the AET alternative is not practicable. The Department further recognizes that although conditions that influence the viability of each tolling method may change

over time, at some point the applicant must decide on the tolling method and move forward to design the project, and that it is impracticable to continue to reconsider the original decision as to which tolling method should be developed.

After consideration of the types of wetlands, impacts to the wetlands from the proposed project, the purpose of the proposed project, and the credible evidence of the impracticability of the AET alternative at this location, the Department finds the wetland impacts not to be unreasonable.

2) Analysis of Alternative Sites

a) Site Alternatives.

The applicant stated that it considered several possible locations for the proposed new toll plaza. The option of re-building at the existing site was dismissed because of several physical impediments that do not meet current highway safety standards for barrier toll plazas. The current site's drawbacks are its proximity to an interchange and a bridge, and that it is situated at the bottom of a hill and horizontal curve. These impediments do not provide adequate "decision sight distance" recommended by the Federal Highway Administration, and they negatively affect vehicle movement through the toll plaza. In addition, the applicant determined that required infrastructure repairs and environmental impacts associated with retrofitting the existing plaza would be costlier than constructing a new toll plaza in a different location. Initial consideration of a split plaza (one for northbound traffic and one for southbound traffic) was dismissed because of the likelihood of increased environmental impacts, impacts to abutters, and infrastructure redundancies (administration buildings, utilities, and access roads) resulting from two toll plazas.

In a technical memorandum titled "Southern Toll Plaza, Technical Memorandum on Alternatives Analysis," prepared by Jacobs Engineering Group, Inc. and dated October 13, 2015, five potential locations were evaluated based on the following categories: engineering and safety; abutter impacts; environmental impacts; cultural/historical resources costs; and logistical difficulties during construction. Initial capital and operational cost estimates for each location were also examined. The memorandum concluded that the selected site at Mile 8.8 is the most practicable location that meets the design criteria for a new toll plaza while minimizing impacts to the environment and to abutters. As design of the toll plaza at this location became more complete, the applicant was able to reduce the initial amount of wetland alteration and encroachments in significant vernal pool habitat.

Review of alternative sites for a similar ORT with cash lanes facility determined that while one location, at Mile 13.2, would likely result in less alteration to freshwater wetlands, use of that site would result in impacts to many more abutters than the selected site. This alternative site was not as advantageous from an engineering and safety perspective as well, and so was not selected by the applicant.

Based on the potential impacts to wetlands and abutters, as well as the engineering and safety considerations of the five sites the applicant evaluated, the Department concludes that impacts to the freshwater wetlands from the proposed project are not unreasonable provided that mitigation for these wetland impacts is addressed as outlined below.

b) Minimal Alteration.

In support of an application and to address the analysis of the reasonableness of any impacts of a proposed project, an applicant must demonstrate that the amount of freshwater wetland to be altered will be kept to the minimum amount necessary for meeting the overall purpose of the project. To minimize resource impacts, the applicant stated that it located the access road from Chase's Pond Road to the administration building in uplands, thereby avoiding encroachment in critical terrestrial habitat of significant vernal pools and freshwater wetlands to the greatest extent practicable. The location and orientation of the freshwater wetlands in relation to the highway within the project area allowed the applicant to limit impacts to the wetland edges. Additional minimization of wetland impacts was achieved by designing sideslopes at 2H:1V within the delineated wetland areas.

The Department finds that the road design and the angle of the sideslopes in and adjacent to the wetland edges resulted in the minimum amount of impacts necessary for the project.

c) Compensation.

In accordance with Chapter 310 §5(C), compensation may be required to achieve the goal of no net loss of wetland functions and values. Compensation is required when the Department determines that a freshwater wetland alteration will cause a wetland function or functions to be lost or degraded as identified by a functional assessment or by the Department's evaluation of the project. For the proposed project, because of the impacted or lost functions described above, the Department determined that compensation will be required.

The applicant proposes to make an In-Lieu Fee contribution to the Maine Natural Resource Conservation Program in the amount of \$281,649 to compensate for the permanent alteration of 54,022 square feet of freshwater wetlands. Prior to the start of construction, the applicant must submit a payment in the amount of \$281,649, payable to "Treasurer, State of Maine," and directed to the attention of the In-Lieu Fee Program Administrator at 17 State House Station, Augusta, Maine 04333.

The Department finds that the applicant has avoided and minimized freshwater wetland impacts to the greatest extent practicable, and that the proposed project represents the least environmentally damaging practicable site alternative that meets the overall purpose of the project, provided that prior to the start of project construction, the applicant submits the In-Lieu Fee payment as described above.

B. HABITATS

The applicant's proposed project will alter 62,195 square feet (1.43 acres) of upland within the critical terrestrial habitat of significant vernal pools and wetlands associated with habitat for rare, threatened, and endangered species. According to the Department's Geographic Information System database there are no mapped Essential Habitats located at the site. The Maine Natural Areas Program's assessment, in a letter dated March 26, 2017, was that its existing maps and documents did not include any records documenting the existence of rare or unique botanical features within the area proposed for development on the project site.

1) Significant Vernal Pools

To address potential impacts to significant vernal pools and wetlands associated with habitat for rare, threatened, and endangered species the applicant submitted, in addition to its wetland report, a vernal pool survey of the project area. The vernal pool survey identified four vernal pools (VP 54-2, VP 54-3, VP 54-4, and VP 56-1) that meet the definition of significant vernal pool, pursuant to the Department's *Significant Wildlife Habitat* Rules, Chapter 335 § 9(A)(6)&(7). As a result, the freshwater wetlands where these significant vernal pools are located are classified as wetlands of special significance, pursuant to Chapter 310 § 4 of the Department's *Wetlands and Waterbodies* Rules. The applicant determined that two other vernal pools (VP 13-1 on the west side and VP 19-1 on the east side of the project site) were the result of excavation. Although each of those pools contained high numbers of amphibian egg masses, they are not considered significant vernal pools because they are human-made. VP 13-1 is within 500 feet of the emergent wetland to the south and the area between the two waterbodies is suspected by staff from the Maine Department of Inland Fisheries and Wildlife (MDIFW) to be used as a travel corridor by ribbon snakes and spotted turtles. Spotted turtles are listed as threatened under the Maine Endangered Species Act, and ribbon snakes are listed as species of special concern.

Of the four significant vernal pools, VP 54-4 was determined to be significant because a 2008 survey documented the presence of fairy shrimp in the pool. Although vernal pool surveys conducted in 2015 and 2016 did not document the presence of any indicator species in this vernal pool, based on Chapter 335 of the Department's rules, VP 54-4 is still considered to be a significant vernal pool. VP 54-4 is located less than 100 feet from the clearing limit of the existing highway, and the proposed road widening for the toll booth lanes will further encroach on the critical terrestrial habitat of this vernal pool, reducing the existing habitat. This vernal pool is separated from the highway by a line of ledge that runs parallel to the Turnpike. Approximately 53,729 square feet of upland and 4,064 square feet of wetland will be altered within the critical terrestrial habitat of VP 54-4.

The proposed access drive that extends from Chase's Pond Road to the administration building will be located between the significant vernal pools on the 32.6-acre parcel owned by the applicant, and will encroach on the critical terrestrial habitat of significant

vernal pools VP 54-2 and VP 56-1. Approximately 8,466 square feet of upland will be altered within the critical terrestrial habitat of these significant vernal pools.

Following an August 28, 2015 site visit by staff from the MDIFW and the Department, which was attended by representatives of the applicant, MDIFW stated in comments dated November 13, 2015 that the loss of forested habitat and potential changes to pool hydrology from the proposed project could negatively affect VP 54-4. MDIFW also stated that the access drive will have an indeterminate negative effect on wildlife movements between the significant vernal pools on either side of the access drive.

Chapter 335 of the Department's rules interprets and elaborates on the NRPA criteria pertaining to wildlife habitat. The rules guide the Department in its determination of whether a project's impacts would be unreasonable. A proposed project would generally be considered to result in an unreasonable impact if it would degrade the significant wildlife habitat, disturb the subject wildlife, or affect the continued use of the significant wildlife habitat by the subject wildlife, either during or as a result of the activity, and there is a practicable alternative to the project that would be less damaging to the environment. Like the analysis for wetland impacts, each application for an NRPA permit that involves a significant vernal pool alteration must provide an analysis of alternatives. The extent and severity of the impacts are considered with the practicability of any alternatives in the determination of whether the impacts would be unreasonable.

a) Avoidance.

The applicant submitted an alternatives analysis for the proposed project completed by Sebago Technics, Inc. A full discussion of the applicant's alternatives analysis and the evidence submitted on this issue by the Intervenors and members of the public, as well as the Department's findings on the practicability of the AET alternative, are in Finding 4(A) of this Order.

The applicant stated that its proposed access drive from Chase's Pond Road to the administration building that will service the toll plaza is designed to avoid any direct impact on the vernal pool depressions and, to the greatest extent practicable, the wetlands on the site. Given the location and orientation of the significant vernal pools and other protected natural resources, the applicant stated that impacts to the critical terrestrial habitat of the significant vernal pools cannot be entirely avoided.

As with wetland impacts, the reasonableness of impacts to significant vernal pools is based primarily on the determination of the extent of any loss in habitat area, functions, or values. The proposed project will encroach on the critical terrestrial habitat of three significant vernal pools, but will not affect any of the pool depressions. Encroachment on VP 54-4 is unavoidable given the pool's proximity to the existing highway. VP 54-4 was determined to be significant because of the presence of fairy shrimp. Because fairy shrimp are only found in the pool depression and do not migrate from pool to adjacent upland or wetland, the loss of critical terrestrial habitat will not affect the continued used of this vernal pool by fairy

shrimp, provided the forest canopy over the pool depression remains intact. Approximately 25 feet of natural forest cover will remain around VP 54-4 following completion of the proposed project. The construction and use of the access road from Chase's Pond Road to the administration building will result in only minimal disturbance to the critical terrestrial habitat of VP 56-1, VP 54-2, and VP 54-3. The access road could affect the movement of wildlife that use the pools. Given that the access road will be located in the uplands, and avoids wetlands and drainage swales leading to or from the significant vernal pools, and that the majority of the forest canopy and duff layer around the pools will remain undisturbed, impacts to wildlife movement through this area are expected to be minimal.

As with the wetland impacts, the Department finds that the amount of impact to the edges of the significant vernal pool habitat is not unreasonable given the drawbacks of the AET alternative, which would otherwise allow an avoidance of impacts to the critical terrestrial habitat. The impacts resulting from the proposed project are not anticipated to result in a loss in significant vernal pool functions or values. The Department finds that the practicability of implementing an AET system is low, and that the impacts to significant vernal pools are reasonable in light of the public need for the project and the project purpose.

b) Minimal Alteration and Habitat Maintenance.

The amount of significant wildlife habitat to be altered must be kept to the minimum amount necessary for meeting the overall purpose of the project. The applicant stated that it considered several design layouts and chose the one that meets the project goals while minimizing impacts to the habitat, and that due to the location of the significant vernal pools, there is only one possible point of entry for the access road from Chase's Pond Road to the location of the proposed administrative building that avoids the critical terrestrial habitat around the significant vernal pools and other wetlands. The access drive and development around the administration building were configured to limit disturbance of the critical terrestrial habitat around the significant vernal pools to the outermost edges of the 250-foot setback of the critical terrestrial habitats. The applicant is proposing to alter a small portion of the critical terrestrial habitat of significant vernal pools VP 56-1, VP 54-2, and VP 54-3. As noted above, the eastern portion of the critical terrestrial habitat associated with VP 54-4 has already been compromised by the existing Turnpike, and the proposed project will expand the highway closer to the vernal pool depression.

The Department finds that the proposed location of the access road and administration building results in the minimum amount of impacts necessary for the project.

c) Compensation.

In accordance with Chapter 335 §3(D)(1), compensation is required when the Department determines that an impact to significant wildlife habitat will cause habitat functions or values to be lost or degraded as identified by the Department. After

considering several compensation options, the applicant proposes to make a contribution into the In-Lieu Fee (ILF) program of the Maine Natural Resource Conservation Program. Compensation for project impacts is discussed further in Finding 4(A).

The Department finds that the applicant has avoided and minimized impacts to significant wildlife habitat to the greatest extent practicable, and that the proposed project represents the least environmentally damaging alternative that meets the overall purpose of the project provided that, prior to the start of construction, the applicant submits the ILF payment as described in Finding 4(A).

The applicant's compliance with Chapter 335 is not an independent criterion equivalent to the standards of 38 M.R.S. § 480-D that must be met as a condition of approval, but the availability of alternatives and their practicability are factors considered by the Department in its determination as to whether the proposed project will result in unreasonable impacts. The Department balances the extent of the impacts to the resource and the relevant uses of the resource with the availability and feasibility of the alternatives. Based on a balancing of the extent of the impacts and the nature of the alternatives in light of the purpose of the project, the Department finds that the proposed project will not result in unreasonable impacts under the wildlife habitat criteria set forth in 38 M.R.S. § 480-D.

2) Rare, Threatened, and Endangered Species

The applicant identified several rare, threatened, and endangered species that may be present within the project site. These include the northern long-eared bat, the New England cottontail rabbit, the ribbon snake, and the spotted turtle.

The application included a bat acoustic survey performed by Stantec Consulting Services, Inc, and dated September 22, 2015. During two nights of operation in July 2015, sensors identified almost 1,500 bat passes. Of these, five passes were determined to be from northern long-eared bats. Based on the limited number of passes from northern long-eared bats, the survey concluded that this species of bat is not expected to use the forests in and around the project site. The Department finds that the proposed project will not unreasonably affect the forested habitat used by northern long-eared bats.

The application included excerpts from a New England cottontail pellet survey performed by Normandeau Associates, Inc. and dated July 2010. The report stated that the project area contains potential habitat for cottontails at Mile 7.3, the location of the existing toll plaza. Although no evidence of the presence of New England cottontails was found, the report did not consider the absence of evidence of cottontails in the area to be conclusive. In its comments, dated November 13, 2015, MDIFW stated that although New England cottontails have not been documented at the site of the proposed toll plaza and no evidence of their presence was noted during the August 28, 2015 site visit, thick brush cover which allows for dispersal of rabbits can be found along the east side of the project site and would be the most likely location for an impact to New England cottontails to

occur, if they are present. The west side of the project site had very little early successional habitat which would be used by New England cottontails. The Department finds that the proposed project will not unreasonably affect the habitat used by New England cottontails.

MDIFW commented that populations of ribbon snake and spotted turtles have been documented at the emergent wetland located on the west side of the project site and north of the proposed administration building. The April 2016 vernal pool survey documented the presence of a spotted turtle at VP 13-1 which is approximately 300 to 400 feet north of the emergent wetland. MDIFW commented that it is likely that both snakes and turtles travel between these two areas following a seasonal outlet from the emergent wetland, which is channelized in a roadside ditch running north along the highway before turning northwest and into the woods, returning to a natural stream. MDIFW further commented that maintaining the hydrological connection between these two wetlands is critical to the reptiles that move through this area. The proposed project includes lane widening and installation of new side slopes beginning at a point approximately 150 feet south of the outlet of the emergent wetland and continuing approximately 450 feet north, beyond the point where the stream cuts northwest into the woods. Approximately 20,287 square feet of upland; 3,900 square feet of wetland; and 20 linear feet of stream between the emergent wetland and VP 13-1 will be altered. The applicant proposes to maintain the natural drainage between the emergent wetland and VP 13-1; thus, although altered, the hydrologic connection between the two waterbodies will remain. The cumulative wildlife habitat impacts resulting from the proposed project will be approximately 25,900 square feet, including approximately 5,619 square feet of wetland at four locations and approximately 20 linear feet of stream channel. The Department finds that the applicant's plan will adequately protect the travel corridor for snakes and turtles.

During the August 28, 2015 site visit, a spotted turtle nest was found by MDIFW staff next to a culvert on the eastern edge of the highway. The discovery provided new evidence of a breeding population on the east side of the project site. At this location, the proposed project will encroach approximately 20 to 25 feet into the adjacent wetland where the turtle nest was found.

In its November 13, 2015 comments, MDIFW stated that the proposed project is expected to adversely impact populations of ribbon snakes and spotted turtles because of direct impacts to suitable wetland habitat and forested buffers and from increased noise, lights, and ground vibration. MDIFW described several mitigation options which the applicant could propose to compensate for these impacts. One option was to replace a 36-inch culvert crossing north of the emergent wetland with bridges or box culverts to facilitate wildlife movement under the Turnpike to allow connectivity between the two populations of turtles. The applicant did not propose this form of mitigation due to the high costs associated with a bridge or large culvert crossing, and due to the length of the culvert that will lack natural light that is desirable for a wildlife tunnel.

The applicant consulted with MDIFW to develop acceptable plans to address potential impacts to wildlife and wildlife habitat pursuant to the Maine Endangered Species Act.

To account for the predicted loss of wildlife habitat, the applicant and MDIFW negotiated a Memorandum of Understanding (MOU) that formalizes a proposed mitigation plan for impacts to wildlife habitat resulting from the proposed project if a permit is issued for the project. The MOU was signed on October 17, 2016 and included the applicant, MDIFW and the Maine Department of Transportation (MDOT) as signatories. In the MOU, the applicant agrees to place the remaining undeveloped portion of the 32.6-acre parcel adjacent to the Turnpike under a conservation easement for the protection of habitat for spotted turtles, ribbon snakes, and other species, to erect wildlife barrier fencing in the vicinity of the new toll plaza, and to provide funds, in the amount of \$170,000, to the MDOT for a planned wildlife connectivity crossing (including wildlife barrier fencing) at a site on State Route 236 in Eliot, approximately 11 miles to the southwest. A copy of the MOU was included in the application. The wildlife connectivity crossing, which would be a tunnel under State Route 236, would be located on a stretch of road that bisects two wetland areas, where there has been a high incidence of documented turtle mortality as a result of turtles trying to cross the road. The Department finds that this proposed connectivity crossing proposal will reduce turtle mortality along State Route 236 and mitigates for encroachment of turtle habitat along the project site.

The final design specifications of the wildlife barrier fencing and its specific location around the project site have not been determined. Both the applicant and MDIFW agreed that, prior to the start of construction, the applicant will submit to the Department final design specifications and plans showing the location of the wildlife barrier fencing as approved by MDIFW.

At the time of the signing of the MOU, the final language of the conservation easement and its specific location around the project site had not been determined. Both the applicant and MDIFW agreed that, prior to the start of construction, the applicant will submit to the Department the recorded conservation easement protecting the parcel identified in the MOU. The Department finds that the conservation easement on the remaining portion of the 32.6-acre parcel and wildlife barrier fencing along the Turnpike will protect the habitat and reduce mortality of spotted turtles on the Turnpike.

In accordance with 38 M.R.S. §480-D(3), the Department may consider proposed mitigation in determining whether an activity will result in an unreasonable harm to significant wildlife habitat. The Department finds that the applicant has made adequate provision for compensation for the potential impacts to wildlife and wildlife habitat provided that the applicant submits the recorded conservation easement and final design specifications of the wildlife barrier fencing and plans showing the location of the wildlife barrier fencing to the Department for review prior to the start of construction.

The Department finds that the activity will not unreasonably harm any freshwater wetland plant habitat, threatened or endangered plant habitat, aquatic or adjacent upland habitat, travel corridor, freshwater, estuarine or marine fisheries or other aquatic life provided that the applicant complies with the requirements of the MOU, and final design specifications and plans showing the location of the wildlife barrier fencing and the

recorded conservation easement are submitted to the Department for review prior to the start of construction.

5. WATER QUALITY:

The waters that are or may be affected by the proposed project are currently classified (38 M.R.S. §468(9)) as Class B. As discussed in Finding 3, the applicant proposes to use erosion and sediment control during construction to minimize impacts to water quality from siltation.

The Department does not anticipate that the proposed project will violate any state water quality law, including those governing the classification of the State's waters.

6. OTHER NRPA STANDARDS:

The Department finds, based on the design, proposed construction methods, and location of the proposed project, the proposed project will not interfere with the natural flow of any surface or subsurface waters (38 M.R.S. §480-D(4)) and will not cause or increase flooding (38 M.R.S. §480-D(6)). The proposed project is not located in a coastal sand dune system (38 M.R.S. §480-D(7)), is not a crossing of an outstanding river segment (38 M.R.S. §480-D(8)), does not involve dredge spoils disposal or the transport of dredge spoils by water (38 M.R.S. §480-D(9)), and does not involve withdrawal of groundwater from a significant groundwater well (38 M.R.S. §480-D(10)).

7. SITE LOCATION OF DEVELOPMENT ACT GENERAL PERMIT:

The applicant filed a Notice of Intent to Comply with attachments providing evidence to demonstrate that for the proposed project, it will comply with the terms and conditions of the General Permit for the Maine Turnpike Authority, Department Order DEP #L-26825-TP-A-N, dated February 29, 2016. A development authorized by the General Permit is required to meet all the applicable requirements of the Site Law pursuant to 38 M.R.S. § 484, the specific conditions listed in the General Permit, and any conditions attached to an approval of a Notice of Intent.

Standards of the General Permit.

A. Financial Capacity (38 M.R.S. § 484(1)): The applicant is required to have the financial capacity and technical ability to develop the proposed project in a manner consistent with state environmental standards and consistent with the Site Law.

Funding commitments are authorized by the applicant's Board of Directors through the applicant's Four Year Capital Investment Plan, Thirty Year Financial Plan, and annual Reserve Maintenance Deposit requirements. The applicant submitted a copy of the draft 4-Year Capital Investment Plan for the period 2018-2021 which listed the proposed project. The Plan indicates that this project was funded in 2017.

The Department finds that the applicant has demonstrated adequate financial capacity to comply with Department standards.

B. No Adverse Effect on the Natural Environment (38 M.R.S. § 484(3)): The construction and operation of the proposed project, may not adversely affect existing uses, scenic character, air quality, water quality or other natural resources.

Analysis of the evidence regarding impacts to the natural environment is found in Findings 2, 4, and 5.

The Department finds that the applicant has demonstrated that the proposed project will not adversely affect the existing uses, scenic character, or natural resources within the Town of York.

C. Soil Types (38 M.R.S. § 484(4)): The proposed project is required to be built on soil types that are suitable to the nature of the undertaking.

The applicant employs or contracts with geotechnical engineers to evaluate the suitability of existing soils and determine the need for engineering practices to address soil limitations. The applicant submitted a soil survey map based on the soils found at the project site and a geotechnical report. This report was prepared by a professional engineer and reviewed by staff from the Division of Environmental Assessment (DEA) of the Bureau of Water Quality.

The Department finds that, based on this report and DEA's review, the soils on the project site present no limitations to the proposed project that cannot be overcome through standard engineering practices.

D. Storm Water Management and Erosion Control (38 M.R.S. § 484(4-A)): The proposed project is required to comply with the Storm Water Management and Erosion Control Standard of the Site Law through implementation of the General Permit requirements. The proposed project triggers the thresholds of the Basic, General, and Flooding Standards of the Chapter 500, *Stormwater Management* (06-096 C.M.R. ch. 500, effective August 12, 2015), thus the applicant is required to apply design and engineering measures to the extent practicable such that project drainage avoids adverse impacts to offsite property resulting from project-related peak flows.

A full analysis of the evidence pertaining to erosion control is found in Finding 3 above.

The applicant submitted a stormwater management plan based on the Basic, General, and Flooding standards contained in Chapter 500 Stormwater Management rules. The proposed stormwater management system consists of drainage swales, catch basins, a subsurface drainage system, and nine vegetated underdrained soil filters. The stormwater management system proposed by the applicant was reviewed by, and revised in response to comments from, the Bureau of Land Resources. After a final review, the Bureau of Land Resources commented that the proposed stormwater management system is

designed to the greatest extent practicable with the General and Flooding Standards contained in Chapter 500.

Based on the stormwater system's design and the Bureau of Land Resources' review, the Department finds that the applicant has made adequate provision to ensure that the proposed project will meet the General Standards contained in Chapter 500 to the greatest extent practicable.

E. Groundwater (38 M.R.S. § 484(5)): The applicant is required to construct and operate the proposed project in a manner that will not pose an unreasonable risk that a discharge to a significant groundwater aquifer will occur.

The applicant's engineering staff and consultants will develop viable and sustainable water extraction practices for both potable and production systems. The applicant's Environmental Coordinator, in conjunction with its environmental consulting firm, has developed and continuously updates sound management practices for, and training in, the storage of hazardous materials. These actions are directed toward minimizing impacts to waters recharging the groundwater regime.

The project site is not located over a mapped sand and gravel aquifer. The proposed project does not propose any withdrawal from, or discharge to, the groundwater.

The Department finds that the proposed project will not have an unreasonable adverse effect on groundwater quality or quantity.

F. Infrastructure (38 M.R.S. § 484(6)): The applicant is required to make adequate provisions for utilities, including water supplies, sewerage facilities and solid waste disposal required for the proposed project, and the proposed project may not have an unreasonable adverse effect on the existing or proposed utilities in the municipality or area served by those services.

The applicant identified approximately 1,500 linear feet of water main within the project area that must be relocated and has initiated coordination with the York Water District to ensure that there will be no unreasonable burden on, disruption of, or interference with, service. Wastewater will be disposed of by an individual subsurface wastewater disposal system designed to meet the requirements of the Maine State Plumbing Code. This information was reviewed by DEA. The applicant's Standard Specifications for contractors provides detailed requirements to ensure that all solid, special, universal, and hazardous wastes associated with transportation projects are managed in accordance with State and Federal Requirements.

The Department finds that the applicant has made adequate provisions for utilities, including water supplies, sewerage facilities and solid waste disposal.

G. Flooding (38 M.R.S. § 484(7)): The proposed project must not unreasonably cause or increase the flooding of the alteration area or adjacent properties nor create an unreasonable flood hazard to any structure.

Approximately 0.3 acres of development from the proposed project will be located within the 100-year flood plain. The applicant submitted a stormwater management plan to control stormwater runoff from the project site. Stormwater controls will reduce the rate of runoff on impervious surface not currently treated; thus, increased flooding of the project area or adjacent properties is not anticipated.

The Department finds that the proposed project is unlikely to cause or increase flooding or cause an unreasonable flood hazard to any structure.

H. Blasting (38 M.R.S. § 484(9)): The applicant is required to conduct any blasting for the proposed project in accordance with the standards set forth in 38 M.R.S. § 490-Z (14).

The applicant's Standard Specifications for contractors (Section 105.2.7) provide detailed requirements for blasting. These standard specifications were reviewed by staff from DEA, and based on DEA's, were revised to ensure compliance with 38 M.R.S. § 484(9).

The Department finds that, with those revisions, the applicant has made adequate provision to ensure that any blasting for the proposed project will be conducted in accordance with the standards in 38 M.R.S. § 490-Z (14).

I. Public Involvement: The applicant is required to treat the proposed project as a "Substantial Public Interest Project" under its existing Public Participation Plan, effective May 2010, that includes at least one preliminary public meeting and one final public meeting on the proposed project, depending on the scope of the project and anticipated level of public interest. The applicant is also required to notify the public in accordance with Chapter 2 of the Department's Rules for the proposed project.

The NOI included a list of the public meetings held regarding the proposed project for the period 2006 through 2016. The NOI also included printed material available to attendees of the October 17, 2016 Public Informational Meeting.

The Department finds that the applicant has made adequate provision to ensure that the general public has appropriate notice of the proposed project.

The applicant is authorized to construct the facility in accordance with the applicant's Notice of Intent, received by the Department on October 19, 2016 in accordance with the terms and conditions of the General Permit.

Natural Resources Protection Act Conclusions

BASED on the above findings of fact, and subject to the conditions listed below, the Department makes the following conclusions pursuant to the Natural Resources Protection Act, 38 M.R.S. §§ 480-A–480-JJ, and Section 401 of the Federal Water Pollution Control Act:

- A. The proposed activity will not unreasonably interfere with existing scenic, aesthetic, recreational, or navigational uses provided that a final photometric plan is submitted to the Department prior to the start of construction, as outlined in Finding 2.
- B. The proposed activity will not cause unreasonable erosion of soil or sediment provided that the final erosion control plan is submitted to the Department prior to the start of construction as discussed in Finding 3.
- C. The proposed activity will not unreasonably inhibit the natural transfer of soil from the terrestrial to the marine or freshwater environment.
- D. The proposed activity will not unreasonably harm any significant wildlife habitat, freshwater wetland plant habitat, threatened or endangered plant habitat, aquatic or adjacent upland habitat, travel corridor, freshwater, estuarine, or marine fisheries or other aquatic life provided that the applicant complies with the requirements of the MOU with MDIFW and DOT and final design specifications and plans showing the location of the wildlife barrier fencing and the recorded conservation easement are submitted to the Department prior to the start of construction as outlined in Finding 4; and that, prior to the start of construction, the applicant makes a contribution to the ILF program as discussed in Finding 4.
- E. The proposed activity will not unreasonably interfere with the natural flow of any surface or subsurface waters.
- F. The proposed activity will not violate any state water quality law including those governing the classifications of the State's waters.
- G. The proposed activity will not unreasonably cause or increase the flooding of the alteration area or adjacent properties.
- H. The proposed activity is not on or adjacent to a sand dune.
- I. The proposed activity is not on an outstanding river segment as noted in 38 M.R.S. § 480-P.

THEREFORE, the Department APPROVES the above noted application of the MAINE TURNPIKE AUTHORITY to construct a new barrier toll plaza as described in Finding 1, SUBJECT TO THE ATTACHED CONDITIONS, and all applicable standards and regulations:

1. Standard Conditions of Approval, a copy attached.
2. The applicant shall take all necessary measures to ensure that its activities or those of its agents do not result in measurable erosion of soil on the site during the construction of the project covered by this approval.
3. Severability. The invalidity or unenforceability of any provision, or part thereof, of this License shall not affect the remainder of the provision or any other provisions. This License shall be construed and enforced in all respects as if such invalid or unenforceable provision or part thereof had been omitted.
4. Prior to the start of construction, the applicant shall submit the recorded conservation easement to the Department.
5. Prior to the start of construction, the applicant shall submit a final photometric plan to the Department for review.
6. Prior to the start of construction, the applicant shall submit the erosion control plan to the Department for review and approval.
7. Prior to the start of construction, the applicant shall submit final design specifications and plans showing the location of the wildlife barrier fencing to the Department for review.
8. Prior to the start of construction, the applicant shall submit a payment in the amount of \$281,649, payable to "Treasurer, State of Maine", to the attention of the In-Lieu Fee Program Administrator at 17 State House Station, Augusta, Maine 04333.

THIS APPROVAL DOES NOT CONSTITUTE OR SUBSTITUTE FOR ANY OTHER REQUIRED STATE, FEDERAL OR LOCAL APPROVALS NOR DOES IT VERIFY COMPLIANCE WITH ANY APPLICABLE SHORELAND ZONING ORDINANCES.

DONE AND DATED IN AUGUSTA, MAINE, THIS 14th DAY OF September, 2017.

DEPARTMENT OF ENVIRONMENTAL PROTECTION

BY: Melanie [Signature] for
For: Paul Mercer, Commissioner

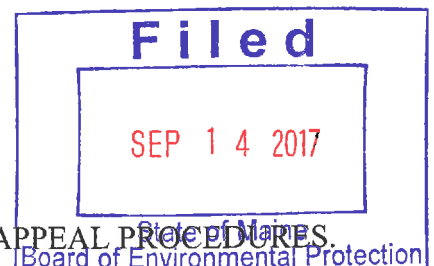

PLEASE NOTE THE ATTACHED SHEET FOR GUIDANCE ON APPEAL PROCEDURES.

RLG/L27241ANBN/ATS#81093&81263



Natural Resources Protection Act (NRPA) Standard Conditions

THE FOLLOWING STANDARD CONDITIONS SHALL APPLY TO ALL PERMITS GRANTED UNDER THE NATURAL RESOURCES PROTECTION ACT, 38 M.R.S. § 480-A ET SEQ., UNLESS OTHERWISE SPECIFICALLY STATED IN THE PERMIT.

- A. Approval of Variations From Plans. The granting of this permit is dependent upon and limited to the proposals and plans contained in the application and supporting documents submitted and affirmed to by the applicant. Any variation from these plans, proposals, and supporting documents is subject to review and approval prior to implementation.
- B. Compliance With All Applicable Laws. The applicant shall secure and comply with all applicable federal, state, and local licenses, permits, authorizations, conditions, agreements, and orders prior to or during construction and operation, as appropriate.
- C. Erosion Control. The applicant shall take all necessary measures to ensure that his activities or those of his agents do not result in measurable erosion of soils on the site during the construction and operation of the project covered by this Approval.
- D. Compliance With Conditions. Should the project be found, at any time, not to be in compliance with any of the Conditions of this Approval, or should the applicant construct or operate this development in any way other the specified in the Application or Supporting Documents, as modified by the Conditions of this Approval, then the terms of this Approval shall be considered to have been violated.
- E. Time frame for approvals. If construction or operation of the activity is not begun within four years, this permit shall lapse and the applicant shall reapply to the Board for a new permit. The applicant may not begin construction or operation of the activity until a new permit is granted. Reapplications for permits may include information submitted in the initial application by reference. This approval, if construction is begun within the four-year time frame, is valid for seven years. If construction is not completed within the seven-year time frame, the applicant must reapply for, and receive, approval prior to continuing construction.
- F. No Construction Equipment Below High Water. No construction equipment used in the undertaking of an approved activity is allowed below the mean high water line unless otherwise specified by this permit.
- G. Permit Included In Contract Bids. A copy of this permit must be included in or attached to all contract bid specifications for the approved activity.
- H. Permit Shown To Contractor. Work done by a contractor pursuant to this permit shall not begin before the contractor has been shown by the applicant a copy of this permit.

Revised September 2016



DEP INFORMATION SHEET

Appealing a Department Licensing Decision

Dated: March 2012

Contact: (207) 287-2811

SUMMARY

There are two methods available to an aggrieved person seeking to appeal a licensing decision made by the Department of Environmental Protection's ("DEP") Commissioner: (1) in an administrative process before the Board of Environmental Protection ("Board"); or (2) in a judicial process before Maine's Superior Court. An aggrieved person seeking review of a licensing decision over which the Board had original jurisdiction may seek judicial review in Maine's Superior Court.

A judicial appeal of final action by the Commissioner or the Board regarding an application for an expedited wind energy development (35-A M.R.S.A. § 3451(4)) or a general permit for an offshore wind energy demonstration project (38 M.R.S.A. § 480-HH(1)) or a general permit for a tidal energy demonstration project (38 M.R.S.A. § 636-A) must be taken to the Supreme Judicial Court sitting as the Law Court.

This INFORMATION SHEET, in conjunction with a review of the statutory and regulatory provisions referred to herein, can help a person to understand his or her rights and obligations in filing an administrative or judicial appeal.

I. ADMINISTRATIVE APPEALS TO THE BOARD

LEGAL REFERENCES

The laws concerning the DEP's *Organization and Powers*, 38 M.R.S.A. §§ 341-D(4) & 346, the *Maine Administrative Procedure Act*, 5 M.R.S.A. § 11001, and the DEP's *Rules Concerning the Processing of Applications and Other Administrative Matters* ("Chapter 2"), 06-096 CMR 2 (April 1, 2003).

HOW LONG YOU HAVE TO SUBMIT AN APPEAL TO THE BOARD

The Board must receive a written appeal within 30 days of the date on which the Commissioner's decision was filed with the Board. Appeals filed after 30 calendar days of the date on which the Commissioner's decision was filed with the Board will be rejected.

HOW TO SUBMIT AN APPEAL TO THE BOARD

Signed original appeal documents must be sent to: Chair, Board of Environmental Protection, c/o Department of Environmental Protection, 17 State House Station, Augusta, ME 04333-0017; faxes are acceptable for purposes of meeting the deadline when followed by the Board's receipt of mailed original documents within five (5) working days. Receipt on a particular day must be by 5:00 PM at DEP's offices in Augusta; materials received after 5:00 PM are not considered received until the following day. The person appealing a licensing decision must also send the DEP's Commissioner a copy of the appeal documents and if the person appealing is not the applicant in the license proceeding at issue the applicant must also be sent a copy of the appeal documents. All of the information listed in the next section must be submitted at the time the appeal is filed. Only the extraordinary circumstances described at the end of that section will justify evidence not in the DEP's record at the time of decision being added to the record for consideration by the Board as part of an appeal.

WHAT YOUR APPEAL PAPERWORK MUST CONTAIN

Appeal materials must contain the following information at the time submitted:

1. *Aggrieved Status.* The appeal must explain how the person filing the appeal has standing to maintain an appeal. This requires an explanation of how the person filing the appeal may suffer a particularized injury as a result of the Commissioner's decision.
2. *The findings, conclusions or conditions objected to or believed to be in error.* Specific references and facts regarding the appellant's issues with the decision must be provided in the notice of appeal.
3. *The basis of the objections or challenge.* If possible, specific regulations, statutes or other facts should be referenced. This may include citing omissions of relevant requirements, and errors believed to have been made in interpretations, conclusions, and relevant requirements.
4. *The remedy sought.* This can range from reversal of the Commissioner's decision on the license or permit to changes in specific permit conditions.
5. *All the matters to be contested.* The Board will limit its consideration to those arguments specifically raised in the written notice of appeal.
6. *Request for hearing.* The Board will hear presentations on appeals at its regularly scheduled meetings, unless a public hearing on the appeal is requested and granted. A request for public hearing on an appeal must be filed as part of the notice of appeal.
7. *New or additional evidence to be offered.* The Board may allow new or additional evidence, referred to as supplemental evidence, to be considered by the Board in an appeal only when the evidence is relevant and material and that the person seeking to add information to the record can show due diligence in bringing the evidence to the DEP's attention at the earliest possible time in the licensing process or that the evidence itself is newly discovered and could not have been presented earlier in the process. Specific requirements for additional evidence are found in Chapter 2.

OTHER CONSIDERATIONS IN APPEALING A DECISION TO THE BOARD

1. *Be familiar with all relevant material in the DEP record.* A license application file is public information, subject to any applicable statutory exceptions, made easily accessible by DEP. Upon request, the DEP will make the material available during normal working hours, provide space to review the file, and provide opportunity for photocopying materials. There is a charge for copies or copying services.
2. *Be familiar with the regulations and laws under which the application was processed, and the procedural rules governing your appeal.* DEP staff will provide this information on request and answer questions regarding applicable requirements.
3. *The filing of an appeal does not operate as a stay to any decision.* If a license has been granted and it has been appealed the license normally remains in effect pending the processing of the appeal. A license holder may proceed with a project pending the outcome of an appeal but the license holder runs the risk of the decision being reversed or modified as a result of the appeal.

WHAT TO EXPECT ONCE YOU FILE A TIMELY APPEAL WITH THE BOARD

The Board will formally acknowledge receipt of an appeal, including the name of the DEP project manager assigned to the specific appeal. The notice of appeal, any materials accepted by the Board Chair as supplementary evidence, and any materials submitted in response to the appeal will be sent to Board members with a recommendation from DEP staff. Persons filing appeals and interested persons are notified in advance of the date set for Board consideration of an appeal or request for public hearing. With or without holding a public hearing, the Board may affirm, amend, or reverse a Commissioner decision or remand the matter to the Commissioner for further proceedings. The Board will notify the appellant, a license holder, and interested persons of its decision.

II. JUDICIAL APPEALS

Maine law generally allows aggrieved persons to appeal final Commissioner or Board licensing decisions to Maine's Superior Court, see 38 M.R.S.A. § 346(1); 06-096 CMR 2; 5 M.R.S.A. § 11001; & M.R. Civ. P 80C. A party's appeal must be filed with the Superior Court within 30 days of receipt of notice of the Board's or the Commissioner's decision. For any other person, an appeal must be filed within 40 days of the date the decision was rendered. Failure to file a timely appeal will result in the Board's or the Commissioner's decision becoming final.

An appeal to court of a license decision regarding an expedited wind energy development, a general permit for an offshore wind energy demonstration project, or a general permit for a tidal energy demonstration project may only be taken directly to the Maine Supreme Judicial Court. See 38 M.R.S.A. § 346(4).

Maine's Administrative Procedure Act, DEP statutes governing a particular matter, and the Maine Rules of Civil Procedure must be consulted for the substantive and procedural details applicable to judicial appeals.

ADDITIONAL INFORMATION

If you have questions or need additional information on the appeal process, for administrative appeals contact the Board's Executive Analyst at (207) 287-2452 or for judicial appeals contact the court clerk's office in which your appeal will be filed.

Note: The DEP provides this INFORMATION SHEET for general guidance only; it is not intended for use as a legal reference. Maine law governs an appellant's rights.

APPENDIX J

USACE MAINE GENERAL PERMIT
AUTHORIZATION LETTER

(This page left intentionally blank)



REPLY TO
ATTENTION OF

DEPARTMENT OF THE ARMY
NEW ENGLAND DISTRICT, CORPS OF ENGINEERS
696 VIRGINIA ROAD
CONCORD, MASSACHUSETTS 01742-2751

Regulatory Division
CENAE-RDC
File Number: NAE-2007-01211

Sara Zografos
Maine Turnpike Authority
2360 Congress Street
Portland, Maine 04102

Dear Ms. Zografos:

We have reviewed your application to fill approximately 58,086 s.f. of freshwater wetlands adjacent to the Maine Turnpike at York, Maine in order to construct a replacement for the existing deteriorated and deficient York Toll Plaza.

Based on the information you have provided, we have determined that the proposed activity, which includes a discharge of dredged or fill material into waters of the United States, including wetlands, will have only minimal individual or cumulative environmental impacts. Furthermore, we have determined that the proposed replacement facility represents the least environmentally damaging practicable alternative. Therefore, this work is authorized as a Category 2 activity under the enclosed Federal permit known as the Maine General Permit (GP). This work must be performed in accordance with the terms and conditions of the GP and also in compliance with any additional special condition(s).

You are responsible for complying with all of the GP's requirements. Please review the enclosed GP carefully, in particular the GP conditions beginning on Page 5, to familiarize yourself with its contents. You should ensure that whoever does the work fully understands the requirements and that a copy of the GP and this authorization letter are at the project site throughout the time the work is underway.

This authorization does not obviate the need to obtain other Federal, state, or local authorizations required by law, as listed on Page 3 of the GP. Performing work not specifically authorized by this determination or failing to comply with any special condition(s) provided above or all the terms and conditions of the GP may subject you to the enforcement provisions of our regulations.

This authorization becomes valid only after the Maine Department of Environmental Protection (DEP) issues or waives Water Quality Certification (WQC) as required under Section 401 of the Clean Water Act. In the event the DEP denies the 401 WQC, this determination becomes null and void. The address of the DEP regional office for your area is provided on Appendix D of the attached GP.

This authorization presumes that the work as described above and as shown on your plans noted is in waters of the U.S. Should you desire to appeal our jurisdiction, please submit a request for an approved jurisdictional determination in writing to this office.

This authorization expires on October 13, 2020. You must commence or have under contract to commence the work authorized herein by October 13, 2020 and complete the work by October 13, 2021. If you do not, you must contact this office to determine the need for further authorization before beginning or continuing the activity. We recommend you contact us *before* this permit expires to discuss a time extension or permit reissuance.

You must contact us immediately to discuss modification of this authorization if you change the plans or construction methods for work within our jurisdiction. This office must approve any changes before you undertake them.

We continually strive to improve our customer service. In order for us to better serve you, we would appreciate your completing our Customer Service Survey located at http://corpsmapu.usace.army.mil/cm_apex/f?p=regulatory_survey.

Please contact Jay Clement, of my staff, at our Manchester, Maine Project Office at (207) 623-8367 if you have any questions.

Sincerely,

Frank Del Giudice
Chief, Permits & Enforcement Branch
Regulatory Division

Enclosures



REPLY TO
ATTENTION OF

DEPARTMENT OF THE ARMY
NEW ENGLAND DISTRICT, CORPS OF ENGINEERS
696 VIRGINIA ROAD
CONCORD, MASSACHUSETTS 01742-2751

MAINE GENERAL PERMIT (GP)
AUTHORIZATION LETTER AND SCREENING SUMMARY

SARA ZOGRAFOS
MAINE TURNPIKE AUTHORITY
2360 CONGRESS STREET
PORTLAND, MAINE 04102

CORPS PERMIT # NAE-2007-01211
CORPS PGP ID# 16-517
STATE ID# NRPA

DESCRIPTION OF WORK:

Fill approximately 58,086 s.f. of freshwater wetlands adjacent to the Maine Turnpike, in the vicinity of Mile 8.8, at York, Maine in order to construct a replacement for the existing deteriorated and deficient York Toll Plaza. This work is shown on the attached plans entitled "PROJECT LOCATION MAP OF SOUTHERN MAINE TOLL PLAZA" in one sheet dated "3/18/2016", "YORK TOLL PLAZA" in two sheets dated "06/17/16", "YORK TOLL PLAZA" in 16 sheets revised "01/11/17", and "I-95 CROSS SECTIONS" in 38 sheets dated "08/16".

LAT/LONG COORDINATES : 43 179284° N -70.649289° W USGS QUAD: YORK HARBOR, ME

I. CORPS DETERMINATION:

Based on our review of the information you provided, we have determined that your project will have only minimal individual and cumulative impacts on waters and wetlands of the United States. Your work is therefore authorized by the U.S. Army Corps of Engineers under the enclosed Federal Permit, the Maine General Permit (GP). Accordingly, we do not plan to take any further action on this project.

You must perform the activity authorized herein in compliance with all the terms and conditions of the GP [including any attached Additional Conditions and any conditions placed on the State 401 Water Quality Certification including any required mitigation]. Please review the enclosed GP carefully, including the GP conditions beginning on page 5, to familiarize yourself with its contents. You are responsible for complying with all of the GP requirements; therefore you should be certain that whoever does the work fully understands all of the conditions. You may wish to discuss the conditions of this authorization with your contractor to ensure the contractor can accomplish the work in a manner that conforms to all requirements.

If you change the plans or construction methods for work within our jurisdiction, please contact us immediately to discuss modification of this authorization. This office must approve any changes before you undertake them.

Condition 37 of the GP (page 16) provides one year for completion of work that has commenced or is under contract to commence prior to the expiration of the GP on October 12, 2020. You will need to apply for reauthorization for any work within Corps jurisdiction that is not completed by October 12, 2021.

This authorization presumes the work shown on your plans noted above is in waters of the U.S. Should you desire to appeal our jurisdiction, please submit a request for an approved jurisdictional determination in writing to the undersigned.

No work may be started unless and until all other required local, State and Federal licenses and permits have been obtained. **This includes but is not limited to a Flood Hazard Development Permit issued by the town if necessary.**

II. STATE ACTIONS: PENDING [X], ISSUED[], DENIED [] DATE: _____

APPLICATION TYPE: PBR: _____, TIER 1: _____, TIER 2: _____, TIER 3: X, LUPC: _____, DMR LEASE: _____, NA: _____

III. FEDERAL ACTIONS:

JOINT PROCESSING MEETING: 11/10/16 LEVEL OF REVIEW: CATEGORY 1: _____ CATEGORY 2: X

AUTHORITY (Based on a review of plans and/or State/Federal applications): SEC 10 _____, 404 X 10/404 _____, 103 _____

EXCLUSIONS: The exclusionary criteria identified in the general permit do not apply to this project.

FEDERAL RESOURCE AGENCY OBJECTIONS: EPA NO, USF&WS NO, NMFS NO

If you have any questions on this matter, please contact my staff at 207-623-8367 at our Manchester, Maine Project Office. In order for us to better serve you, we would appreciate your completing our Customer Service Survey located at <http://per2.nwp.usace.army.mil/survey.html>

Jay L. Clement
JAY L. CLEMENT
SENIOR PROJECT MANAGER
MAINE PROJECT OFFICE

FRANK J. DEL GIUDICE 5-18-2017
FRANK J. DEL GIUDICE DATE
CHIEF, PERMITS & ENFORCEMENT BRANCH
REGULATORY DIVISION



**US Army Corps
of Engineers**®
New England District

**PLEASE NOTE THE FOLLOWING GENERAL CONDITIONS FOR
DEPARTMENT OF THE ARMY
GENERAL PERMIT
NO. NAE-2016-01211**

1. This authorization requires you to 1) notify us before beginning work so we may inspect the project, and 2) submit a Compliance Certification Form. You must complete and return the enclosed Work Start Notification Form(s) to this office at least two weeks before the anticipated starting date. You must complete and return the enclosed Compliance Certification Form within one month following the completion of the authorized work and any required mitigation (but not mitigation monitoring, which requires separate submittals).
2. The permittee shall assure that a copy of this permit is at the work site whenever work is being performed and that all personnel performing work at the site of the work authorized by this permit are fully aware of the terms and conditions of the permit. This permit, including its drawings and any appendices and other attachments, shall be made a part of any and all contracts and sub-contracts for work which affects areas of Corps of Engineers' jurisdiction at the site of the work authorized by this permit. This shall be done by including the entire permit in the specifications for the work. If the permit is issued after construction specifications but before receipt of bids or quotes, the entire permit shall be included as an addendum to the specifications. The term "entire permit" includes permit amendments. Although the permittee may assign various aspects of the work to different contractors or sub-contractors, all contractors and sub-contractors shall be obligated by contract to comply with all environmental protection provisions of the entire permit, and no contract or sub-contract shall require or allow unauthorized work in areas of Corps of Engineers jurisdiction.
3. Adequate sedimentation and erosion control devices, such as geotextile silt fences or other devices capable of filtering the fines involved, shall be installed and properly maintained to minimize impacts during construction. These devices must be removed upon completion of work and stabilization of disturbed areas. The sediment collected by these devices must also be removed and placed upland, in a manner that will prevent its later erosion and transport to a waterway or wetland.
4. All exposed soils resulting from the construction will be promptly seeded and mulched in order to achieve vegetative stabilization.
5. Mitigation shall consist of payment of \$56,589.60 to the Natural Resource Mitigation Fund. The completed ILF Project Data Worksheet which must be mailed with a cashiers check or bank draft, made out to "Treasurer, State of Maine", with the permit number noted on the check. The check and worksheet should be mailed to: ME DEP, Attn: ILF Program Administrator, State House Station 17, Augusta, ME 04333. **This authorization is not valid until the permittee provides the Corps with a copy of the check, with the permit number noted on the check.** The ILF amount is only valid for a period of one year from the date on the authorization letter. After that time, the project would need to be reevaluated and a new amount determined.

IN-LIEU-FEE (ILF) PROJECT DATA WORKSHEET

DEP Invoice # _____

[Note: Will be filled in by ILF Administrator at DEP]

Project name: Maine Turnpike Authority; York Toll Plaza Replacement

Applicant (s): Maine Turnpike Authority

DEP Permit #: L-27241-TG-A-N

Corps Permit #: NAE-2007-01211

ILF Contribution Amount \$281,649.01

[Note: Please attach a copy of the check]

Project address: Maine Turnpike; York, Maine

Biophysical region: Southern Maine; Gulf of Maine Coastal Lowland Subsection

Size of total impact subject to compensation: 58,086 s.f. (1.33 acres)

Resources Impacted: Refer to attached table

DEP Project manager: Green

Corps Project manager: Clement

Corps ILF Processing Procedure:

Within 3 days of final permit approval the Corps project manager MUST send via e-mail to the ILF Administrator at DEP with the following attachments:

1. A Microsoft word version of this completed ILF project worksheet including the resource impact table. Please make sure that you double check the information to make sure that the worksheet is accurate and reflects the actual impacts that are stated in the permit and the correct biophysical region.

[Note: The DEP Invoice # section of the worksheet should be left blank and will be filled in by the ILF Program Administrator.]

2. A copy of a location map for the project site. The map MUST be made in GIS and saved as a pdf and MUST include a call out box to physically locate the project site and enough reference information so that project site can be geo-located on the MNRCP GIS data layer.
3. A pdf copy of the Corps permit for the project.

Corps permittees MUST be instructed to send all required ILF payments to the attention of the ILF Administrator Maine Department of Environmental Protection, State House Station 17, Augusta, Maine 04333. All checks must have the ILF program routing # 014.06A.1776.14 on the memo line.

Resource(s) Impacted:

Resource Type: (Wetlands by NWI Type (PFO, PSS, M1, M2, E1, E2, etc), significant vernal pool (SVP), shorebird feeding & staging habitat (Shorebird), inland waterfowl & wading bird habitat (IWWH), tidal waterfowl & wading habitat (TWWH), and river, stream, or brook (RSB).

Wetland Functions & Values: Groundwater recharge/discharge (GWR); floodflow alterations (FF); fish & shellfish habitat (FSH); sediment toxicant retention (STR); nutrient removal (NR); production export (PE); sediment/shoreline stabilization (SS); wildlife habitat (WH); recreation (R); education/scientific value (ESV); uniqueness/heritage (UH); and visual quality/aesthetics (VQ).

Types of impacts: may include filling, dredging, vegetation conversion (e.g. forested to shrub/scrub), others.

Resource type (list all that apply)	Functions (for wetland impacts) (list all that apply, by resource type)	Type of Impact (by resource type)	Sq Feet Impacted (by resource type)
PFO1	WH, FF, STR, NR, GWR	Filling	54,022
PFO/SVP	WH, FF, STR, NR, GWR, PE	Filling	4,064
Total square feet impacted			58,086

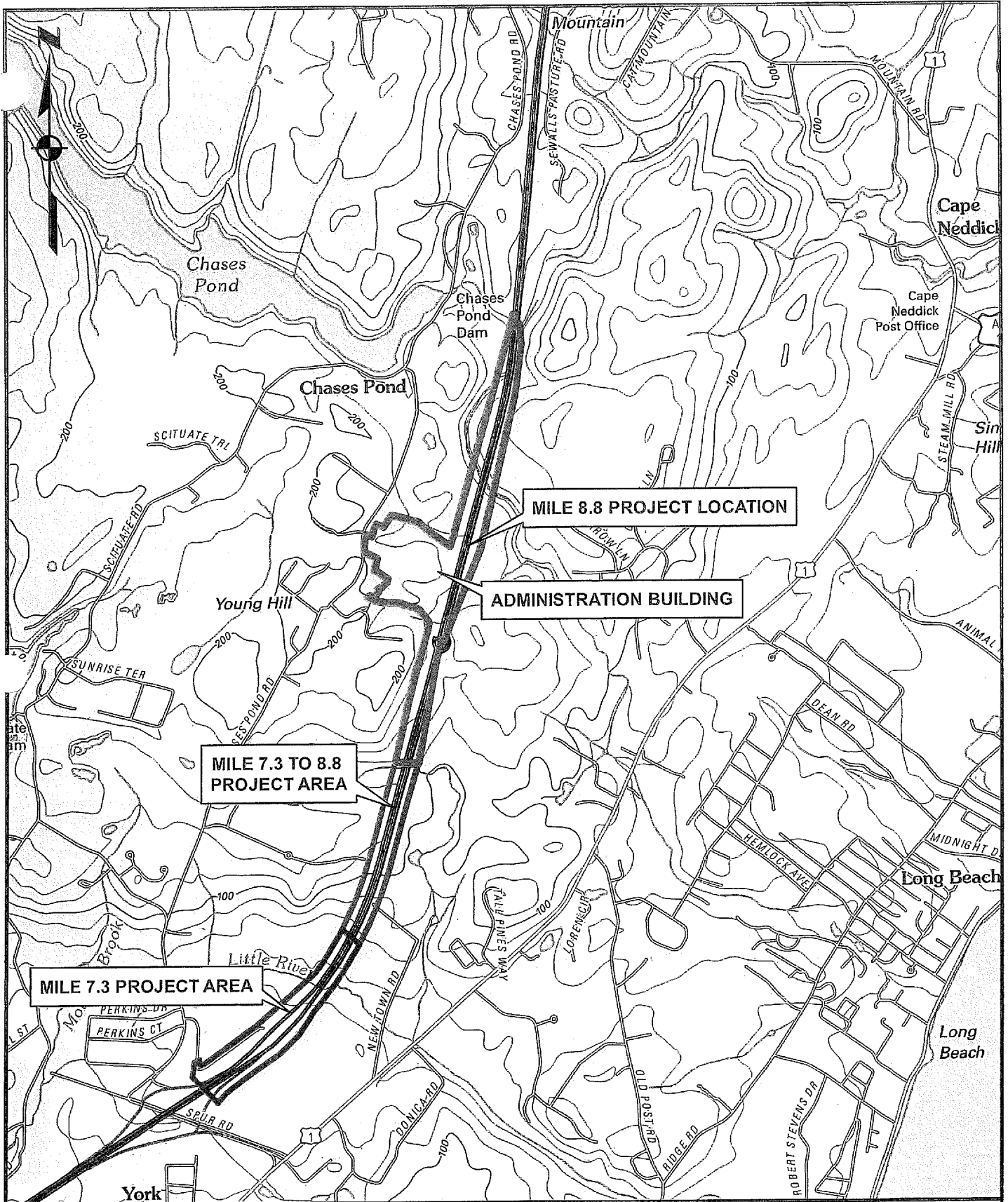

SEBAGO
TECHNICS

CIVIL ENGINEERING • SURVEYING • LANDSCAPE ARCHITECTURE

WWW.SEBAGOTECHNICS.COM

75 John Roberts Rd. - Suite 1A
South Portland, ME 04106
Tel. 207-260-2100

250 Goddard Rd. - Suite B
Lewiston, ME 04240
Tel. 207-783-5656

**PROJECT LOCATION MAP
OF SOUTHERN MAINE TOLL PLAZA**

LOCATION: MILE MARKER 8.8
YORK, MAINE

INFORMATION: 2011 USGS QUADRANGLE
(YORK HARBOR, MAINE)

SCALE: 1" = 2,000'

DATE: 3/18/2016

MAINE TURNPIKE

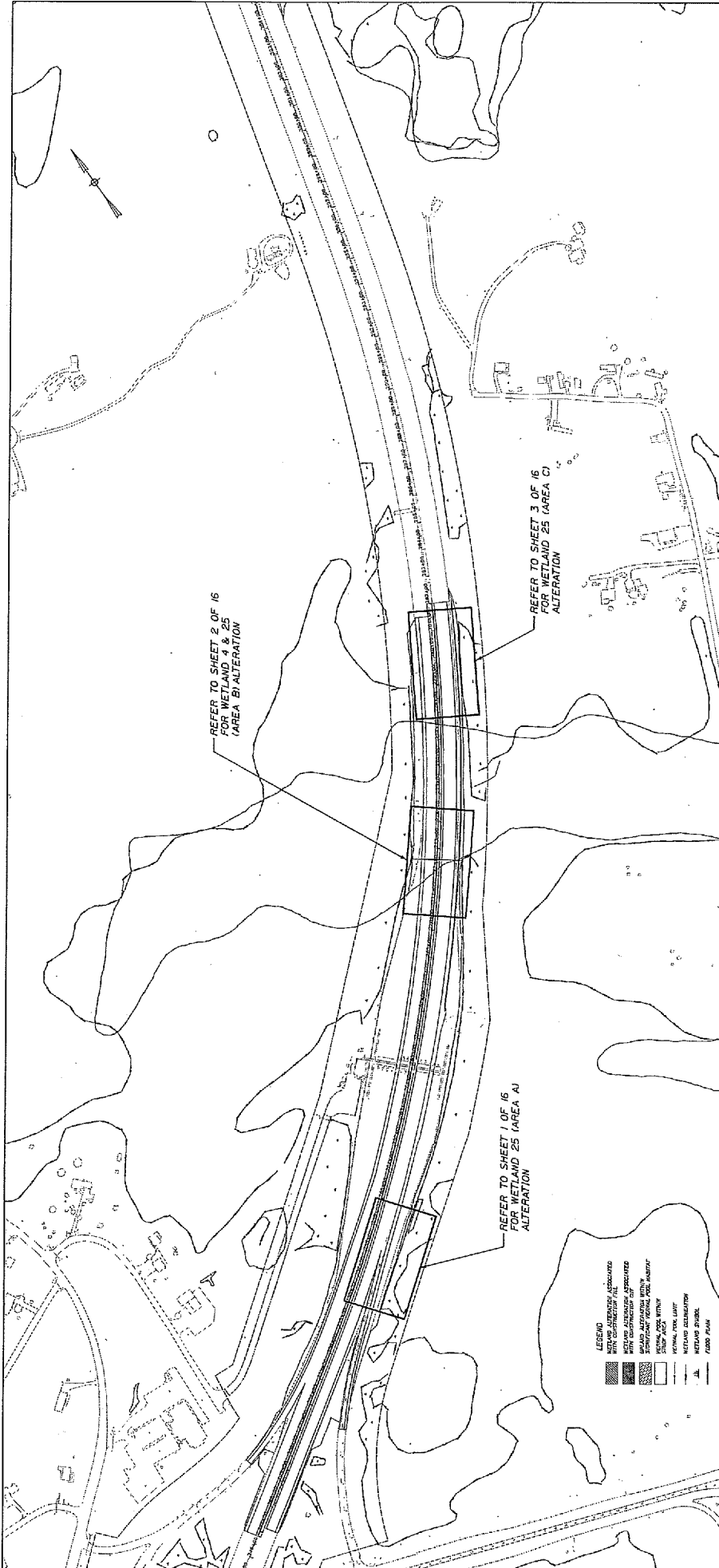

REFER TO SHEET 2 OF 16
FOR WETLAND 4 & 25
(AREA B) ALTERATION

REFER TO SHEET 1 OF 16
FOR WETLAND 25 (AREA A)
ALTERATION

REFER TO SHEET 3 OF 16
FOR WETLAND 25 (AREA C)
ALTERATION

- LEGEND**
- WETLAND ALTERATION ASSOCIATED WITH CONSTRUCTION FOOTPRINT
 - PLANNED ALTERATION WITH CONSTRUCTION FOOTPRINT
 - WETLAND ALTERATION WITH CONSTRUCTION FOOTPRINT
 - WETLAND ALTERATION WITH CONSTRUCTION FOOTPRINT
 - WETLAND ALTERATION WITH CONSTRUCTION FOOTPRINT
 - WETLAND ALTERATION WITH CONSTRUCTION FOOTPRINT
 - WETLAND ALTERATION WITH CONSTRUCTION FOOTPRINT
 - WETLAND ALTERATION WITH CONSTRUCTION FOOTPRINT
 - WETLAND ALTERATION WITH CONSTRUCTION FOOTPRINT

SEBAGO
INCORPORATED
1000 S. MAIN STREET
DUNDAS, MAINE 04930
TEL: (207) 533-3300
WWW.SEBAGO.COM

Contract No. 2010-01-001
Project No. 2010-01-001
Sheet No. 157
Scale: 1" = 40'

DATE: 10/17/10
BY: JTB

THE GOLD STAR
MEMORIAL HIGHWAY
WETLAND ALTERATION/COMPENSATION PLAN

CONTRACT: 2010-01-001
SHEET NUMBER: 157

YORK TOLL PLAZA
WETLAND ALTERATION/COMPENSATION PLAN

CONTRACT: 2010-01-001
SHEET NUMBER: 157

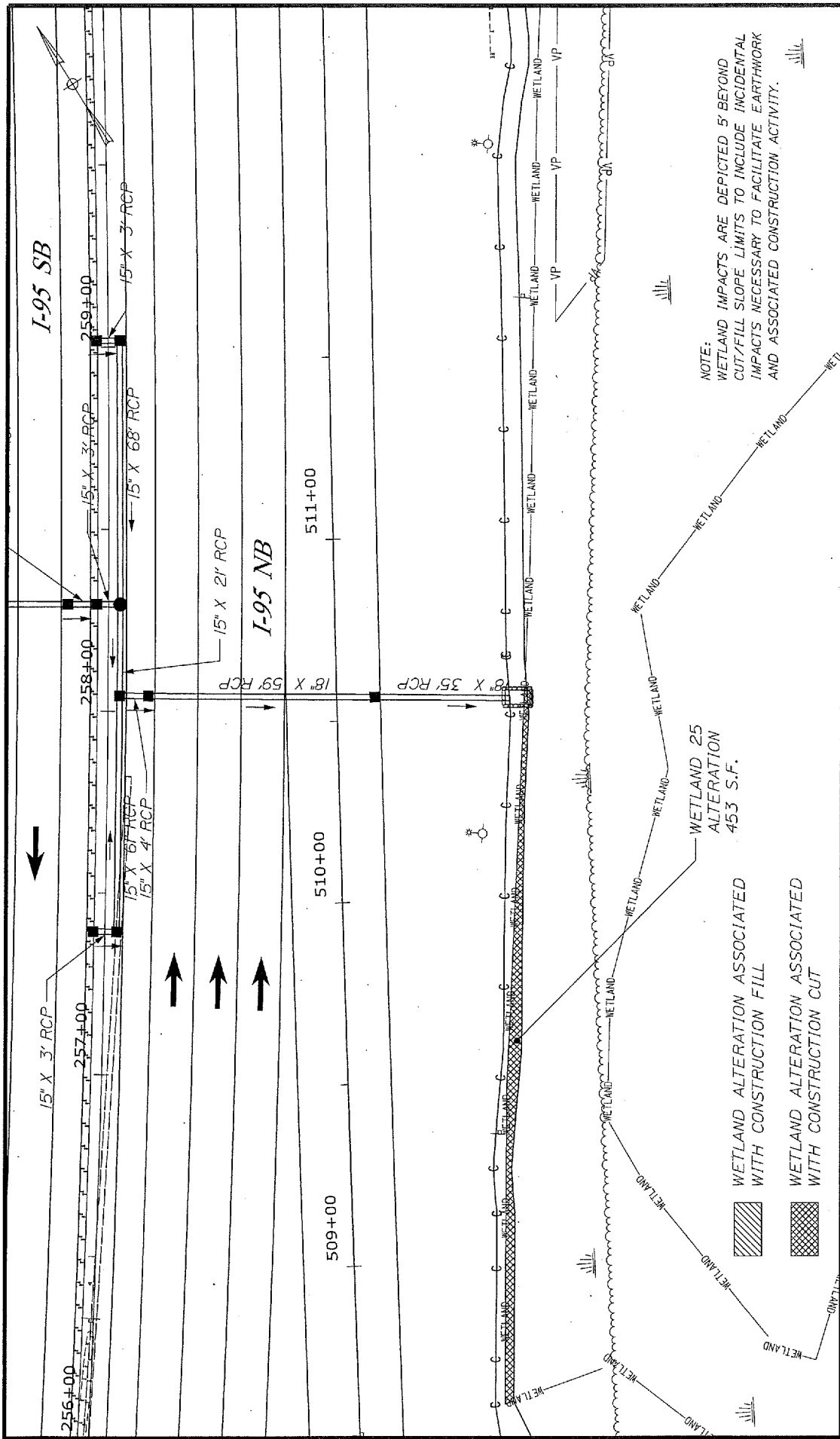

NOTE:
WETLAND IMPACTS ARE DEPICTED 5' BEYOND CUT/FILL SLOPE LIMITS TO INCLUDE INCIDENTAL IMPACTS NECESSARY TO FACILITATE EARTHWORK AND ASSOCIATED CONSTRUCTION ACTIVITY.

WETLAND 25 ALTERATION 453 S.F.

WETLAND ALTERATION ASSOCIATED WITH CONSTRUCTION FILL
 WETLAND ALTERATION ASSOCIATED WITH CONSTRUCTION CUT

		THE GOLD STAR MEMORIAL HIGHWAY	YORK TOLL PLAZA
SEBAGO TECHNICS 75 JOHN ROBERTS ROAD, SUITE 100 SOUTH PORTLAND, ME 04106 TEL (207) 200-2100		WETLAND 25 ALTERATION SHEET NUMBER: WA-A 1 OF 16	
MTA PROJECT MANAGER: R. NORWOOD CONTRACT: 2017.09			
SEBAGO TECHNICS WWW.SEBAGOTECHNICS.COM		DESIGNED BY: E. DUBOIS C. DUBOIS J. DUBOIS M. DUBOIS REV. PER USAGE COMMENT: SCAM 03/17/17 10/17/17	
DESIGNED BY: E. DUBOIS C. DUBOIS J. DUBOIS M. DUBOIS REV. PER USAGE COMMENT: SCAM 03/17/17 10/17/17		Scale: 1" = 25' 0 12.5 25' Scale of Feet	

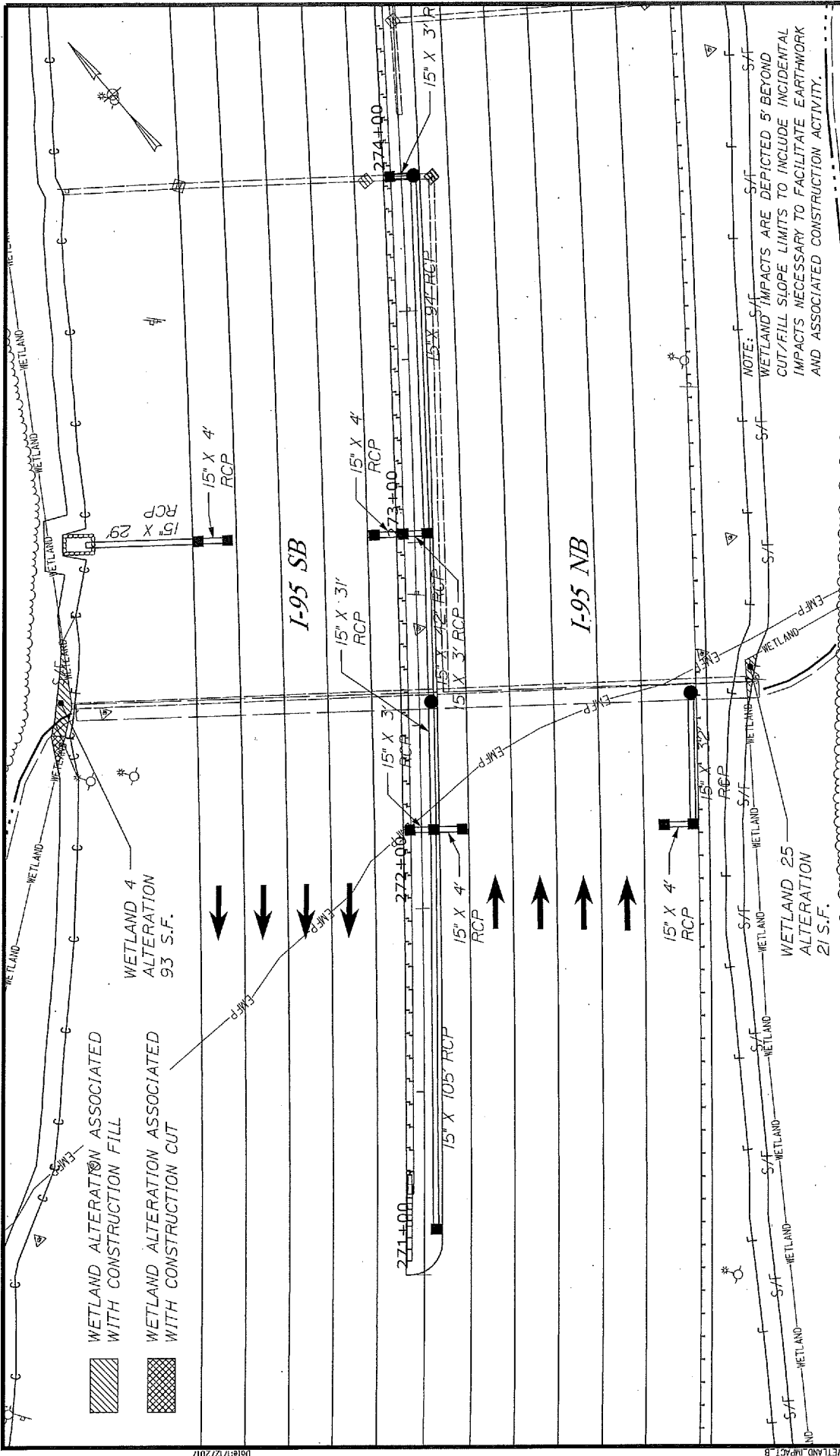

YORK TOLL PLAZA

WETLAND 4 & 25 ALTERATION

SEBAGO TECHNICS
 75 JOHN ROBERTS ROAD,
 SUITE 1A
 SOUTH PORTLAND, ME 04106
 TEL (207) 200-2100

CONTRACT: 2017.09
 SHEET NUMBER: WA-B
 2 OF 16

THE GOLD STAR MEMORIAL HIGHWAY

MTA PROJECT MANAGER: R. NORWOOD

SEBAGO TECHNICS
 WWW.SEAGOTECHNICS.COM

DESIGNED BY: [Signature]

No.	Revision	By	Date
1	PROGRESS SUBMITTAL	OAM	09/20/16
2	MISCELLANEOUS REVISIONS	OAM	09/07/16
3	UPDATED MAPS	OAM	09/16/16
4	REV. PER USAGE COMMENT	OAM	01/11/17

By	Date	By	Date
DLR	1/11/17	Checked	OAM
DLR	1/11/17	In Charge of	--/--

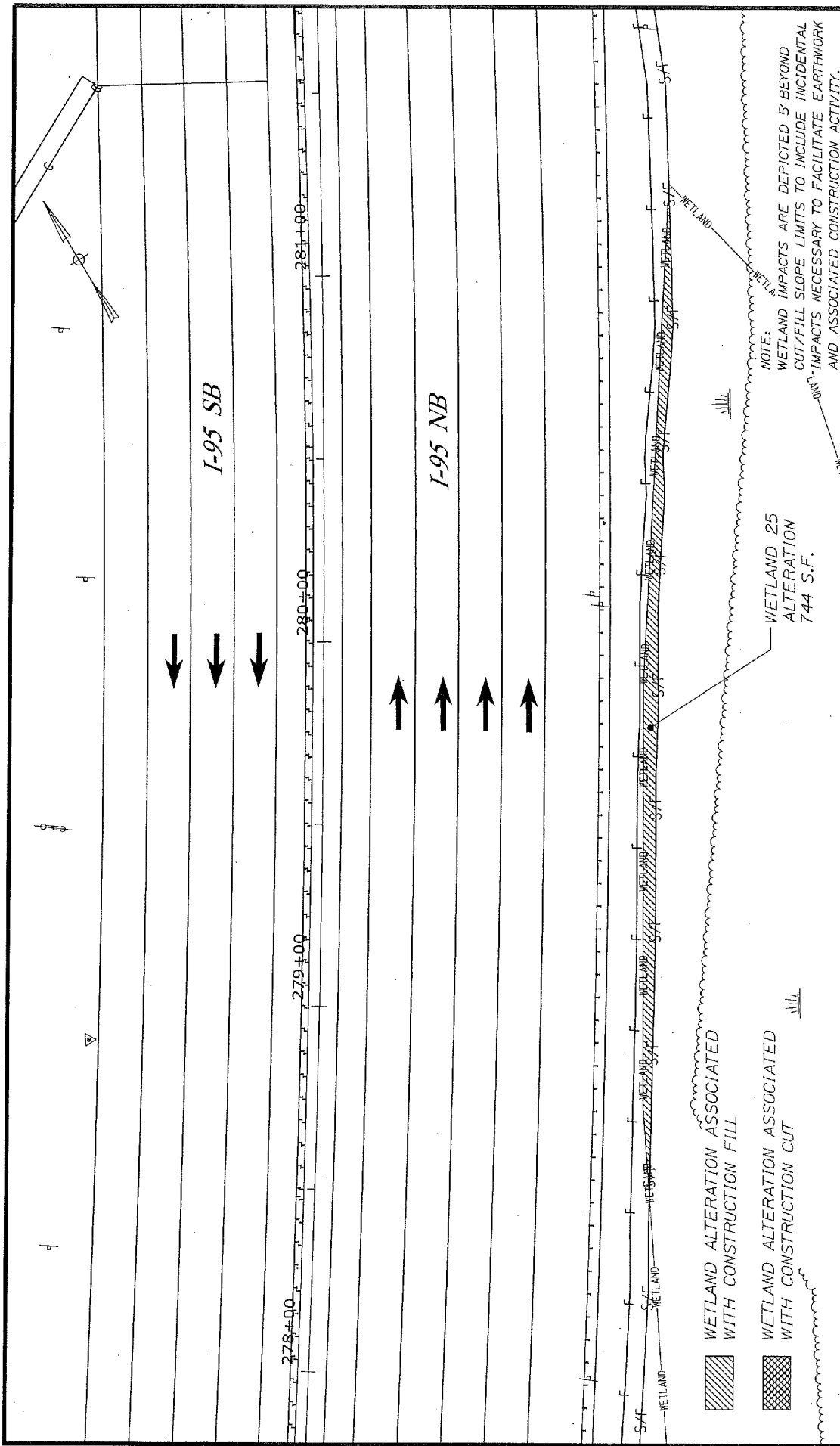

		THE GOLD STAR MEMORIAL HIGHWAY		YORK TOLL PLAZA	
SEBAGO TECHNICS 75 JOHN ROBERTS ROAD, SOUTH POLK, IOWA 50416 TEL (507) 200-2100		WETLAND 25 ALTERATION 744 S.F.		WETLAND 25 ALTERATION	
Designed by:		Scale: 1/2" = 25'		CONTRACT: 2017.09	
PROJECT MANAGER: S. SAWYER, P.E.		CONSULTANT PROJECT MANAGER: S. SAWYER, P.E.		SHEET NUMBER: WA-C	
By: [Signature] Date: 1/17/17		Checked: [Signature] Date: 1/17/17		3 OF 16	
By: [Signature] Date: 09/17/16		Checked: [Signature] Date: 09/17/16		3 OF 16	
By: [Signature] Date: 07/17/17		Checked: [Signature] Date: 07/17/17		3 OF 16	

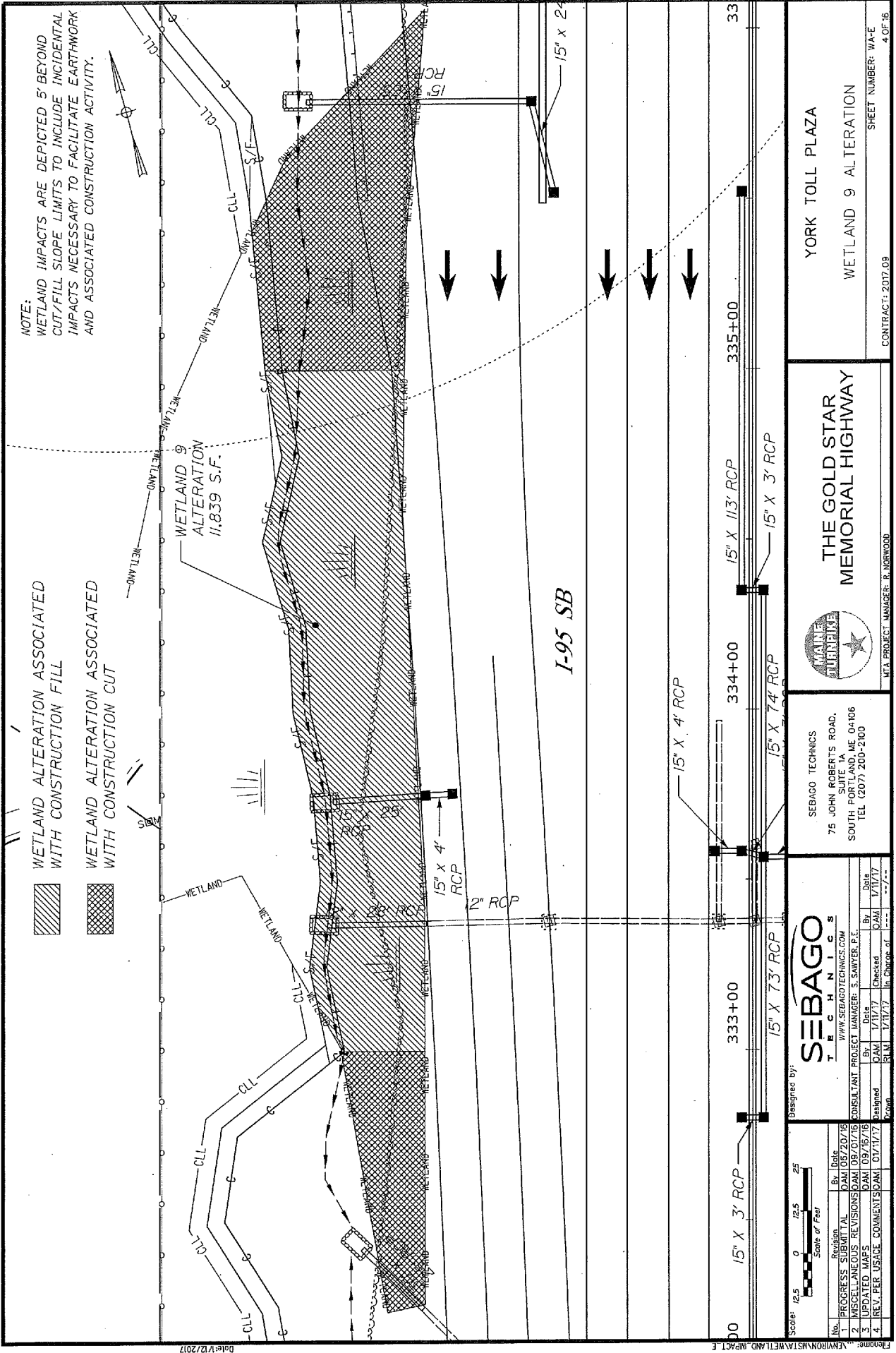

NOTE:
 WETLAND IMPACTS ARE DEPICTED 5' BEYOND
 CUT/FILL SLOPE LIMITS TO INCLUDE INCIDENTAL
 IMPACTS NECESSARY TO FACILITATE EARTHWORK
 AND ASSOCIATED CONSTRUCTION ACTIVITY.

WETLAND ALTERATION ASSOCIATED
 WITH CONSTRUCTION FILL
 WETLAND ALTERATION ASSOCIATED
 WITH CONSTRUCTION CUT

YORK TOLL PLAZA
 WETLAND 9 ALTERATION

THE GOLD STAR
 MEMORIAL HIGHWAY



SEBAGO TECHNICS
 75 JOHN ROBERTS ROAD,
 SUITE 1A
 SOUTH PORTLAND, ME 04106
 TEL (207) 200-2100

SEBAGO
 TECHNICS
 WWW.SEBAGOTECHNICS.COM

By	Date	By	Date
RAM	1/11/17	RAM	1/11/17
Checked	1/11/17	Checked	1/11/17
Assigned	01/11/17	Assigned	01/11/17
Drawn	1/11/17	Drawn	1/11/17

No.	Revision	By	Date
1	PROGRESS SUBMITTAL	QAM	08/20/16
2	MISCELLANEOUS REVISIONS	QAM	09/01/16
3	UPDATED MAPS	QAM	09/16/16
4	REV. PER USAGE COMMENTS	QAM	01/11/17

Scale: 12.5 0 12.5 25
 Scale of Feet

FORMS: ENVIRONMENTAL WETLAND IMPACT STATEMENT
 CONTRACT: 2017-09
 SHEET NUMBER: WA-E
 4 OF 16

1339+00

1340+00

1341+00

1342+00

I-95 NB

NOTE:

WETLAND IMPACTS ARE DEPICTED 5' BEYOND CUT/FILL SLOPE LIMITS TO INCLUDE INCIDENTAL IMPACTS NECESSARY TO FACILITATE EARTHWORK AND ASSOCIATED CONSTRUCTION ACTIVITY.

WETLAND 18 ALTERATION 9.773 S.F.

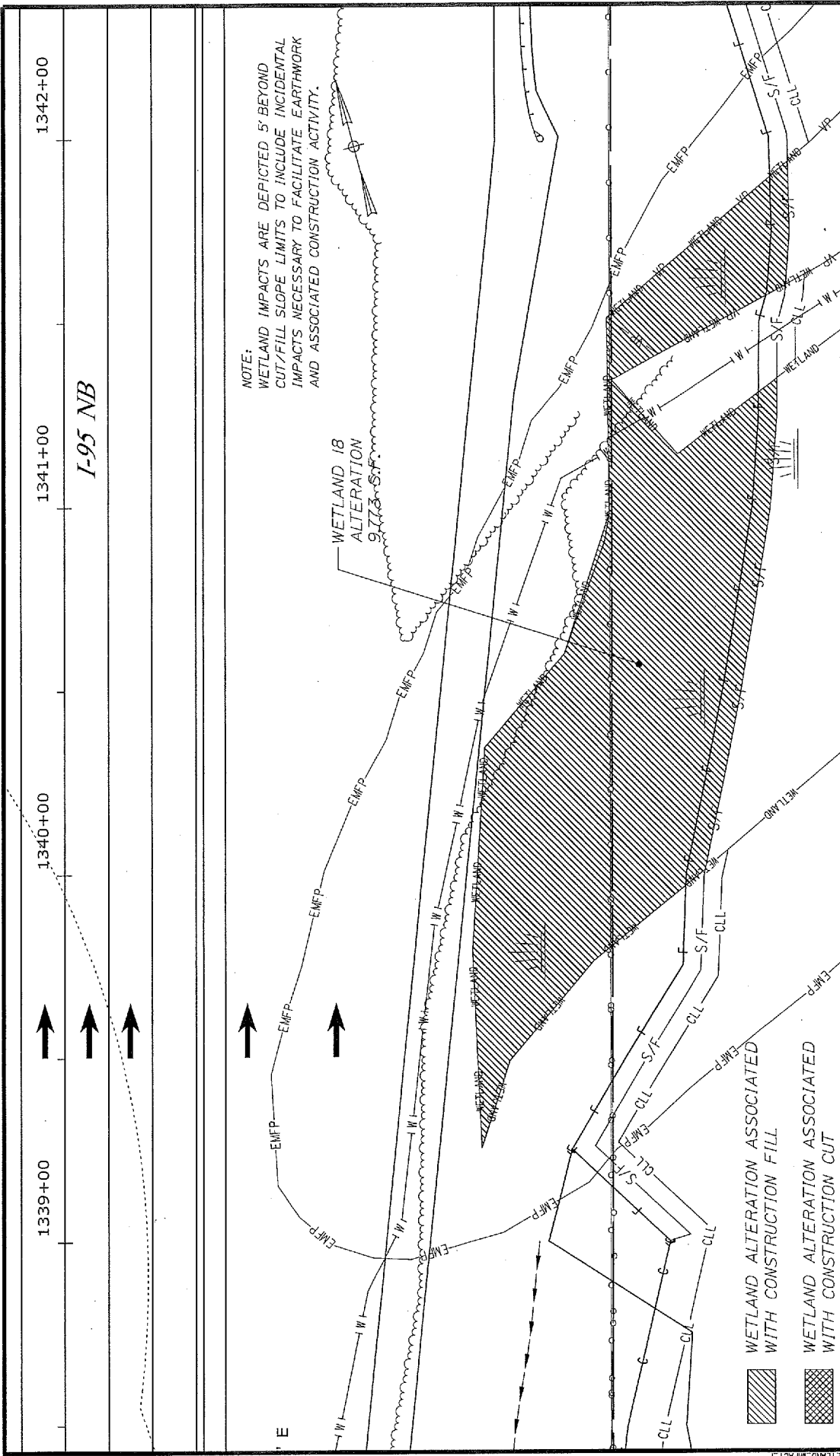

WETLAND ALTERATION ASSOCIATED WITH CONSTRUCTION FILL

WETLAND ALTERATION ASSOCIATED WITH CONSTRUCTION CUT

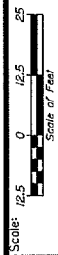

Designed by:

SEBAGO
TECHNICALS
WWW.SEAGOTECHNICALS.COM

1	PROGRESS SUBMITTAL	By: DAK	01/17/17
2	DESIGN REVISIONS	By: S. SAWYER, P.E.	01/17/17
3	REVISIONS	By: DAK	01/17/17
4	REV. PER USAGE COMMENTS	By: DAK	01/17/17

SEBAGO TECHNICS
75 JOHN ROBERTS ROAD,
SUITE 1A
SOUTH PORTLAND, ME 04106
TEL (207) 200-2100



THE GOLD STAR
MEMORIAL HIGHWAY

YORK TOLL PLAZA

WETLAND 18 ALTERATION

CONTRACT: 2017.09
SHEET NUMBER: WA-F
5 OF 16

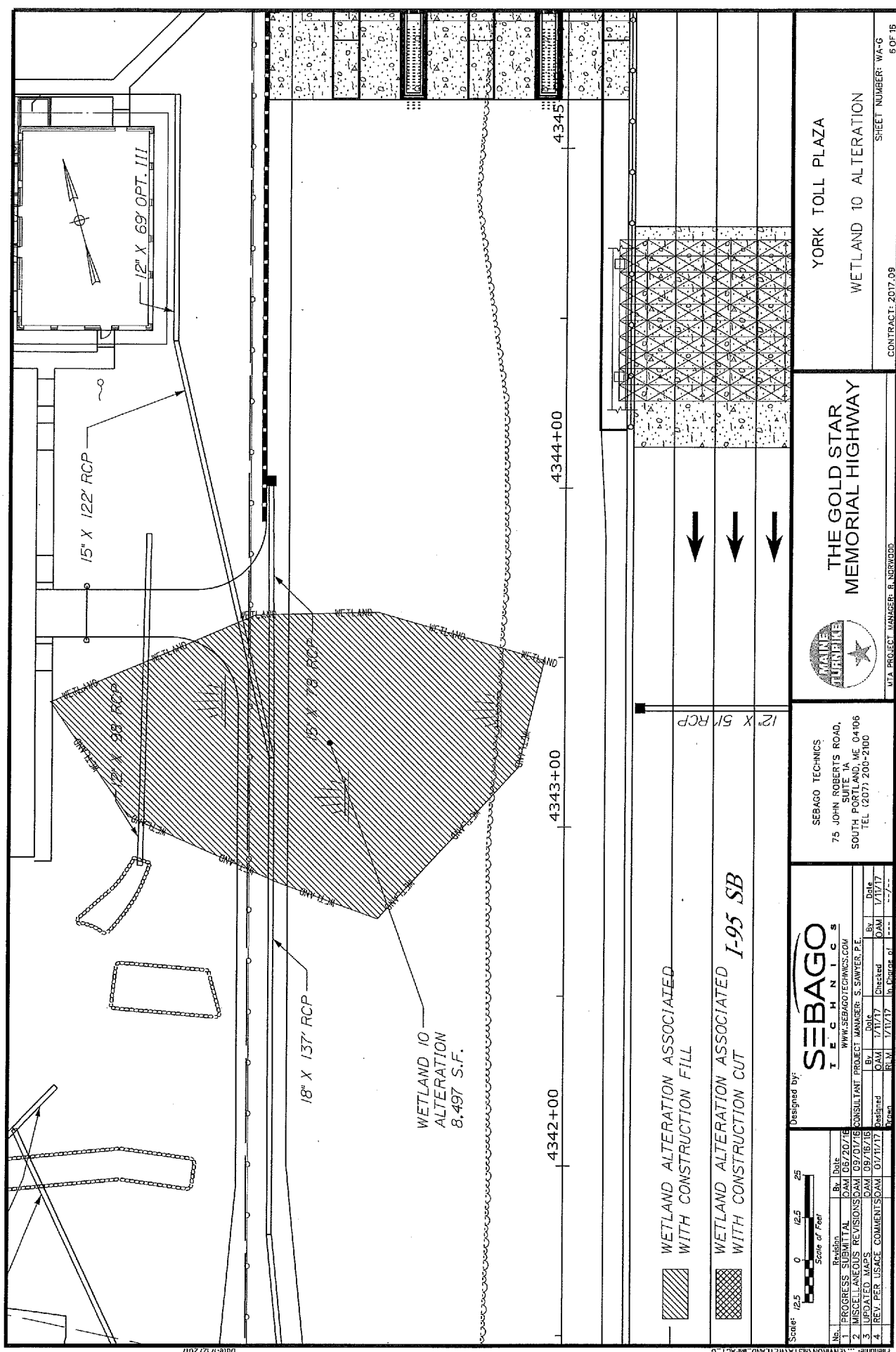

SEBAGO TECHNICS
 75 JOHN ROBERTS ROAD,
 SUITE 1A
 SOUTH PORTLAND, ME 04106
 TEL (207) 200-2100

SEBAGO
 TECHNICS
 WWW.SEBAGOTECHNICS.COM

Revision	By	Date
1	OAM	05/20/16
2	OAM	09/07/16
3	OAM	09/16/16
4	OAM	07/17/17

Project Manager: S. Sawyer, P.E.
 Checked: []
 In Charge: []
 Date: 1/17/17
 Scale: 1/2" = 25' - 0' - 12.5'

YORK TOLL PLAZA
 WETLAND 10 ALTERATION

CONTRACT: 2017.09
 SHEET NUMBER: WA-6
 6 OF 15

Filename: \\ENVRON\STAFF\WETLAND_R\ACT.0 Date: 1/12/2017

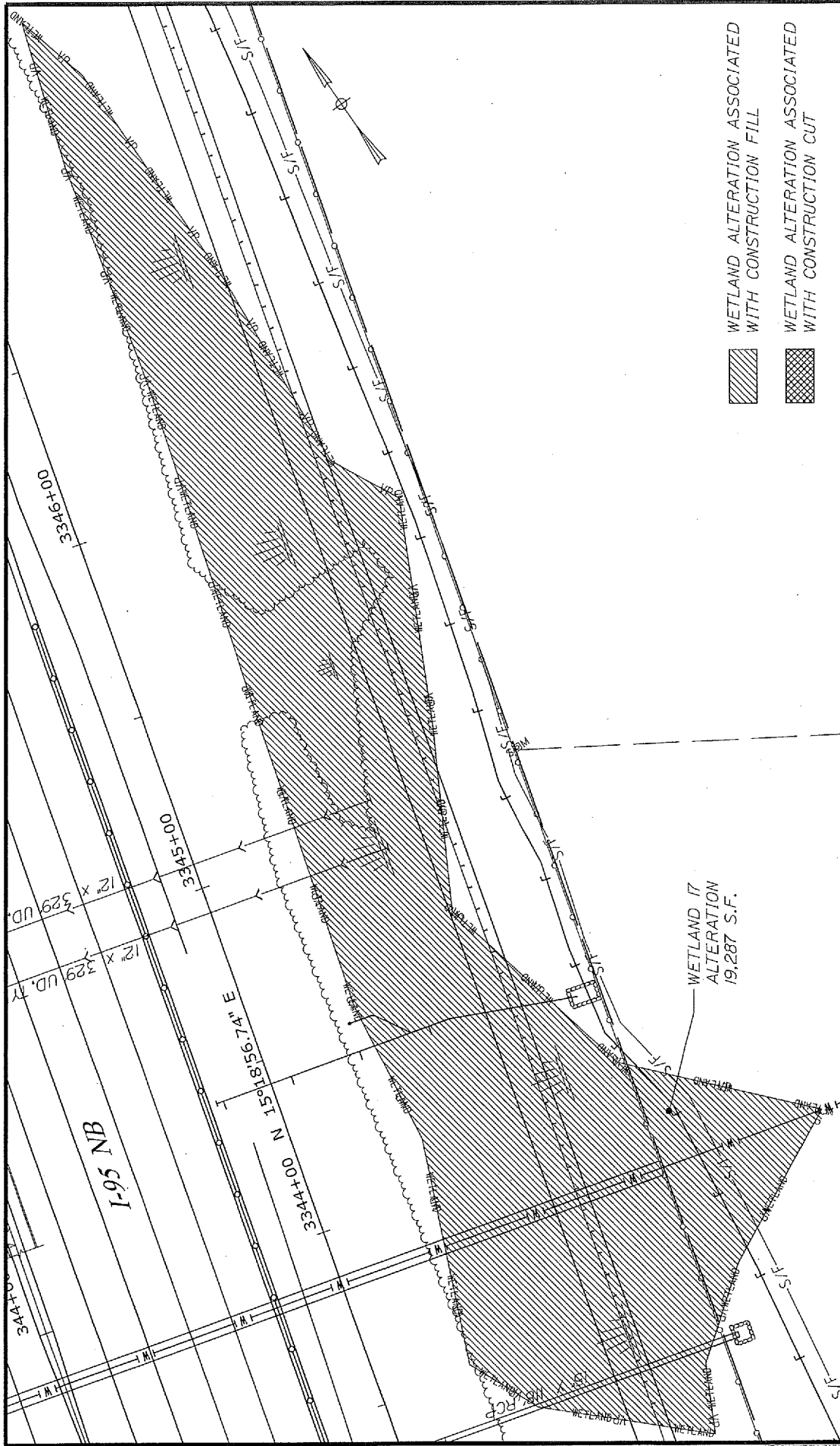

WETLAND ALTERATION ASSOCIATED WITH CONSTRUCTION FILL

WETLAND ALTERATION ASSOCIATED WITH CONSTRUCTION CUT

YORK TOLL PLAZA

WETLAND 17 ALTERATION

THE GOLD STAR MEMORIAL HIGHWAY



SEBAGO TECHNICS
75 JOHN ROBERTS ROAD,
SUITE 1A
SOUTH PORTLAND, ME 04106
TEL (207) 200-2100

SEBAGO TECHNICS
WWW.SEBAGO-TECHNICS.COM
CONSULTANT PROJECT MANAGER: S. SAWYER, P.E.

No.	Revision	By	Date	Checked	In Charge
1	PROGRESS SUBMITTAL	OAM	08/20/16		
2	MISCELLANEOUS REVISIONS	OAM	09/01/16		
3	UPDATED MAPS	OAM	09/16/16		
4	REV. PER USAGE COMMENTS	OAM	01/11/17		

Designed by: [Signature]

No.	Revision	By	Date	Checked	In Charge
1	PROGRESS SUBMITTAL	OAM	08/20/16		
2	MISCELLANEOUS REVISIONS	OAM	09/01/16		
3	UPDATED MAPS	OAM	09/16/16		
4	REV. PER USAGE COMMENTS	OAM	01/11/17		

Scale: 1/2.5 0 12.5 25
Scale of Feet

CONTRACT: 2017.09
SHEET NUMBER: WA-1
7 OF 16

M/A PROJECT MANAGER: R. NORWOOD

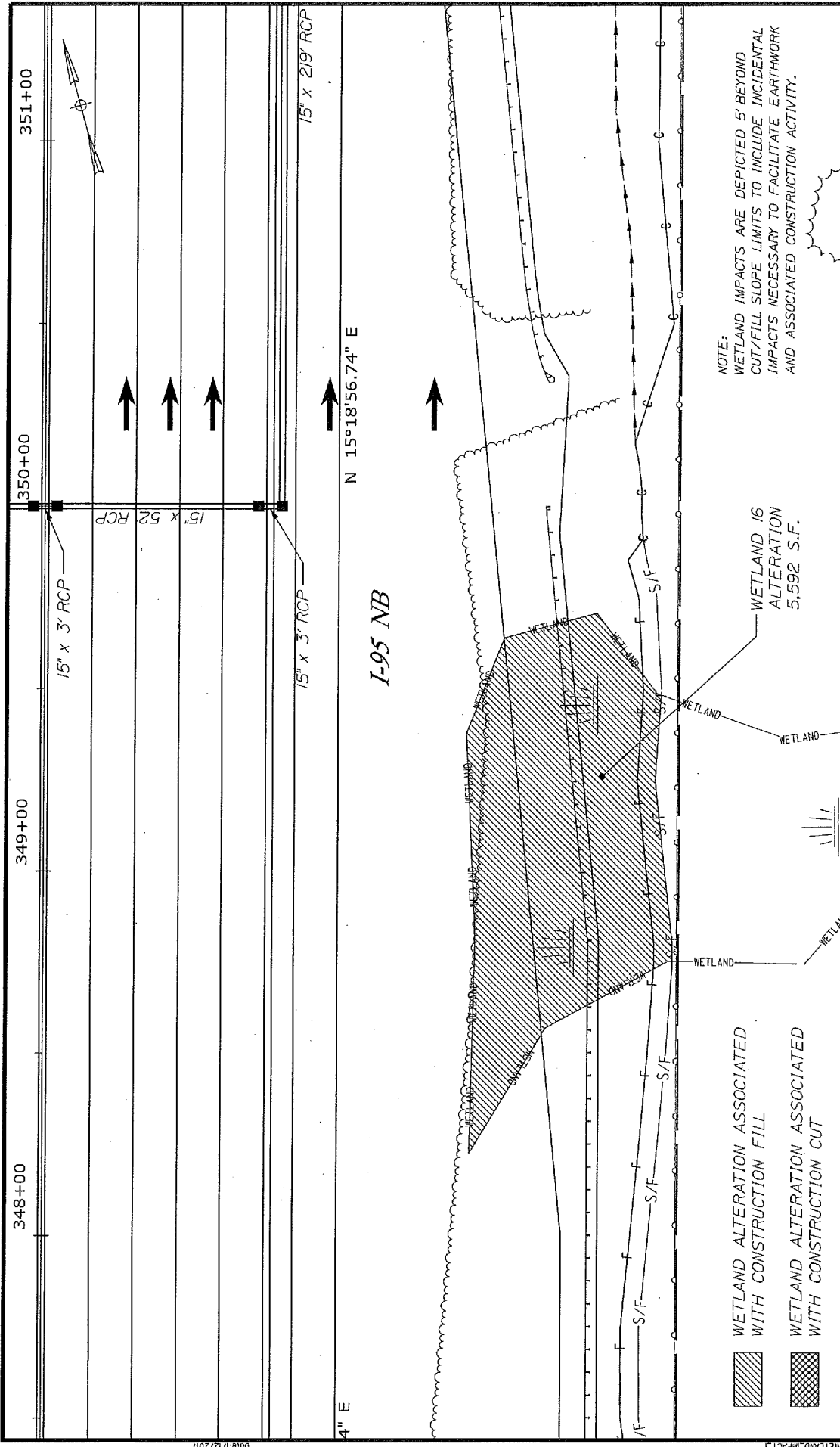

Scale: 1/2.5 0 12.5 25
 Scale of Feet

No.	Revision	By	Date
1	PROGRESS SUBMITTAL	RAM	08/20/16
2	MISCELLANEOUS REVISIONS	RAM	08/18/16
3	UPDATED MARS	RAM	08/18/16
4	REV. PER. USAGE COMMENTS	RAM	01/17/17

Designed by: **SEBAGO TECHNICS**
 WWW.SEAGOTECHNICS.COM
 CONSULTANT PROJECT MANAGER: S. SWAYER, P.E.
 Checked: RAM 1/17/17
 Designated: RAM 1/17/17
 In Charge of: RAM 1/17/17

SEBAGO TECHNICS
 75 JOHN ROBERTS ROAD,
 SOUTH PORTLAND, ME 04106
 TEL. (207) 200-2100

THE GOLD STAR MEMORIAL HIGHWAY

YORK TOLL PLAZA
 WETLAND 16 ALTERATION

NOTE:
 WETLAND IMPACTS ARE DEPICTED 5' BEYOND CUT/FILL SLOPE LIMITS TO INCLUDE INCIDENTAL IMPACTS NECESSARY TO FACILITATE EARTHWORK AND ASSOCIATED CONSTRUCTION ACTIVITY.

WETLAND ALTERATION ASSOCIATED WITH CONSTRUCTION FILL
 WETLAND ALTERATION ASSOCIATED WITH CONSTRUCTION CUT

WETLAND

WETLAND 16 ALTERATION 5,592 S.F.

DATE: 1/12/2017

FILE: ENVRONSTA\WETLAND_IMPACT1

CONTRACT: 2017.09
 SHEET NUMBER: WA-1
 BOF-16

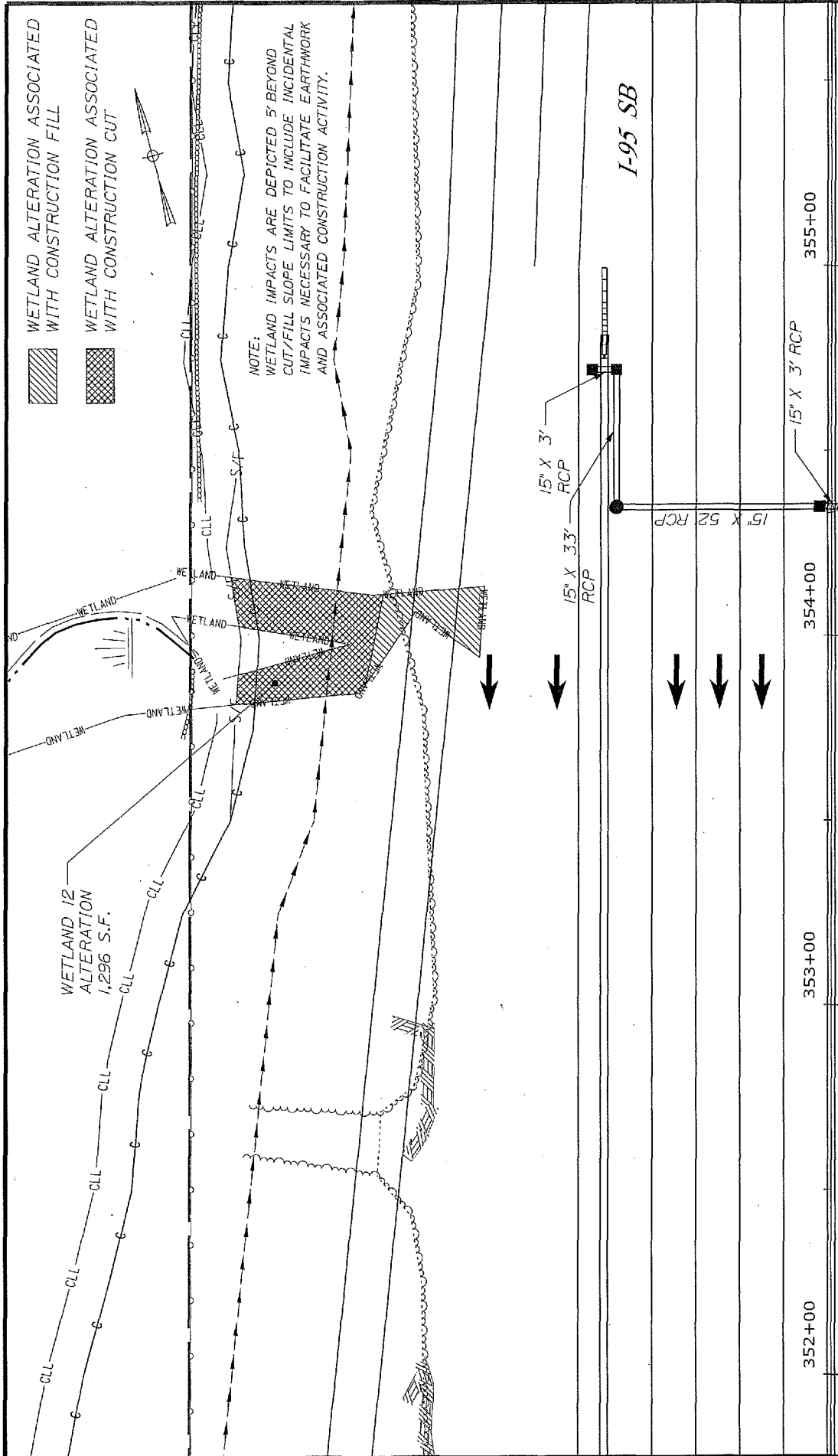

WETLAND ALTERATION ASSOCIATED WITH CONSTRUCTION FILL

WETLAND ALTERATION ASSOCIATED WITH CONSTRUCTION CUT

NOTE:
WETLAND IMPACTS ARE DEPICTED 5' BEYOND CUT/FILL SLOPE LIMITS TO INCLUDE INCIDENTAL IMPACTS NECESSARY TO FACILITATE EARTHWORK AND ASSOCIATED CONSTRUCTION ACTIVITY.

WETLAND 12 ALTERATION 1,296 S.F.

I-95 SB

355+00

354+00

353+00

352+00

15" X 3' RCP

15" X 3' RCP

15" X 3.3' RCP

15" X 52 RCP



No.	Revision	By	Date
1	PROGRESS SUBMITTAL	DAM	06/20/16
2	UPDATING REVISIONS	DAM	09/16/16
3	REV. PER USACE COMMENTS	DAM	01/18/17
4	REV. PER USACE COMMENTS	DAM	01/18/17

Designed by:

SEBAGO
TECHNICALS

Rev.	Checked	By	Date
1	Checked	DAM	1/18/17
2	Checked	DAM	1/18/17
3	Checked	DAM	1/18/17
4	Checked	DAM	1/18/17

SEBAGO TECHNICS
75 JOHN ROBERTS ROAD,
SUITE 1A
SOUTH PORTLAND, ME 04106
TEL (207) 200-2100



THE GOLD STAR
MEMORIAL HIGHWAY

YORK TOLL PLAZA

WETLAND 12 ALTERATION

CONTRACT: 2017.09
SHEET NUMBER: WA-J
9 OF 16

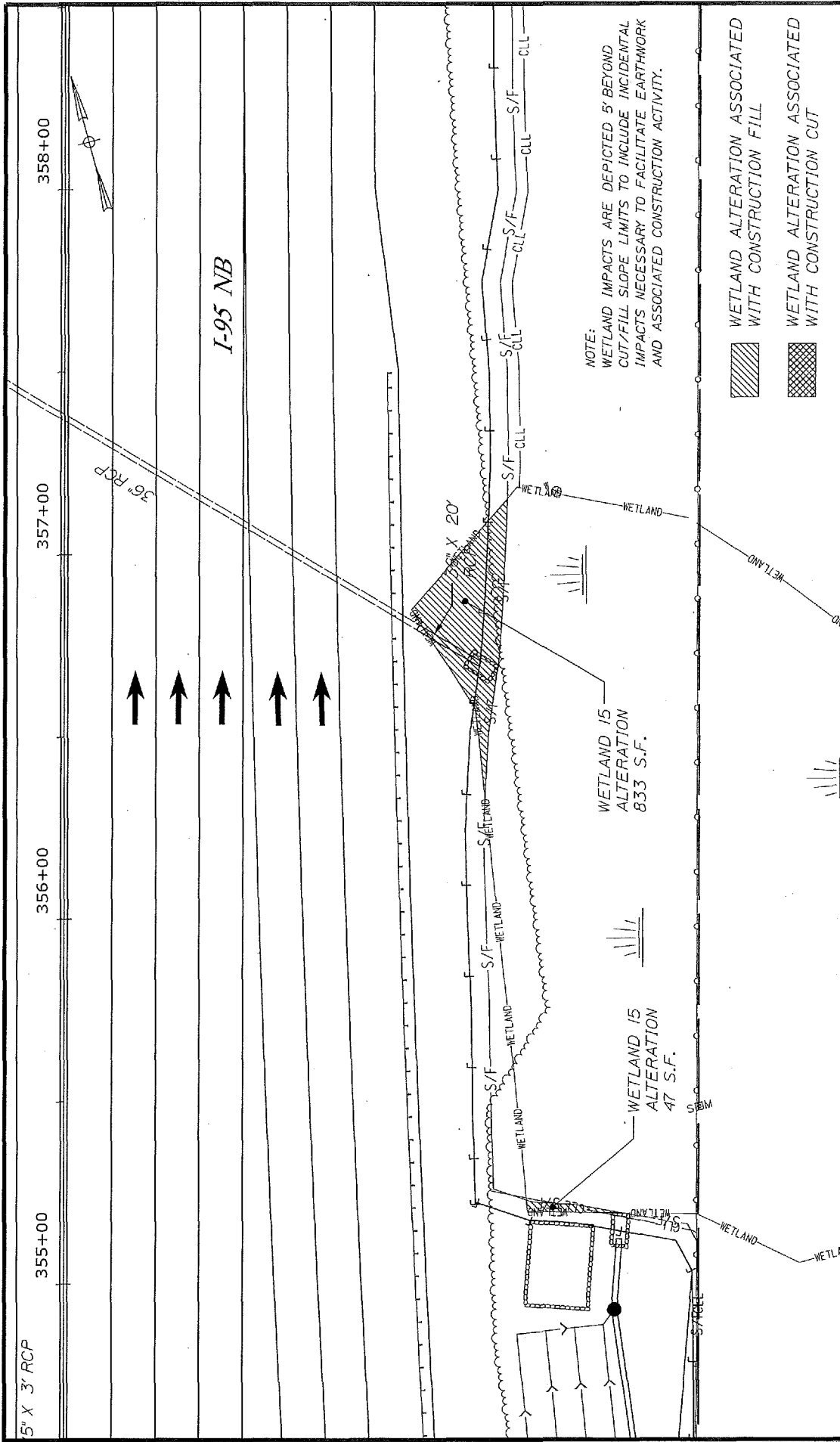

NOTE:
 WETLAND IMPACTS ARE DEPICTED 5' BEYOND
 CUT/FILL SLOPE LIMITS TO INCLUDE INCIDENTAL
 IMPACTS NECESSARY TO FACILITATE EARTHWORK
 AND ASSOCIATED CONSTRUCTION ACTIVITY.

- WETLAND ALTERATION ASSOCIATED WITH CONSTRUCTION FILL
- WETLAND ALTERATION ASSOCIATED WITH CONSTRUCTION CUT

	THE GOLD STAR MEMORIAL HIGHWAY	YORK TOLL PLAZA WETLAND 15 ALTERATION
SEBAGO TECHNICS 75 JOHN ROBERTS ROAD, SUITE 1A SOUTH PORTLAND, ME 04106 TEL (207) 200-2100	SEBAGO TECHNICS <small>WWW.SEBAGOTECHNICS.COM</small> CONSULTANT PROJECT MANAGER: S. SWINER, P.E. By: <u>CSM</u> Date: 1/11/17 Checked: <u>OAM</u> Date: 1/11/17 Design: <u>BLM</u> Date: 1/11/17 Drawn: <u>---</u>	CONTRACT: 2017.09 SHEET NUMBER: WA-K 10 OF 16

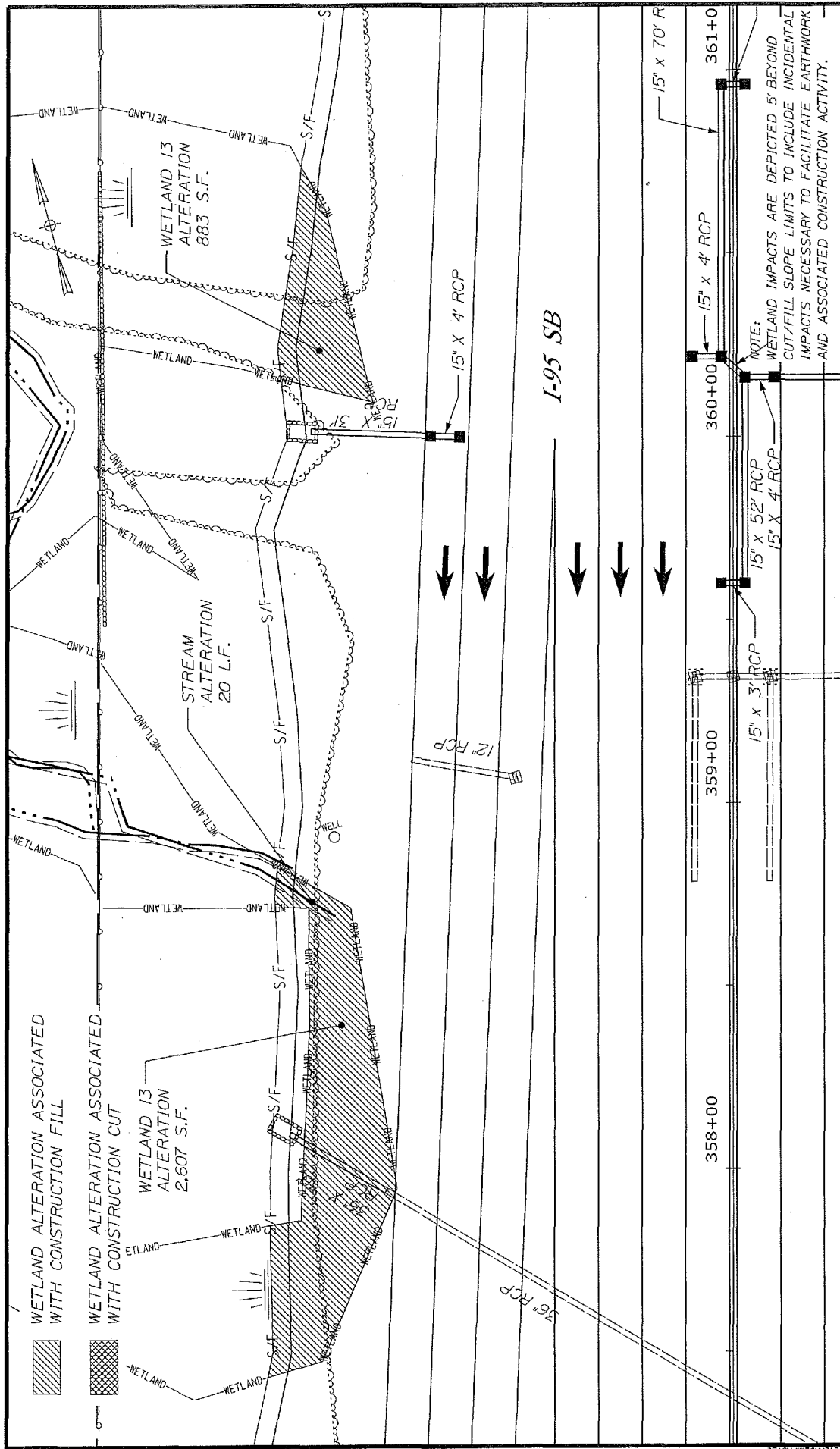

Scale: 1/2" = 25' 25
Scale of Plot:

No.	Revision	By	Date
1	PROGRESS SUBMITTAL	DAM	06/20/18
2	MISCELLANEOUS REVISIONS	DAM	09/07/18
3	UPDATED MAPS	DAM	09/16/18
4	REV. PER USAGE COMMENTS	DAM	07/11/17

Designated by: _____
 Checked by: _____
 Date: 1/11/17

SEBAGO TECHNICS
 T E C H N I C S
 WWW.SEAGOTECHNICS.COM
 PROJECT MANAGER: S. SHAWER, P.E.

SEBAGO TECHNICS
 75 JOHN ROBERTS ROAD,
 SOUTH PORTER, IA ME 04106
 TEL (207) 200-2100

THE GOLD STAR MEMORIAL HIGHWAY

YORK TOLL PLAZA
 WETLAND 13 ALTERATION

NOTE: WETLAND IMPACTS ARE DEPICTED 5' BEYOND CUT/FILL SLOPE LIMITS TO INCLUDE INCIDENTAL IMPACTS NECESSARY TO FACILITATE EARTHWORK AND ASSOCIATED CONSTRUCTION ACTIVITY.

DATE: 1/12/2017
 PROJECT: WETLAND IMPACT 1
 SHEET NUMBER: WA-1
 11 OF 18

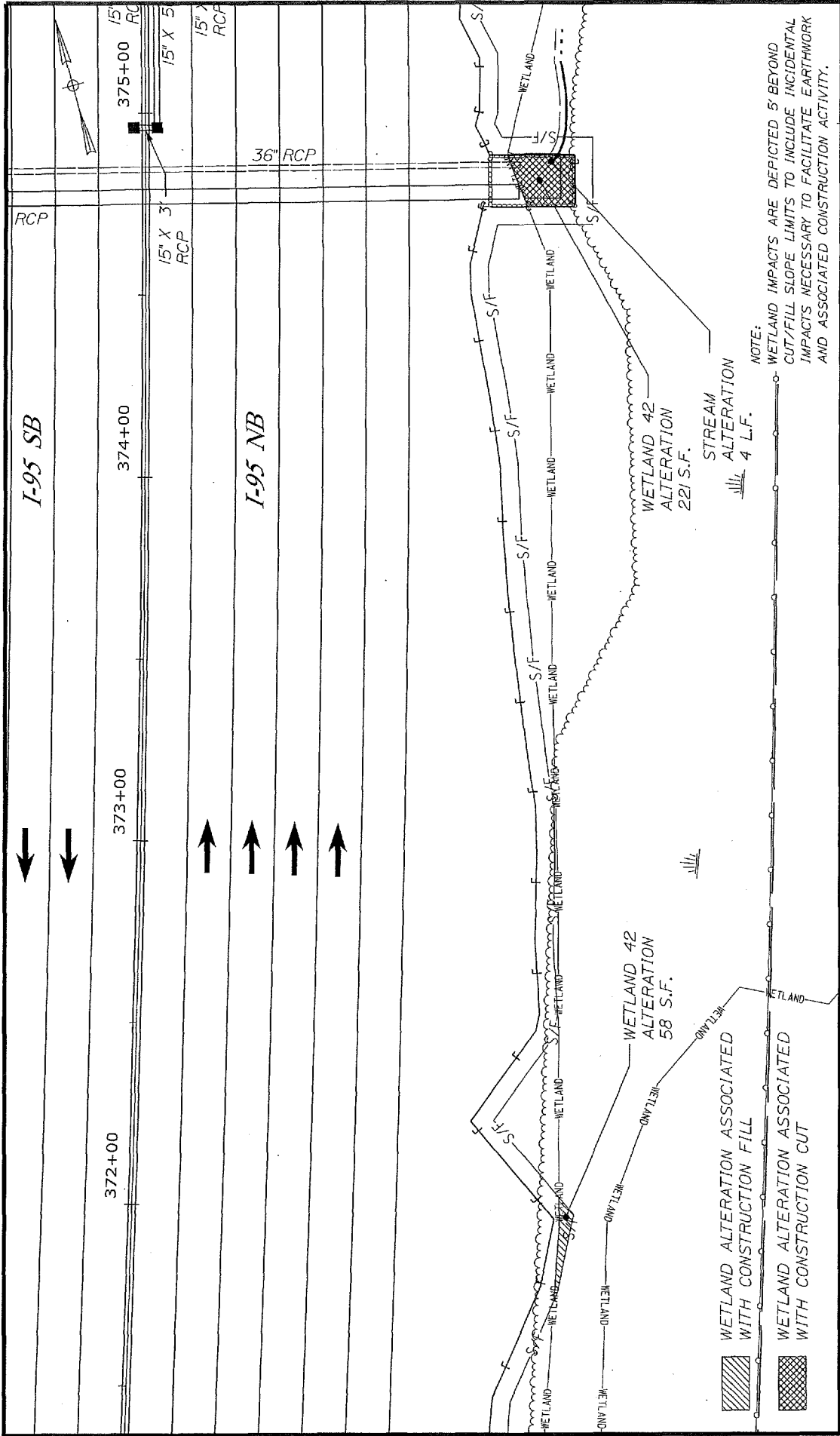

Scale: 12.5' = 1" 0 12.5' 25'

No.	Revision	By	Date
1	PROGRESS SUBMITTAL	DAM	08/20/18
2	MISCELLANEOUS REVISIONS	DAM	08/20/18
3	UPDATED WPS	DAM	07/16/18
4	REV. PER USAGE COMMENTS	DAM	07/17/17

Designed by: **SEBAGO TECHNICS**
T E C H N I C S
WWW.SEBAGOTECHNICS.COM

CONSULTANT PROJECT MANAGER: S. SANTER, P.E.
By: [Signature] Date: 1/17/17
Checked: [Signature] Date: 1/17/17
In Charge: [Signature] Date: 1/17/17

SEBAGO TECHNICS
75 JOHN ROBERTS ROAD,
SOUTH PORTLAND, ME 04106
TEL (207) 200-2100

THE GOLD STAR MEMORIAL HIGHWAY

YORK TOLL PLAZA

WETLAND 42 ALTERATION

CONTRACT: 2017.09

SHEET NUMBER: WA-M 12 OF 16

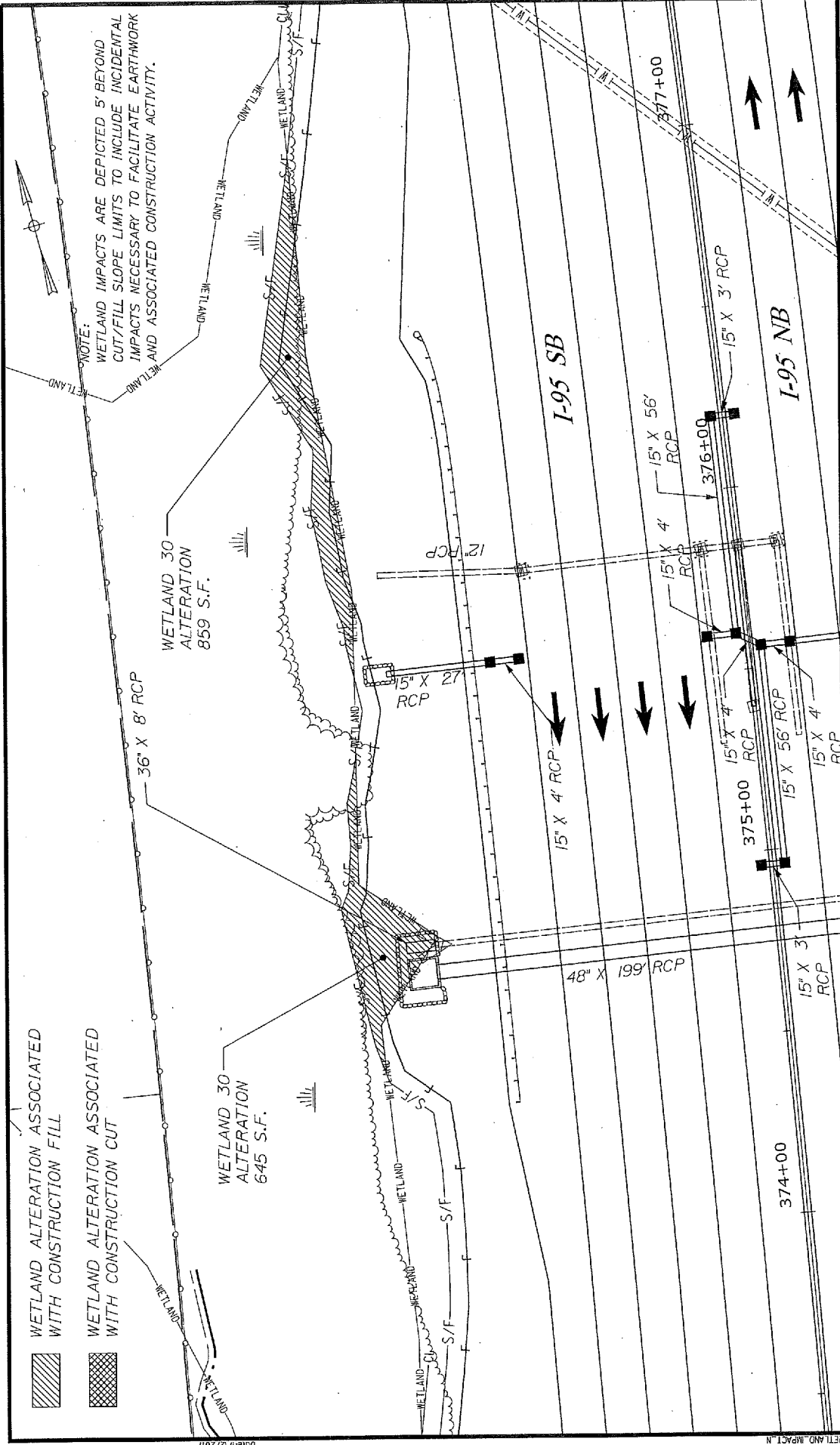

NOTE:
 WETLAND IMPACTS ARE DEPICTED 5' BEYOND CUT/FILL SLOPE LIMITS TO INCLUDE INCIDENTAL IMPACTS NECESSARY TO FACILITATE EARTHWORK AND ASSOCIATED CONSTRUCTION ACTIVITY.

WETLAND ALTERATION ASSOCIATED WITH CONSTRUCTION FILL
 WETLAND ALTERATION ASSOCIATED WITH CONSTRUCTION CUT

WETLAND 30 ALTERATION 859 S.F.

WETLAND 30 ALTERATION 645 S.F.

I-95 SB

I-95 NB

Scale: 1/2.5 0 12.5 25
 Scale of Feet

No.	Revision	By	Date
1	PROGRESS SUBMITTAL	DAM	06/20/16
2	MISCELLANEOUS REVISIONS	DAM	09/01/16
3	UPDATED MAPS	DAM	09/16/16
4	REV. PER USAGE COMMENTS	DAM	01/11/17

Designed by:
SEBAGO TECHNICS
 WWW.SEBCO7TECHNICS.COM
 CONSULTANT PROJECT MANAGER: S. SAWYER, P.E.
 Checked: OAM 1/11/17
 In Charge of: RLM 1/11/17

SEBAGO TECHNICS
 75 JOHN ROBERTS ROAD,
 SUITE 1A
 SOUTH PORTLAND, ME 04106
 TEL (207) 200-2100



THE GOLD STAR MEMORIAL HIGHWAY

YORK TOLL PLAZA
 WETLAND 30 ALTERATION

CONTRACT: 2017.09
 SHEET NUMBER: WA-N
 13 OF 16

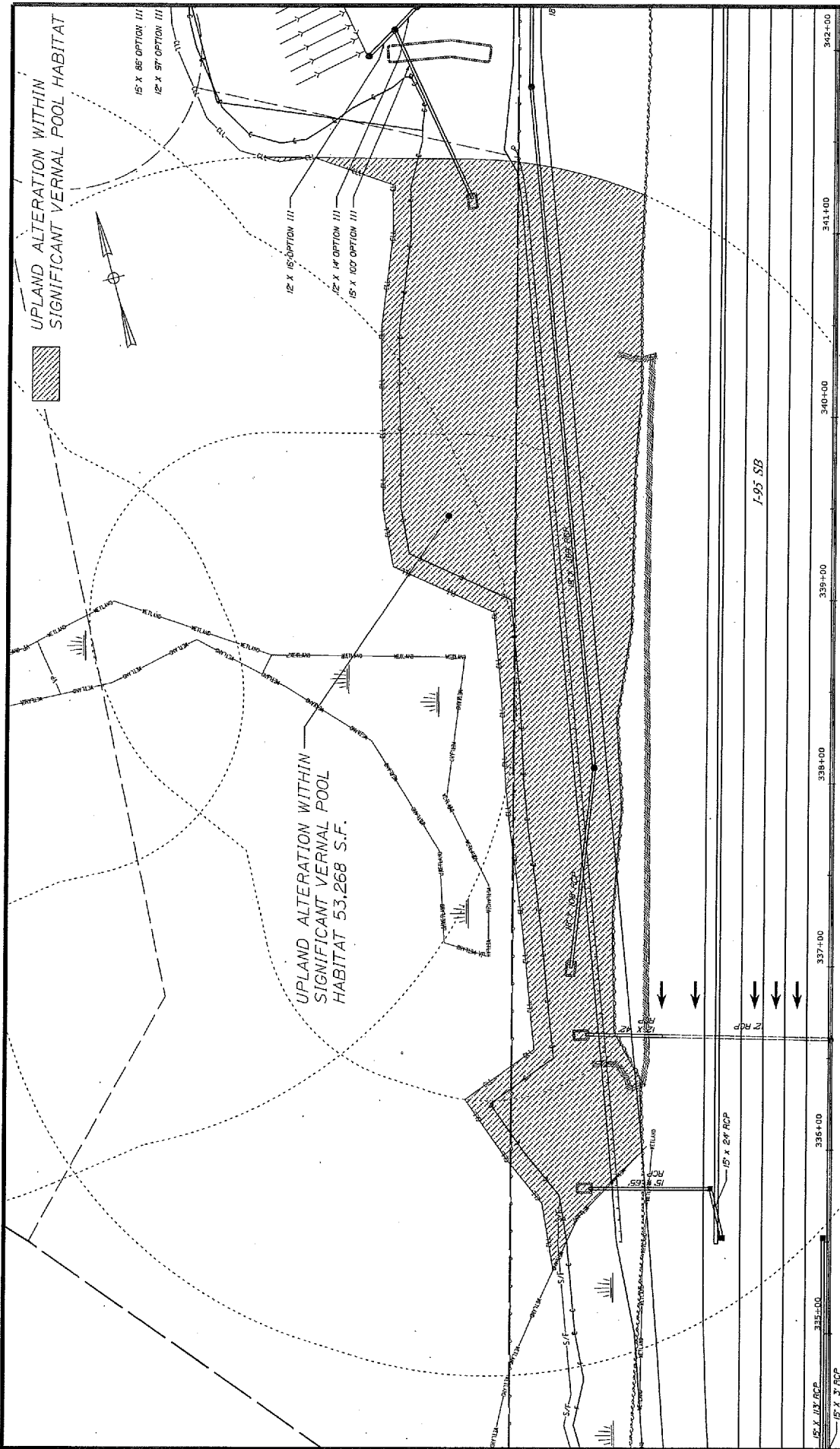

<p>Scale: 25' = 1" (Scale of Feet)</p> <p>Revised By Date</p> <p>1. PROGRESS SUBMITTAL OAM 06/20/18</p> <p>2. MISCELLANEOUS REVISIONS OAM 09/01/18</p> <p>3. REV. PER USAGE COMMENTS OAM 07/10/17</p> <p>4. REV. PER USAGE COMMENTS OAM 07/10/17</p>		<p>Designed by:</p> <p>SEBAGO TECHNICS</p> <p>T E C H N I C S</p> <p>WWW.SEBAGOTECHNICS.COM</p> <p>CONSULTANT PROJECT MANAGER: S. SWARTYER, P.E.</p> <p>By Date</p> <p>OAM 1/17/17</p> <p>Checked OAM 1/17/17</p> <p>In Charge M 1/17/17</p>	
<p>SEBAGO TECHNICS</p> <p>75 JOHN ROBERTS ROAD,</p> <p>SUITE 1A, JAE 04106</p> <p>SOUTH PORTLAND, ME</p> <p>TEL (207) 200-2100</p>		<p>THE GOLD STAR MEMORIAL HIGHWAY</p> <p>YORK TOLL PLAZA</p> <p>VERNAL POOL - 54 UPLAND HABITAT ALTERATION</p>	
<p>CONTRACT: 2017.09</p> <p>SHEET NUMBER: WA-0</p> <p>14 OF 18</p>		<p>DATE: 1/12/2017</p>	

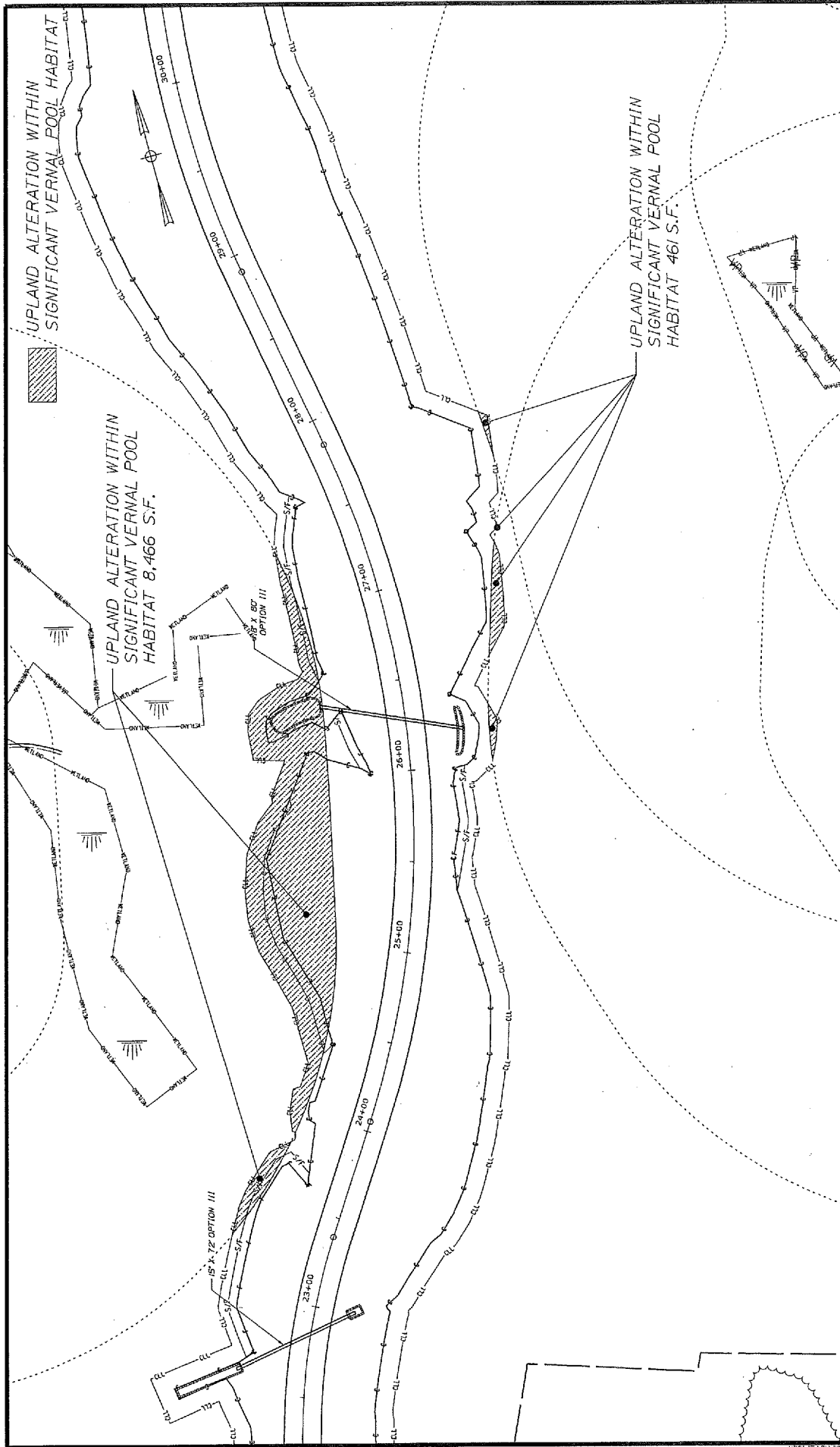

Scale: 25' = 1" 0' 25' 50' Scale of Feet

No.	Revision	By	Date
1	PROGRESS SUBMITTAL	DAM	06/20/16
2	MISCELLANEOUS REVISIONS	DAM	09/07/16
3	UPDATED MAPS	DAM	09/16/16
4	REV. PER USACE COMMENTS	DAM	07/11/17

Designed by: **SEBAGO TECHNICS**
 WWW.SEBAGOTECHNICS.COM
 CONSULTANT PROJECT MANAGER: S. SAWYER, P.E.
 By: [Signature] Date: 7/17/17
 Checked: [Signature] Date: 7/17/17
 In Charge of [Signature] Date: 7/17/17

SEBAGO TECHNICS
 75 JOHN ROBERTS ROAD,
 SOUTH PORTLAND, ME 04106
 TEL (207) 200-2100

THE GOLD STAR MEMORIAL HIGHWAY

YORK TOLL PLAZA
 VERNAL POOL - 54 AND 56
 UPLAND HABITAT ALTERATION

CONTRACT: 2017.09
 SHEET NUMBER: WA-P
 15 OF 16

Date: 12/20/2017

Filename: \\MSTAVRELL\ND\IMPACT_P.dwg

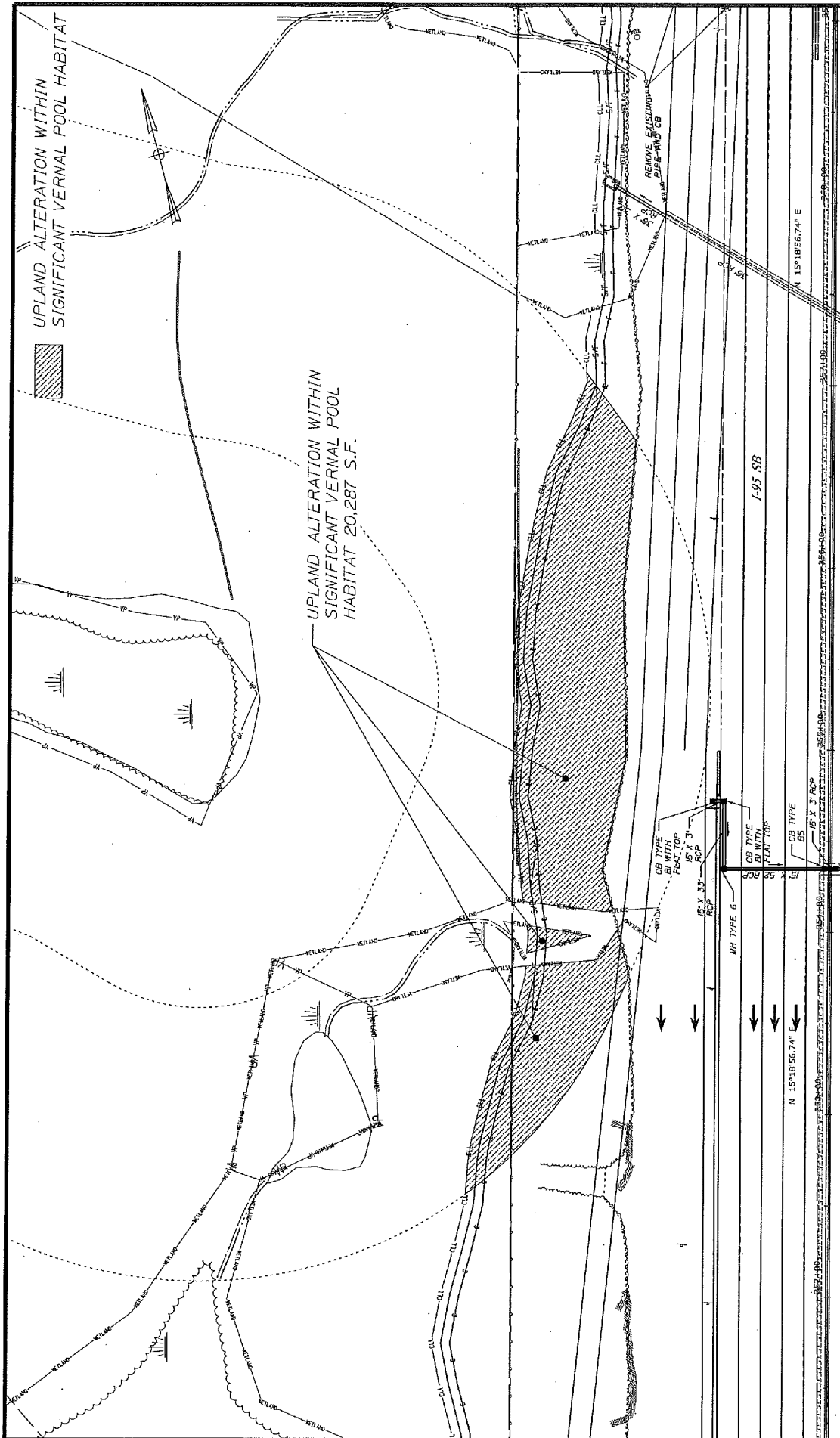

Scale: 25 0 25 50
Scale of Feet

No.	PROGRESS	REVISION	DATE	BY
1	PROGRESS	REVISION	03/20/16	CAJ
2	MISC. ANNOTS.	REVISION	03/20/16	CAJ
3	UPDATED MAPS	REVISION	03/24/16	CAJ
4	REV. PER USAGE	COMMENTS	01/11/17	CAJ

Designed by: **SEBAGO TECHNICS**
 T E C H N I C S
 WWW.SEAGOTECHNICS.COM
 CONSULTANT PROJECT MANAGER: S. SWARTZ, P.E.
 CAJ 1/11/17 Checked CAJ 1/11/17
 CAJ 1/11/17 Drawn CAJ 1/11/17

SEBAGO TECHNICS
 75 JOHN ROBERTS ROAD,
 SOUTH PORTLAND, ME 04106
 TEL (207) 200-2100

THE GOLD STAR
 MEMORIAL HIGHWAY

YORK TOLL PLAZA
 VERNAL POOL - 13 UPLAND
 HABITAT ALTERATION

CONTRACT: 2017-09
 SHEET NUMBER: WA-Q
 16 OF 16

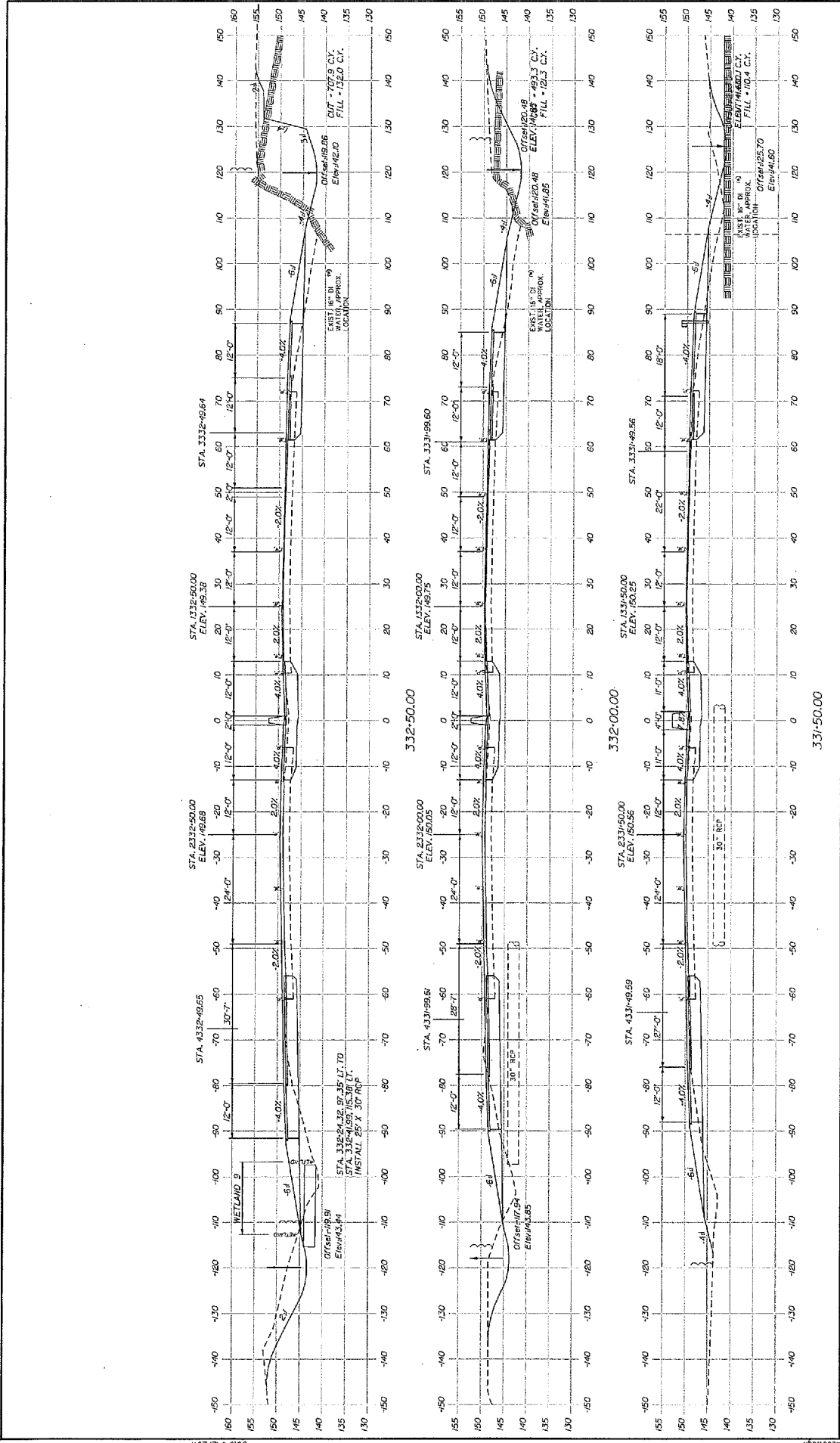

Scale: Horiz. 1" = 20' Vert. 1" = 5' Scale of Part 5

No.	Revision	By	Date

Designed by: **JACOBS**

CONSULTANT PROJECT MANAGER: **PROMANAGER'S**

By	Date	By	Date
ANS	08/16	CSM	08/16
SMG	08/16	In Charge of	---/---/---

JACOBS ENGINEERING GROUP
345 CONGRESS STREET
PORTLAND, ME 04101
TEL (617) 242-9224
FAX (617) 242-9824

THE GOLD STAR MEMORIAL HIGHWAY

1-95 CROSS SECTIONS
STA. 331+50 TO STA. 332+50

CONTRACT: WIN
MTA PROJECT MANAGER: R. NORWOOD
SHEET NUMBER: XS-4.4
SPSET18 OF

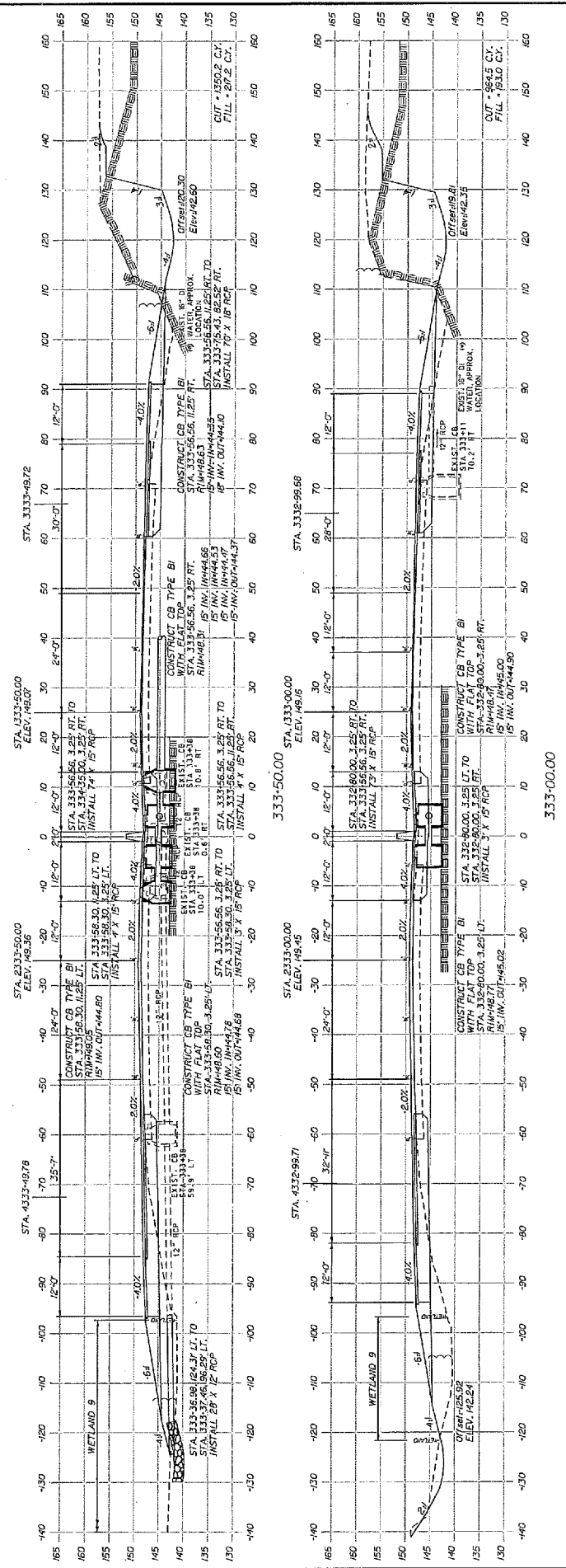

Scale: 1" = 20' (Scale of Feet)

No.	Revision	By	Date

Designed by: _____

Checked by: _____

Date: _____

CONSULTANT PROJECT MANAGER: PROJMANAGERS

By	Date	By	Date
AMS	06/16	PSM	06/16
SMG	07/16		

DATE: 07/16

BY: _____

THE GOLD STAR MEMORIAL HIGHWAY

1-95 CROSS SECTIONS
STA. 333+00 TO STA. 333+50

JACOBS ENGINEERING GROUP
343 CONGRESS STREET
BOSTON, MA 02210
TEL (617) 242-9222
FAX (617) 242-9824

CONTRACT: WINN
MTA PROJECT MANAGER: R. DURWOOD
SHEET NUMBER: XS-45
P-SETS OF

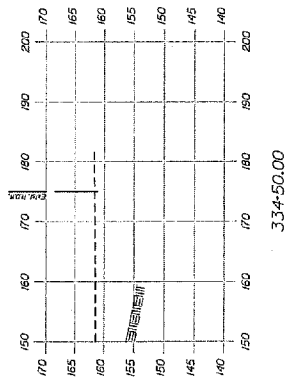

334+50.00

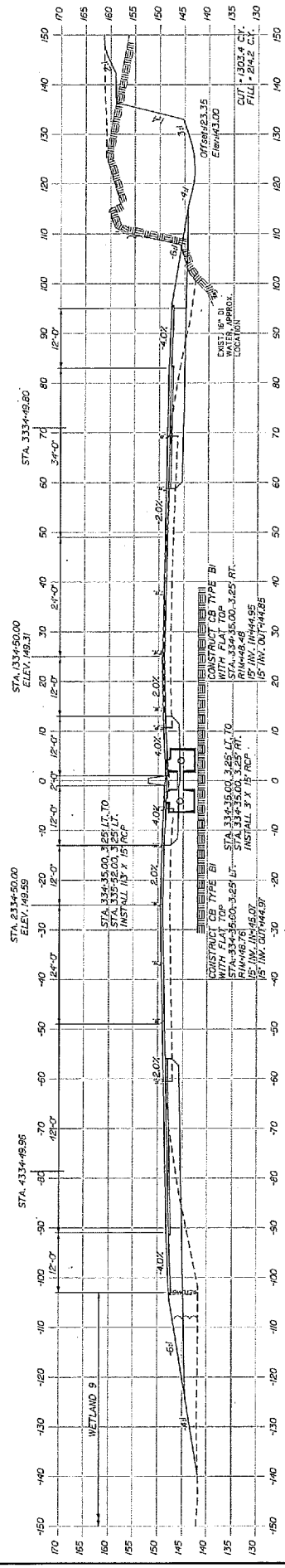

334+50.00

		THE GOLD STAR MEMORIAL HIGHWAY		I-95 CROSS SECTIONS STA. 334+50		SHEET NUMBER: XS-47 SP-SETS OF	
JACOBS ENGINEERING GROUP 348 CONGRESS STREET BOSTON, MA 02210 TEL (617) 242-9222 FAX (617) 242-9824				MTA PROJECT MANAGER: R. BURWOOD CONTRACT: WIN			
JACOBS		Designed by:		Scale:		No.	
CONSULTANT PROJECT MANAGER: #PROJMANAGER		By:		Date:		Revision	
Checked:		By:		Date:		Description	
Drawn:		By:		Date:		Description	

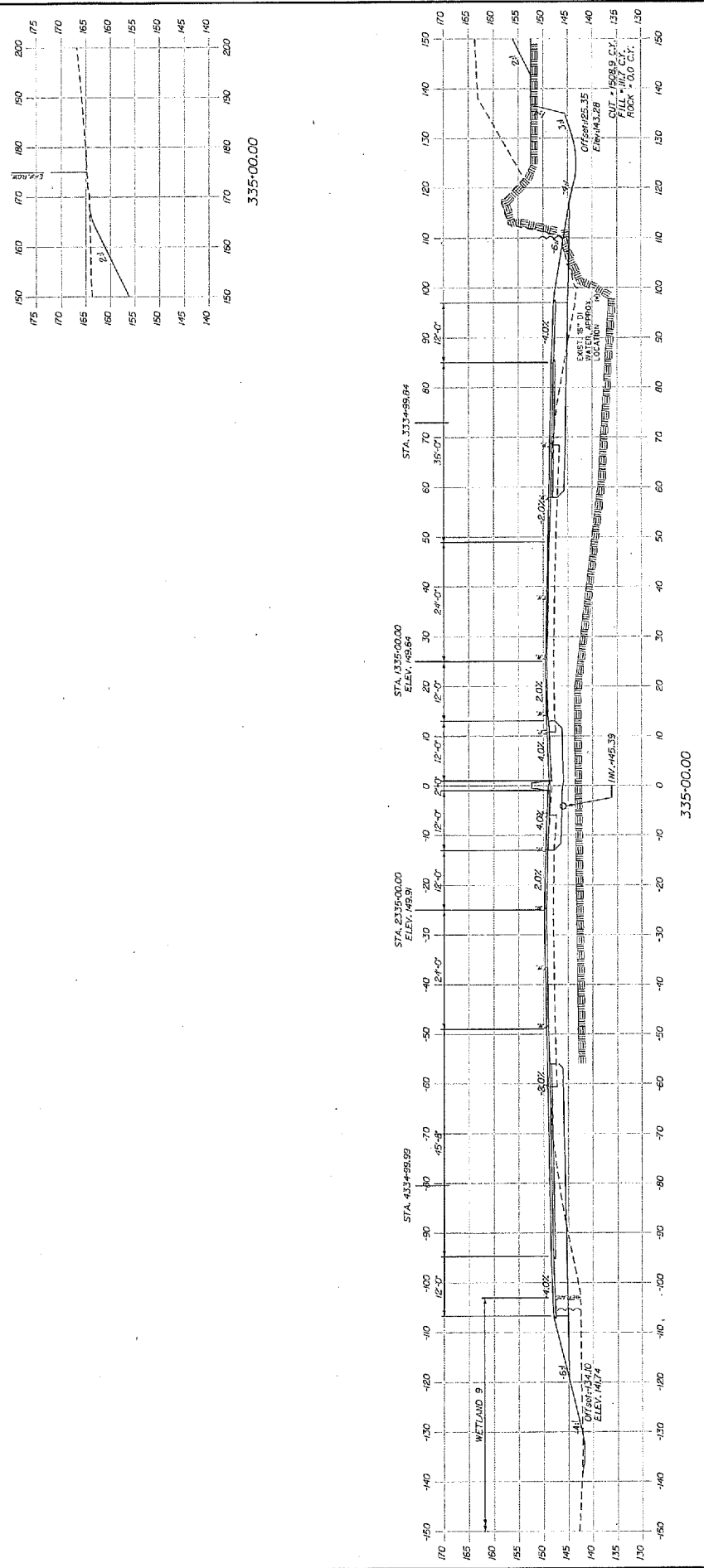

Scale:

No.	Revision	By	Date

Designed by:

JACOBS

CONSULTANT PROJECT MANAGER: PROJMANAGER

Drawn	By	Date	Checked	By	Date
AMS	AMS	06/7/16	CSM	CSM	08/7/16
Drawn	SMG	06/7/16	In Charge of	---	---

THE GOLD STAR MEMORIAL HIGHWAY

MTA PROJECT MANAGER: R. NORWOOD

I-95 CROSS SECTIONS
STA. 335+00

SHEET NUMBER: XS-48
SPSCTS-0F

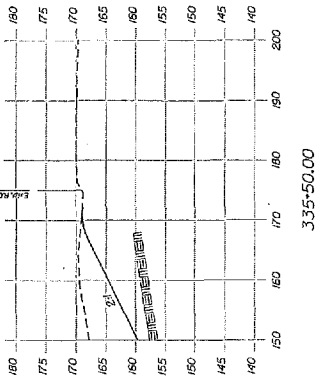

335-50.00

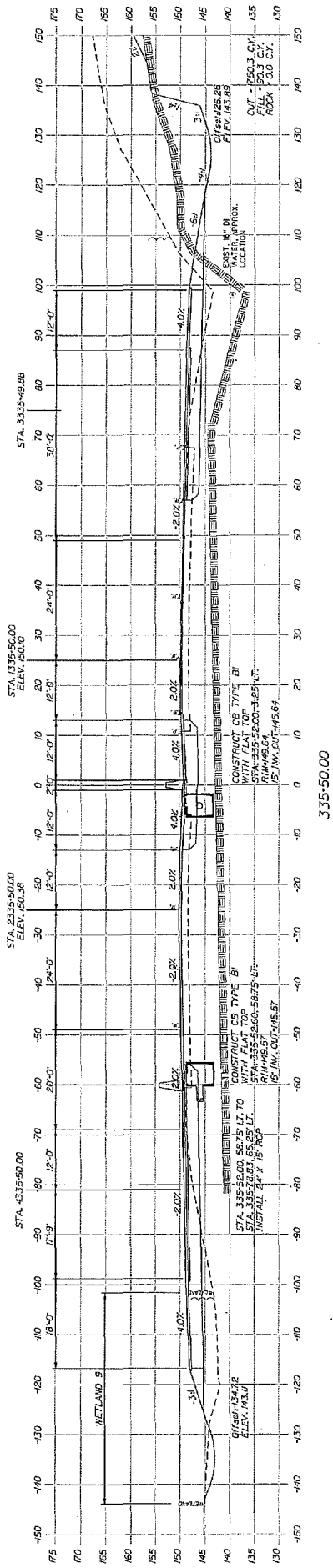

335-50.00

JACOBS

DESIGNED BY:

No.	Revision	By	Date

JACOBS ENGINEERING GROUP
 343 CONGRESS STREET
 BOSTON, MA 02210
 TEL (617) 242-9222
 FAX (617) 242-9824

CONSULTANT PROJECT MANAGER: SPON/MANAGER

By	Date	By	Date

CONTRACT: WIN

SHEET NUMBER: XS-49

OF 95 SETS OF

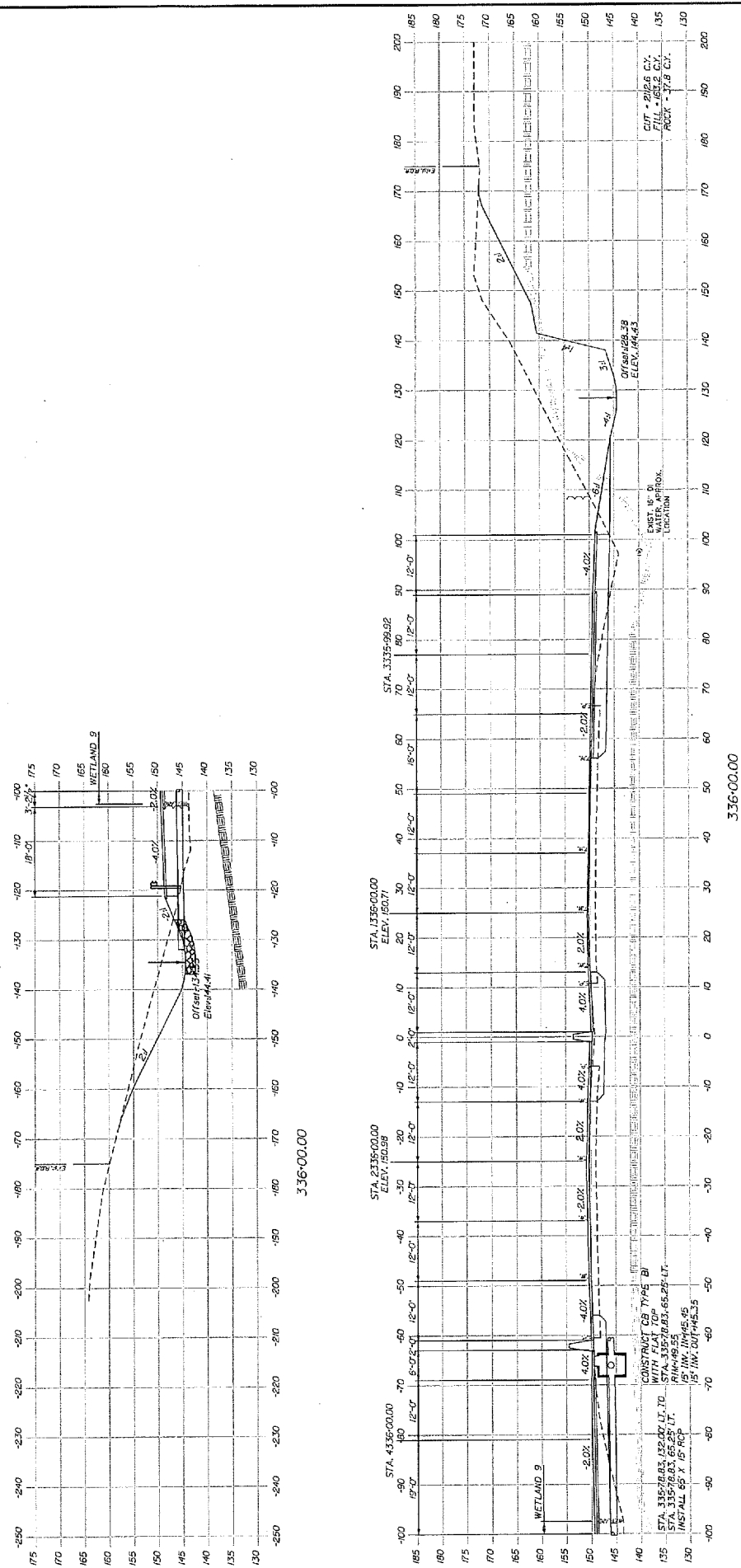

Scale: 1" = 20' (Scale of Feet)

No.	By	Date	Revision

Designed by: _____
 Checked: _____
 In Charge of: _____

CONSULTANT PROJECT MANAGER: PROJECT MANAGER
 By: _____ Date: _____
 AMS: _____ CSH: _____
 SWS: _____ CB/TB: _____

JACOBS

JACOBS ENGINEERING GROUP
 343 CONGRESS STREET
 BOSTON, MA 02210
 TEL (617) 242-9222
 FAX (617) 242-9824

MAINE TURNPIKE

THE GOLD STAR MEMORIAL HIGHWAY

STA. 336+00.00

I-95 CROSS SECTIONS
 STA. 336+00

CONTRACT: WIN
 MTA PROJECT MANAGER: R. NORWOOD
 SHEET NUMBER: XS-4.7
 \$PSETS OF

Date: 11/2/2017

Filename: \\MS1\AD\RP\00-4581.dgn

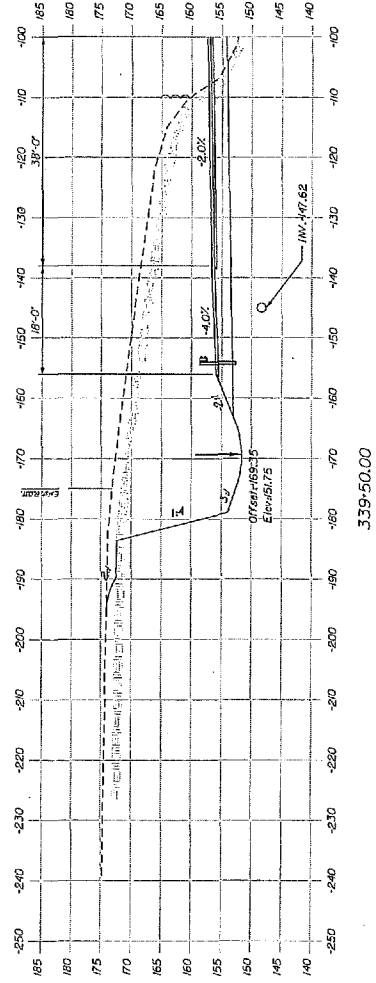

339+50.00

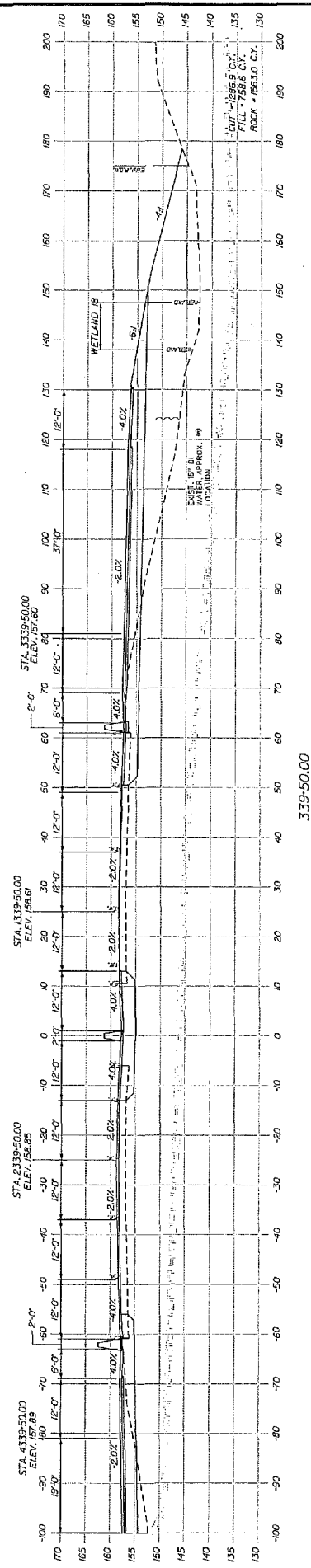

339+50.00

Scale:
 1" = 20'
 1" = 40'
 1" = 80'
 1" = 160'

Revised By Date

CONSULTANT PROJECT MANAGER: PROGRAM MANAGER

Designed	AMS	08/16	Checked	CSM	08/16	Plotted	CSM	08/16
Drawn	SMG	08/16	In Charge of					

THE GOLD STAR MEMORIAL HIGHWAY

CONTRACT: WIN

SHEET NUMBER: XS-54

SP-SETS OF

JACOBS' PROJECT MANAGER: PROGRAM MANAGER

JACOBS ENGINEERING GROUP
 343 CONGRESS STREET
 BOSTON, MA 02210
 TEL (617) 242-9222
 FAX (617) 242-9824

UTA PROJECT MANAGER: E. NORRICO

1-95 CROSS SECTIONS
 STA. 339+50

Scale:
 1" = 20'
 1" = 40'
 1" = 80'
 1" = 160'

Revised By Date

CONSULTANT PROJECT MANAGER: PROGRAM MANAGER

Designed	AMS	08/16	Checked	CSM	08/16	Plotted	CSM	08/16
Drawn	SMG	08/16	In Charge of					

THE GOLD STAR MEMORIAL HIGHWAY

CONTRACT: WIN

SHEET NUMBER: XS-54

SP-SETS OF

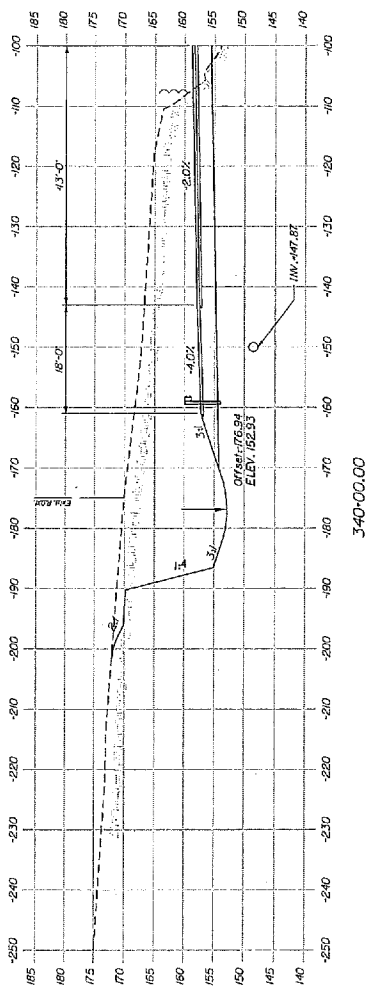

340+00.00

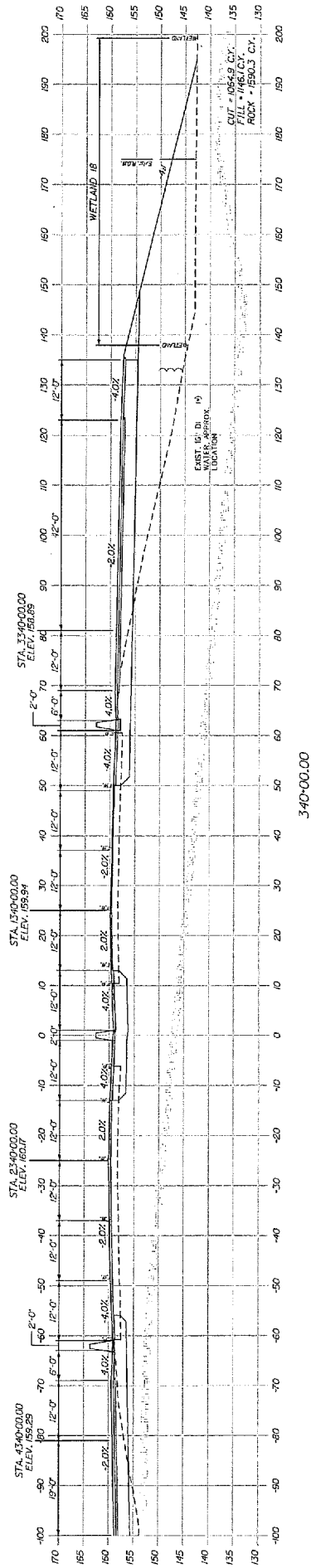

340+00.00

Scale: 1" = 20' Scale of Feet

No.	Revision	By	Date

Designed by:

Consultant	Project Manager	By	Date
JACOBS	PROJMANAGER	CSM	08/16

JACOBS ENGINEERING GROUP
 343 CONGRESS STREET
 SUITE 100
 TEL (617) 242-9224
 FAX (617) 242-9824

**THE GOLD STAR
 MEMORIAL HIGHWAY**

MTA PROJECT MANAGER: P. NORWOOD

I-95 CROSS SECTIONS
 STA. 340+00

SHEET NUMBER: XS-55
 #SETS OF

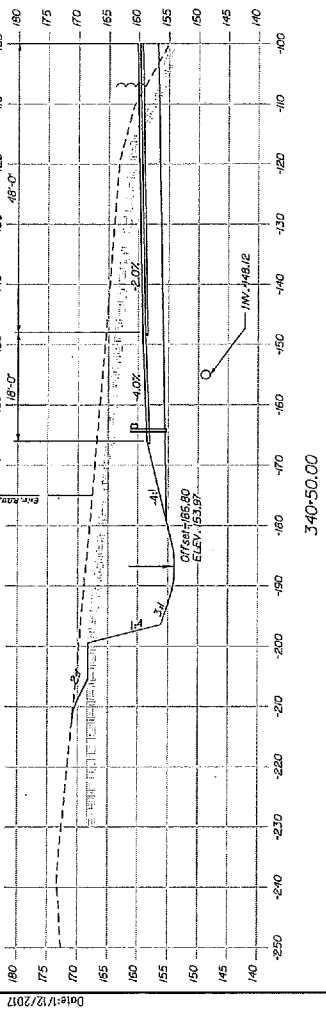

340+50.00

340+50.00

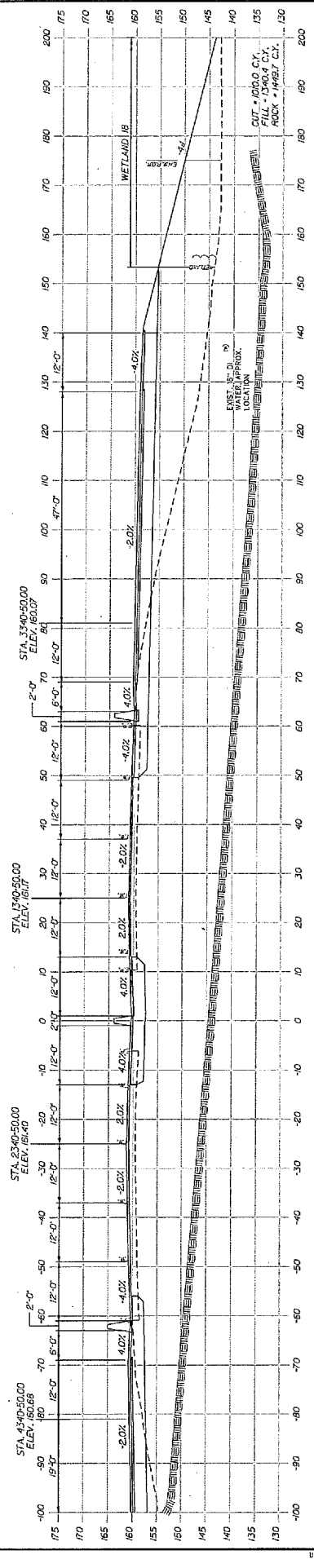

340+50.00



No.	By	Date

Designed by:

JACOBS

CONSULTANT PROJECT MANAGER: EPO-MANAGERS

Prepared	By	Date	Checked	By	Date
	JMS	08/16		CSM	08/16
	SMG	08/16	In Charge of	---	--/--

JACOBS ENGINEERING GROUP
345 CONSUMERS STREET
BOSTON, MA 02210
TEL (617) 242-9222
FAX (617) 242-9824



**THE GOLD STAR
MEMORIAL HIGHWAY**

MTA PROJECT MANAGER: R. DRIVWOOD

CONTRACT:WIN

**1-95 CROSS SECTIONS
STA. 340+50**

SHEET NUMBER: XS-56
SPS ETS OF

Date: 1/12/2017

Filename: \\MSTAR\RP\10n\195et.dgn

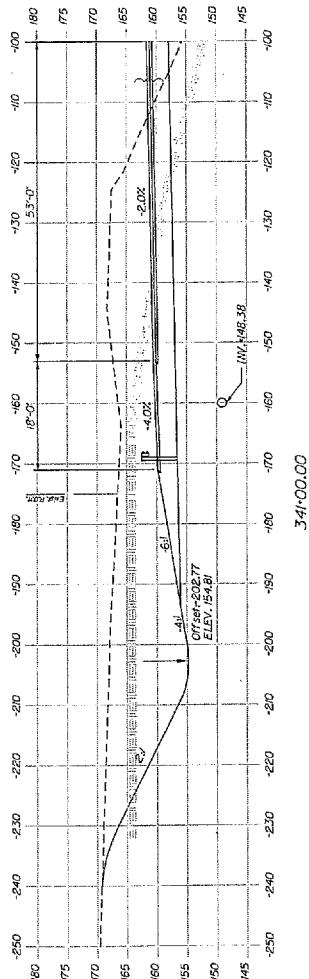

341+00.00

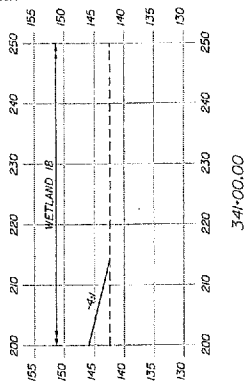

341+00.00

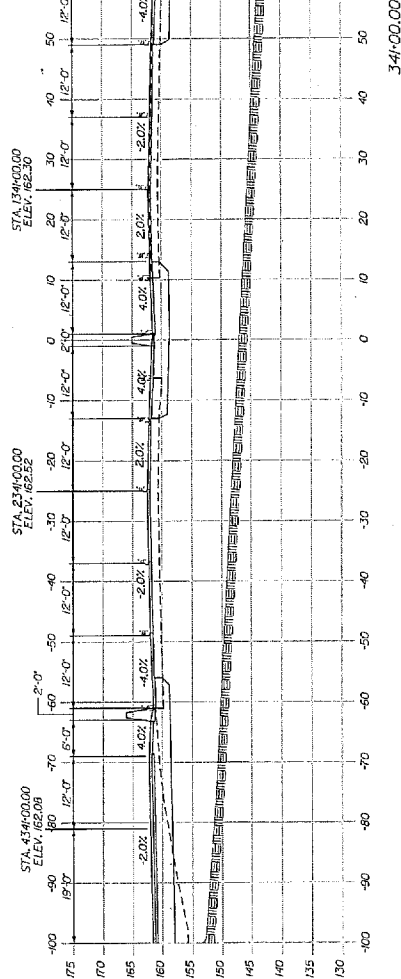

341+00.00

Scale: 1" = 20' Scale of Feet

Designed by:

No.	Revision	By	Date

Designd	By	Date	Project Manager	By	Date
Brown	JMS	08/16	PROJMANAGERS	CSM	08/16

Designed by: **JACOBS**

CONSULTANT PROJECT MANAGER: PROJMANAGERS

JACOBS ENGINEERING GROUP
 343 CONGRESS STREET
 BOSTON, MA 02210
 TEL (617) 242-9222
 FAX (617) 242-9624



**THE GOLD STAR
MEMORIAL HIGHWAY**

I-95 CROSS SECTIONS
STA. 341+00

CONTRACT: WIN

W.F.A. PROJECT MANAGER: B. NORWOOD

SHEET NUMBER: XS-57
8 OF 10 SETS OF

Date: 1/12/2017

Filename: \\MS1A\B\proj\155\cd\dwg

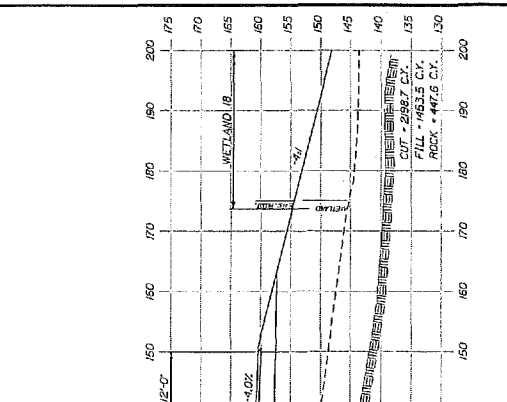
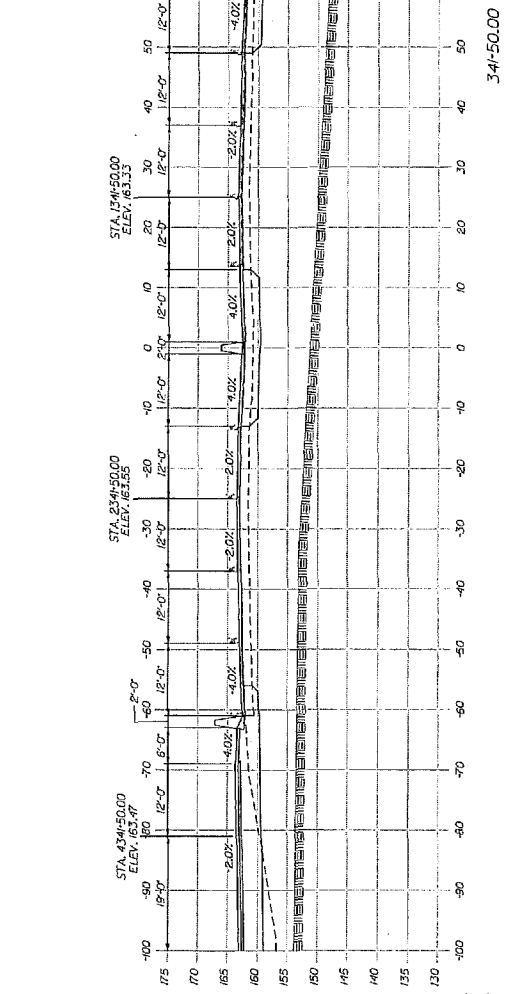
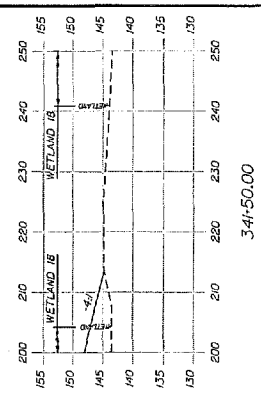
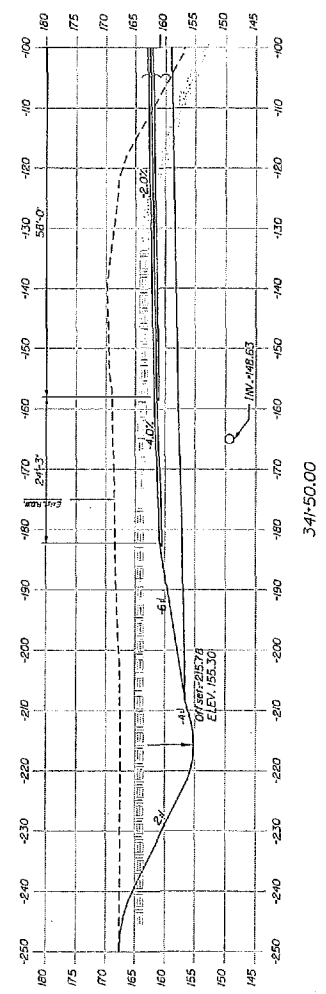

Scale:

No.	Revision	By	Date

Designed by:	Checked:	By:	Date:
SMG	SMG	SMG	08/16

Designed by: **JACOBS**

CONSULTANT PROJECT MANAGER: PROGRAM MANAGERS

343 CONGRESS STREET
BOSTON, MA 02210
TEL (617) 242-9222
FAX (617) 242-9824



**THE GOLD STAR
MEMORIAL HIGHWAY**

I-95 CROSS SECTIONS
STA. 341+50

CONTRACT: WIN

SHEET NUMBER: XS-58
3P SET OF

Date: 11/2/2017

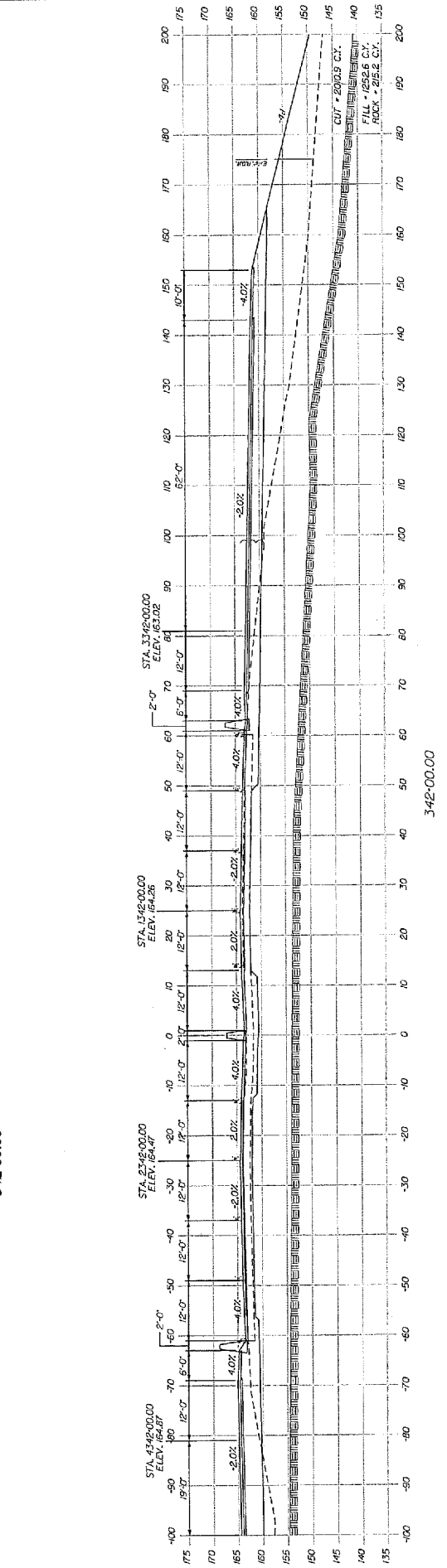
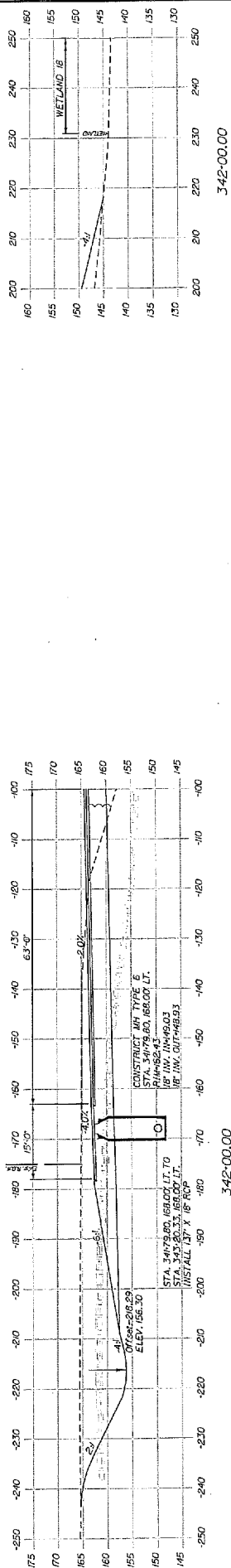

Scale: 1" = 20'
Scale of feet

Designed by:

No.	Revision	By	Date

CONSULTANT PROJECT MANAGER: PROJMANAGER

Drawn	Checked	By	Date
Brown			

AMS OB/16
SMC OB/16
In Charge of

JACOBS ENGINEERING GROUP
343 CONGRESS STREET
BOSTON, MA 02210
TEL (617) 242-9222
FAX (617) 242-9824

THE GOLD STAR
MEMORIAL HIGHWAY

WTA PROJECT MANAGER: R. KIRKWOOD

I-95 CROSS SECTIONS
STA. 342+00

SHEET NUMBER: XS-59
SSETS OF

CONTRACT: WIN

CONSTRUCT MIN TYPE 6
 15" MIN. IN-40.33, 165.00 LT.
 15" MIN. IN-55.00
 15" MIN. IN-60.89
 15" MIN. IN-60.00
 15" MIN. OUT-45.75

QUANTITY MATCH LINE
 (SEE SITE PLAN)

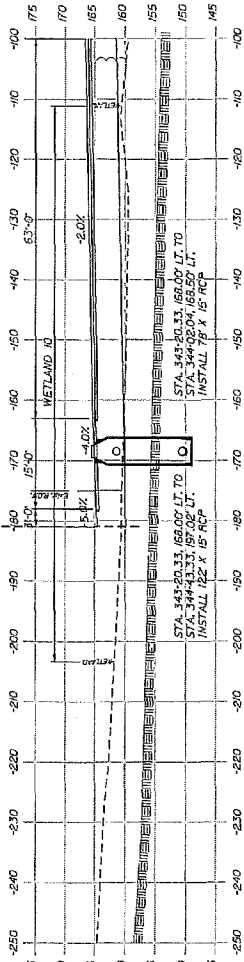

343+00.00

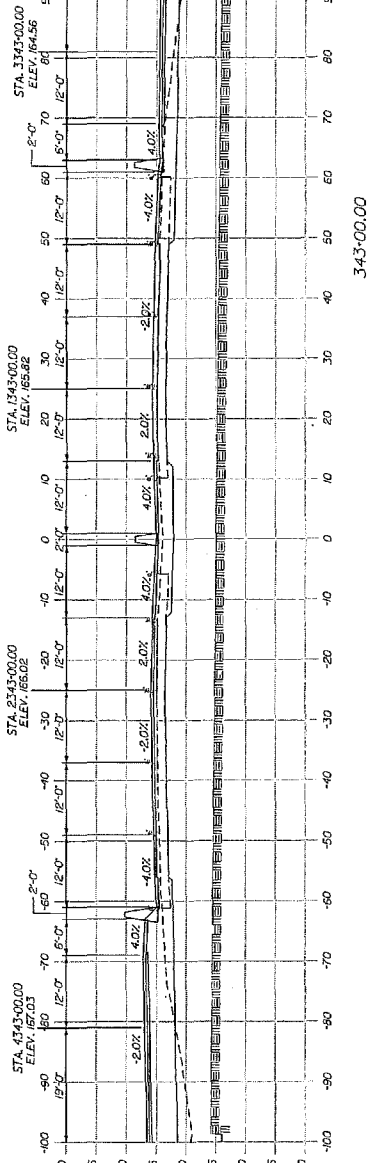

343+00.00

Scale:
 1" = 20'
 Scale of Feet

No.	Revision	By	Date

Designed by:

DESIGNED	BY	DATE	BY	DATE
DESIGNED	BY	DATE	BY	DATE
DESIGNED	BY	DATE	BY	DATE
DESIGNED	BY	DATE	BY	DATE

JACOBS ENGINEERING GROUP
 343 CONGRESS STREET
 BOSTON, MA 02210
 TEL (617) 242-9222
 FAX (617) 242-9824



THE GOLD STAR
 MEMORIAL HIGHWAY

I-95 CROSS SECTIONS
 STA. 343+00

CONTRACT: WIN
 SHEET NUMBER: XS-61
 SPSE18 OF

QUANTITY MATCH LINE
SEE SITE PLAN

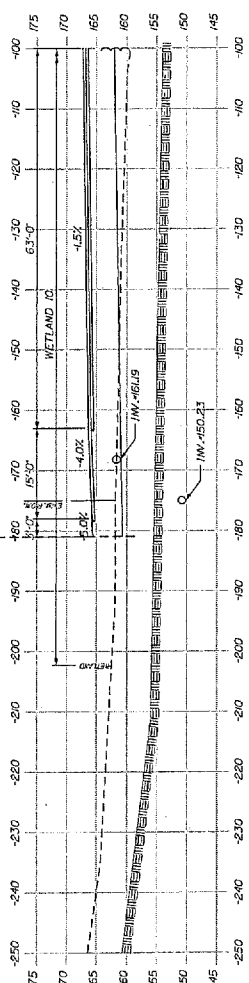

343-50.00

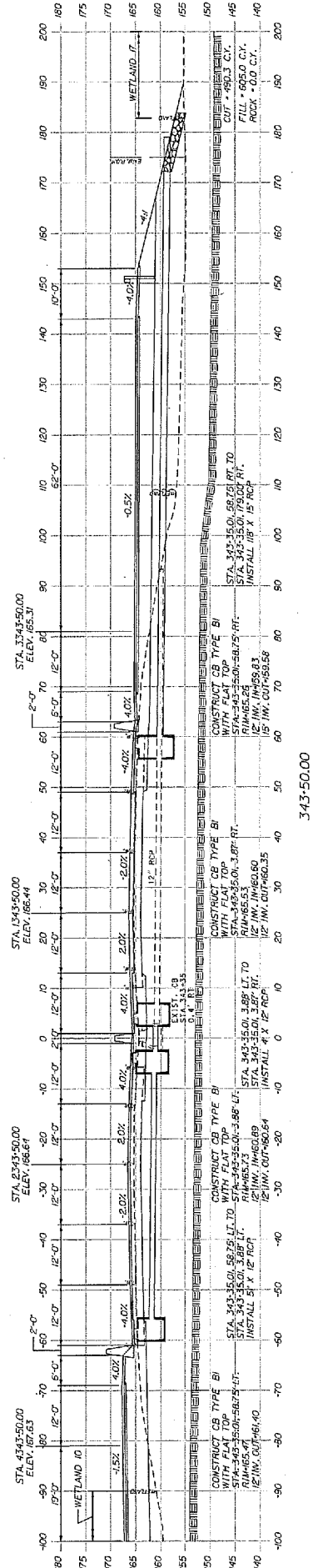

343-50.00

Scale: 1" = 30'

No.	Revision	By	Date

Designed by:

Designated	Checked	In Charge of	By	Date

JACOBS

JACOBS ENGINEERING GROUP
343 CONGRESS STREET
BOSTON, MA 02210
TEL (617) 242-9222
FAX (617) 242-9824



**THE GOLD STAR
MEMORIAL HIGHWAY**

I-95 CROSS SECTIONS
STA. 343+50

CONTRACT: WIN
SHEET NUMBER: XS-92
SPS: 1 OF 10

Date: 1/12/2017

Project: \\MSTA\RD\proj\15ec1.dwg

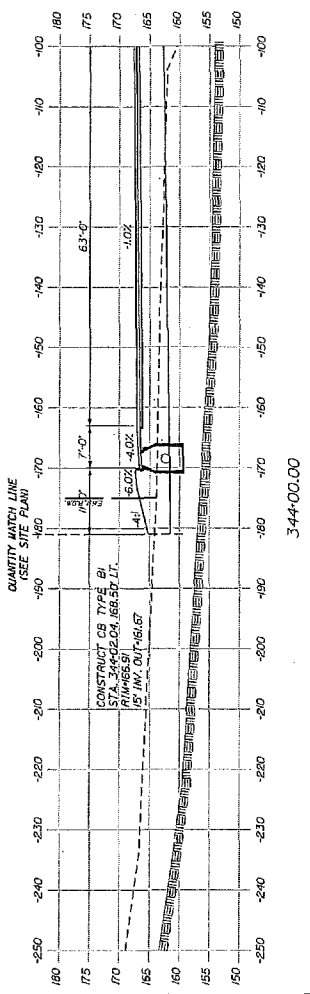

344+00.00

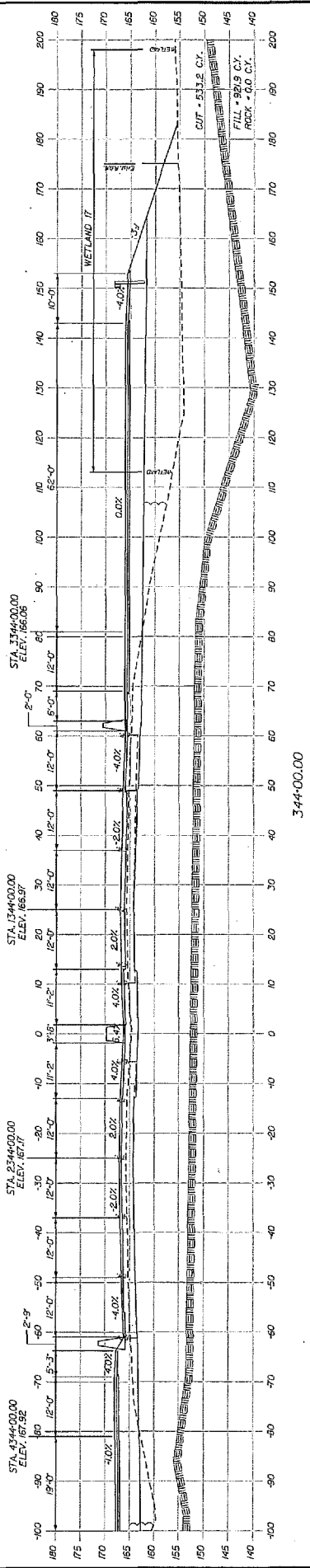

344+00.00

Scale: 1" = 20'

No.	By	Date

Designed by:

Checked	By	Date

CONSULTANT PROJECT MANAGER: PROJMANAGER

Checked	By	Date

JACOBS ENGINEERING GROUP
 343 CONGRESS STREET
 BOSTON, MA 02210
 TEL (617) 242-9222
 FAX (617) 242-9824



THE GOLD STAR
 MEMORIAL HIGHWAY

MTA PROJECT MANAGER: R. MORWOOD
 CONTRACT: WIN
 SHEET NUMBER: XS-63
 SHEET 1 OF 8

I-95 CROSS SECTIONS
 STA. 344+00

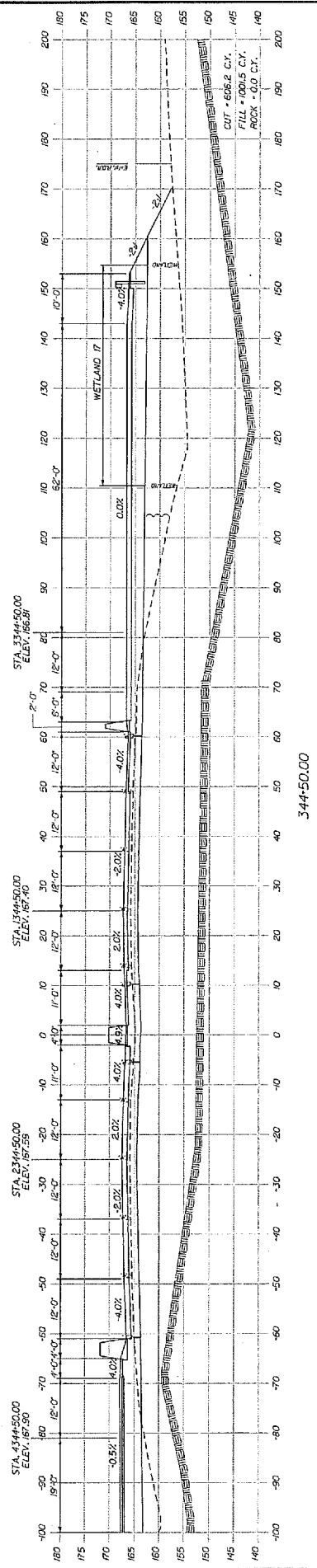
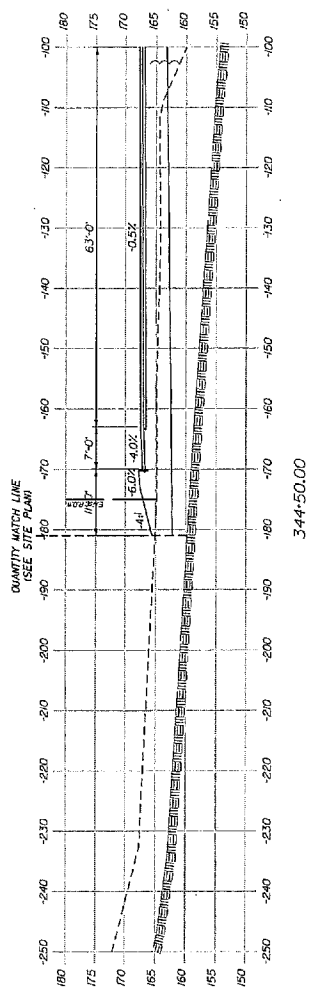

Scale: 1" = 20' (Scale of Feet)

No.	Revision	By	Date

Designed by: JACOBS

Drawn	Checked	In Charge of	By	Date
SMG	AMS	OB/16	CSM	OB/16

CONSULTANT PROJECT MANAGER: PRO/MANAGER'S

JACOBS ENGINEERING GROUP
 343 CONGRESS STREET
 SUITE 200
 TEL (617) 242-9224
 FAX (617) 242-9824

THE GOLD STAR
 MEMORIAL HIGHWAY

MTA PROJECT MANAGER: R. NORWOOD

I-95 CROSS SECTIONS
 STA. 344+50

SHEET NUMBER: XS-64
 SHEETS OF

QUANTITY MATCH LINE
(SEE SITE PLAN)

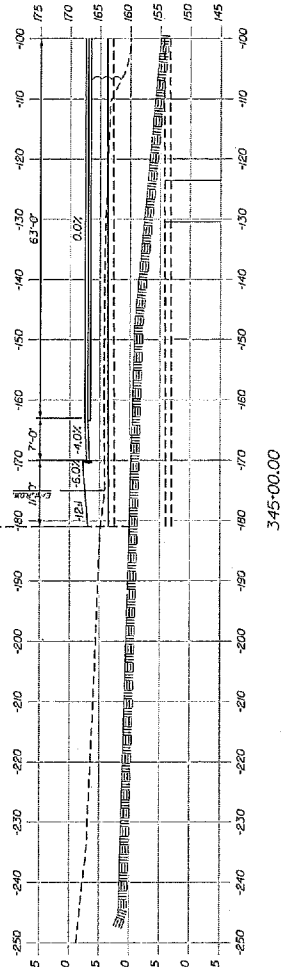

345+00.00

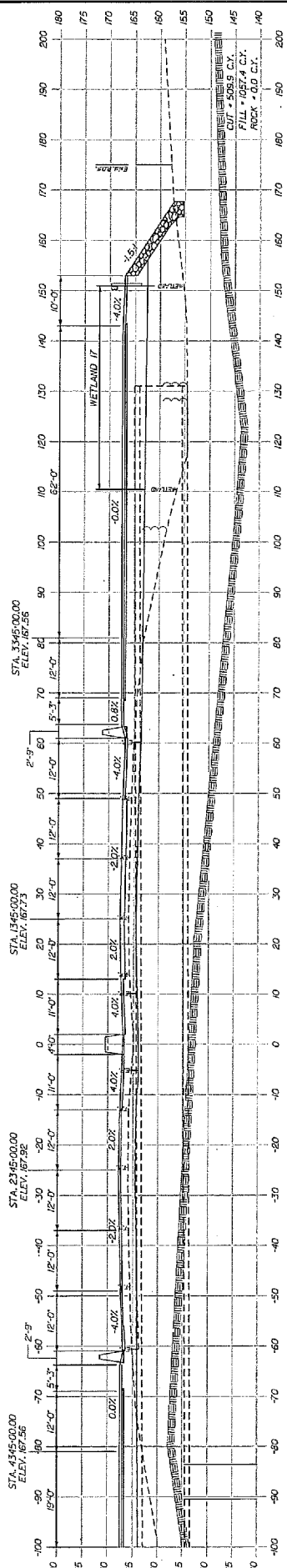

345+00.00



Designed by:



CONSULTANT PROJECT MANAGER: PROJMANAGERS	
Designed	Checked
Drawn	In Charge of
By: [Signature]	By: [Signature]
Date: 08/16	Date: 08/16
Checked: [Signature]	Checked: [Signature]
In Charge of: [Signature]	In Charge of: [Signature]

JACOBS ENGINEERING GROUP
343 CONGRESS STREET
BOSTON, MA 02210
TEL (617) 242-9222
FAX (617) 242-9924



THE GOLD STAR
MEMORIAL HIGHWAY

1-95 CROSS SECTIONS
STA. 345+00

MTA PROJECT MANAGER: R. WOODWARD

SHEET NUMBER: XS-65
9 OF 10 SHEETS

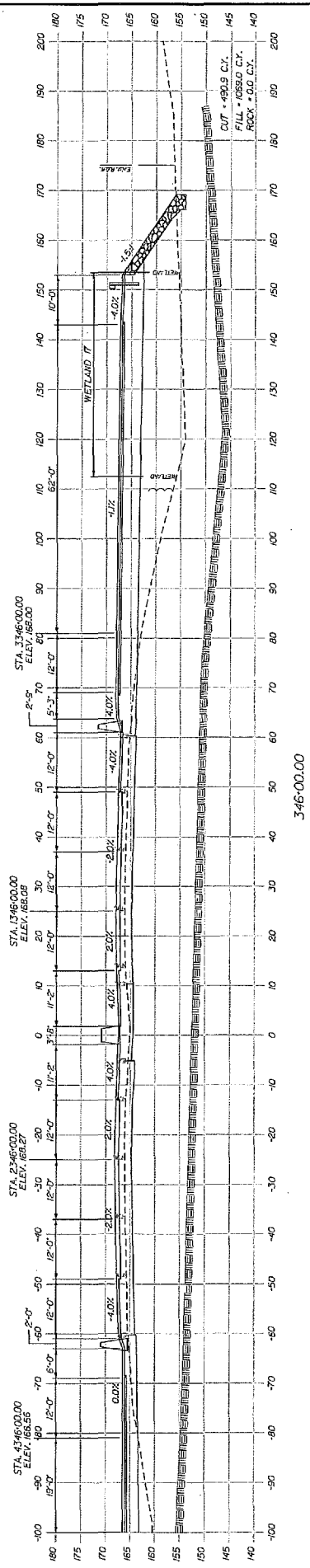
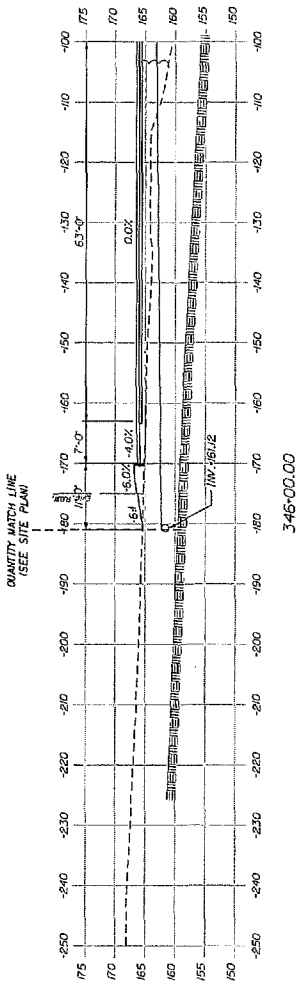

Scale: 1" = 20' (Scale of Plan)

No.	Revision	By	Date

Designed by: _____

By	Date	By	Date
AVS	08/16	CSM	08/16
SVG	08/16		

DESIGNED BY: _____
 CHECKED BY: _____
 PROJECT MANAGER: _____

DESIGNED BY: _____
 CHECKED BY: _____
 PROJECT MANAGER: _____

THE GOLD STAR MEMORIAL HIGHWAY

JACOBS ENGINEERING GROUP
 343 CONGRESS STREET
 BOSTON, MA 02210
 TEL (617) 242-9222
 FAX (617) 242-9824

CONTRACT: WIN
 MTA PROJECT MANAGER: R. NORWOOD
 SHEET NUMBER: XS-67
 SP-SETS OF

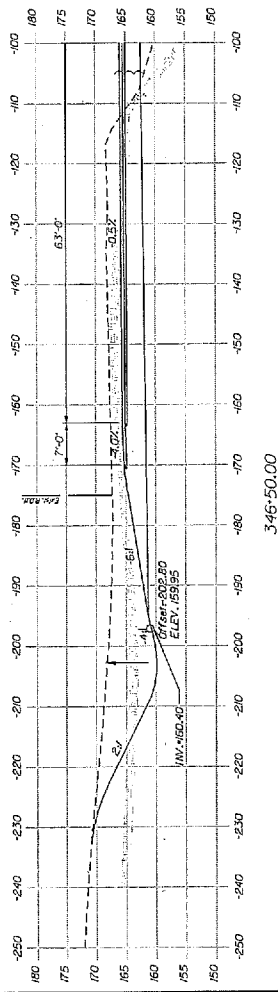

346+50.00

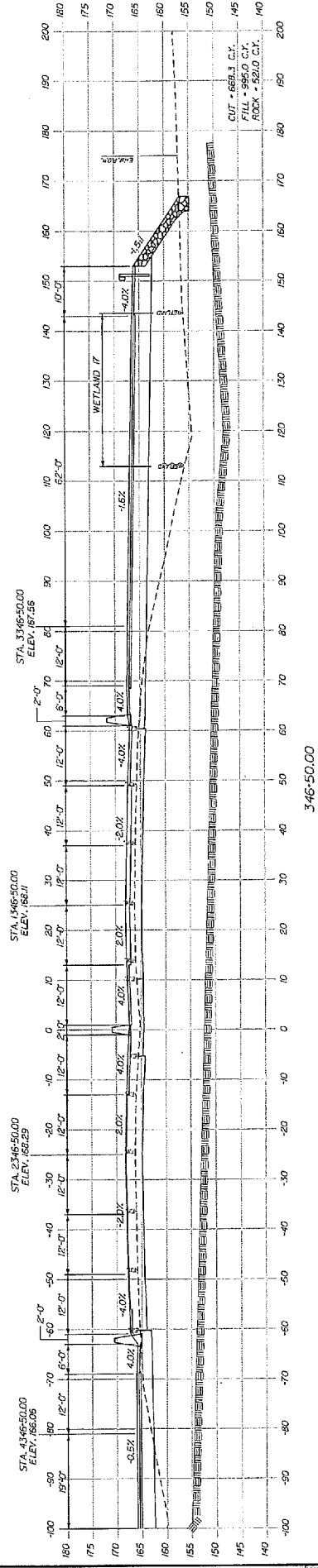

346+50.00

Scale:



Designed by:

No.	Revision	By	Date

DESIGNED	BY	DATE
CHECKED	BY	DATE
IN CHARGE	BY	DATE

JACOBS ENGINEERING GROUP
 343 CONGRESS STREET
 BOSTON, MA 02210
 TEL (617) 242-9222
 FAX (617) 242-9824



THE GOLD STAR
 MEMORIAL HIGHWAY

I-95 CROSS SECTIONS
 STA. 346+50

CONTRACT: WIN

SHEET NUMBER: XS-68
 SPSET 3 OF

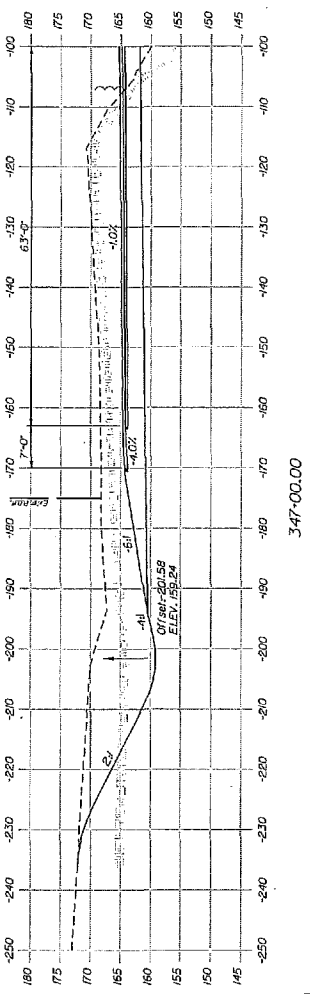

347+00.00

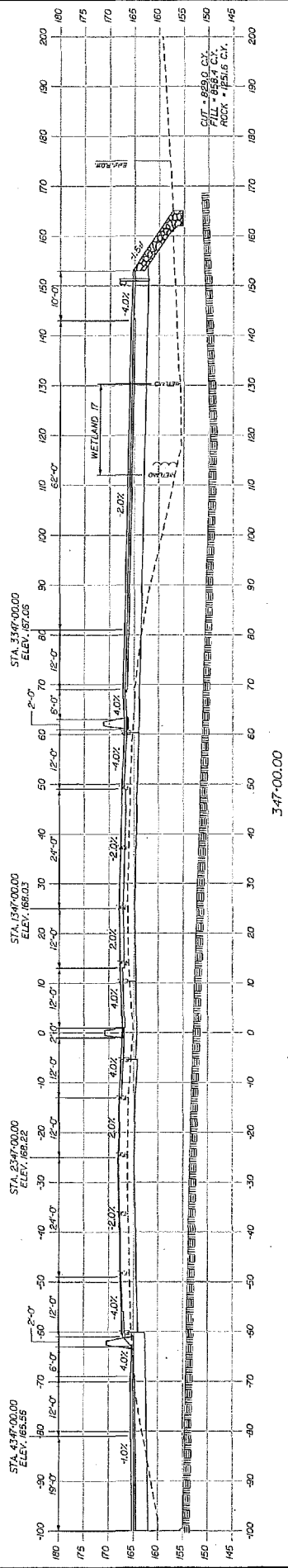

347+00.00



Scale: 1" = 20'

Designed by:

Project Manager:

JACOBS ENGINEERING GROUP
343 CONGRESS STREET
BOSTON, MA 02210
TEL (617) 242-9222
FAX (617) 242-9824



THE GOLD STAR
MEMORIAL HIGHWAY

CONTRACT: WIN

I-95 CROSS SECTIONS
STA. 347+00

SHEET NUMBER: XS-69
SPS:ETS OF

Date: 11/2/2017

Pathname: \\MSTA\DR\proj\104\sect\197

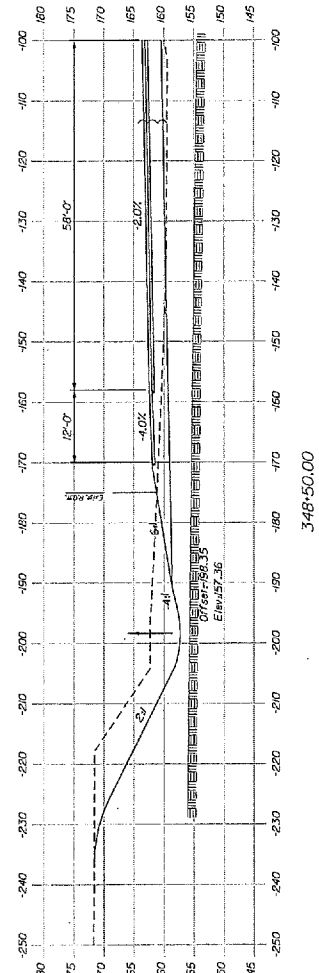

348-50.00

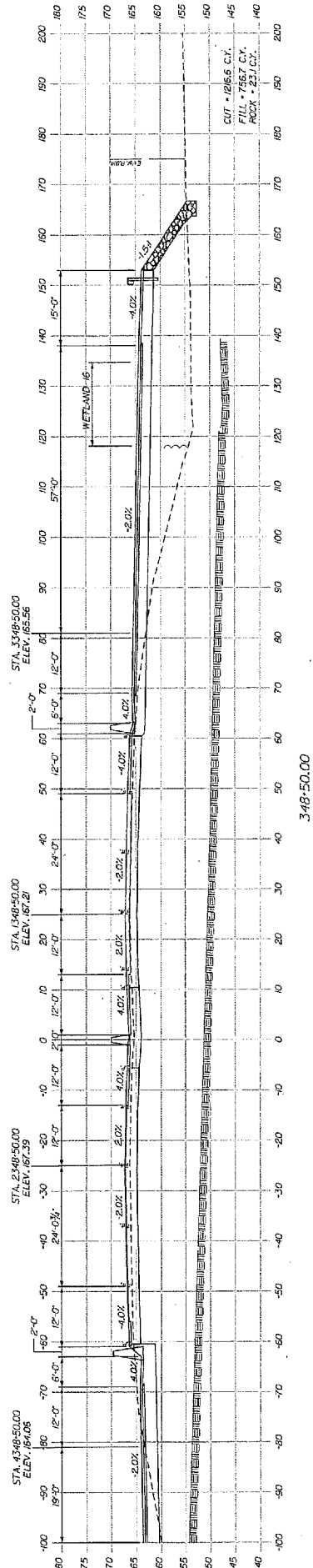

348-50.00

Scale:

No.	Revision	By	Date

Designed by:

Designated	By	Date	Checked	By	Date

CONSULTANT PROJECT MANAGER: PROGRAM MANAGER

JACOBS

JACOBS ENGINEERING GROUP
 343 CONGRESS STREET
 BOSTON, MA 02210
 TEL (617) 242-9222
 FAX (617) 242-9824



**THE GOLD STAR
 MEMORIAL HIGHWAY**

CONTRACT: WIN

MIA PROJECT MANAGER: R. NORWOOD

**I-95 CROSS SECTIONS
 STA. 348+50**

SHEET NUMBER: X5-72
 #PSETS OF

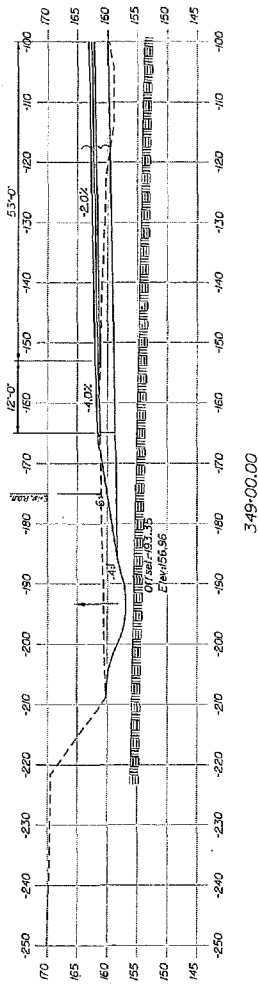

349+00.00

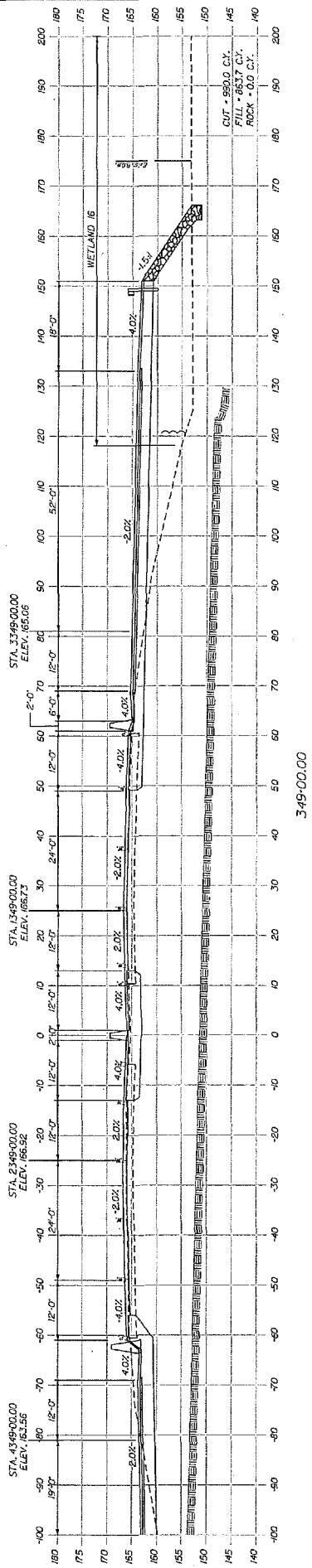

349+00.00

Scale:
0 10 20
Scale of Feet

Designed by:



By	Date	By	Date
AVS	08/16	CSM	08/15
SMG	08/16	Dr. Charles et al.	---

JACOBS ENGINEERING GROUP
343 CONGRESS STREET
BOSTON, MA 02210
TEL (617) 242-5222
FAX (617) 242-5624



THE GOLD STAR
MEMORIAL HIGHWAY

I-95 CROSS SECTIONS
STA. 349+00

CONTRACT: WIN
SHEET NUMBER: XS-73
APSETS: OP

MTA PROJECT MANAGER: R. LORWOOD

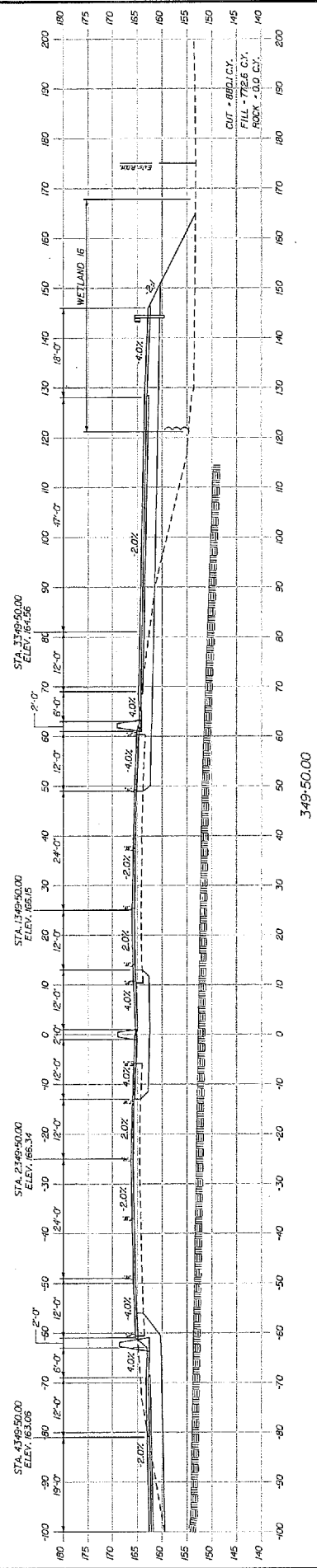
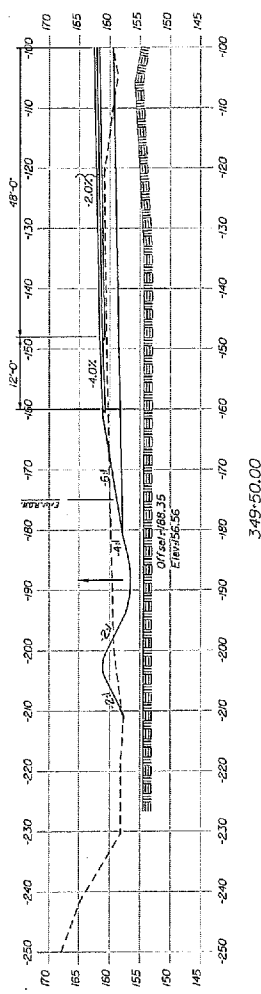

Scale: 1" = 20'
 Scale of P&P

No.	Revision	By	Date

Designed by:

JACOBS

Designed	By	Date	Checked	By	Date
Green	SMG	08/7/6	CSM	---	--/--

JACOBS ENGINEERING GROUP
 343 CONGRESS STREET
 BOSTON, MA 02210
 TEL 617/724-9222
 FAX 617/724-9224



**THE GOLD STAR
 MEMORIAL HIGHWAY**

MTA PROJECT MANAGER: R. NORWOOD

I-95 CROSS SECTIONS
 STA. 349+50

SHEET NUMBER: XS-74
 \$PSETS.DF

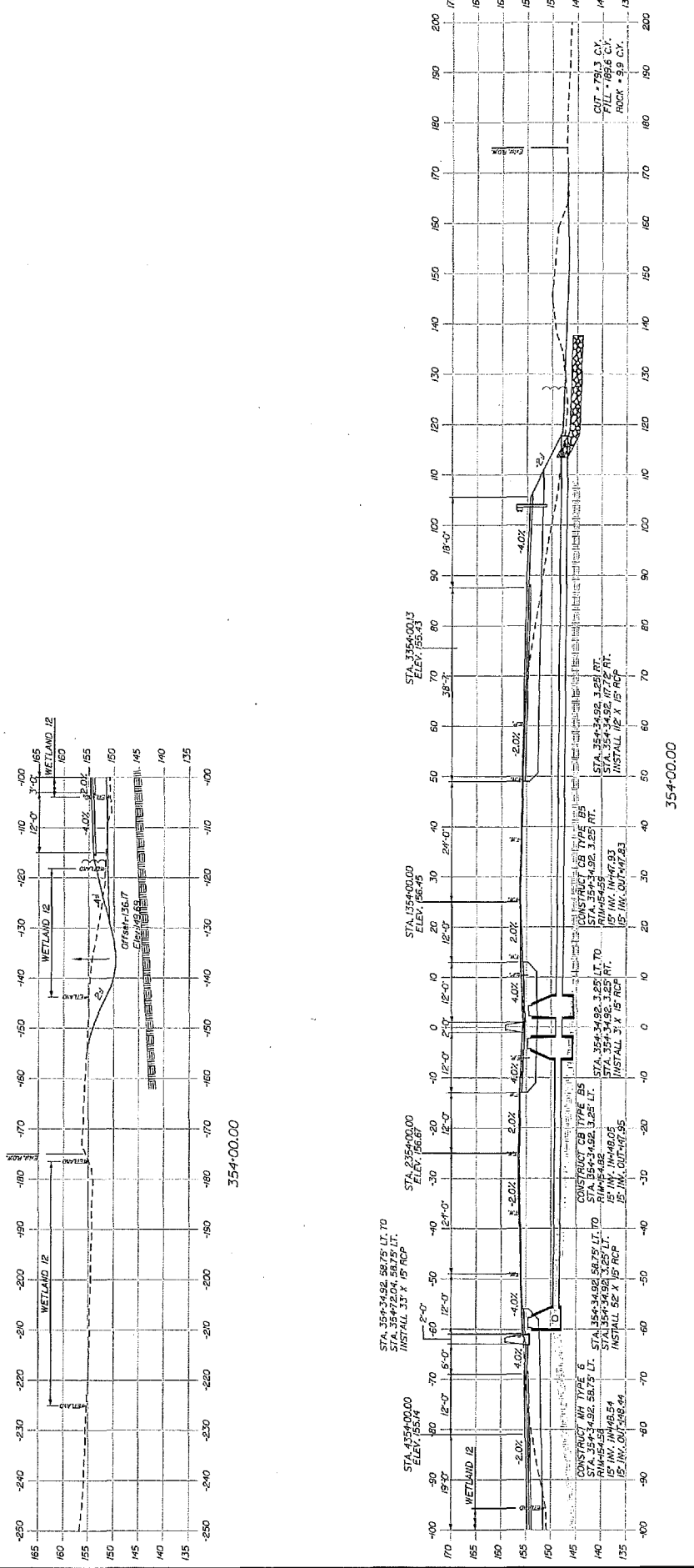

Scale: 1" = 20'

No.	Revision	By	Date

Designed by: _____

Checked: _____

By: _____ Date: _____

Project Manager: _____

Scale: 1" = 20'

JACOBS

JACOBS ENGINEERING GROUP
343 CONGRESS STREET
BOSTON, MA 02210
TEL (617) 242-9222
FAX (617) 242-9824

**THE GOLD STAR
MEMORIAL HIGHWAY**

I-95 CROSS SECTIONS
STA. 354+00

CONTRACT: WIN

MTA PROJECT MANAGER: R. HURWOOD

SHEET NUMBER: XS-83
PAGE 3 OF 3

Date: 12/20/17

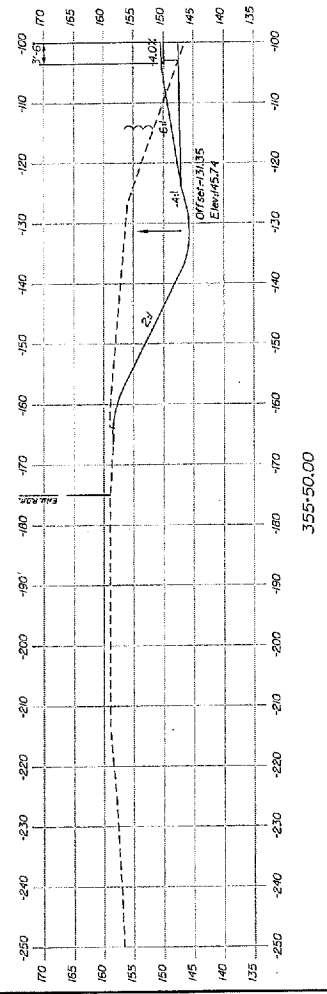

355+50.00

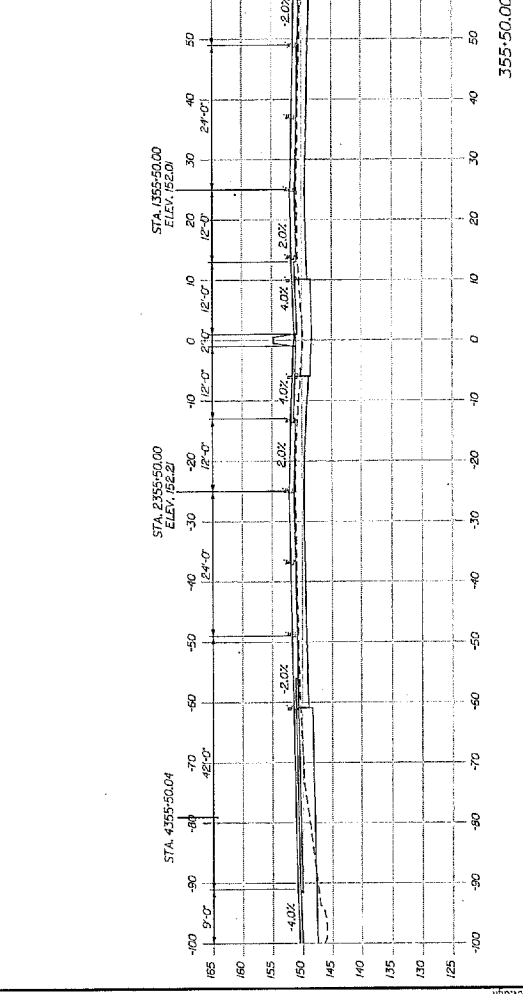

355+50.00

Scale: 1" = 20' 0" 20'

Designed by:

No.	Revision	By	Date

JACOBS

JACOBS ENGINEERING GROUP
343 CONGRESS STREET
BOSTON, MA 02210
TEL (617) 242-9222
FAX (617) 242-9624



**THE GOLD STAR
MEMORIAL HIGHWAY**

I-95 CROSS SECTIONS
STA. 355+50

CONTRACT: WIN

MIA PROJECT MANAGER: R. NORWOOD

SHEET NUMBER: X-5-B6
OF SETS: 6

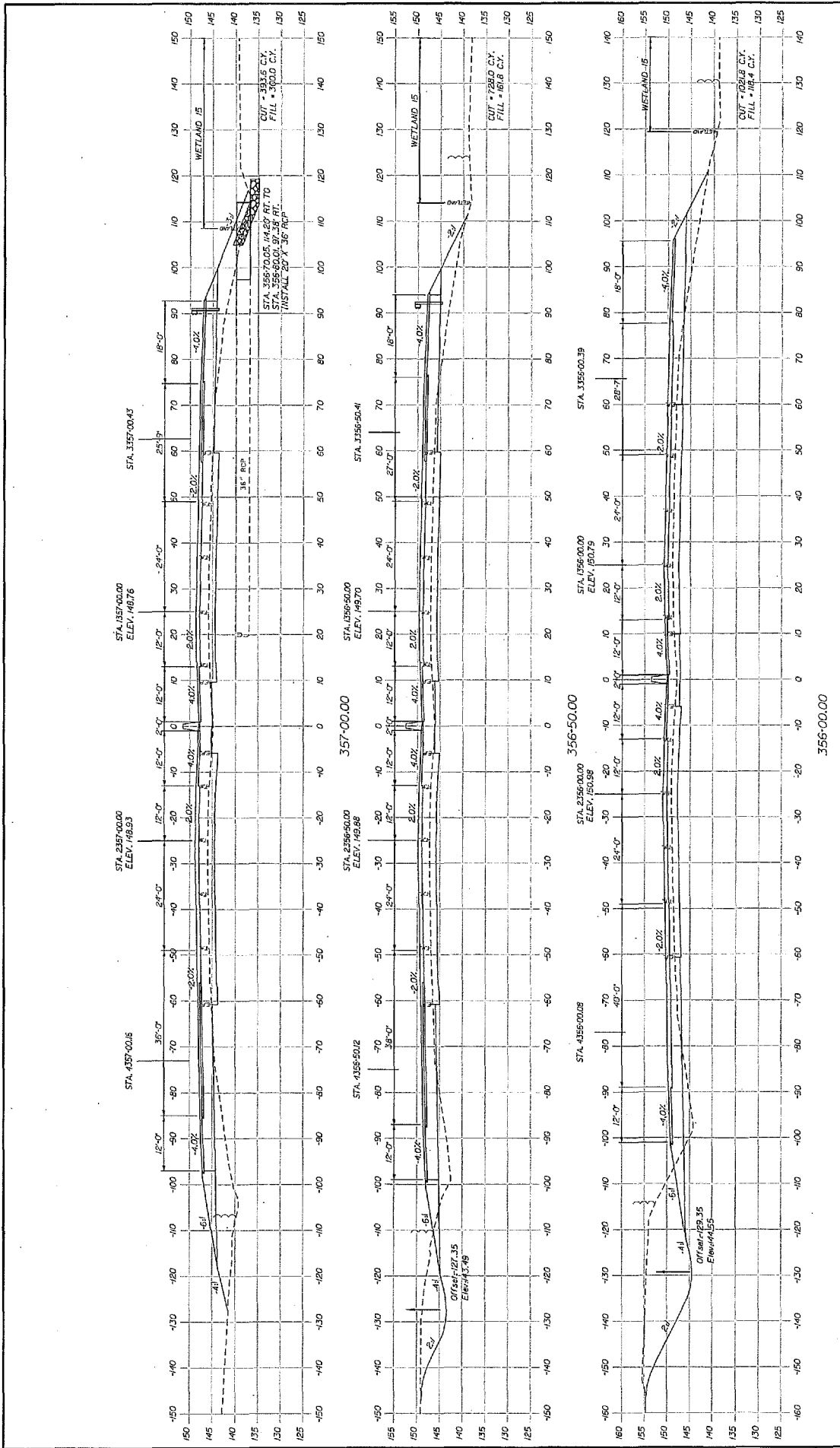

Scale:

No.	Revision	By	Date

Designed by: _____

Checked	By	Date

CONSULTANT PROJECT MANAGER: PROJECT MANAGER

Checked	By	Date

Checked: _____

Checked	By	Date

Checked: _____

IN CHARGE OF: _____

DATE: 05/19/18

PROJECT: I-95

CONTRACT: WIN

SHEET NUMBER: XS-87

OF SET: 3 OF

CONTRACT: WIN

WTA PROJECT MANAGER: B. NORWOOD

THE GOLD STAR MEMORIAL HIGHWAY

I-95 CROSS SECTIONS
STA. 356+00 TO STA. 357+00

JACOBS ENGINEERING GROUP
343 CONGRESS STREET
BOSTON, MA 02210
TEL (617) 242-9222
FAX (617) 242-9874

MAINT. TURNPIKE

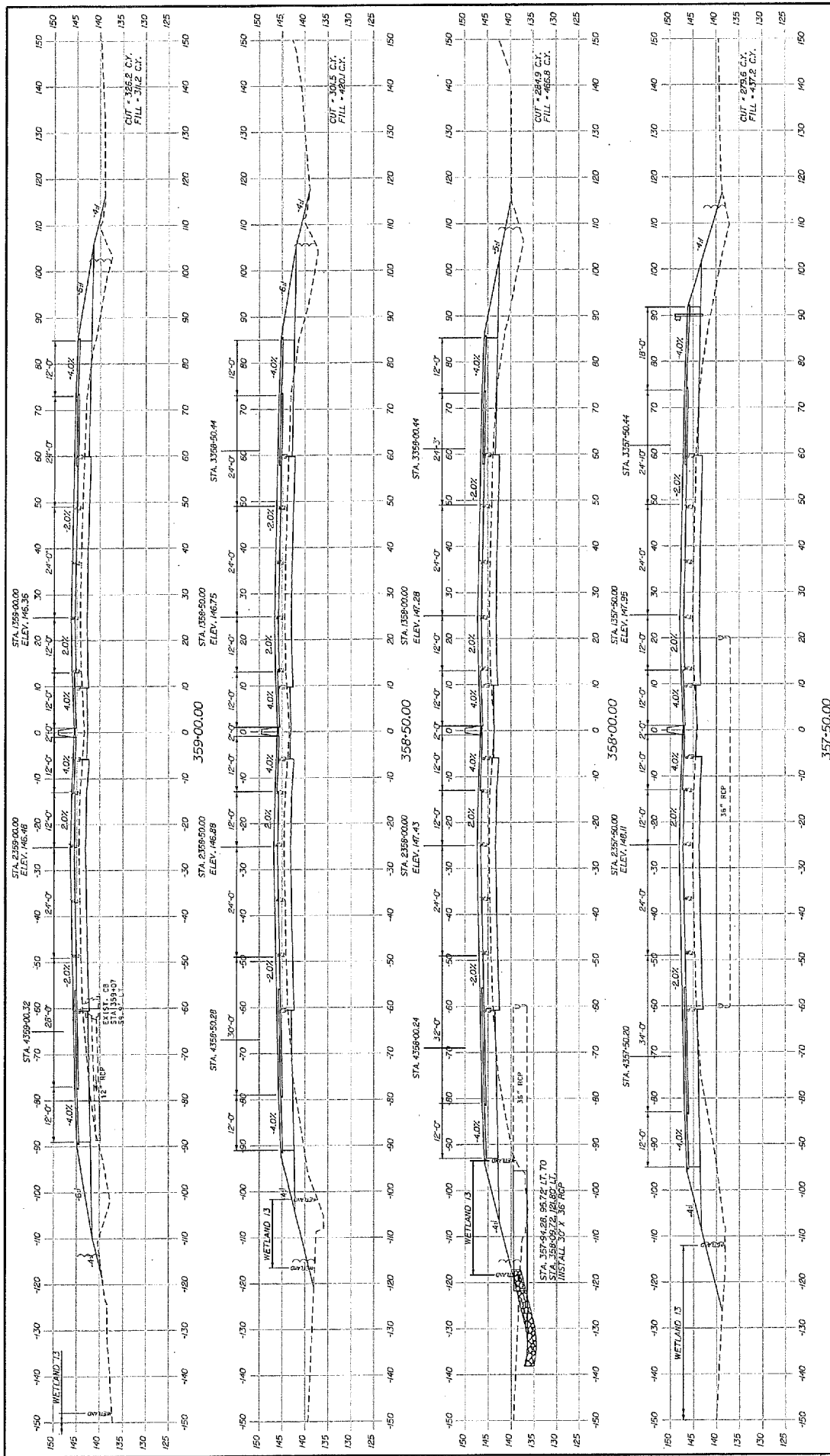

Scale:

No.	Revision	By	Date

Designed by: _____

Checked	By	Date

CONTRACT NUMBER: XS-88
SHEET NUMBER: XS-88
PROJECT NUMBER: XS-88

THE GOLD STAR
MEMORIAL HIGHWAY

1-95 CROSS SECTIONS
STA. 357+50 TO STA. 359+00

JACOBS ENGINEERING GROUP
343 CONGRESS STREET
BOSTON, MA 02210
TEL (617) 242-8222
FAX (617) 242-8624

MTA PROJECT MANAGER: R. NORWOOD

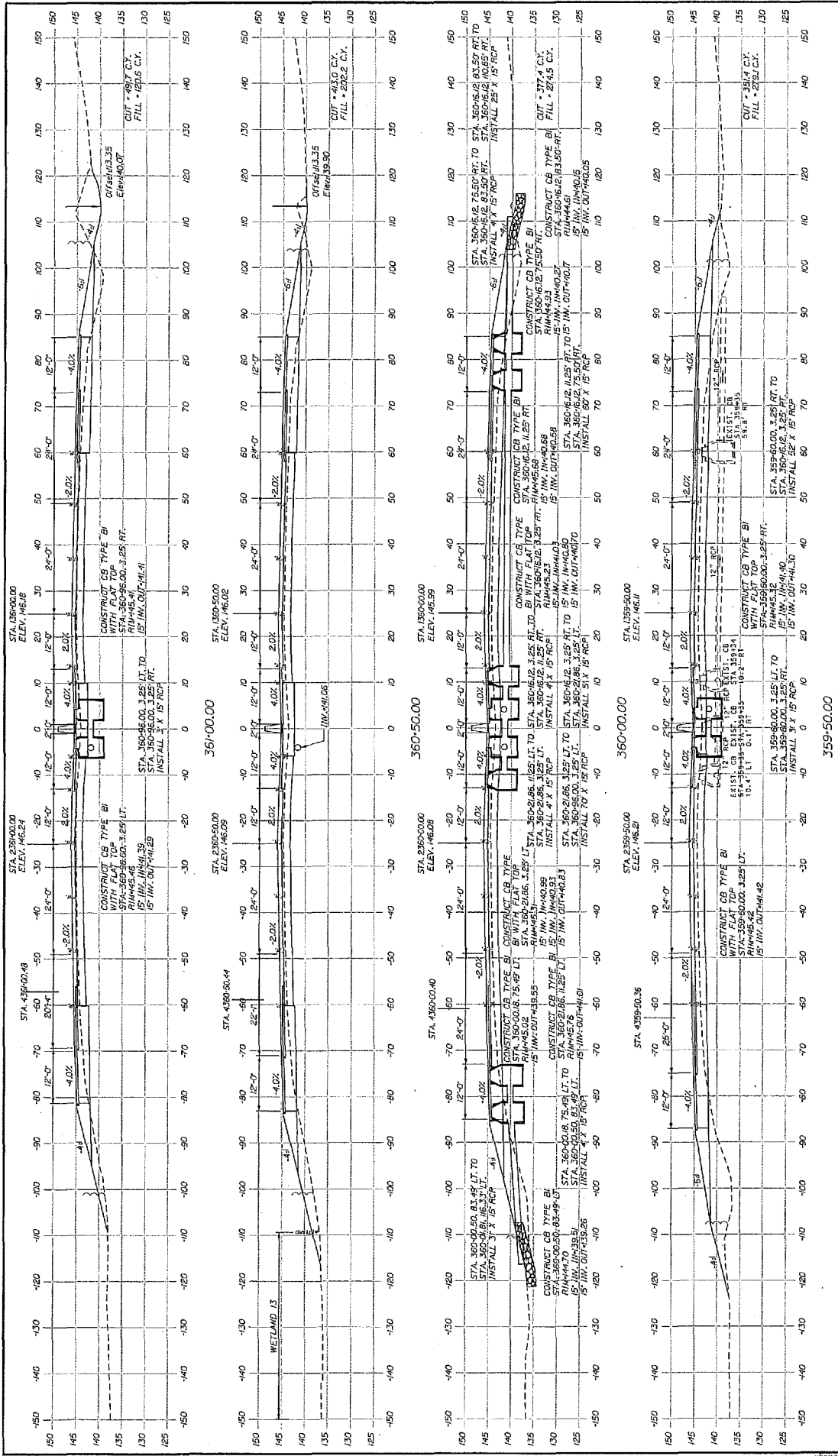

Scale: 1" = 20' (Scale of Feet)

No.	Revised	By	Date

Designed by: [Signature] Date: 08/16/16
 Drawn by: [Signature] Date: 08/16/16
 In Charge of: [Signature] Date: 08/16/16

CONSULTANT PROJECT MANAGER: PRO/MANAGERS
 By: [Signature] Date: 08/16/16
 Checked: [Signature] Date: 08/16/16
 In Charge of: [Signature] Date: 08/16/16

Designed by: [Signature] Date: 08/16/16
 Drawn by: [Signature] Date: 08/16/16
 In Charge of: [Signature] Date: 08/16/16

THE GOLD STAR MEMORIAL HIGHWAY
 I-95 CROSS SECTIONS
 STA. 359+50 TO STA. 361+00
 CONTRACT: WIN
 WTA PROJECT MANAGER: P. NORWOOD
 SHEET NUMBER: XS-89
 9P-SECT-10.P

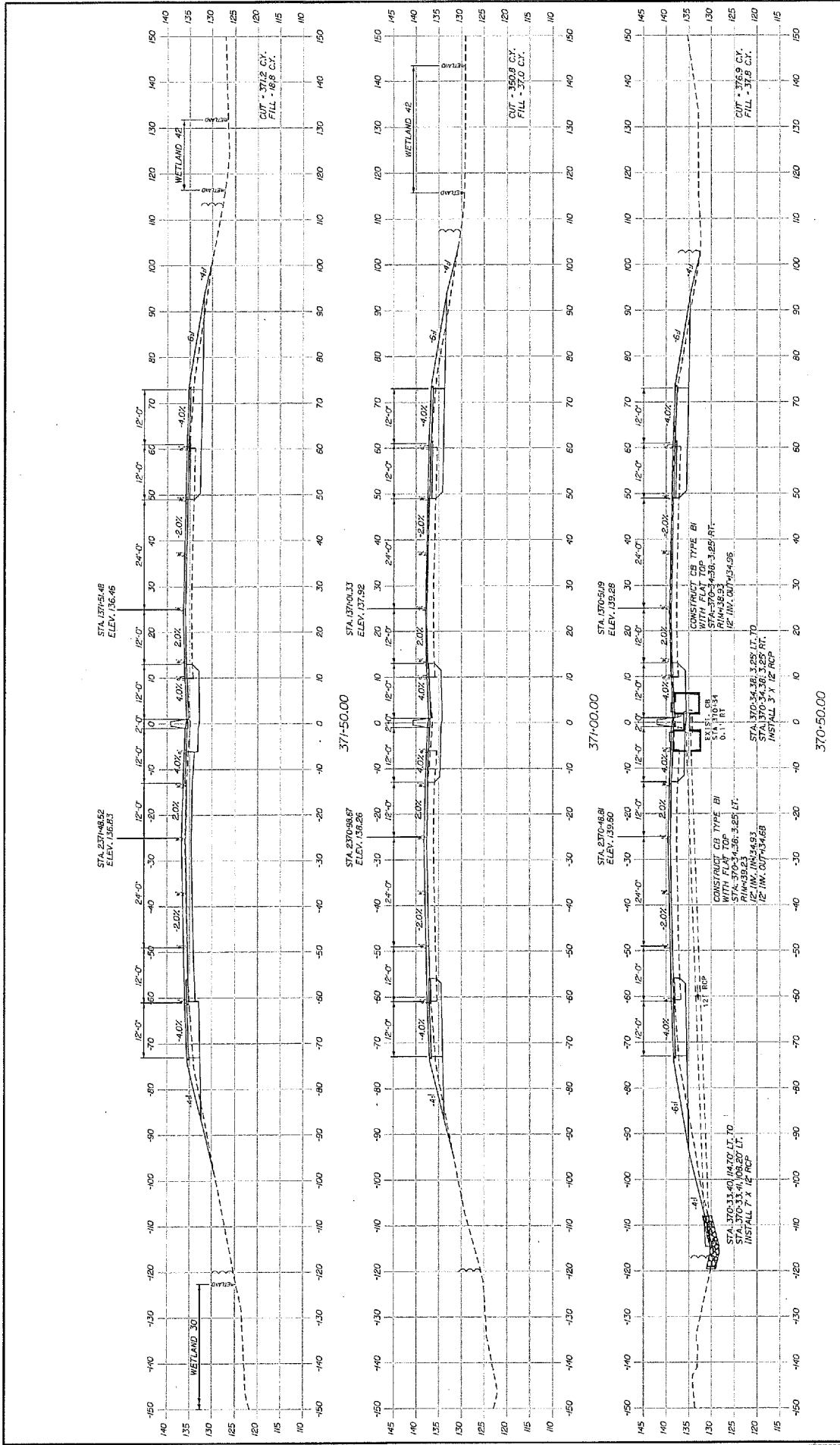

**THE GOLD STAR
MEMORIAL HIGHWAY**

I-95 CROSS SECTIONS
STA. 370+50 TO STA. 371+50

CONTRACT NUMBER: XS-96
SHEETS OF 8
CONTRACT-WIN

MVA PROJECT MANAGER: R. NORWOOD

JACOBS ENGINEERING GROUP
34.3 CONGRESS STREET
BOSTON, MA 02210
TEL (617) 242-9222
FAX (617) 242-9824

JACOBS

Designed by: _____

Scale:	0	20	40	60	80	100	120	140	160	180	200
	Feet										
	1" = 40'										
No.	By	Date									
Revised											
Described	By	Date									
Drawn	By	Date									
Checked	By	Date									
In Charge of	By	Date									
PROJECT MANAGER	By	Date									
CONSULTANT	By	Date									

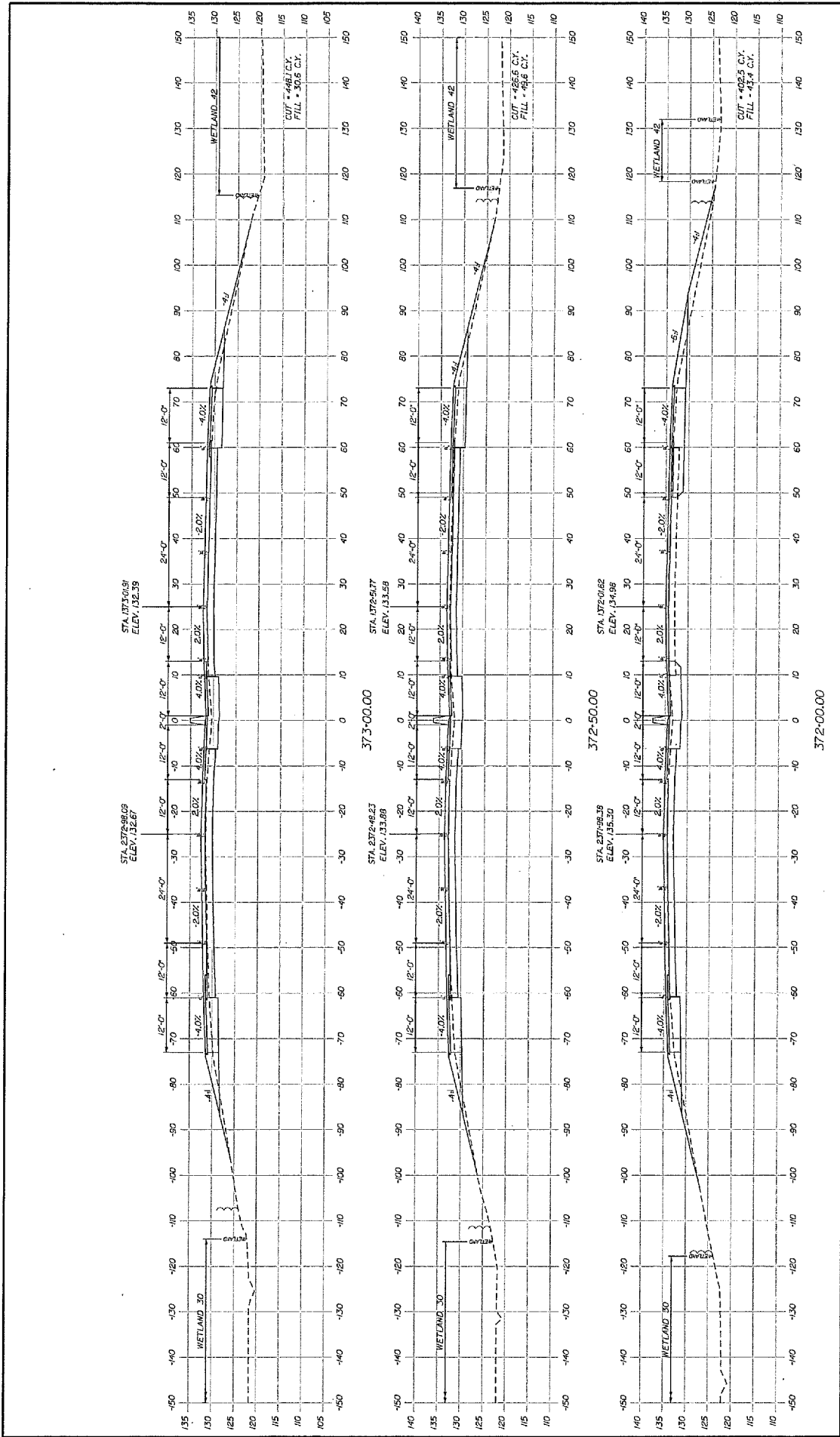

Scale: 1" = 20'

Revision: _____

By: _____ Date: _____

Checked: _____ Date: _____

Design: _____ Date: _____

Drawn: _____ Date: _____

Project Manager: _____

Project Engineer: _____

Project Surveyor: _____

Project Inspector: _____

Project Assistant: _____

Project Clerk: _____

Project Office: _____

Project Address: _____

Project Phone: _____

Project Fax: _____

Project Email: _____

Project Website: _____

Project Logo:

THE GOLD STAR MEMORIAL HIGHWAY

1-95 CROSS SECTIONS
STA. 372+00 TO STA. 373+00

CONTRACT-WIN

SHEET NUMBER: XS-97

PROJECT OF

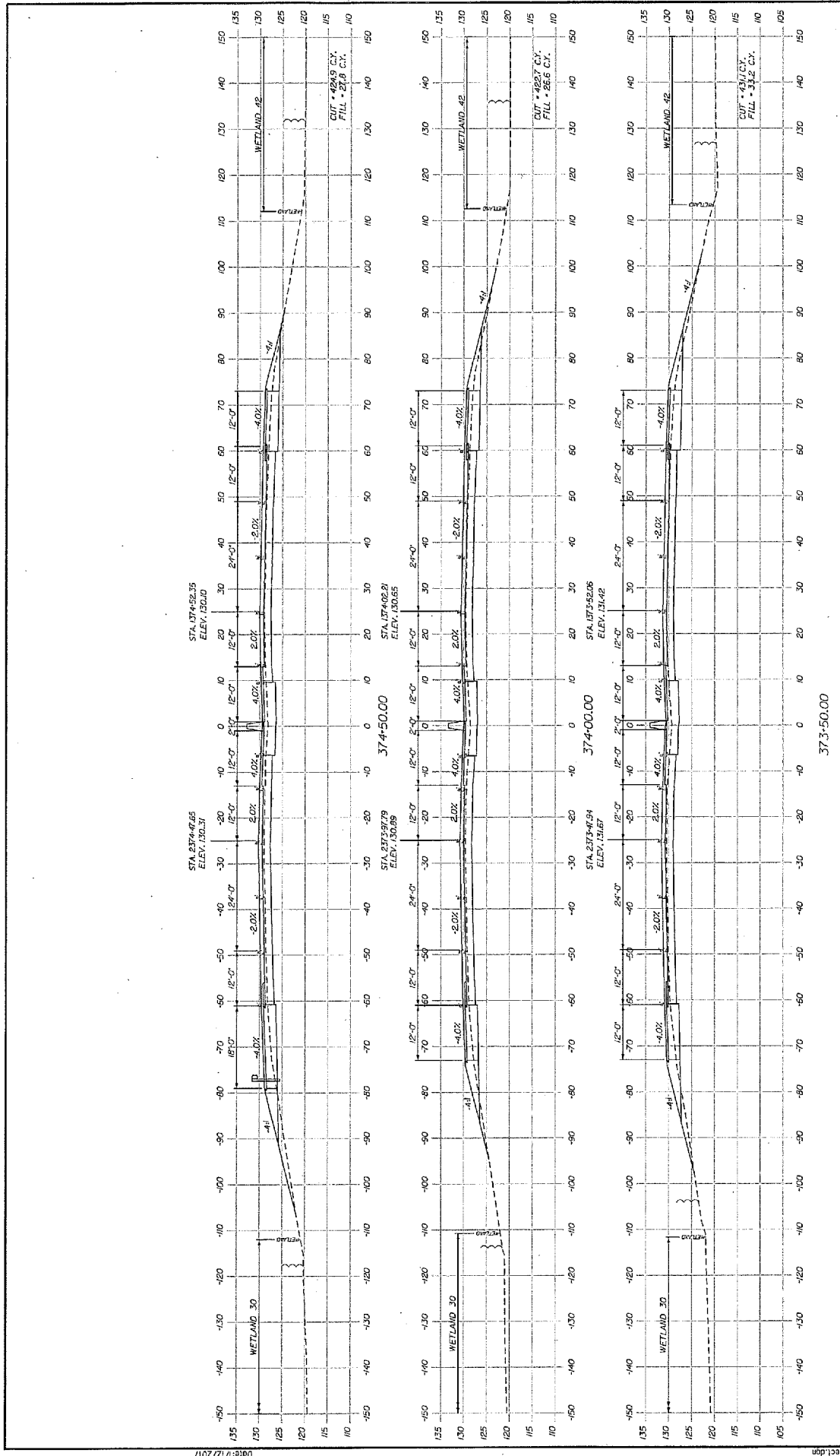

373+50.00

Scale: 1" = 20'

Revised: _____

By: _____

Date: _____

Designed by: _____

Checked: _____

Drawn: _____

In. Charge of: _____

By: _____

Date: _____

CSM: _____

AMS: _____

SMC: _____

JACOBS

CONSULTANT PROJECT MANAGER: PROGRAM MANAGERS

JACOBS ENGINEERING GROUP
 343 CONGRESS STREET
 BOSTON, MA 02210
 TEL (617) 242-9222
 FAX (617) 242-9224

**THE GOLD STAR
 MEMORIAL HIGHWAY**

MTA PROJECT MANAGER: R. MORWOOD

I-95 CROSS SECTIONS
 STA. 373+50 TO STA. 374+50

SHEET NUMBER: X5-98
 OF 5 SHEETS

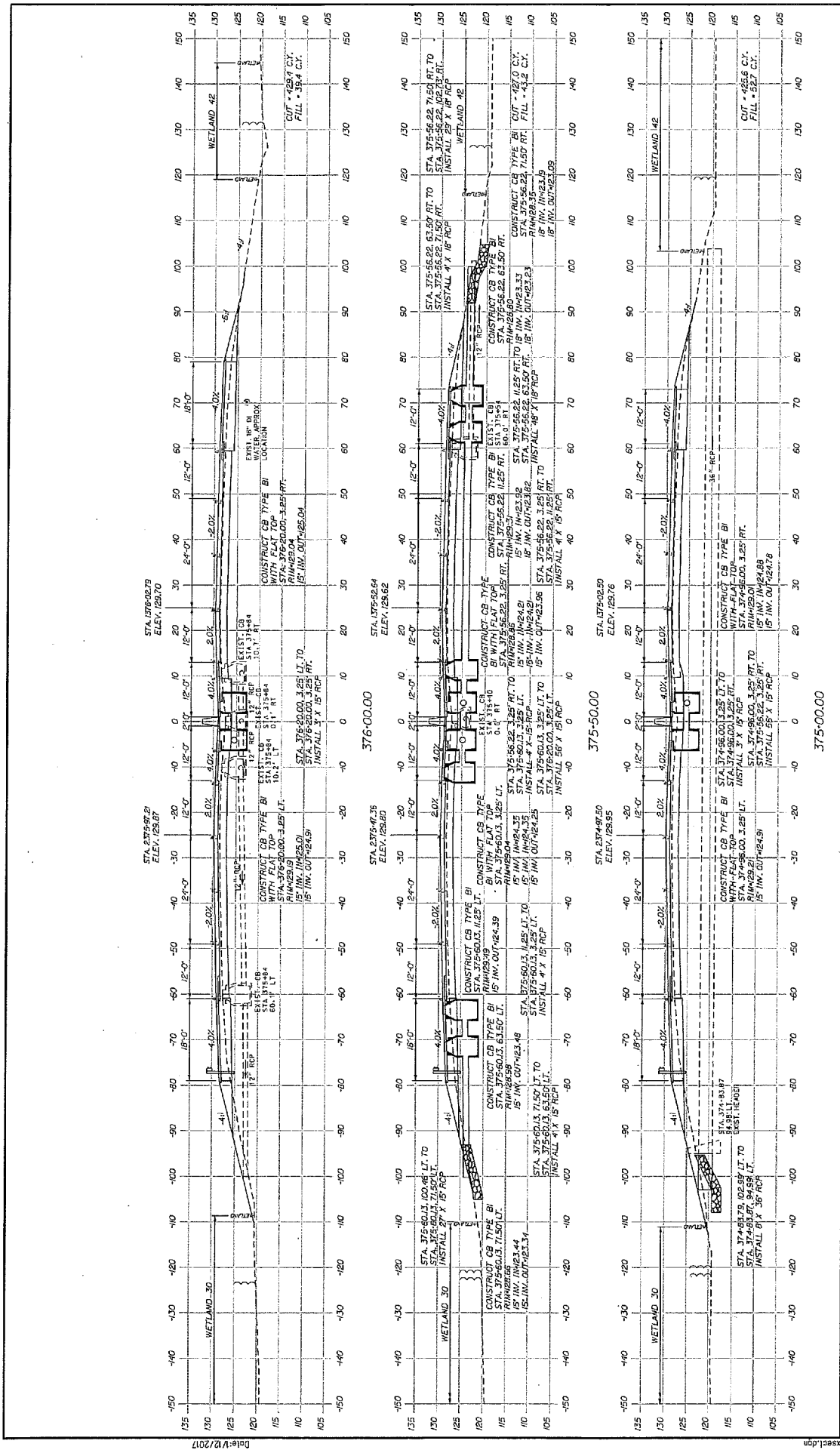

**THE GOLD STAR
MEMORIAL HIGHWAY**

I-95 CROSS SECTIONS
STA. 375+00 TO STA. 376+00

SHEET NUMBER: XS-99
9-PSETS OF

CONTRACT: WIN

MTA PROJECT MANAGER: R. NORWOOD

JACOBS ENGINEERING GROUP
543 CORCORAN STREET
BOSTON, MA 02210
TEL (617) 242-9222
FAX (617) 242-9824

MAINE
MULTIPLY

Scale: 1" = 20'

No.	By	Date	Checked	By	Date
	AMS	08/15		CSM	08/16
	SMG	08/16			

Designed by: _____

Consultant Project Manager: _____

Drawn: _____

Checked: _____

By: _____

Date: _____

In Charge: _____

Scale of Plan: _____

Revision: _____

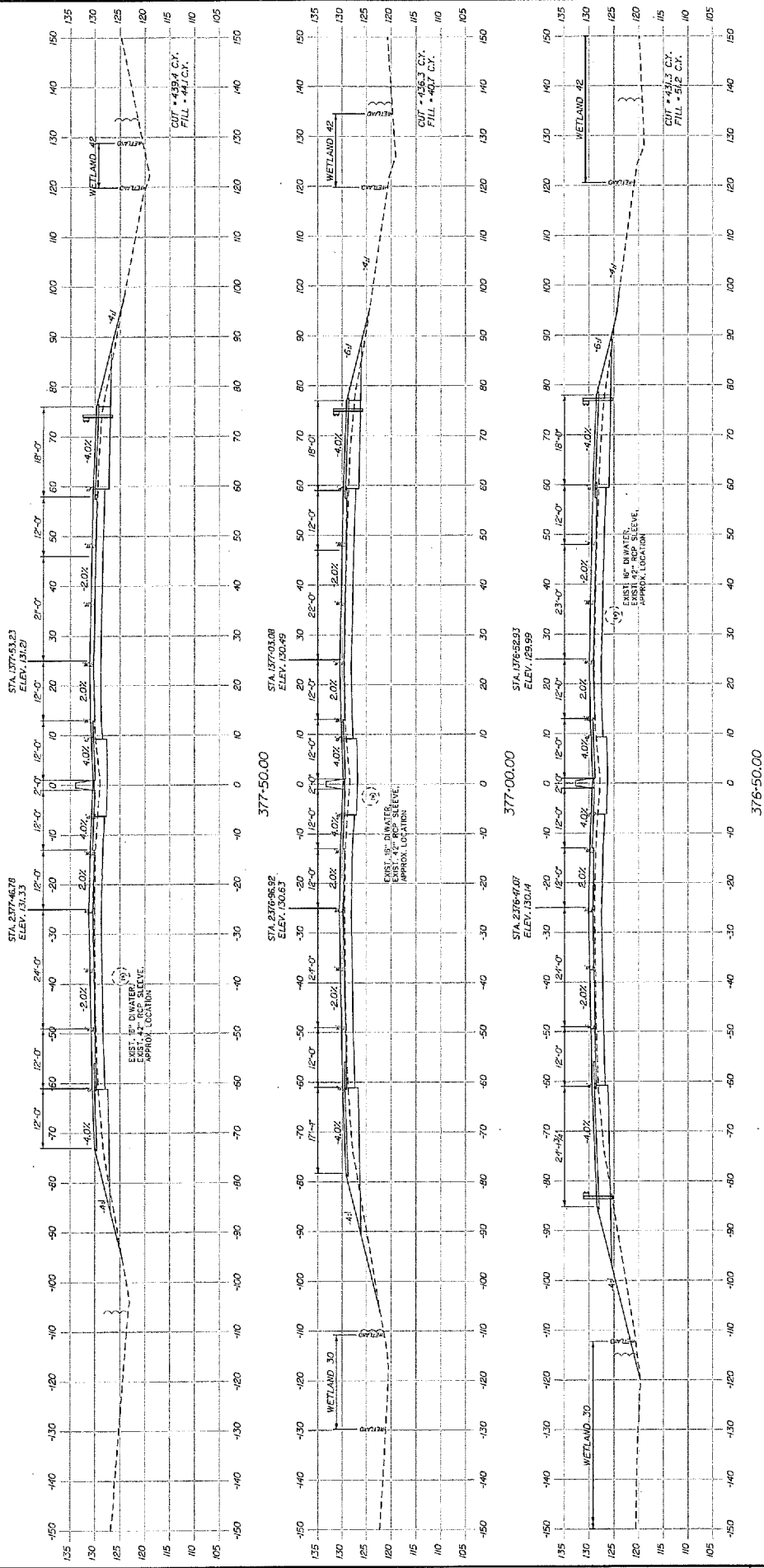

Date: 11/2/2011

Scale:

No.	Revision	By	Date

Designed by:

JACOBS

CONSULTANT PROJECT MANAGER: PROGRAMMERS

By	Date	By	Date
DESIGNED	08/16	CHECKED	08/16
DRAWN	08/16	IN CHARGE	08/16

JACOBS ENGINEERING GROUP
 343 CONGRESS STREET
 BOSTON, MA 02210
 TEL (617) 242-9222
 FAX (617) 242-9824



**THE GOLD STAR
 MEMORIAL HIGHWAY**

MTA PROJECT MANAGER: R. BURNWOOD

I-95 CROSS SECTIONS
 STA. 376+50 TO STA. 377+50

SHEET NUMBER: XS-100
 SPSET13.0F

CONTRACT-WIN

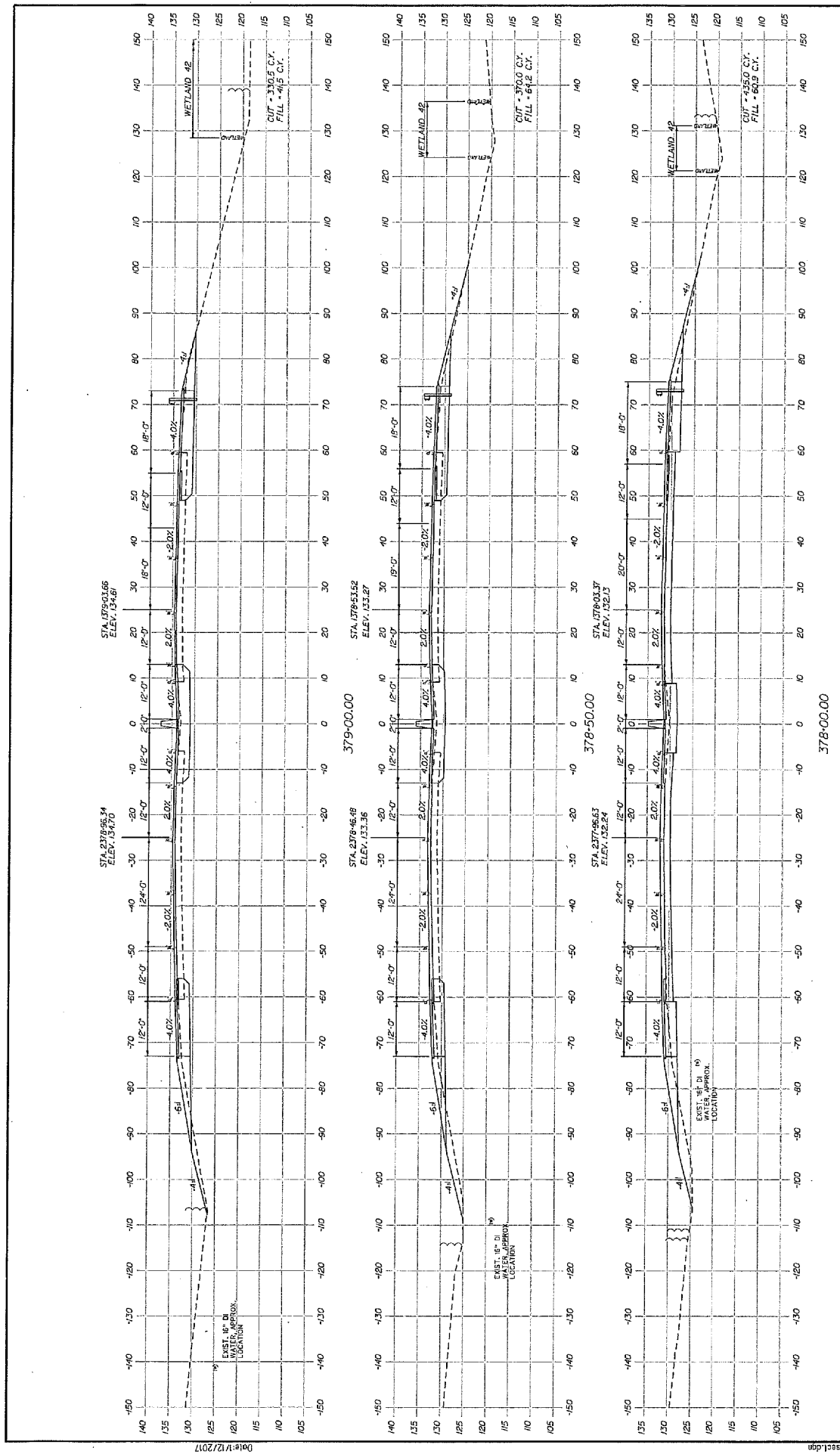

Scale:

No.	Revision	By	Date

Designed by: _____

Consultant	Project Manager	Program Manager
By: _____	By: _____	By: _____
Date: _____	Date: _____	Date: _____
Checked: _____	Checked: _____	Checked: _____
Drawn: _____	In Charge of: _____	

JACOBS

JACOBS ENGINEERING GROUP
 333 CONGRESS STREET
 BOSTON, MA 02210
 TEL (617) 242-9222
 FAX (617) 242-9824

THE GOLD STAR MEMORIAL HIGHWAY

MTA PROJECT MANAGER: R. NORWOOD

I-95 CROSS SECTIONS
 STA. 378+00 TO STA. 379+00

CONTRACT: WIN
 SHEET NUMBER: XS-101
 #PSETS OF

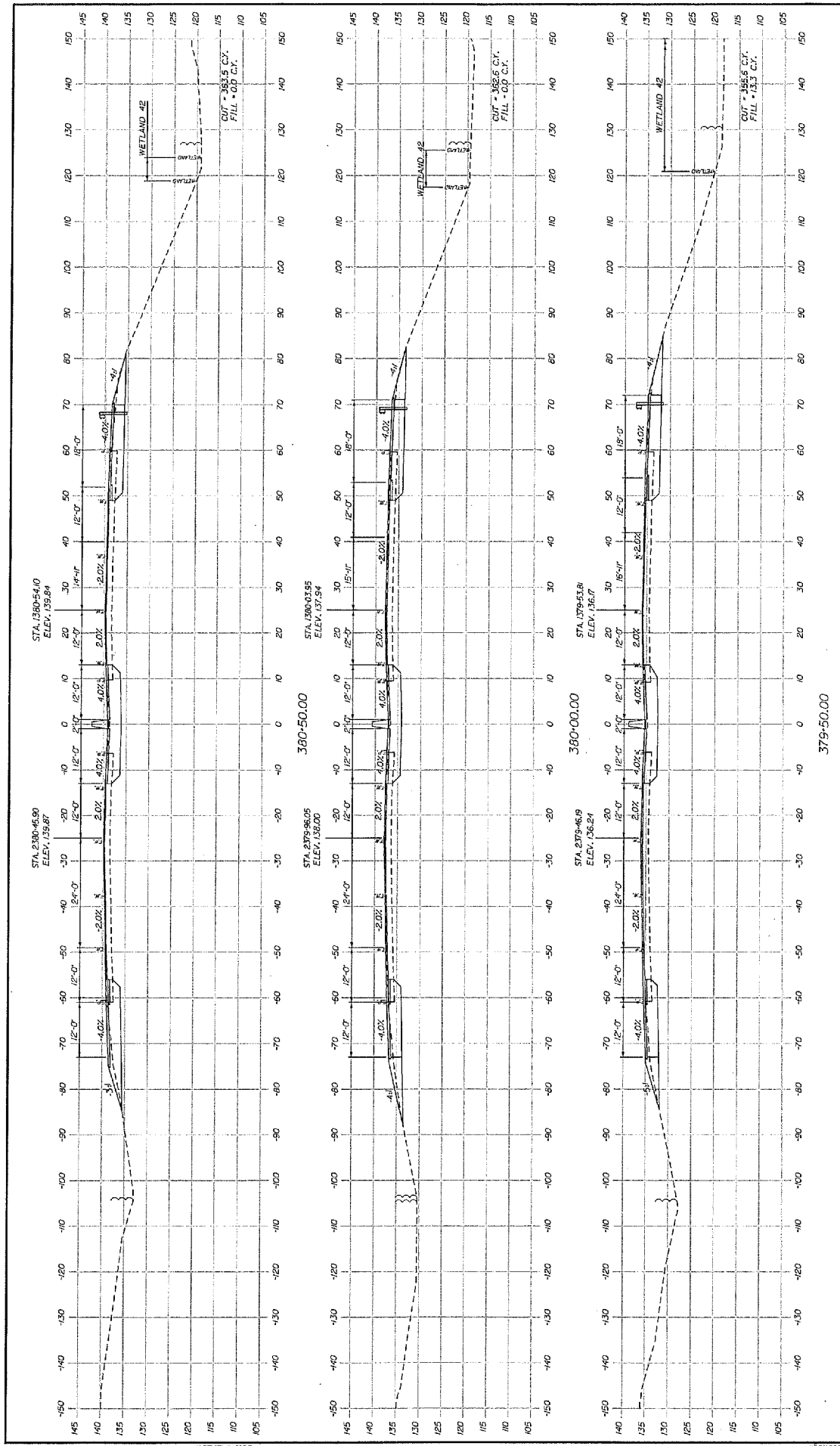

THE GOLD STAR
MEMORIAL HIGHWAY

1-95 CROSS SECTIONS
STA. 379+50 TO STA. 380+50

SHEET NUMBER: XS-102
SPSSETS OF

CONTRACT: WIN

MTA PROJECT MANAGER: R. NORWOOD

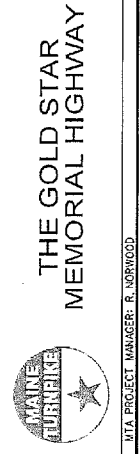

JACOBS ENGINEERING GROUP
343 CONGRESS STREET
BOSTON, MA 02210
TEL (617) 242-8222
FAX (617) 242-9024

Designed by:

JACOBS

CONSULTANT PROJECT MANAGER: JPROJMANAGER

By	Date	Rev	Date
AMS	08/16	1	08/16
AMS	08/16	2	08/16

Drawn: In Charge of

Scale: 1" = 20'

Revision:

No.	By	Date

File Name: \\MS1A\DR\proj\sect\plan

Date: 1/12/2017

From: M:\15A\RP\15a-rp\15a-rp-section.dwg

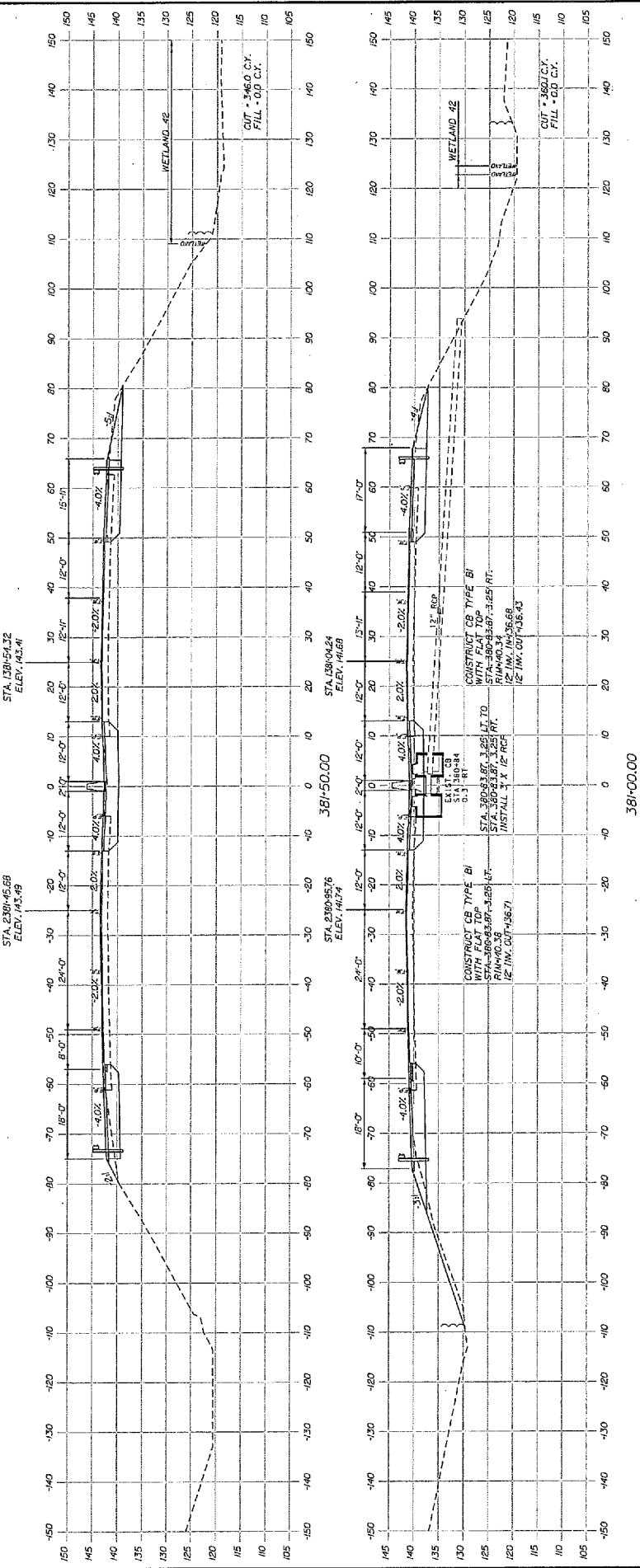

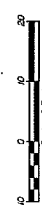
		<p>THE GOLD STAR MEMORIAL HIGHWAY</p>		<p>1-95 CROSS SECTIONS STA. 381+00 TO STA. 381+50</p>	
<p>JACOBS ENGINEERING GROUP 300 BOSTON AVENUE BOSTON, MA 02116 TEL (617) 242-9222 FAX (617) 242-9824</p>		<p>MTA PROJECT MANAGER: R. HIGWOOD</p>		<p>CONTRACTOR: [Blank]</p>	
<p>Designed by: [Blank]</p>		<p>Scale: </p>		<p>SHEET NUMBER: XS-103 SPS: 1 OF 5</p>	
<p>CONSULTANT PROJECT MANAGER: [Blank]</p>		<p>By: [Blank] Date: [Blank]</p>		<p>By: [Blank] Date: [Blank]</p>	
<p>Designed: [Blank]</p>		<p>Checked: [Blank]</p>		<p>In Charge of: [Blank]</p>	
<p>Drawn: [Blank]</p>		<p>Checked: [Blank]</p>		<p>In Charge of: [Blank]</p>	

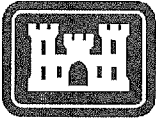

**US Army Corps
of Engineers** ®
New England District

(Minimum Notice: Permittee must sign and return notification
within one month of the completion of work.)

COMPLIANCE CERTIFICATION FORM

Permit Number: NAE-2007-01211

Project Manager Clement

Name of Permittee: Maine Turnpike Authority

Permit Issuance Date: _____

Please sign this certification and return it to the following address upon completion of the activity and any mitigation required by the permit. You must submit this after the mitigation is complete, but not the mitigation monitoring, which requires separate submittals.

 * MAIL TO: U.S. Army Corps of Engineers, New England District *
 * Permits and Enforcement Branch C *
 * Regulatory Division *
 * 696 Virginia Road *
 * Concord, Massachusetts 01742-2751 *

Please note that your permitted activity is subject to a compliance inspection by an U.S. Army Corps of Engineers representative. If you fail to comply with this permit you are subject to permit suspension, modification, or revocation.

I hereby certify that the work authorized by the above referenced permit was completed in accordance with the terms and conditions of the above referenced permit, and any required mitigation was completed in accordance with the permit conditions.

Signature of Permittee

Date

Printed Name

Date of Work Completion

(_____) _____
Telephone Number

(_____) _____
Telephone Number

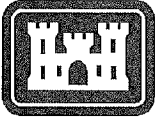

**US Army Corps
of Engineers** ®
New England District

**GENERAL PERMIT
WORK-START NOTIFICATION FORM**
(Minimum Notice: Two weeks before work begins)

* MAIL TO: U.S. Army Corps of Engineers, New England District *
* Permits and Enforcement Branch *
* Regulatory Division *
* 696 Virginia Road *
* Concord, Massachusetts 01742-2751 *

Corps of Engineers Permit No. NAE-2007-01211 was issued to the Maine Turnpike Authority on . This work is located in wetlands adjacent to the Maine Turnpike, in the vicinity of Mile 8.8, at York, Maine. The permit authorized the permittee to fill approximately 58,086 s.f. of freshwater wetlands in order to construct a replacement for the existing deteriorated and deficient York Toll Plaza.

The people (e.g., contractor) listed below will do the work, and they understand the permit's conditions and limitations.

PLEASE PRINT OR TYPE

Name of Person/Firm: _____

Business Address: _____

Telephone Numbers: () _____ () _____

Proposed Work Dates: Start: _____ Finish: _____

Permittee/Agent Signature: _____ **Date:** _____

Printed Name: _____ **Title:** _____

Date Permit Issued: _____ **Date Permit Expires:** _____

FOR USE BY THE CORPS OF ENGINEERS

PM: Clement **Submittals Required:** Yes

Inspection Recommendation: Inspect as convenient

(This page left intentionally blank)

APPENDIX K

USACE MAINE GENERAL PERMIT

(This page left intentionally blank)

**DEPARTMENT OF THE ARMY
GENERAL PERMIT FOR
THE STATE OF MAINE**

The New England District of the U.S. Army Corps of Engineers (Corps) hereby issues a General Permit (GP) for activities subject to Corps jurisdiction in waters of the U.S. within the boundaries of the State of Maine. This GP is issued in accordance with Corps regulations at 33 CFR 320 - 332 [see 33 CFR 325.2(e)(2)]. This GP authorizes activity-specific categories of work that are similar in nature and cause no more than minimal individual and cumulative adverse environmental impacts. Refer to Page 2 for the list of activities and Appendix A for activity specific conditions of eligibility in inland and tidal waters.

I. GENERAL CRITERIA

1. In order for activities to qualify for this GP, they must meet the GP's terms and eligibility criteria (Pages 1–4), General Conditions (GC) (Pages 5 – 20), and Appendix A - Definition of Categories.
2. Under this GP, projects may qualify for the following:
 - Category 1: Category 1 Self -Verification Notification Form is required (SVNF – see Appendix B).
 - Category 2: Application to and written approval from the Corps is required (Pre-Construction Notification (PCN)). No work may proceed until written approval from the Corps is received.

If your project is ineligible for Category 1, it may qualify for Category 2 or an Individual Permit and you must submit an application (see Page 3). The thresholds for activities eligible for Categories 1 and 2 are defined in Appendix A. This GP does not affect the Corps Individual Permit review process or activities exempt from Corps regulation.

3. Prospective permittees need to read:
 - a. Section II to determine if the activity requires Corps authorization.
 - b. Sections III and IV to determine if the activity may be eligible for authorization under this GP, specifically whether it is eligible for Self-Verification (SV) or whether Pre-Construction Notification (PCN) is required.
4. Permittees must ensure compliance with all applicable General Conditions in Section IV. The Corps will consider unauthorized any activity requiring Corps authorization if that activity is under construction or completed and does not comply with all of the terms and conditions.
5. Project proponents are encouraged to contact the Corps with questions at any time. Pre-application meetings (see 33 CFR 325.1(b)), whether arranged by the Corps or requested by permit applicants, are encouraged to facilitate the review of projects. Pre-application meetings and/or site visits can help streamline the permit process by alerting the applicant to potentially time-consuming concerns that are likely to arise during the evaluation of their project (e.g., avoidance, minimization and compensatory mitigation requirements, historic properties, endangered species, essential fish habitat, and dredging contaminated sediments).

II. CORPS JURISDICTION/ACTIVITIES COVERED

1. Permits are required from the Corps of Engineers for the following work:

a. The construction of any structure in, over or under any navigable water of the United States (U.S.)¹, the excavating or dredging from or depositing of material in such waters, or the accomplishment of any other work affecting the course, location, condition, or capacity of such waters. The Corps regulates these activities under Section 10 of the Rivers and Harbors Act of 1899. See 33 CFR 322;

b. The discharge of dredged or fill material and certain discharges associated with excavation into waters of the U.S. (e.g. sidcasting). The Corps regulates these activities under Section 404 of the Clean Water Act (CWA). See 33 CFR 323; and

c. The transportation of dredged material for the purpose of disposal in the ocean. The Corps regulates these activities under Section 103 of the Marine Protection, Research and Sanctuaries Act. See 33 CFR 324.

2. Related laws:

33 CFR 320.3 includes a list of related laws, including: Section 401 of the CWA, Section 402 of the CWA, Section 307(c) of the Coastal Zone Management (CZM) Act of 1972, The National Historic Preservation Act of 1966, the Endangered Species Act, the Fish and Wildlife Act of 1956, the Marine Mammal Protection Act of 1972, Magnuson-Stevens Act, and Section 7(a) of the Wild and Scenic Rivers Act.

3. An activity listed below may be authorized by this GP only if that activity and the permittee satisfy all of the GP's terms and conditions. Any activity not specifically listed below may still be eligible for the GP; applicants are advised to contact the Corps for a specific eligibility determination. Category 1 and Category 2 eligibility criteria for each activity in both Inland and Tidal waters can be found in Appendix A.

1. Repair, Replacement, Expansion, and Maintenance of Authorized Structures and Fills
2. Moorings
3. Structures, Floats and Lifts
4. Aids to Navigation, and Temporary Recreational Structures
5. Dredging, Disposal of Dredged Material, Beach Nourishment, and Rock Removal and Relocation
6. Discharges of Dredged or Fill Material Incidental to the Construction of Bridges
7. Bank and Shoreline Stabilization
8. Residential, Commercial, Industrial, and Institutional Developments, and Recreational Facilities
9. Utility Line Activities
10. Linear Transportation Projects
11. Mining Activities
12. Boat Ramps and Marine Railways
13. Land and Water-Based Renewable Energy Generation Facilities and Hydropower Projects
14. Reshaping Existing Drainage Ditches and Mosquito Management
15. Oil Spill and Hazardous Material Cleanup
16. Cleanup of Hazardous and Toxic Waste
17. Scientific Measurement Devices
18. Survey Activities
19. Agricultural Activities
20. Fish and Wildlife Harvesting, Enhancement, and Attraction Devices
21. Habitat Restoration, Establishment and Enhancement Activities
22. Previously Authorized Activities
23. Stream & Wetland Crossings
24. Aquaculture

Note: Multiple activities may be authorized in the same GP, e.g. a recreational pier (#3) with an associated mooring (#2) or a windpower facility (#13) with an associated transmission line (#9).

¹ Defined in Appendix F, Definitions and at 33 CFR 328.
Section II

III. PROCEDURES

1. State Approvals. Applicants are responsible for applying for and obtaining any of the required state or local approvals. Federal and state jurisdictions may differ in some instances. State permits may be required for specific projects regardless of the general permit category.

In order for authorizations under this GP to be valid, when any of the following state approvals or statutorily-required reviews is also required, the approvals must be obtained prior to the commencement of work in Corps jurisdiction.

- Maine Department of Environmental Protection (DEP): Natural Resources Protection Act (NRPA) permit, including permit-by-rule (PBR) and general permit authorizations; Site Location of Development Act permit; Maine Waterway Development and Conservation Act permit; and Maine Hazardous Waste, Septage, and Solid Waste Management Act license.
- Maine Department of Conservation, Agriculture & Forestry: Land Use Planning Commission (LUPC) permit.
- Maine Department of Marine Resources: Aquaculture Leases.
- Maine Department of Conservation, Bureau of Parks and Lands, Submerged Lands: Submerged Lands Lease.

NOTE: This GP may also be used to authorize projects that are not regulated by the State of Maine (e.g., certain seasonal floats or moorings).

2. How to Obtain/Apply for Authorization.

a. **Category 1 (Self-Verification):** Self-Verification Notification Form (SVNF) required. The SVNF is required for all SV eligible work in Maine unless otherwise stated in Appendix A. Activities that are eligible for SV are authorized under this GP and may commence without written verification from the Corps provided the prospective permittee has:

i. Confirmed that the activity will meet the terms and conditions of Category 1. Consultation with the Corps and/or other relevant federal and state agencies may be necessary to ensure compliance with the applicable general conditions (GCs) and related federal laws such as the National Historic Preservation Act (see GC 6), the Endangered Species Act (GC 8) and the Wild and Scenic Rivers Act (GC 9). Prospective permittees are encouraged to contact the Corps with SV eligibility questions. Activities not meeting the SV criteria must submit a PCN to the Corps.

ii. Submitted the SVNF (see GC 27 and Appendix B) to the Corps. **NOTE: A copy of a state permit application form may be an acceptable surrogate for the SVNF. Whichever form chosen needs to include a location map, plans, and an Official Species List for federally listed threatened or endangered species (Reference Appendix D).**

b. **Category 2 (Pre-Construction Notification (PCN)):** Application to and written verification from the Corps is required before work can proceed. For activities that do not qualify for SV or where otherwise required by the terms of the GP, the permittee must submit a PCN and obtain a written permit before starting work in Corps jurisdiction.

i. The Corps will coordinate review of all activities requiring PCN with federal and state agencies and federally recognized tribes, as appropriate. To be eligible and subsequently authorized, an activity must result in no more than minimal individual and cumulative effects on the aquatic environment as determined by the Corps in accordance with the criteria listed within this GP. This may require project modifications involving avoidance, minimization, or compensatory mitigation for unavoidable impacts to ensure that the net adverse effects of a project are no more than minimal.

ii. The Corps will attempt to issue a written eligibility determination within the state's review period. Regardless, work eligible for Category 2 may not proceed before Corps written approval is received.

c. All applicants for Category 2 projects must:

- i. Apply directly to the Corps using the state application form or the Corps application form (ENG Form 4345²), and apply directly to the state (DEP, LUPC, BPL or DMR) as applicable using the appropriate state form, if the work is regulated by the Corps and the state; or
 - ii. Apply directly to the Corps using the Corps application form (ENG Form 4345²) if the work is regulated by the Corps but not the state (DEP, LUPC, BPL or DMR).
 - iii. Provide application information (see “Information Typically Required” in Appendix C) to help ensure the application is complete and to speed project review.
 - iv. Obtain an Official Species List of federally threatened or endangered species in the project area (GC 8).
 - v. Submit a copy of their application materials to the Maine Historic Preservation Commission (MHPC) *and all five Indian tribes* listed at Appendix E, at the same time, or before, they apply to the Corps, to be reviewed for the presence of historic, archaeological or tribal resources in the permit area that the proposed work may affect. Submittals to the Corps shall include information to indicate that this has been done (a copy of the applicant’s cover letter to MHPC and tribes or a copy of the MHPC and tribal response letters is acceptable).
- d. Work that is not regulated by the State of Maine, but is subject to Corps jurisdiction, may still be eligible for authorization under this GP.

e. Emergency Situations: 33 CFR 325.2(e)4 states that an “emergency” is a situation which would result in an unacceptable hazard to life, a significant loss of property, or an immediate, unforeseen, and significant economic hardship if corrective action requiring a permit is not undertaken within a time period less than the normal time needed to process the application under standard procedures.” Emergency work is subject to the same terms and conditions of this GP as non-emergency work, and similarly, must qualify for authorization under the GP; otherwise an IP is required. The Corps will work with all applicable agencies to expedite verification according to established procedures in emergency situations.

3. Individual Permits. Projects that are not authorized by this GP require an Individual Permit (IP) (33 CFR 325.5) and proponents must submit an application directly to the Corps. This GP does not affect the Corps IP review process or activities exempt from Corps regulation. For general information and application form, see the Corps website or contact the Corps (see Appendix E). The Corps encourages applicants to apply concurrently for a Corps IP and applicable state permits.

The Corps retains discretionary authority on a case-by-case basis to elevate a GP eligible project to an IP based on concerns for the aquatic environment or for any other factor of the public interest [33 CFR 320.4(a)]. Whenever the Corps notifies an applicant that an IP is required, no work in Corps jurisdiction may be conducted until the Corps issues the required authorization in writing indicating that work may proceed.

4. Enforcement/Non-Compliance. Work performed without the required Corps of Engineers permits is subject to administrative, civil, and criminal penalties. The Corps will evaluate unauthorized activities for enforcement action under 33 CFR 326.

The Corps will consider unauthorized any activity requiring Corps authorization if that activity is under construction or completed and does not comply with all of the terms and conditions of a GP or an IP. The Corps may elect to suspend enforcement proceedings if the permittee modifies his project to comply with a GP.

After considering whether a violation was knowing or intentional, and other indications of the need for a penalty, the Corps can elect to terminate an enforcement proceeding with an after-the- fact authorization under a GP, if all terms and conditions of the GP have been satisfied, either before or after the activity has been accomplished.

² Located at www.nae.usace.army.mil/missions/regulatory under “Forms & Publications.”
Section III

IV. GENERAL CONDITIONS

To qualify for GP authorization, the prospective permittee must comply with the following general conditions, as applicable.

1. Other Permits
2. Federal Jurisdictional Boundaries
3. Minimal Direct, Secondary, and Cumulative Impacts
4. Mitigation (Avoidance, Minimization, and Compensatory Mitigation)
5. Single and Complete Projects
6. Historic Properties
7. Corps Projects and Property
8. Federal Threatened and Endangered Species
9. Wild and Scenic Rivers
10. Navigation
11. Federal Liability
12. Utility Line Installation and Removal
13. Heavy Equipment in Wetlands or Mudflats
14. Temporary Fill
15. Restoration of Special Aquatic Sites (including wetland areas).
16. Soil Erosion, Sediment and Turbidity Controls
17. Time of Year Windows/Restrictions.
18. Aquatic Life Movements & Management of Water Flows
19. Water Quality and Coastal Zone Management
20. Floodplains and Floodways
21. Storage of Seasonal Structures
22. Spawning, Breeding, and Migratory Areas
23. Vernal Pools
24. Invasive and Other Unacceptable Species
25. Programmatic Agreements
26. Permit On-Site
27. Self-Verification Notification Form (SVNF)
28. Inspections
29. Maintenance
30. Property Rights
31. Transfer of GP Verifications
32. Modification, Suspension, and Revocation
33. Special Conditions
34. False or Incomplete Information
35. Abandonment
36. Enforcement Cases
37. Duration of Authorization
38. Previously Authorized Activities
39. Discretionary Authority
40. St. John/St. Croix Rivers.
41. National Lands
42. Essential Fish Habitat (EFH)
43. Work Site Restoration
44. Bank Stabilization
45. Stream Work & Crossings and Wetland Crossings

1. Other Permits. Permittees must obtain other federal, state, or local authorizations required by law. Applicants are responsible for applying for and obtaining all required state or local approvals. This includes, but is not limited to, the project proponent obtaining a Flood Hazard Development Permit issued by the town, if necessary. Inquiries may be directed to the municipality or to the Maine Floodplain Management Coordinator at (207) 287-8063. See <http://www.maine.gov/dacf/flood/>

2. Federal Jurisdictional Boundaries

a. Applicability of this GP shall be evaluated with reference to federal jurisdictional boundaries. Applicants are responsible for ensuring that the boundaries used satisfy the federal criteria defined at 33 CFR 328 “Waters of the U.S.” and 33 CFR 329 “Navigable Waters of the U.S.”

NOTE: Waters of the U.S. include the subcategories “navigable waters of the U.S.” and “wetlands.”

b. For Category 1 projects, proponents are not required to delineate the waters of the U.S. that they plan to impact, but must approximate the square footage of impacts in order to determine the review category (1 or 2 or Individual Permit). For projects filling <15,000 square feet (SF) of waters of the U.S. that do not qualify for Category 1 (e.g., vernal pool, secondary or endangered species impacts, etc.) and therefore require an application to the Corps (PCN), and for those filling ≥15,000 SF, applicants shall delineate all waters of the U.S. that will be filled (direct impacts) in accordance with the Corps of Engineers Wetlands Delineation Manual and the most recent regional supplement (see Appendix C). In addition, applicants shall approximately identify all waters of the U.S. on the property and *known* waters adjacent to the property in order for the Corps to evaluate secondary impacts. The waters of the U.S. shall be clearly shown on the project plans submitted with the application. This includes all waters of the U.S. in areas under DEP or LUPC jurisdiction regardless of whether they’re shown on LUPC zoning maps.

c. On a case-by-case basis, the Corps may modify/refine the above delineation and identification requirements for waters of the U.S. See www.nae.usace.army.mil/missions/regulatory >> Jurisdictional Limits and Wetlands for more information on delineating jurisdictional areas.

3. Minimal Direct, Secondary, and Cumulative Effects³

a. Projects authorized by this GP shall have no more than minimal direct, secondary and cumulative adverse environmental impacts. Category 2 applicants should provide information on secondary and cumulative impacts as stated in Appendix C. Compensatory mitigation may be required to offset unavoidable impacts (see GC 4) and to ensure that they are no more than minimal. Compensatory mitigation requirements will be determined on a case-by-case basis.

b. Secondary impacts to waterway and/or wetland areas, (e.g., areas drained, flooded, cleared, excavated or fragmented) shall be added to the total fill area when determining whether the project qualifies for Category 1 or 2. Direct, secondary and cumulative impacts are defined at Appendix A, Endnote 2 and Appendix F.

c. Site clearing, grading and construction activities in the upland habitat surrounding vernal pools (“Vernal Pool Management Areas”) are secondary impacts. See GC 23 for avoidance and minimization requirements and recommendations.

d. Bank stabilization activities in tidal waters are provided at Appendix A, Page 30. Direct impacts in tidal waters from contiguous bank stabilization projects in excess of 200 linear feet (Applicant or Applicant + Abutters combined) must undergo Category 2 review.

4. Mitigation (Avoidance, Minimization, and Compensatory Mitigation)

a. Discharges of dredged or fill material into waters of the U.S., including wetlands, shall be avoided and minimized to the maximum extent practicable through consideration of alternatives. The Corps may require compensatory mitigation of unavoidable direct and secondary impacts associated with Category 2 projects on a case-by-case basis.

b. Applicants proposing work in jurisdictional waters should consider riparian/forested buffers for stormwater management and low impact development (LID) best management practices (BMPs) to reduce

³ Direct, secondary and cumulative effects are defined at Appendix F, Definitions and Acronyms.

impervious cover and manage stormwater to minimize secondary impacts to aquatic resources to the maximum extent practicable.⁴

c. Compensatory mitigation⁵ for effects to waters of the U.S., including direct, secondary and temporal⁶, may be required for permanent impacts that exceed the SV area limits, and may be required for temporary impacts that exceed the SV area limits, to offset unavoidable impacts which remain after all appropriate and practicable avoidance and minimization has been achieved and to ensure that the adverse effects to the aquatic environment are no more than minimal. Proactive restoration projects or temporary impact work with no lasting secondary effects may generally be excluded from this requirement. Refer to Appendix G.

5. Single and Complete Projects⁷

a. This GP shall not be used to piecemeal work and shall be applied to single and complete projects. When determining the review category in Appendix A (Category 1 or 2) for a single and complete project, proponents must include any permanent historic fill placed since October 1995 that is associated with that project and all currently proposed temporary and permanent impact areas.

b. A single and complete project must have independent utility⁷.

c. Unless the Corps determines the activity has independent utility:

i. This GP shall not be used for any activity that is part of an overall project for which an Individual Permit is required.

ii. All components of a single project and/or all planned phases of a multi-phased project (e.g., subdivisions should include all work such as roads, utilities, and lot development) shall be treated together as constituting one single and complete project.

d. For linear projects, such as power lines or pipelines with multiple crossings, the single and complete project is all crossings of a single water of the U.S. (i.e., single waterbody) at a specific location. For linear projects crossing a single waterbody several times at separate and distant locations, each crossing is considered a single and complete project. However, individual channels in a braided stream or river, or individual arms of a large, irregularly-shaped wetland or lake, etc., are not separate waterbodies and crossings of such features cannot be considered separately. If any crossing requires a Category 2 activity, then the entire linear project shall be reviewed as one project under Category 2.

6. Historic Properties

a. No undertaking shall cause effects (defined at 33 CFR 325 Appendix C and 36 CFR 800) on properties listed on, determined to be eligible for listing on, or potentially eligible for listing on the National Register of Historic Places⁸, including previously unknown historic properties within the permit area, unless the Corps or another Federal action agency has satisfied the consultation requirements of Section 106 of the National Historic Preservation Act (NHPA). The State Historic Preservation Officer (SHPO), Tribal Historic Preservation Officer (THPO) and the National Register of Historic Places can assist with locating information on: i) previously identified historic properties; and ii) areas with potential for the presence of historic resources, which may require identification and evaluation by qualified historic preservation and/or archaeological consultants in consultation with the Corps and the SHPO and/or THPO(s).

⁴ See: www.nae.usace.army.mil/missions/regulatory >> State General Permit >> Permit Resources >> Mitigation for this additional information: a) "Wetland BMP Manual - Techniques for Avoidance & Minimization," b) riparian/forested buffer BMPs, and c) LID BMPs. LID BMPs include, but are not limited to: replacing curbs and gutters with swales; using an open space design for subdivisions; using permeable, pervious or porous pavements; constructing bio-retention systems; and/or, adding a green roof or rain garden.

⁵ Compensatory mitigation projects provided to offset losses of aquatic resources must comply with the applicable provisions of 33 CFR 332. See also the New England District Compensatory Mitigation Guidance at www.nae.usace.army.mil/regulatory >> Mitigation.

⁶ Temporal loss: The time lag between the loss of aquatic resource functions caused by the permitted impacts and the replacement of aquatic resource functions at the compensatory mitigation site(s) (33 CFR 332.2).

⁷ Single and Complete Project and Independent Utility are defined in Appendix F - Definitions.

⁸ The majority of historic properties are not listed on the National Register of Historic Places and may require identification and evaluation by qualified historic preservation and/or archaeological consultants in consultation with the Corps and the SHPO and/or THPO(s).

b. For activities eligible for SV, proponents must ensure and document that the activity will not cause effects as stated in 6(a). Proponents must submit a PCN if the authorized activity may cause effects as stated in 6(a) as soon as possible to ensure that the Corps is aware of any potential effects of the permitted activity on any historic property to ensure all Section 106 requirements are met.

c. All PCNs shall: i) show notification to the SHPO and applicable THPO(s)⁹ for their identification of historic properties, ii) state which historic properties may be affected by the proposed work or include a vicinity map indicating the location of the historic properties or the potential for the presence of historic properties, and iii) include any available documentation from the SHPO or THPO(s) indicating that there are or are not historic properties affected. Starting consultation early in project planning can save proponents time and money.

d. If you discover any previously unknown historic, cultural or archeological remains and artifacts while accomplishing the activity authorized by this permit, you must immediately notify the district engineer of what you have found, and to the maximum extent practicable, avoid construction activities that may affect the remains and artifacts until the required coordination has been completed. The district engineer will initiate the Federal, Tribal and state coordination required to determine if the items or remains warrant a recovery effort or if the site is eligible for listing in the National Register of Historic Places.

7. Corps Projects and Property

a. In addition to any authorization under this GP, proponents must contact the Corps Real Estate Division at (978) 318-8585 for work occurring on or potentially affecting Corps properties and/or Corps-controlled easements to initiate reviews and determine what real estate instruments are necessary to perform work. Permittees may not commence work on Corps properties and/or Corps-controlled easements until they have received any required Corps real estate documents evidencing site-specific permission to work.

b. Any proposed temporary or permanent alteration, or modification or use, including occupation, of a federal project (including but not limited to a levee, dike, floodwall, channel, anchorage, breakwater, seawall, bulkhead, jetty, wharf, pier or other work built but not necessarily owned by the United States), which would obstruct or impair the usefulness of the federal project in any manner, and/or would involve changes to the authorized federal project's scope, purpose, and/or functioning that go beyond minor modifications required for normal operations and maintenance, is not eligible for SV and requires review and approval by the Corps pursuant to 33 USC 408. Where Section 408 is applicable, a decision on a Department of the Army general permit application will not be rendered prior to the decision on a Section 408 request.

c. Any structure or work within any Corps Federal Navigation Project (FNP) or its buffer zone¹⁰, shall be subject to removal at the owner's expense prior to any future Corps dredging or the performance of periodic hydrographic surveys. See GC 10 for more requirements related to FNPs.

8. Federal Threatened and Endangered Species

a. No activity is authorized which: i) is likely to directly or indirectly jeopardize the continued existence of a threatened or endangered species or a species proposed for such designation, as identified under the Federal Endangered Species Act (ESA), or which will directly or indirectly destroy or adversely modify the critical habitat of such species; ii) "may affect" a listed species or critical habitat, unless Section 7 consultation addressing the effects of the proposed activity has been completed; or iii) violates the ESA.

b. **All applicants must request an Official Species List from the US Fish & Wildlife Service and must include the list in the Corps permit application. To request an Official Species List, refer to the instructions in Appendix D.**

c. **For federally listed species in tidal waters, applicants should contact the National Marine Fisheries Service at: <http://www.greateratlantic.fisheries.noaa.gov/protected/section7/>**

⁹ Appendix E, 3(a)&(b). Historic Resources, provides contact information and each tribe's "area of concern."

¹⁰ See Appendix H for a list of FNPs. The buffer zone is equal to three times the authorized depth of the FNP.
Section IV

d. A PCN is required if a threatened or endangered species, a species proposed for listing as threatened or endangered, or designated or proposed critical habitat (all hereinafter referred to as “listed species or habitat”), as identified under the ESA, is present in the action area¹¹.

e. Federal agencies should follow their own procedures for complying with the requirements of the ESA but should coordinate that consultation with the Corps as well.

9. Wild and Scenic Rivers.¹² Any activity that occurs in the designated main stem of, within 0.25 mile up or downstream of the designated main stem of, or in tributaries within .25 miles of the designated main stem of a National Wild and Scenic River, or in “bordering and contiguous wetlands” (see Appendix A, Endnote 1) that are adjacent to the designated main stem of a National Wild and Scenic River, or that has the potential to alter flows within a river within the National Wild and Scenic River System, is not eligible for Category 1 regardless of size of the impacts. This condition applies to both designated Wild and Scenic Rivers and rivers officially designated by Congress as study rivers for possible inclusion while such rivers are in an official study status. National Wild and Scenic Rivers System segments for Maine as of October 2015 include: Allagash River beginning at Telos Dam continuing to Allagash checkpoint at Eliza Hole Rapids, approximately 3 miles upstream of the confluence with the St. John River (length = 92 miles); and 11.25 miles of the York River, in the State of Maine, from its headwaters at York Pond to the mouth of the river at York Harbor, plus its tributaries (currently under study).

10. Navigation

a. Any structure or work that extends closer to the horizontal limits of any Corps Federal Navigation Project (see Appendix H) than a distance of three times the project’s authorized depth shall be subject to removal at the owner’s expense prior to any future Corps dredging or the performance of periodic hydrographic surveys. This is applicable to Category 1 and 2. Reference Appendix A, Page 28 (Moorings) and Page 29 (Structures, Floats & Lifts).

b. There shall be no unreasonable interference with navigation by the existence or use of the activity authorized herein, and no attempt shall be made by the permittee to prevent the full and free use by the public of all navigable waters at or adjacent to the activity authorized herein.

c. The permittee understands and agrees that if future U.S. operations require the removal, relocation, or other alteration of the structure or work herein authorized, or if, in the opinion of the Secretary of the Army or his authorized representative, said structure or work shall cause unreasonable obstruction to the free navigation of the navigable waters, the permittee will be required, upon due notice from the Corps, to remove, relocate, or alter the structural work or obstructions caused thereby, without expense to the U.S. No claim shall be made against the U.S. on account of any such removal or alteration.

d. A PCN is required for all work in, over or under an FNP or its buffer zone unless otherwise indicated in Appendix A. (Reference Appendix A, Endnote 13, Page 36)

11. Federal Liability. In issuing this permit, the Federal Government does not assume any liability for the following: (a) damages to the permitted project or uses thereof as a result of other permitted or unpermitted activities or from natural causes; (b) damages to the permitted project or uses thereof as a result of current or future activities undertaken by or on behalf of the U.S. in the public interest; (c) damages to persons, property, or to other permitted or unpermitted activities or structures caused by the activity authorized by this permit; (d) design or construction deficiencies associated with the permitted work; (e) damage claims associated with any future modification, suspension, or revocation of this permit.

12. Utility Line Installation and Removal

a. Subsurface utility lines shall remain subsurface. If it is necessary to discharge dredged or filled material not previously authorized in order to keep such utility lines buried or restore them to their original subsurface condition, a PCN and written verification from the Corps may be required (e.g., in the case of side

¹¹ The “Endangered Species Consultation Handbook – Procedures for Conducting Consultation and Conference Activities Under Section 7 of the ESA,” defines action area as “all areas to be affected directly or indirectly by the Federal action and not merely the immediate area involved in the action. [50 CFR 402.02].”

¹² Additional information can be found at: <http://www.rivers.gov>.

casting into wetlands from utility trenches). Certain repair, replacement or maintenance activities may be eligible for Category 1 – refer to Appendix A.

b. Subsurface utility lines must be installed at a sufficient depth to avoid damage from anchors, dredging, etc., and to prevent exposure from erosion and stream adjustment. In accordance with Corps New England District Regulation NEDER 1110-1-9 (www.nae.usace.army.mil/missions/regulatory >> [Useful Links and Documents](#)), as an absolute minimum, the bottom cover associated with the initial installation of utility lines under navigable waters and navigation channels shall be 48 inches in soil or 24 inches in rock excavation in competent rock unless specified in a written determination. These minimum bottom cover requirements for pipelines and cables shall be measured from the maximum depth of dredging to the top of the utility. The maximum depth of dredging, in waterways having existing FNP, is generally considered to be the authorized project depth plus any allowance for advanced maintenance and the allowable overdepth for dredging tolerances. In waterways that do not have existing FNP, this depth should be taken as two feet below the existing bottom or maximum depth of proposed dredging, as applicable.

c. Aerial utility lines that cross navigable waters must meet minimum clearances. See 33CFR322.5(i).

d. For horizontal directional drilling work, returns of drilling fluids to the surface (i.e., frac-outs) are not authorized and require restoration to the maximum extent practicable in accordance with the terms and conditions of this GP. The permittee and its contractor shall have onsite and shall implement the procedures detailed in a frac-out contingency plan for monitoring drilling operations and for the immediate containment, control and recovery/removal of drilling fluids released into the environment should a discharge of material occur during drilling operations.

e. Within the context of any new installations, any abandoned or inactive utility lines should be removed and faulty lines (e.g., leaking hazardous substances, petroleum products, etc.) should be removed or repaired to the extent practicable. A PCN and written verification from the Corps is required if they are to remain in place, e.g., to protect sensitive areas or ensure safety.

f. No work shall drain a water of the U.S. by providing a conduit for water on or below the surface. Trench plugs installed along pipelines may be effective.

13. Heavy Equipment in Wetlands or Mudflats. Operating heavy equipment other than fixed equipment (drill rigs, fixed cranes, etc.) within wetlands shall be minimized, and such equipment shall not be stored, maintained or repaired in wetlands, to the maximum extent practicable. Where construction requires heavy equipment operation in wetlands, the equipment shall either have low ground pressure (typically <3 psi), or it shall be placed on swamp/construction/timber mats (herein referred to as “construction mats” and defined at Appendix A, Endnote 4) that are adequate to support the equipment in such a way as to minimize disturbance of wetland soil and vegetation. Construction mats are to be placed in the wetland from the upland or from equipment positioned on swamp mats if working within a wetland. Dragging construction mats into position is prohibited. Other support structures that are capable of safely supporting equipment may be used with written Corps authorization (Category 2 authorization or Individual Permit). Similarly, the permittee may request written authorization from the Corps to waive use of mats during frozen, dry or other conditions. An adequate supply of spill containment equipment shall be maintained on site. Construction mats should be managed in accordance with the Construction Mat BMPs at www.nae.usace.army.mil/missions/regulatory >> State General Permits >> Permit Resources.

14. Temporary Fill. Temporary fill that qualifies for Category 1 (e.g., <15,000 SF of combined temporary and permanent fill associated with the single and complete project) or is authorized in writing under Category 2, shall adhere to the following:

a. All temporary fill and disturbed soils shall be stabilized to prevent its eroding into waters of the U.S. where it is not authorized. Work shall include phased or staged development to ensure only areas under active development are exposed and to allow for stabilization practices as soon as practicable, typically within three calendar days after disturbance. Accelerated stabilization (the providing of temporary or permanent cover by the end of the work day to prevent erosion) shall be employed as necessary. Temporary fill must be placed in a manner that will prevent it from being eroded by expected high flows.

b. Unconfined temporary fill authorized for discharge into waters of the U.S. (e.g., temporary stream crossings) shall consist of material that minimizes impacts to water quality (e.g. washed stone, stone, etc.).

c. Appropriate measures must be taken to maintain normal downstream flows and minimize flooding to the maximum extent practicable when temporary structures, work, and discharges of dredged or fill material, including cofferdams, are necessary for construction activities, access fills, or dewatering of construction sites. Place materials in a location and manner that does not adversely impact surface or subsurface water flow into or out of the wetland. Temporary fill authorized for discharge into wetlands shall be placed on geotextile fabric or other appropriate material laid on the pre-construction wetland grade where practicable to minimize impacts and to facilitate restoration to the original grade. Construction mats are excluded from this requirement.

d. Temporary fill, construction mats and corduroy roads shall be entirely removed as soon as they are no longer needed to construct the authorized work. Temporary fill shall be placed in its original location or disposed of at an upland site and suitably contained to prevent its subsequent erosion into waters of the U.S. To qualify for Category 1, temporary fill placed during the: i.) growing season must be removed before the beginning of the next growing season; and ii.) non-growing season may remain throughout the following growing season, but must be removed before the beginning of the next growing season.

e. Temporary fill, construction mats and corduroy roads are considered temporary only if they are removed as soon as they are no longer needed to construct the authorized work.

f. Construction debris and/or deteriorated materials shall not be located in waters of the U.S.

15. Restoration of Special Aquatic Sites (Including Wetland Areas)

a. Temporary fills must be removed in their entirety and the affected areas restored to their pre-construction condition, function and elevation. Restoration shall typically commence no later than the completion of construction.

b. For excavated areas, “restored to pre-construction condition, function and elevation” means careful removal of existing soil and vegetation, separate topsoil and subsoil stockpiling, soil protection, and replacement back to the original location such that the original soil layering and vegetation schemes are approximately the same, unless otherwise authorized. Plan for natural settling that will occur (the initial post-restoration elevation of the backfilled areas should be above the desired final grade as topsoil may settle by 33% to 50%), minimize compaction, and ensure that topsoil is void of gravel and subsoil. A minimum of 4 inches of topsoil should be at the surface after the soil has settled. Wetland areas temporarily disturbed shall be stabilized (e.g., seeded or planted). Seed mixes and vegetation shall include only plant species native to New England and shall not include any species listed as “Invasive and Other Unacceptable Plant Species” in the “New England District Compensatory Mitigation Guidance” (see GC 24 and refer to Appendix G). This list may be updated periodically.

c. Limit compaction to the minimum needed to promote a successful seedbed; avoid a ‘fluffy’ seedbed, which is susceptible to erosion until the plants get established, and a compacted topsoil layer, which is counter-productive and will lead to greater erosion susceptibility down the road. Test soils for compaction. A soil probe, auger, or shovel should be able to retrieve samples of post-restoration profile. Equipment refusal shall be considered a failure of restoration, in which case the soil should be restored through deep-ripping and/or de-compaction, or other appropriate methods, and wetland hydrology must be maintained. See the BMPs at www.nae.usace.army.mil/missions/regulatory >> State General Permits >> Permit Resources >> Restoration.

d. In areas of authorized temporary disturbance, cut woody vegetation (trees, shrubs, etc.) shall be cut at or above ground level and not uprooted in order to prevent disruption to the wetland soil structure and to allow stump sprouts to revegetate the work area, unless otherwise authorized.

e. Trenches shall be constructed or backfilled so that the trench does not drain waters of the U.S. (e.g., materials or methods that create a French drain effect).

16. Soil Erosion, Sediment and Turbidity Controls

a. Adequate sedimentation and erosion control management measures, practices and devices, such as phased construction, installation of sediment control barriers (i.e. silt fence, vegetated filter strips, geotextile silt fences, erosion control mixes, hay bales or other devices) downhill of all exposed areas, retention of existing vegetated buffers, application of temporary mulching during construction, and permanent seeding and stabilization shall be installed and properly maintained to reduce erosion and retain sediment on-site during and after construction. They shall be capable of preventing erosion; of collecting sediment, suspended and floating materials; and of filtering fine sediment.

- b. Temporary sediment control barriers shall be removed upon completion of work, but not until all disturbed areas are permanently stabilized. The sediment collected by these sediment barriers shall be removed and placed at an upland location and stabilized to prevent its later erosion into a waterway or wetland.
- c. All exposed soil and other fills shall be permanently stabilized at the earliest practicable date .

17. Time of Year Work Windows/Restrictions. For activities where work is authorized in streams and tidal waters that causes turbidity or sediment re-suspension or other construction related disturbances, work must be conducted during the following TOY work windows (not during the TOY restrictions) unless otherwise authorized by the Corps under Category 2 review:

	<u>TOY Restriction</u> (no work)	<u>TOY Work Window</u> (work allowed)
Non-tidal waters	Oct. 01 through Jul. 14	Jul. 15 through Sep. 30
Tidal waters	Apr. 10 through Nov. 07	Nov. 08 through Apr. 09

Alternate windows authorized under Category 2 may include species specific windows recommended by the Maine Dept. of Marine Resources and/or Maine Dept. of Inland Fisheries & Wildlife.

18. Aquatic Life Movements & Management of Water Flows

- a. No activity may substantially disrupt the necessary life cycle movements of those species of aquatic life indigenous to the waterbody, including those species that normally migrate through the area, unless the activity’s primary purpose is to impound water. Unless otherwise stated, activities impounding water in a stream require a PCN to ensure impacts to aquatic life species are avoided and minimized. All permanent and temporary crossings of waterbodies (e.g., streams, wetlands) shall be:
 - i. Suitably culverted, bridged, or otherwise designed and constructed to maintain low flows to sustain the movement of those aquatic species; and
 - ii. Properly aligned and constructed to prevent bank erosion or streambed scour both adjacent to and inside the culvert. Permanent and temporary crossings of wetlands shall be suitably culverted, spanned or bridged in such a manner as to preserve hydraulic and ecological connectivity between the wetlands on either side of the road.
- b. To avoid adverse impacts on aquatic organisms, the low flow channel/thalweg shall remain unobstructed during periods of low flow, except when it is necessary to perform the authorized work.
- c. To the maximum extent practicable, the pre-construction course, condition, capacity, and location of open waters must be maintained for each activity, including stream channelization and storm water management activities. The activity must be constructed to withstand expected high flows. The activity must not restrict or impede the passage of normal or high flows, unless the primary purpose of the activity is to impound water or manage high flows. The activity may alter the preconstruction course, condition, capacity, and location of open waters if it benefits the aquatic environment (e.g., stream restoration or relocation activities).

19. Water Quality and Coastal Zone Management

- a. Applicants must satisfy any conditions imposed by the state and EPA, where applicable, in their CWA § 401 Water Quality Certifications (WQC) for this GP, or in any Individual § 401 WQC. See Appendix E for state-specific contact information and to determine if any action is required to obtain a 401 WQC. The Corps may require additional water quality management measures to ensure that the authorized activity does not cause or contribute to a violation of water quality standards. All projects authorized by this GP shall be designed, constructed and operated to minimize or eliminate the discharge of pollutants.
- b. Applicants must satisfy any additional conditions imposed by the state in their Coastal Zone Management (CZM) Act consistency concurrences for this GP, or in any Individual CZM consistency concurrences. The Corps may require additional measures to ensure that the authorized activity is consistent with state coastal zone management requirements.

20. Floodplains and Floodways

- a. Appropriate measures must be taken to minimize flooding to the maximum extent practicable.
- b. Activities within 100-Year Floodplains must comply with applicable Federal Emergency Management Agency (FEMA)-approved state and/or local floodplain management permitting requirements. Proponents may need to coordinate with FEMA and apply for a formal change to the flood insurance study products or forward a set of project plans and relevant technical documentation in a digital format to the Risk

Analysis Branch Chief, Mitigation Division, FEMA, Region 1, 99 High Street, Boston, Massachusetts 02110. Applicants should provide a copy of any documentation to the Corps along with the PCN.

c. Proponents may have to obtain a Flood Hazard Development Permit issued by the town. Inquiries may be directed to the municipality or to the Maine Floodplain Management Coordinator at (207) 287-8063. See <http://www.maine.gov/dacf/flood/>

21. Storage of Seasonal Structures. Seasonal or recreational structures such as pier sections, floats, aquaculture structures, etc. that are removed from the waterway for a portion of the year (often referred to as seasonal structures) shall be stored in an upland location landward of mean high water (MHW) or ordinary high water (OHW) and not in wetlands, tidal wetlands, their substrate or on mudflats. These seasonal structures may be stored on the fixed, pile-supported portion of the structure that is waterward of MHW or OHW. Seasonal storage of structures in navigable waters, e.g., in a protected cove on a mooring, requires Corps approval and local harbormaster approval.

22. Spawning, Breeding, and Migratory Areas

a. Jurisdictional activities and impacts such as excavations, discharges of dredged or fill material, and/or suspended sediment producing activities in jurisdictional waters that provide value as fish migratory areas, fish and shellfish spawning or nursery areas, or amphibian and migratory bird breeding areas, during spawning or breeding seasons shall be avoided and minimized to the maximum extent practicable.

b. Jurisdictional activities in waters of the United States that provide value as breeding areas for migratory birds must be avoided to the maximum extent practicable. The permittee is responsible for obtaining any “take” permits required under the USFWS’s regulations governing compliance with the Migratory Bird Treaty Act or the Bald and Golden Eagle Protection Act. The permittee should contact the appropriate local office of the USFWS to determine if such “take” permits are required for a particular activity (See Appendix E).

23. Vernal Pools

a. Only vernal pools that meet the current definition of waters of the U.S. are regulated by the Corps.

b. Direct and indirect adverse effects to all vernal pools (VPs), including their envelopes and critical terrestrial habitats (VP Management Areas¹³), shall be avoided and minimized to the maximum extent practicable. Site clearing, grading, and construction activities associated with a regulated activity in the VP Management Area may cause these adverse effects to the VP.

c. The State of Maine has specific protections for vernal pools.¹⁴

d. When any regulated activities occur within 750 feet of a vernal pool, the following management practices must be followed for all work within any VP Management Area (750’ of a VP’s edge) *in order to qualify for Category I*:

- i. No disturbance within the VP Depression or VP Envelope (area within 100 feet of the VP Depression’s edge)¹⁵;
- ii. Maintain a minimum of 75% of the Critical Terrestrial Habitat (area within 100-750 feet of the VP Depression’s edge) as unfragmented forest with at least a partly-closed canopy of overstory trees to provide shade, deep litter and woody debris;
- iii. Maintain or restore forest corridors connecting wetlands and significant vernal pools;
- iv. Minimize forest floor disturbance; and
- v. Maintain native understory vegetation and downed woody debris.

¹³ The Corps VP Management Area, which includes the VP and a 750’ radius from the VP’s edge, is defined at Appendix A, Endnote 5.

¹⁴ Appendix G, 10(a)-(d) provides links to the state’s Significant Wildlife Habitat regulations and references that provide impact minimization measures to reference when designing projects.

¹⁵ The no disturbance requirement in the VP envelope [see (b)(i)(1)], and (b)(i)(2), do not apply to temporary impacts associated with construction mats in previously disturbed areas of existing utility project (e.g., transmission lines, gas pipelines) or linear transportation project (e.g., roads, highways, railways, trails, airport runways and taxiways) right-of-ways provided there is a Vegetation Management Plan that avoids, minimizes and mitigates impacts to aquatic resources.

vi. Cape Cod style-curbings or no curbings options shall be used on new roads to facilitate amphibian passage. (Reference Appendix G)

e. A PCN is required for any regulated activity within 750' of a vernal pool when all work within the VP Management Area does not comply with the Category 1 requirements in (d) above. Information on directional buffers in accordance with the VP Directional Buffer Guidance document may be provided in order to demonstrate minimal impact and avoid compensation requirements (Reference Appendix G). Conservation of the un-impacted area within the VP Management Area will often be required.

f. GC 2 requires applicants to delineate or approximately identify on the project plans all waters of the U.S., which contain vernal pools.

g. GC 23(b-d) do not apply to projects that are within a municipality and meet the provisions of a Corps-approved VP Special Area Management Plan (VP SAMP) and are otherwise eligible for self-verification.

24. Invasive and Other Unacceptable Species¹⁶

a. The introduction or spread of invasive or other unacceptable plant or animal species on the project site or areas adjacent to the project site caused by the site work shall be avoided to the maximum extent practicable. For example, construction mats and equipment shall be thoroughly cleaned and free of vegetation and soil before and after use. The introduction or spread of invasive plant or animal species on the project site caused by the site work shall be controlled.

b. No cultivars, invasive or other unacceptable plant species may be used for any mitigation, bioengineering, vegetative bank stabilization or any other work authorized by this GP. However, non-native species and cultivars may be used when it is appropriate and specified in a written verification, such as using *Secale cereale* (Annual Rye) to quickly stabilize a site. All PCNs should explain the reason for using non-native species or cultivars.

25. Programmatic Consultations or Agreements. The Corps requirements to comply with Section 106 of the NHPA, Section 7 of the Endangered Species Act or Essential Fish Habitat conservation under the Magnuson-Stevens Act may be satisfied by a Programmatic Agreement with the Corps, New England District or another federal action agency. Any Corps, New England District Programmatic Agreements will be available on our website.

26. Permit On Site. The permittee shall ensure that a copy of this GP and any accompanying authorization letter with attached plans are at the site of the work authorized by this GP whenever work is being performed and that all construction personnel performing work which may affect waters of the U.S. are aware of its terms and conditions. The entire permit authorization shall be made a part of any and all contracts and subcontracts for work that affects areas of Corps jurisdiction at the site of the work authorized by this GP. This shall be achieved by including the entire permit authorization in the specifications for work. The term "entire permit authorization" means this entire GP and the authorization letter (including its drawings, plans, appendices and other attachments) and also includes permit modifications. If the authorization letter is issued after the construction specifications, but before receipt of bids or quotes, the entire permit authorization shall be included as an addendum to the specifications. If the authorization letter is issued after receipt of bids or quotes, the entire permit authorization shall be included in the contract or subcontract. Although the permittee may assign various aspects of the work to different contractors or subcontractors, all contractors and subcontractors shall be obligated by contract to comply with all environmental protection provisions contained within the entire GP authorization, and no contract or subcontract shall require or allow unauthorized work in areas of Corps jurisdiction.

¹⁶ For the purposes of this GP, plant species that are considered invasive and unacceptable are provided in Appendix G "Invasive and other Unacceptable Plant Species" of our document "Compensatory Mitigation Guidance" at www.nae.usace.army.mil/missions/regulatory >> Mitigation. Chapter 4(e) Planting is also particularly relevant. The June 2009 "Corps of Engineers Invasive Species Policy" provides policy, goals and objectives and is located at www.nae.usace.army.mil/missions/regulatory >> Invasive Species. Additional information can be found at: www.eddmaps.org/ipane.

27. Self-Verification Notification Form (SVNF). Permittees must complete and submit the SVNF provided at Appendix B to the Corps for work authorized by this GP unless otherwise noted in Appendix A. **NOTE: A copy of a state permit application form may be an acceptable surrogate for the SVNF provided either form used also include plans and an Official Species List of federally listed threatened or endangered species.**

28. Inspections. The permittee shall allow the Corps to inspect the authorized activity at any time deemed necessary to ensure that it is being or has been accomplished in accordance with the terms and conditions of this GP and any written verification. The Corps may also require post-construction engineering drawings for completed work, post-dredging survey drawings for any dredging work, or other post-construction reports. To facilitate these inspections, the permittee shall complete and return to the Corps the following forms:

- For Category 1/Self-Verification: The SVNF (see Appendix B).
- For Category 2/PCN: The a) Work-Start Notification Form and b) Compliance Certification Form, when either is provided with the authorization letter.

29. Maintenance

a. Any authorized structure or fill shall be properly maintained, including maintenance to ensure public safety and compliance with applicable general conditions and activity-specific conditions to a written verification.

b. The requirement in (a) above does not include maintenance of dredging projects. Each maintenance dredging event exceeding the self-verification limits requires a new PCN unless an unexpired, written PCN or other Corps authorization specifies that the permittee may “dredge and maintain” an area for a particular time period. Self-verification or PCN maintenance dredging includes only those areas and depths previously authorized and actually dredged. Maintenance dredging with ocean or open water disposal will always require a PCN and at least Category 2 review.

c. Some maintenance activities may not be subject to regulation under Section 404 in accordance with 33 CFR 323.4(a)(2). Refer to Appendix A, Endnote 7.

30. Property Rights. This GP does not convey any property rights, either in real estate or material, or any exclusive privileges, nor does it authorize any injury to property or invasion of rights or any infringement of federal, state, or local laws or regulations.

31. Transfer of GP Verifications. When the structures or work authorized by this GP are still in existence at the time the property is transferred, the terms and conditions of this GP, including any special conditions, will continue to be binding on the entity or individual who received the GP authorizations, as well as the new owner(s) of the property. If the permittee sells the property associated with a GP verification, the permittee may transfer the GP verification to the new owner by submitting a letter to the Corps (see Appendix E for address) to validate the transfer. A copy of the GP verification must be attached to the letter, and *the letter must contain the new owner’s contact information and the following statement and signature:*

“When the structures or work authorized by this GP are still in existence at the time the property is transferred, the terms and conditions of this GP, including any special conditions, will continue to be binding on the new owner(s) of the property. To validate the transfer of this GP and the associated liabilities associated with compliance with its terms and conditions, have the transferee sign and date below.”

(Transferee)

(Date)

32. Modification, Suspension, and Revocation. Any work authorized under this GP by self-verification or PCN may be either modified, suspended, or revoked, in whole or in part, pursuant to the policies and procedures of 33 CFR 325.7. Any such action shall not be the basis for any claim for damages against the U.S.

33. Special Conditions. The Corps may independently, or at the request of the federal resource agencies, impose other special conditions on a project authorized pursuant to this GP that are determined necessary to minimize adverse navigational and/or environmental effects or based on any other factor of the public interest. Failure to comply with all terms and conditions of the authorization, including special conditions, constitutes a permit violation and may subject the permittee to criminal, civil or administrative penalties and/or an ordered restoration.

34. False or Incomplete Information. If the Corps makes a determination regarding the eligibility of a project under this GP and subsequently discovers that it has relied on false, incomplete or inaccurate information provided by the permittee, the Corps may determine that the GP authorization is not valid; modify, suspend or revoke the authorization; and the U.S. Government may institute legal proceedings.

35. Abandonment. If the permittee decides to abandon the activity authorized under this GP, unless such abandonment is merely the transfer of property to a third party, he/she may be required to restore the area to the satisfaction of the Corps.

36. Enforcement cases. This GP does not apply to any existing or proposed activity in Corps jurisdiction associated with an ongoing Corps or EPA enforcement action, until such time as the enforcement action is resolved or the Corps or EPA, as appropriate, determines that the activity may proceed independently without compromising the enforcement action.

37. Duration of Authorization. This GP expires on October 12, 2020. Activities authorized under this GP that have commenced (i.e., are under construction) or are under contract to commence before this GP expires will have until October 12, 2021 to complete the activity under the terms and conditions of the current GP.

38. Previously Authorized Activities.

a. Projects that have received authorization (Category 1 or 2) from the Corps and that were completed under the previous PGPs, nationwide permits, regional general permits or letters of permission, shall remain authorized.

b. Activities authorized pursuant to 33 CFR Part 330.3 (“Activities occurring before certain dates”) are not affected by this GP.

c. Any work not commenced nor completed that was authorized in a written letter from the Corps under the GP in effect between October 12, 2010 and October 12, 2015 remains authorized subject to the terms and general conditions of this GP along with any special conditions in the authorizing written letter. Exception – if previously authorized work is not commenced and a new federally listed threatened or endangered species could be affected, the Corps must consult with the Service(s) prior to re-authorizing the work under this GP. Requests for re-authorization must include an updated Official Species list. To request an Official Species List, refer to the instructions in Appendix D.

39. Discretionary Authority. Notwithstanding compliance with the terms and conditions of this permit, the Corps retains discretionary authority to require Category 2 or Individual Permit review based on concerns for the aquatic environment or for any other factor of the public interest [33 CFR 320.4(a)]. This authority is invoked on a case-by-case basis whenever the Corps determines that the potential consequences of the proposal warrant a higher level of review based on the concerns stated above. This authority may be invoked for projects that may contribute to cumulative environmental impacts that are more than minimal or if there is a special resource or concern associated with a particular project that is not already covered by the remaining conditions of the GP and that warrants greater review. Whenever the Corps notifies an applicant that an Individual Permit may be required, the project is not authorized under this GP and no work may be conducted until an Individual Permit is obtained or until the Corps notifies the applicant that further review has demonstrated that the work may proceed under this GP.

40. St. John/St. Croix Rivers. Work within the Saint John and Saint Croix River basins that requires approval of the International Joint Commission is not eligible for Category 1 and a PCN to the Corps is required if any temporary or permanent use, obstruction or diversion of international boundary waters could affect the natural

flow or levels of waters on the Canadian side of the line; or if any construction or maintenance of remedial works, protective works, dams, or other obstructions in waters downstream from boundary waters could raise the natural level of water on the Canadian side of the boundary.

41. National Lands. Activities that impinge upon the value of any National Wildlife Refuge, National Forest, National Marine Sanctuary, National Park or any other area administered by the National Park Service, U.S. Fish and Wildlife Service (USFWS) or U.S. Forest Service are not eligible for Category 1 and require a PCN.

42. Essential Fish Habitat (EFH). Any work in the following rivers and streams, including all tributaries to the extent that they are currently or were historically accessible for salmon migration, shall not be authorized under Category 1 of the GP and must be screened for potential impacts to EFH (see Appendix G for more information).

Androscoggin River	Aroostook River	Boyden River	Dennys River
Ducktrap River	East Machias River	Hobart Stream	Kennebec River
Machias River	Narraguagus River	Orland River	Passagassawaukeag River
Patten Stream	Penobscot River	Pleasant River	Presumpscot River
Saco River	Sheepscot River	St. Croix River	Tunk Stream
			Union River

The above does not apply to the following activities which may qualify for Category 1 work:

- Exploratory drilling and borings for bridges.
- Moorings (see Appendix A, Page 28 for Category 1 thresholds and requirements)
- Structures, floats & lifts (see Appendix A, Page 29 for Category 1 thresholds and requirements)
- Other activities specified in a programmatic agreement with NMFS.

43. Work Site Restoration

a. Wetland areas where permanent disturbance is not authorized shall be restored to their original condition and elevation, which under no circumstances shall be higher than the pre-construction elevation. Original condition means careful protection and/or removal of existing soil and vegetation, and replacement back to the original location such that the original soil layering and vegetation schemes are approximately the same, unless otherwise authorized.

b. Upon completion of construction, all disturbed wetland areas (the disturbance of these areas must be authorized) shall be properly stabilized. Any seed mix shall contain only plant species native to New England and shall not contain any species listed in the “Invasive and Other Unacceptable Plant Species” Appendix in the “New England District Compensatory Mitigation Guidance” (see GC 24 and refer to Appendix G). This list may be updated periodically.

c. In areas of authorized temporary disturbance, if trees are cut they shall be cut at ground level and not uprooted in order to prevent disruption to the wetland soil structure and to allow stump sprouts to revegetate the work area, unless otherwise authorized.

44. Bank Stabilization

a. Projects involving construction or reconstruction/maintenance of bank stabilization structures within Corps jurisdiction shall be designed to minimize environmental effects, effects to neighboring properties, scour, etc. to the maximum extent practicable.

b. Project proponents must design and construct bank stabilization projects using this sequential minimization process: avoidance of aquatic resource impacts, diversion of overland flow, vegetative stabilization, stone-sloped surfaces, and walls/bulkheads. Vertical walls/bulkheads shall only be used in situations where reflected wave energy can be tolerated.

c. Inland Water bank stabilization activities necessary for erosion prevention must meet all of the following criteria: i) No material is placed in excess of the minimum needed for erosion protection; ii) The activity is no more than 500 feet in total length along the bank(s); iii) The activity will not exceed an average of one cubic yard per running foot placed along the bank below the plane of the ordinary high water mark; iv) Structures angled steeper than 1H:1V and any material other than angular or sub-angular stone or fiber roll revetments require at least a Category 2 review; v) The activity does not involve discharges of dredged or fill

material into special aquatic sites; vi) No material is of the type, or is placed in any location, or in any manner, to impair surface water flow into or out of any water of the U.S.; vii) No material is placed in a manner that will be eroded by normal or expected high flows (properly anchored trees and treetops may be used in low energy areas); and viii) The activity is not a stream channelization activity.

d. Bank stabilization activities in tidal waters are provided at Appendix A, Page 30 & 31. Direct impacts in tidal waters from contiguous bank stabilization projects in excess of 200 linear feet (Applicant or Applicant + Abutters combined) must undergo Category 2 review.

45. Stream Work and Crossings & Wetland Crossings

Notes:

a. For *Stream Work and Crossings* below, conditions (a) and (b) apply to Inland Waters and Wetlands (see Appendix A, Page 1 for definition) and Navigable Waters (see Appendix A, Page 27 for definition). Conditions (c)-(l) below only apply to Inland Waters and Wetlands that are streams. All new and replacement crossings in Navigable Waters require an application to the Corps and at least a Category 2 review.

b. In-stream work in a watershed occupied by listed Atlantic salmon, Atlantic sturgeon, or shortnose sturgeon [see GC 8(b)] and some stream work such as crossings on EFH waters (see GC 42) is not eligible for Category 1.

c. “High-Quality Stream Segments” are shown at www.maine.gov/dep/gis/datamaps and may be useful in evaluating impacts to fisheries. GIS shape files are under “Other Google Earth Interactive Maps” and PDFs by county are under “DEP GIS Maps.” See Appendix E for more state contact information.

Conditions for Stream Work and Crossings:

a. All permanent crossings of rivers, streams, brooks, etc. (hereon referred to as “streams”) shall be suitably culverted, bridged, or otherwise designed to i) withstand and to prevent the restriction of high flows to qualify for Category 1, and ii) not obstruct the movement of or not substantially disrupt the necessary life-cycle movements of those species of aquatic life indigenous to the waterbody, including those species that normally migrate through the area, beyond the actual duration of construction unless the activity’s primary purpose is to impound water to qualify for Category 1 or 2. (*NOTE: Areas of fill and/or cofferdams must be included in total waterway/wetlands impacts to determine applicability of this GP.*)

b. Any work that temporarily or permanently impacts upstream or downstream flood conditions, or permanently impacts wetlands in excess of Category 1 thresholds, must be reviewed at least under Category 2. See the documents referenced in Appendix G, 8(c) and (d) for guidance.

c. New Stream Crossings. For new stream crossings to qualify for Category 1:

i. Must ensure compliance with GC 45(a) and GC 45(b) above.

ii. Shall be designed and constructed in accordance with the Corps General Stream Crossing

Standards provided on Page 19 and the stream simulation document listed at Appendix G, 8(a).

d. Replacement Stream Crossings. For replacement stream crossings to qualify for Category 1:

i. Must ensure compliance with GC 45(a) and GC 45(b) above.

ii. Shall be designed and constructed in accordance with the Corps General Stream Crossing

Standards provided on Page 19 and the stream simulation document listed at Appendix G, 8(a).

e. Culvert Extensions. Culvert extensions on culverts that do not meet the Corps General Stream Crossing Standards do not qualify for Category 1 and require an application to the Corps and at least Category 2 review.

f. Temporary Stream Crossings.

Note: The General Stream Crossing Standards don’t apply to temporary stream crossings.

i. Temporary stream crossings or cofferdams shall be used for equipment access across streams [see Appendix G, 8(e)]. Note: Areas of fill and/or cofferdams must be included in total waterway/wetlands impacts to determine the review category in Appendix A.

ii. Temporary stream crossings shall be removed within 180 days to qualify for Category 1.

iii. Temporary stream crossings that are not spans¹⁷ (typically culverts) must be designed in accordance with 1-6 below to qualify for Category 1. Category 2 applications should include information demonstrating 2-6 below:

1. Installed and removed during the low flow period specified in GC 45(l) below.
2. Placed on geotextile fabric or other material where practicable to ensure restoration to the original grade. Soil may not be used to construct or stabilize these structures and rock must be large enough to allow for easy removal without disrupting the streambed.
3. Designed and maintained to withstand and pass high flows. Water height should be no higher than the top of the culvert's inlet. A minimum culvert diameter of two feet is required to pass debris. Culverts must be aligned to prevent bank erosion or streambed scour.
4. Equipped with energy dissipating devices installed downstream if necessary to prevent scour.
5. Designed and maintained to prevent soil from entering the waterbody.
6. Removed upon the completion of work. Impacts to the streambed or banks requires restoration to their original condition using stream simulation methods¹⁸.

g. Slip Lining. Work using slip lining (retrofitting an existing culvert by inserting a smaller diameter pipe), invert lining, or resulting in decreased diameter, does not qualify for Category 1, either as new work or maintenance activities.

h. Work in Flowing Waters. To qualify for Category 1, no unconfined fill [see GC 14(b)] or excavation in flowing waters is allowed. To accomplish this:

i. Bank stabilization work below ordinary high water (OHW) shall utilize erosion controls such as inflatable cofferdams, jersey barrier, silt screen, turbidity curtain, etc. where practicable to prevent sediment input to the stream and to minimize turbidity and sedimentation impacts for sensitive life stages. Bank stabilization above OHW must utilize erosion controls.

ii. Management techniques such as temporary flume pipes, culverts, cofferdams, etc. must be used to maintain normal flows within the stream boundary's confines, or water diversions may be used immediately up and downstream of the work footprint (see Appendix A, Endnote 6) or work must be performed in the dry under no flow conditions, or under very low flow conditions following the practices in GC 45(a).

i. Minimization. In order to make the Category 2 review process more efficient and result in a faster decision, new and replacement stream crossings should be designed using the least intrusive and environmentally damaging method following this sequential minimization process: 1) spans with no stream impacts, 2) spans with stream impacts, and 3) embedded culverts with stream simulation or low-slope design.

j. Maintenance Requirements. The permittee shall maintain the work authorized herein in good condition and in conformance with the terms and general conditions of this permit to facilitate aquatic life passage as stated in GC 45(a). Culverts that develop "hanging" inlets or outlets, result in bed washout, or a stream that doesn't match the characteristics of the substrate in the natural stream channel such as mobility, slope, stability confinement will require maintenance or repair to comply with this GC. This does not apply to GC 45(f) above.

k. Maintenance and Replacement Information. An existing stream crossing must be authorized and in compliance with all conditions of its authorization(s) to qualify for maintenance not subject to regulation. See Appendix A, Endnote 7. A non-serviceable crossing is not eligible for maintenance and is therefore considered as a replacement crossing [see GC 45(d)].

l. Work Window. For projects that otherwise meet the terms of Category 1, in-stream construction work shall be conducted during the low flow period July 15 – September 30 in any year. Projects that are not to be conducted during that time period are ineligible for Category 1 and shall be screened pursuant to Category 2, regardless of the waterway and wetland fill and/or impact area.

Corps General Stream Crossing Standards (required for Category 1; recommended for Category 2):

- a. Culverts must be embedded:

¹⁷ For the purposes of this GP, spans are bridges, three-sided box culverts, open-bottom culverts or arches that span the stream with footings landward of bankfull width.

¹⁸ Design and construction shall be in accordance with the stream simulation document listed at Appendix G, 8(a).

- ≥ 2 feet for box culverts and other culverts with smooth internal walls,
- ≥ 1 foot for corrugated pipe arches
- ≥ 1 foot and at least 25 percent for corrugated round pipe culverts

b. **For new crossings**, spans¹⁷ are required to avoid or cause minimal disruption to the streambed and to meet the requirements of General Condition 45(a) and 45(b). Footings and abutments must be landward of 1.2 times bankfull width. To the greatest extent practicable, work in the stream shall be minimized, and design and construction shall allow the streambed's natural structure and integrity to remain intact. Any fill or excavation of the streambed below bankfull width other than footings, support pilings, or work specified in 45(h)ii requires Category 2 review and, unless demonstrated otherwise, stream simulation¹⁸ to establish substrate and banks in the span structure and work area as specified in (d) and (e) below.

c. **For replacement crossings**, spans¹⁷ are required to meet the requirements of General Condition 45(a) and 45(b). Footings and abutments shall be landward of 1.2 times bankfull width. Unless demonstrated otherwise, stream simulation¹⁸ is required to establish substrate and banks in the span structure and work area as specified in (d) and (e) below.

d. Crossings must have a natural bottom substrate within the structure matching the characteristics of the substrate in the natural stream channel and the banks (mobility, slope, stability, confinement, grain and rock size) at the time of construction and over time as the structure has had the opportunity to pass significant flood events. To allow terrestrial passage for wildlife and prevent undermining the footings, crossings shall have a bank on both sides of the stream matching the horizontal profile of the existing stream and banks¹⁸. Note: Installation of substrate material within smaller culverts may not be safe or practicable. In these cases, it may be necessary to allow for natural deposition and bed development unless alternative methods are identified.

e. Crossings must be designed and constructed¹⁸ with appropriate bed forms and streambed characteristics so that water depths and velocities are comparable to those found in the natural channel at a variety of flows. In order to provide appropriate water depths and velocities at a variety of flows and especially low flows, it is usually necessary to reconstruct the streambed or preserve the natural channel within the structure. Otherwise, the width of the structure needed to accommodate higher flows will create conditions that are too shallow at low flows. The grain and rock size, and arrangement of streambed materials within the structure should be in accordance with (d) above. Flows could go subsurface within the structure if only large material is used without smaller material filling the voids.

Conditions for Wetland Crossings:

a. All temporary and permanent crossings of wetlands shall be suitably culverted, bridged, or otherwise designed to: i) Withstand and prevent the restriction of high flows, ii) Not obstruct the movement of or not substantially disrupt the necessary life-cycle movements of those species of aquatic life indigenous to the wetland, including those species that normally migrate through the area, beyond the actual duration of construction unless the activity's primary purpose is to impound water. See Appendix E for the Maine DEP's crossing standards.

b. To qualify for Category 1, new and replacement wetland crossings that are permanent shall be culverted, spanned or bridged in such a manner as to preserve hydraulic and ecological connectivity, at its present level, between the wetlands on either side of the road. To meet this requirement, we recommend that culverts, spans or bridges be placed at least every 50 feet with an opening at least 2 feet high and 3 feet wide at ground level where practicable. Closed bottom culverts shall be embedded at least 6 inches with a natural bottom.

c. In the case of non-compliance, the permittee shall take necessary measures to correct wetland damage due to lack of hydraulic and ecological connectivity.

d. Any work that results in flooding, results in impacts to wetlands on either side of the wetland crossing in excess of Category 1 thresholds, or impacts wetland drainage from the upgradient side of the wetland crossing does not qualify for Category 1.



Robert J. Desista
Deputy Chief, Regulatory Division
For DISTRICT ENGINEER

DATE 10/13/15

APPENDIX A: DEFINITION OF CATEGORIES

<p>A. INLAND WATERS AND WETLANDS</p>	<p>Inland Waters and Wetlands: Waters that are regulated under Section 404 of the Clean Water Act, including rivers, streams, lakes, ponds and wetlands, and <i>excluding Section 10 Navigable Waters of the U.S. (tidal and freshwater)</i>. The jurisdictional limits are the ordinary high water (OHW) mark in the absence of adjacent wetlands, beyond the OHW mark to the limit of adjacent wetlands when adjacent wetlands are present, and the wetland limit when only wetlands are present. For the purposes of this GP and designated activities, fill placed in the area between the mean high water (MHW) and the high tide line (HTL), and in the bordering and contiguous wetlands¹ to tidal waters are reviewed in the Navigable Waters section. (See B. Navigable Waters on page 27 below.)</p> <p>Projects not meeting Category 1 require an application for review as a Category 2 or Individual Permit project.</p> <p>All Category 1 and 2 projects must comply with all of this GP's applicable terms (Pages 1 – 4) and General Conditions (Pages 5–20).</p>	
<p>ACTIVITY</p>	<p>CATEGORY 1 Self-Verification Eligible (SVNF Required)</p>	
<p>1. Repair, Replacement, and Expansion, and Maintenance of Authorized Structures and Fills</p>	<p>Repair or maintenance of existing, currently serviceable, authorized fills with no expansion or change in use:</p> <ul style="list-style-type: none"> • Conditions of the original authorization apply. • Minor deviations in fill design allowed.⁷ • The repair, rehabilitation, or replacement of those structures or fills destroyed or damaged by storms, floods, fire or other discrete events is authorized, provided the repair, rehabilitation, or replacement is commenced, or is under contract to commence, within two years of the date of their destruction or damage. • No effect on federally listed endangered or threatened species or critical habitat. 	<p>CATEGORY 2 (PCN Required)</p> <p>Replacement of non-serviceable fills, or repair/maintenance of serviceable fill, with expansion <3 acres, or with a change in use.</p>
<p>2. Moorings</p>	<p>NA – moorings in non-navigable inland waters are not subject to Corps jurisdiction.</p> <p>Note: Moorings placed in freshwater navigable waters are reviewed in the Navigable Waters section. (See B. Navigable Waters on Page 28 below.)</p>	<p>NA</p>
<p>3. Structures, Floats & Lifts</p>	<p>For solid fill or crib supported structures on inland waters, <15,000 square feet (SF) of waterway and/or wetland fill, associated secondary impacts², and temporary fills.</p> <ul style="list-style-type: none"> • No effect on federally listed endangered or threatened species or critical habitat. • Note: Temporary or permanent structures placed in freshwater navigable waters are reviewed in the Navigable Waters section. (See B. Navigable Waters on page 29 below.) 	<p>1. Work not eligible for Category 1</p> <p>2. ≥15,000 SF to <3 acres of inland waterway and/or wetland fill and associated secondary impacts (e.g., areas drained, flooded, fragmented, or excavated).</p>
<p>4. Aids to Navigation and Temporary Recreational Structures</p>	<p>NA - this activity in non-navigable inland waters is not subject to Corps jurisdiction.</p> <p>Note: Aids to Navigation and other structures placed in freshwater navigable waters are reviewed in the Navigable Waters section. (See B. Navigable Waters on page 30 below.)</p>	<p>NA</p>

<p>5. Dredging, Disposal of Dredged Material, Beach Nourishment, and Rock Removal and Relocation</p>	<p>1. For regulated discharges associated with excavation, and disposal <15,000 SF inland waterway and/or wetland impacts.</p> <p>2. The activity does not occur in navigable waters of the U.S.</p> <p>3. Stream channelization, relocation or loss of streambed including impoundments or discharge of tailings into streams does not occur.</p> <p>4. No effect on federally listed endangered or threatened species or critical habitat.</p>	<p>1. Work not eligible for Category 1</p> <p>2. ≥15,000 SF to <3 acres of inland waters.</p>
<p>6. Discharges of Dredged or Fill Material Incidental to the Construction of Bridges</p>	<p>NA - For discharges incidental to the construction of bridges in inland waters of the U.S. refer to Activity 23 (Stream and Wetland Crossings) and GC 45.</p> <p>Note: Discharges of Dredged or Fill Material Incidental to the Construction of Bridges in freshwater navigable waters are reviewed in the Navigable Waters section. (See B. Navigable Waters on page 30 below.)</p>	<p>NA</p>
<p>7. Bank and Shoreline Stabilization</p>	<p>Inland bank stabilization <500 FT long and ≤1 CY of fill per linear foot below OHW, provided:</p> <ul style="list-style-type: none"> • ≤1 cubic yard of fill per linear foot placed along the bank waterward of ordinary high water. • Work complies with the GCs (GC 44 in particular), including: <ul style="list-style-type: none"> o No structures angled steeper than 1H:1V allowed. Only rough-faced stone or fiber roll revetments allowed. o No in-stream work involving fill or excavation in flowing waters (see GC 45(h)). • In-water work limited to Jul 15 – Sep 30. • No work in vernal pools⁵ or SAS³. • No effect on federally listed endangered or threatened species or critical habitat. 	<p>Work not eligible for Category 1</p>
<p>8. Residential, Commercial, Industrial, and Institutional Developments, and Recreational Facilities</p>	<p>1. <15,000 SF of inland waterway and/or wetland fill and associated secondary impacts² (e.g., areas drained, flooded, fragmented, mechanically cleared or excavated). Fill area includes all temporary and permanent fill, and regulated discharges associated with excavation. Construction mats are considered as fill. [See GC 14]</p> <p><u>Provided:</u></p> <ul style="list-style-type: none"> • Historic fill + proposed impact area <15,000 SF complies with GC 5, Single and Complete Projects. • No work in special aquatic sites (SAS)⁴ other than wetlands. • No effect on federally listed endangered or threatened species or critical habitat. <p>2. For work in Vernal Pool (VP) Management Areas (includes VPs)⁵:</p>	<p>1. Work not eligible for Category 1.</p> <p>2. ≥15,000 SF to <3 acres of inland waterway and/or wetland fill and associated secondary impacts (e.g., areas drained, flooded, fragmented, or excavated). Fill area includes all temporary and permanent fill (including mats), and regulated discharges associated with excavation.</p> <p>3. <i>Mechanical clearing without grubbing or other soil disturbance > 3 acres as a secondary impact may still be eligible for Category 2 at the discretion of the Corps.</i></p> <p>See GC 2 and Appendix C for wetland delineation</p>

	<ul style="list-style-type: none"> • See GC 23 and Appendix C for VP delineation requirements. • See GC 23 to determine if work qualifies for Category 1 or 2. • See Appendix G for VP documents providing mitigation guidance. 	requirements.
<p>9. Utility Line Activities</p>	<ol style="list-style-type: none"> 1. <15,000 SF of inland waterway and/or wetland fill, associated secondary impacts², and temporary fills. 2. The activity does not occur in, over, or under navigable waters of the U.S. 3. Intake structures that are dry hydrants used exclusively for firefighting activities with no stream impoundments. 4. There is no permanent change in pre-construction contours in waters of the U.S. 5. Material resulting from trench excavation is temporarily side cast into waters of the U.S. for ≤3 months and is placed in such a manner that it is not dispersed by currents or other forces. 6. The utility line is placed within and does not run a) parallel to, or b) along a streambed. 7. Stream channelization, relocation or loss of streambed including impoundments does not occur. 8. No effect on federally listed endangered or threatened species or critical habitat. 9. There is no discharge in SAS other than non-tidal wetlands. 10. Construction mats⁴ of any area necessary to conduct activities that were previously authorized, authorized under Category 1, or not subject to regulation (see Endnote 7). Authorized construction mats must be in place for <3 months, removed immediately upon work completion, and the wetlands must be restored (see GC 43). 11. Stream crossings must comply with GC 17. 	<ol style="list-style-type: none"> 1. Work not eligible for Category 1 2. ≥15,000 SF to <3 acres of inland waterway and/or wetland fill and associated secondary impacts (e.g., areas drained, flooded, fragmented, or excavated). Fill area includes all temporary and permanent fill (including mats), and regulated discharges associated with excavation. 3. <i>Mechanical clearing without grubbing or other soil disturbance >3 acres as a secondary impact may still be eligible for Category 2 at the discretion of the Corps.</i>
<p>10. Linear Transportation Projects (not including stream crossings)</p> <p>For stream crossings, refer to Activity 23</p>	<ol style="list-style-type: none"> 1. <15,000 SF of inland waterway and/or wetland fill associated secondary impacts (e.g., areas drained, flooded, fragmented, mechanically cleared or excavated). Fill area includes all temporary and permanent fill, and regulated discharges associated with excavation. Construction mats are considered fill. (See GC 14.) Provided: <ul style="list-style-type: none"> • Historic fill + proposed impact area <15,000 SF and complies with GC 5 single and complete projects. • No work in special aquatic sites (SAS) other than wetlands. 2. Construction mats⁴ of any area necessary to conduct activities that were previously authorized, authorized under Category 1, or not subject to regulation (see Endnote 7). Authorized construction mats must be in place for <3 months, removed immediately upon work completion, and the wetlands must be restored (see GC 43). 3. No effect on federally listed endangered or threatened species or critical habitat. 	<ol style="list-style-type: none"> 1. ≥15,000 SF to <3 acres of inland waterway and/or wetland fill and associated secondary impacts (e.g., areas drained, flooded, fragmented, or excavated). Fill area includes all temporary and permanent fill (including mats), and regulated discharges associated with excavation. 2. <i>Mechanical clearing without grubbing or other soil disturbance >3 acres as a secondary impact may still be eligible for Category 2 at the discretion of the Corps.</i>

<p>11. Mining Activities</p>	<p>1. <15,000 SF of inland waterway and/or wetland fill, associated secondary impacts, and temporary impacts. 2. The activity does not occur in navigable waters of the U.S. 3. Stream channelization, relocation or loss of streambed including impoundments or discharge of tailings into streams does not occur. 4. No effect on federally listed endangered or threatened species or critical habitat.</p>	<p>1. Work not eligible for Category 1. 2. ≥15,000 SF to <3 acres of inland waterway and/or wetland fill and associated secondary impacts (e.g., areas drained, flooded, fragmented, or excavated). Fill area includes all temporary and permanent fill (including mats), and regulated discharges associated with excavation.</p>
<p>12. Boat Ramps</p>	<p>1. <15,000 SF of inland waterway and/or wetland fill, associated secondary impacts, and temporary impacts. 2. No effect on federally listed endangered or threatened species or critical habitat.</p>	<p>1. Work not eligible for Category 1 2. >15,000 SF and < 3 acres of impact.</p>
<p>13. Land and Water-Based Renewable Energy Generation Facilities and Hydropower Projects</p>	<p><i>For land-based facilities:</i> 1. <15,000 SF of inland waterway and/or wetland fill, associated secondary impacts, and temporary impacts. 2. Stream channelization, relocation or loss of streambed including impoundments does not occur. 3. No effect on federally listed endangered or threatened species or critical habitat. <i>For water-based facilities and hydropower projects:</i> No new facilities are eligible. Not Applicable</p>	<p><i>For land-based activities:</i> 1. Work not eligible for Category 1. 2. >15,000 SF and < 3 acres impact. 3. <i>Mechanical clearing without grubbing or other soil disturbance >3 acres as a secondary impact may still be eligible for Category 2 at the discretion of the Corps.</i> <i>For water-based facilities and hydropower projects:</i> > 3 acres of impact will require an IP.</p>
<p>14. Reshaping Existing Drainage Ditches & Mosquito Management</p>	<p>Not Applicable</p>	<p>Not Applicable</p>
<p>15. Oil Spill and Hazardous Material Cleanup</p>	<p>Jurisdictional activities required for the containment and cleanup of oil and hazardous substances that are subject to the National Oil and Hazardous Substances Pollution Contingency Plan (40 CFR 300) provided that the work is done in accordance with the Spill Control and Countermeasure Plan required by 40 CFR 112.3 or any existing state contingency plan and provided that the Regional Response Team (if one exists in the area) concurs with the proposed containment and cleanup action. SAS³ must typically be restored in place at the same elevation. <i>Note: SVN/F or a surrogate state reporting form may be submitted after the fact.</i></p>	<p>Work not eligible for Category 1</p>

<p>16. Cleanup of Hazardous and toxic waste</p>	<p>Specific jurisdictional activities to effect the containment, stabilization, or removal of hazardous or toxic waste materials, including court ordered remedial action plans or related settlements, which are performed, ordered or sponsored by a government agency with established legal or regulatory authority. SAS should be restored in place at the same elevation.</p> <ul style="list-style-type: none"> • <15,000 SF of inland waterway and/or wetland fill, associated secondary impacts, and temporary impacts. • No stream channelization, relocation or loss of streambed occurs. • The project does not involve establishing new disposal sites or expanding existing sites used for the disposal of hazardous or toxic waste. • No effect on federally listed endangered or threatened species or critical habitat. 	<p>Work not eligible for Category 1</p>
<p>17. Scientific Measurements Devices</p>	<ol style="list-style-type: none"> 1. Scientific measurement devices whose purpose is to measure and record scientific data, such as staff gages, water recording devices, water quality testing and improvement devices, and similar structures. This excludes any biological sampling devices. Structures may not restrict or concentrate movement of aquatic organisms. 2. No effect on federally listed endangered or threatened species or critical habitat. 	<p>Work not eligible for Category 1</p>
<p>18. Survey Activities</p>	<ol style="list-style-type: none"> 1. Jurisdictional survey activities, such as core sampling, seismic exploratory operations, plugging of seismic shot holes and other exploratory-type bore holes, exploratory trenching, soil surveys, sampling, and historic resources surveys (but not recovery). Exploratory trenches must be restored in accordance with GC 43. The construction of temporary pads is authorized provided the discharge doesn't exceed 25 CY. This doesn't authorize permanent structures or the drilling and the discharge of excavated material from test wells for oil and gas exploration (the plugging of such wells is authorized). 2. No effect on federally listed endangered or threatened species or critical habitat. 	<p>Work not eligible for Category 1</p>
<p>19. Agricultural Activities</p>	<ol style="list-style-type: none"> 1. For those activities subject to Corps jurisdiction¹⁶, <15,000 SF of inland waterway and/or wetland fill, associated secondary impacts, and temporary impacts. 2. No stream channelization, relocation, loss of streambed, or farm ponds in streams. 3. No effect on federally listed endangered or threatened species or critical habitat. 	<ol style="list-style-type: none"> 1. ≥15,000 SF to <3 acres of inland waterway and/or wetland fill and associated secondary impacts (e.g., areas drained, flooded, fragmented, or excavated). Fill area includes all temporary and permanent fill (including mats), and regulated discharges associated with excavation. 2. > 3 acres of impact will require an IP.

<p>20. Fish and Wildlife Harvesting, Enhancement and Attraction Devices and Activities</p>	<p>NA - this activity in non-navigable inland waters, if not involving a discharge of dredged or fill material, is not subject to Corps jurisdiction. Note: Related structures placed in freshwater navigable waters (e.g. the upper Penobscot or Kennebec Rivers) are reviewed in the Navigable Waters section. (See B. Navigable Waters on Page 33 below.)</p>	<p>Not Applicable</p>
<p>21. Habitat Restoration, Establishment and Enhancement Activities</p>	<p>1. <15,000 SF of inland waterway and/or wetland fill, associated secondary impacts, and temporary impacts. 2. The activity is supported in writing by a local, state, or non-Corps Federal environmental agency. Water impoundments require PCN. 3. No conversion of i) a stream to wetland or vice versa, wetland to a pond or uplands, and ii) one wetland type to another. 4. No dam removal. 5. No effect on federally listed endangered or threatened species or critical habitat.</p>	<p>1. Work not eligible for Category 1 2. Aquatic habitat restoration, establishment, and enhancement of wetlands and riparian areas and the restoration and enhancement of streams and other open waters with impacts of any area \geq 15,000 SF, provided those activities result in net increase in overall aquatic resource functions and services.⁸</p>
<p>22. Previously Authorized Activities</p>	<p>Any work not commenced nor completed that was authorized in a written letter from the Corps under the GP in effect between October 12, 2010 and October 12, 2015. The terms and general conditions of this GP apply along with any special conditions in the written authorization.</p>	
<p>23. Stream & Wetland Crossings</p>	<p>1. River, stream and brook work and crossings: <ul style="list-style-type: none"> • Must comply with GC 45 in particular, including: <ul style="list-style-type: none"> o No slip lining [see GC 45 (g)]. o No in-stream work involving fill or excavation in flowing waters [see GC 45(h)]. o In-stream work limited to Jul 15 – Sep 30 [see GC 45 (l)]. • No work in riffles and pools³. • No stream relocations. • No dams or dikes⁶. • No effect on federally listed endangered or threatened species or critical habitat. • <15,000 SF of inland waterway and/or wetland fill, associated secondary impacts, and temporary impacts. 2. Wetland crossings must comply with the particularly relevant GC 45.</p>	<p>Work not eligible for Category 1</p>
<p>24. Aquaculture (freshwater)</p>	<p>For land based installations, <15,000 SF of inland waterway and/or wetland fill, associated secondary impacts, and temporary impacts. <ul style="list-style-type: none"> • In-stream/in-water work limited to Jul 15 – Sep 30. • No effect on federally listed endangered or threatened species or critical habitat. Note: Related structures placed in freshwater navigable waters are reviewed in the Navigable Waters section. (See B. Navigable Waters, below.)</p>	<p>Work not eligible for Category 1</p>

<p>B. NAVIGABLE WATERS</p>	<p>Navigable Waters of the United States: Waters that are subject to the ebb and flow of the tide and/or the tidal and non-tidal portions of the Federally designated navigable waters (the Penobscot River, Kennebec River, and Lake Umbagog) (Section 10 Rivers and Harbors Act of 1899). The jurisdictional limits are the mean high water (MHW) line in tidal waters and the ordinary high water (OHW) mark in non-tidal portions of the federally designated navigable rivers. For the purposes of this GP, fill placed in the area between the mean high water (MHW) and the high tide line (HTL), and in the bordering and contiguous wetlands¹ to tidal waters are also reviewed in this Navigable Waters section.</p> <p>Projects not meeting Category 1 require an application for review as a Category 2 or Individual Permit project.</p> <p>All Category 1 and 2 projects must comply with all of this GP's applicable terms (Pages 1 - 4) and General Conditions (Pages 5 - 20).</p>	
<p>ACTIVITY</p>	<p>CATEGORY 1 Self-Verification Eligible (SVNF Required)</p>	<p>CATEGORY 2 (PCN Required)</p>
<p>1. Repair, Replacement, and Expansion of Maintenance of Authorized (or Grandfathered) Structures and Fills</p>	<p>1. Repair, replacement in-kind, or maintenance⁷ of existing, currently serviceable⁷, authorized structures or fills:</p> <ul style="list-style-type: none"> • All work is to be conducted in-the-dry, during low water. • Conditions of the original authorization apply. • No substantial expansion or change in use. • No new fill in SAS³. • Must be rebuilt in same footprint, however minor deviations in structure design allowed⁷. • The repair, rehabilitation, or replacement of those structures or fills destroyed or damaged by storms, floods, fire or other discrete events is authorized, provided the repair, rehabilitation, or replacement is commenced, or is under contract to commence, within two years of the date of their destruction or damage. 	<p>1. Replacement of non-serviceable structures and fills or repair/maintenance of serviceable structures or fills, with fill, replacement or expansion <1 acre, or with a change in use.</p> <p>2. <1 acre temporary or permanent fill, excavation and/or secondary impacts. Fill area includes all temporary and permanent waterway fills, provided:</p> <ul style="list-style-type: none"> • Temporary or permanent fill in eelgrass¹⁴ <1000 SF. • Permanent fill in SAS (excluding eelgrass¹⁴) <4300 SF. <p>3. Standard Pile Driving Conditions. Work involving piles shall adhere to one of the four methods below:</p> <ul style="list-style-type: none"> • Piles installed in-the-dry during low water or in-water between Nov. 8th - Apr. 9th, or • Must be drilled and pinned to ledge, or • Vibratory hammers used to install any size and quantity of wood, concrete or steel piles, or • Impact hammers limited to one hammer and <50 piles installed/day with the following: wood piles of any size, concrete piles ≤18-inches diameter, steel piles <12-inches diameter if the hammer is ≤3000 lbs and a wood cushion is used between the hammer and steel pile, and • For the methods above: <ul style="list-style-type: none"> ○ In-water noise levels shall not exceed >187dB cSEL re 1μPa or 206dB peak re 1μPa at a distance >10m from the pile being installed, and ○ In-water noise levels >150dB peak re 1μPa shall not exceed 12 consecutive hours on any given day and a 12 hour recovery period (i.e., in-water noise below 150dB peak re 1μPa) must be provided between work days. • Existing derelict, degraded or abandoned piles in the project area that are affected by project activities should be removed and properly disposed of in an upland location landward of MHW or OHW and not in wetlands, tidal wetlands, their substrate or mudflats.

<p>2. Moorings</p>	<p>1. Private, non-commercial, non-rental, single-boat moorings, provided:</p> <ul style="list-style-type: none"> • Authorized by the local harbormaster/town. • Not associated with any boating facility.¹¹ • Boat or mooring not located in a Federal Navigation Project or buffer zone¹² other than in a Federal Anchorage¹². Moorings in a Federal Anchorage not associated with a boating facility¹¹ and are not for rent. • No interference with navigation. • No new moorings located in SAS³. Prior to installation of moorings, a site-specific eelgrass survey should be conducted to document that eelgrass is not present. • When existing, authorized moorings in SAS³ are going to be replaced, they should be replaced with low impact mooring technology that prevents mooring chains from resting or dragging on the bottom substrate at all tides and helical anchors, or equivalent SAS protection systems where practicable. <p>2. Minor relocation of previously authorized moorings, provided:</p> <ul style="list-style-type: none"> • Authorized by the local harbormaster/town. • Not located in SAS³ • No interference with navigation. • Cannot be relocated into a Federal Navigation Project¹² other than a Federal Anchorage¹² <p>Note: <i>Cat 1 eligible moorings do not require SVNf.</i></p>	<p>1. Moorings associated with an existing boating facility¹¹. An eelgrass¹⁴ survey may be required.</p> <p>2. Moorings that don't meet the terms in Category 1 and don't require an Individual Permit. This includes private moorings with no harbormaster or means of local approval.</p> <p>3. Moorings located such that they, and/or vessels docked or moored at them, are within the buffer zone of the horizontal limits¹³ of a Federal Channel¹². (See Appendix H.) The buffer zone is equal to 3 times the authorized depth of that channel.</p> <p>4. An IP is required for moorings within the horizontal limits¹¹, or with moored vessels that extend, into the horizontal limits of a Federal Navigation Project¹², except those in Federal Anchorages¹².</p> <p><i>For 1-4 above, siting of new individual moorings in SAS³, including eelgrass¹⁴, should be avoided to the maximum extent practicable. If SAS³ cannot be avoided, plans should show elastic mooring systems that prevent mooring chains from resting or dragging on the bottom substrate at all tides and helical anchors, or equivalent SAS protection systems, where practicable. For moorings that appear to impact SAS, the Corps may require an eelgrass survey.</i></p>
<p>3. Structures, Floats and Lifts</p>	<p>1. Reconfiguration of existing authorized structures shall occur in-the-dry during low water.</p> <p>2. Minor relocation of previously authorized floats or moored floats/lobster cars, provided:</p> <ul style="list-style-type: none"> • Authorized by the local harbormaster/town. • Not located in SAS³. • No interference with navigation. • Cannot be relocated into a Federal Navigation Project¹² other than a Federal Anchorage¹². 	<p>1. New structures or floats, including floatways/skidways, built to access waterway (seasonal and permanent). Includes both pile supported and crib supported structures.</p> <p>2. Expansions to existing boating facilities¹¹</p> <ul style="list-style-type: none"> • <i>Pile-supported structures <400 SF, with attached floats totaling ≤200 SF.</i> • <i>Structures are ≤4' wide and have at least a 1:1 height:width ratio¹¹.</i> • <i>Floats supported a minimum of 18" above the substrate during all tides.</i> • <i>Structures & floats not located within 25' of any eelgrass⁸.</i> • <i>Moored vessels not positioned over SAS³.</i>

- *The Corps may require a letter of no objection from the abutter if structure is to be within 25 feet of the property line.*
 - *No structure extends across >25% of the waterway width at mean low water.*
 - *Not located within the buffer zone of the horizontal limits¹³ of a Corps Federal Navigation Project (FNP) (Appendix F). The buffer zone is equal to three times the authorized depth of that FNP.*
3. An Individual Permit is required for structures or floats, including floatways/skidways, located such that they and/or vessels docked or moored at them are within the horizontal limits¹³ of a Corps Federal Navigation Project¹² (see Appendix H).
 4. An Individual Permit is required for structures & floats associated with a new or previously unauthorized boating facility¹¹.
 5. Standard Pile Driving Conditions. Work involving piles shall adhere to one of the four methods below:
 - Piles installed in-the-dry during low water or in-water between Nov. 8th - Apr. 9th, or
 - Must be drilled and pinned to ledge, or
 - Vibratory hammers used to install any size and quantity of wood, concrete or steel piles, or
 - Impact hammers limited to one hammer and <50 piles installed/day with the following: wood piles of any size, concrete piles ≤18-inches diameter, steel piles <12-inches diameter if the hammer is ≤3000 lbs and a wood cushion is used between the hammer and steel pile, and
 - For the methods above:
 - In-water noise levels shall not exceed >187dB cSEL re 1μPa or 206dB peak re 1μPa at a distance >10m from the pile being installed, and
 - In-water noise levels >150dB peak re 1μPa shall not exceed 12 consecutive hours on any given day and a 12 hour recovery period (i.e., in-water noise below 150dB peak re 1μPa) must be provided between work days.
 - Existing derelict, degraded or abandoned piles in the project area that are affected by project activities should be removed and properly disposed of in an upland location landward of MHW or OHW and not in wetlands, tidal wetlands, their substrate or mudflats.

<p>4. Aids to Navigation and Temporary Recreational Structures</p>	<p>1. Temporary buoys, markers, floats, etc. for recreational use during specific events, provided they are removed within 30 days after use is discontinued.</p> <p>2. The placement of aids to navigation and regulatory markers which are approved by and installed in accordance with the requirements of the U.S. Coast Guard. (See 33 CFR 66, Chapter I, subchapter C).”</p> <p><i>Note: Cat 1 eligible aids to navigation and regulatory markers do not require SVNF.</i></p>	<p>Work not eligible for Category 1</p>
<p>5. Dredging, Disposal of Dredged Material, Beach Nourishment, and Rock Removal and Relocation</p>	<p>1. Maintenance dredging¹⁰ for navigational purposes <1,000 CY with upland disposal. Includes return water from upland contained disposal area, provided:</p> <ul style="list-style-type: none"> • Proper siltation controls are used. • Dredging & disposal operation limited to Nov. 8 – Apr. 9. • No impact to SAS³. • No dredging in intertidal areas. • No dredging within 100’ of shellfish beds. • No dredging in areas designated as Critical Habitat for Atlantic salmon [see GC 8(b) & (c)]. • For dredging in tidal waters outside of Atlantic salmon critical habitat, applicants must contact NMFS (see GC 8) to ensure no impacts to listed species such as shortnose sturgeon, Atlantic surgeon, and listed sturgeon critical habitat. • Project proponents must contact the USFWS for work on coastal beaches to ensure no impacts to piping plovers, roseate terns, rufa red knot, or their habitat [see GC 8(c)]. • No underwater blasting. <p>2. Maintenance dredging is not eligible for Category 1 if conducted in tidal portions of the Penobscot river upstream of a line extending from Turner Point in Castine to Moose Point (formerly Squaw Point) on Cape Jellison in Stockton Springs or in tidal portions of the Kennebec or Androscoggin Rivers upstream of a line extending from Doubling Point in Arrowsic to Hospital Point in West Bath.</p>	<p>1. Maintenance dredging¹⁰ ≥1,000 CY, new dredging <25,000 CY, or projects not meeting Category 1. Includes return water from upland contained disposal areas. Disposal includes:</p> <ul style="list-style-type: none"> • Upland. • Beach nourishment (above mean high water) of any area provided the dredging’s primary purpose is navigation or the sand is from an upland source. • Open water & confined aquatic disposal, if Corps finds the material suitable. <p>2. Beach nourishment associated with dredging when the primary purpose is not navigation requires at least a Category 2 review.</p> <p>3. Maintenance or new dredging¹⁰ and/or disposal in or affecting a SAS³ requires an Individual Permit.</p>

<p>6. Discharges of Dredged or Fill Material Incidental to the Construction of Bridges</p>	<p>1. Discharges of dredged or fill material incidental to the construction of bridges across navigable waters of the U.S., including cofferdams, abutments, foundation seals, piers, and temporary construction and access fills provided the U.S. Coast Guard authorizes such discharges as part of the bridge permit or appropriate approval. 2. Causeways and approach fills are not included in this category and require Category 2 or Individual Permit authorization.</p>	<p><1 acre temporary or permanent fill, excavation and/or secondary impacts (e.g., areas drained, flooded, fragmented or mechanically cleared). Fill area includes all temporary and permanent waterway fills, provided:</p> <ul style="list-style-type: none"> • Temporary or permanent fill in eelgrass¹⁴ <1000 SF. • Permanent fill in SAS (excluding eelgrass¹⁴) <4300 SF.
<p>7. Bank and Shoreline Stabilization</p>	<p>1. Bank stabilization projects <200 linear feet provided:</p> <ul style="list-style-type: none"> • ≤1 cubic yard of fill per linear foot placed along the bank waterward of high tide line. No fill or equipment will occur in SAS³. • Work conducted in the intertidal zone must be conducted in-the-dry during low water. • No structures angled steeper than 1H:1V and only rough-faced stone or fiber roll revetments allowed. • No driving of piles or sheeting. <p>2. Bank stabilization projects in excess of 200 linear feet (Applicant or Applicant + Abutters combined) must undergo Category 2 review.</p>	<p>1. Work not eligible for Category 1. 2. <1 acre temporary or permanent fill, excavation and/or secondary impacts (e.g., areas drained, flooded, fragmented or mechanically cleared). Fill area includes all temporary and permanent waterway fills, provided:</p> <ul style="list-style-type: none"> • Temporary or permanent fill in eelgrass¹⁴ <1000 SF. • Permanent fill in SAS (excluding eelgrass¹⁴) <4300 SF.
<p>8. Residential, Commercial, and Industrial Developments, and Recreational Facilities</p>	<p>Not Eligible</p>	<p>1. <1 acre temporary or permanent fill, excavation and/or secondary impacts (e.g., areas drained, flooded, fragmented or mechanically cleared). Fill area includes all temporary and permanent waterway fills, provided:</p> <ul style="list-style-type: none"> • Temporary or permanent fill in eelgrass¹⁴ <1000 SF. • Permanent fill in SAS (excluding eelgrass¹⁴) <4300 SF. <p>2. Conversions of previously authorized pile supported buildings over navigable waters to residences, offices, or other non-water dependent uses require at least a Category 2 review. 3. Floating house boats or businesses on floats require Category 2 review.</p>
<p>9. Utility Line Activities</p>	<p>1. Repair or maintenance of existing, currently serviceable, authorized utilities with no expansion or change in use:</p> <ul style="list-style-type: none"> • Conditions of the original authorization apply. • Trenching or filling is confined to the existing footprint. • In water work conducted between Nov 8 and Apr 9. • No new impact to SAS. <p>2. Particularly relevant is GC12. 3. <u>New work in, over, or under navigable waters</u> requires a PCN and Category 2 review. 4. Except for aerial utility lines, work is not eligible for Category 1 if conducted in tidal portions of the Penobscot River upstream of a line extending from Turner Point in Castine to Moose Point (formerly</p>	<p>1. New or replacement installations or work not otherwise eligible for Category 1. 2. <1 acre temporary or permanent fill, excavation and/or secondary impacts (e.g., areas drained, flooded, fragmented or mechanically cleared). Fill area includes all temporary and permanent waterway fills, provided:</p> <ul style="list-style-type: none"> • Temporary or permanent fill in eelgrass¹⁴ <1000 SF. • Permanent fill in SAS (excluding eelgrass¹⁴) <4300 SF. <p>3. Particularly relevant is GC12</p>

	Squaw Point) on Cape Jellison in Stockton Springs or in tidal	
10. Linear Transportation Projects (Not Including Stream Crossings)	Not eligible	<p><1 acre temporary or permanent fill, excavation and/or secondary impacts (e.g., areas drained, flooded, fragmented or mechanically cleared). Fill area includes all temporary and permanent waterway fills, provided:</p> <ul style="list-style-type: none"> • Temporary or permanent fill in eelgrass¹⁴ <1000 SF. • Permanent fill in SAS (excluding eelgrass¹⁴) <4300 SF.
11. Mining Activities	Not Eligible	Not Eligible
12. Boat Ramps and Marine Railways	<ol style="list-style-type: none"> 1. No new impact to SAS 2. Marine railway and boat ramp work not eligible for maintenance⁷ (i.e. not currently serviceable⁷) may be replaced “in-kind” with minor deviations⁷ provided: <ul style="list-style-type: none"> • Work is in the intertidal zone. • No fill expansion below high tide line. • Work conducted in-the-dry during low water. 3. No new boat ramps or marine railways. 	<ol style="list-style-type: none"> 1. Work not eligible for Category 1 2. <1 acre temporary or permanent fill, excavation and/or secondary impacts (e.g., areas drained, flooded, fragmented or mechanically cleared). Fill area includes all temporary and permanent waterway fills, provided: <ul style="list-style-type: none"> • Temporary or permanent fill in eelgrass¹⁴ <1000 SF. • Permanent fill in SAS (excluding eelgrass¹⁴) <4300 SF.
13. Land and Water-Based Renewable Energy Generation Facilities and Hydropower Projects	Not Eligible	<ol style="list-style-type: none"> 1. <1 acre temporary or permanent fill, excavation and/or secondary impacts (e.g., areas drained, flooded, fragmented or mechanically cleared). Fill area includes all temporary and permanent waterway fills, provided: <ul style="list-style-type: none"> • Temporary or permanent fill in eelgrass¹⁴ <1000 SF. • Permanent fill in SAS (excluding eelgrass¹⁴) <4300 SF. 2. No new impoundments.
14. Reshaping Existing Drainage Ditches and Mosquito Management	<ol style="list-style-type: none"> 1. ≤500 linear feet of drainage ditch will be modified. The reshaping of the ditch cannot increase drainage capacity beyond the original as-built capacity nor can it expand the area drained by the ditch as originally constructed (i.e., the capacity of the ditch must be the same as originally constructed and it cannot drain additional wetlands or other waters of the U.S.). 2. No new ditches or relocation of drainage ditches constructed in waters of the U.S.; the location of the centerline of the reshaped drainage ditch must be approximately the same as the location of the centerline of the original drainage ditch. 3. No effect on federally listed endangered or threatened species or critical habitat 	<ol style="list-style-type: none"> 1. Work not eligible for Category 1 2. <1 acre temporary or permanent fill, excavation and/or secondary impacts (e.g., areas drained, flooded, fragmented or mechanically cleared). Fill area includes all temporary and permanent waterway fills, provided: <ul style="list-style-type: none"> • Temporary or permanent fill in eelgrass¹⁴ <1000 SF. • Permanent fill in SAS (excluding eelgrass¹⁴) <4300 SF.

<p>15. Oil Spill and Hazardous Material Cleanup</p>	<p>Jurisdictional activities required for the containment and cleanup of oil and hazardous substances that are subject to the National Oil and Hazardous Substances Pollution Contingency Plan (40 CFR 300) provided that the work is done in accordance with the Spill Control and Countermeasure Plan required by 40 CFR 112.3 and any existing state contingency plan and provided that the Regional Response Team (if one exists in the area) concurs with the proposed containment and cleanup action. SAS³ must typically be restored in place at the same elevation.</p> <p><i>Note: SVNf or a surrogate state reporting form may be submitted after the fact. No SVNf is required for Category 1 eligible containment booms.</i></p>	<p>Work not eligible for Category 1</p>
<p>16. Cleanup of Hazardous and Toxic Waste</p>	<p>Not eligible - except for booms placed for hazardous and toxic waste containment and absorption and prevention which are eligible for SV.</p> <p><i>Note: No SVNf is required for Category 1 eligible containment booms.</i></p>	<p>Specific jurisdictional activities with impacts of any area required to affect the containment, stabilization, or removal of hazardous or toxic waste materials that are performed, ordered, or sponsored by a government agency with established legal or regulatory authority. Wetlands and other SAS must typically be restored in place at the same elevation to qualify.</p>
<p>17. Scientific Measurement Devices</p>	<p>Scientific measurement devices whose purpose is to measure and record scientific data, such as staff gages, water recording devices, water quality testing and improvement devices, and similar structures. Structures may not restrict or concentrate movement of aquatic organisms; no activity results in a hazard to navigation; and no activity requiring underwater blasting.</p>	<p>1. Work not eligible for Category 1 2. <1 acre temporary or permanent fill, excavation and/or secondary impacts (e.g., areas drained, flooded, fragmented or mechanically cleared). Fill area includes all temporary and permanent waterway fills, provided:</p> <ul style="list-style-type: none"> • Temporary or permanent fill in eelgrass¹⁴ <1000 SF. • Permanent fill in SAS (excluding eelgrass¹⁴) <4300 SF.
<p>18. Survey Activities</p>	<p>Jurisdictional survey activities such as exploratory drilling, surveying and sampling activities, excluding any biological sampling devices. Does not include any activity requiring underwater blasting, seismic exploratory operations, or oil and gas exploration and fill for roads or construction pads. No activity may result in a hazard to navigation.</p>	<p>1. Work not eligible for Category 1 2. <1 acre temporary or permanent fill, excavation and/or secondary impacts (e.g., areas drained, flooded, fragmented or mechanically cleared). Fill area includes all temporary and permanent waterway fills, provided:</p> <ul style="list-style-type: none"> • Temporary or permanent fill in eelgrass¹⁴ <1000 SF. • Permanent fill in SAS (excluding eelgrass¹⁴) <4300 SF.
<p>19. Agricultural Activities</p>	<p>Not Eligible</p>	<p>Not Eligible</p>

<p>20. Fish & Wildlife Harvesting, Enhancement and Attraction Devices and Activities (Not Aquaculture)</p>	<p>Fish and wildlife harvesting, enhancement, and attraction devices and activities such as pound nets, crab traps, crab dredging, eel pots, lobster traps, and clam and oyster digging, and small fish attraction devices such as open water fish concentrators (sea kites, etc.). This does not authorize artificial reefs or impoundments and semi-impoundments of waters of the U.S. for the culture or holding of motile species such as lobster, or the use of covered oyster trays or clam racks. No activity that may result in a hazard to navigation. <i>Note: A SVNF is not required for these Category 1 eligible devices and activities.</i></p>	<p>1. Work not eligible for Category 1. 2. Impoundments or semi-impoundments of waters of the U.S. for the culture or holding of motile species such as lobster and new fish weirs with an impounded area \leq 1/2 acre. For Aquaculture operations, refer to Activity 24.</p>
<p>21. Habitat Restoration, Establishment and Enhancement Activities</p>	<p>1. Cultch placement in tidal waters is eligible for SV provided there are no salt marsh or vegetated shallow impacts. 2. SAS planting and transplanting \leq 100 SF in tidal waters; 3. No artificial or living reefs. 4. The activity is authorized in writing by a local, state, or non-Corps federal environmental agency. Water impoundments require PCN. 5. No conversion of i) a stream to wetland or vice versa, wetland to a pond or uplands, and ii) one wetland type to another. 6. No dam removal. 7. Shellfish habitat enhancement such as brushing the flats is eligible for Category 1, but not the use of netting which requires Category 2 review.</p>	<p>1. Work not eligible for Category 1. 2. Aquatic habitat restoration, establishment and enhancement provided those activities are proactive and result in net increases in aquatic resource functions and services.⁸</p>
<p>22. Previously Authorized Activities</p>	<p>Any work not commenced nor completed that was authorized in a written letter from the Corps under the GP in effect between October 12, 2010 and October 12, 2015. The terms and general conditions of this GP apply along with any special conditions in the written authorization.</p>	
<p>23. Stream & Wetland Crossings</p>	<p>Not Eligible</p>	<p>All temporary or permanent crossings of tidal navigable waters or adjacent tidal wetlands not eligible as maintenance require a PCN. GC 45 applies</p>
<p>24. Aquaculture</p>	<p>Not Eligible</p>	<p>Shellfish & finfish aquaculture (with the exception of Atlantic salmon and any other salmonid, or other federally listed endangered or threatened species), or other aquaculture facilities with no more than minimal individual and cumulative impacts to environmental resources or navigation. This is inclusive but not limited to cages, nets, bags, racks, long lines, fences, posts, poles, predator screening, etc. Aquaculture guidelines are provided at: www.maine.gov/dmr/aquaculture/index.htm.</p>

Endnotes/Definitions

¹ Bordering and Contiguous Wetlands: A bordering wetland is immediately next to its adjacent waterbody and may lie at, or below, the ordinary high water mark (mean high water in navigable waters) of that waterbody and is directly influenced by its hydrologic regime. Contiguous wetlands extend landward from their adjacent waterbody to a point where a natural or manmade discontinuity exists. Contiguous wetlands include bordering wetlands as well as wetlands that are situated immediately above the ordinary high water mark and above the normal hydrologic influence of their adjacent waterbody. Note, with respect to the federally designated navigable rivers, the wetlands bordering and contiguous to the tidally influenced portions of those rivers are reviewed under “II. Navigable Waters.”

² Direct, Secondary, and Cumulative Impacts/Effects:

Direct Impacts: The immediate loss of aquatic ecosystem within the footprint of the fill.

Secondary Impacts: These are effects on an aquatic ecosystem that are associated with a discharge of dredged or fill materials, but do not result from the actual placement of the dredged or fill material. Information about secondary effects on aquatic ecosystems shall be considered prior to the time final section 404 action is taken by permitting authorities. Some examples of secondary effects on an aquatic ecosystem are a) fluctuating water levels in all impoundment and downstream associated with the operation of a dam, b) septic tank leaching and surface runoff from residential or commercial developments on fill, and c) leachate and runoff from a sanitary landfill located in waters of the U.S. Put another way, secondary effects are those impacts outside the footprint of the fill that arise from and are associated with the discharge of dredged or fill material, including the operation of an activity or facility associated with the discharge. Examples may include habitat fragmentation; interruption of travel corridors for wildlife (for example, for amphibians that migrate to and from seasonal or vernal pools used as breeding habitat); hydrologic regime changes; and impacts from operation and maintenance activities for constructed facilities; such as noise/lighting, storm water runoff, and road kill of wetland dependent wildlife. Using the directions contained in the guidelines, we consider the circumstances of a proposed discharge and the project of which it is a part to evaluate the scope, extent, severity, and permanence of direct, secondary, and cumulative adverse effects upon the aquatic ecosystem.

Cumulative Impacts: The extent of past, present, and foreseeable developments in the area may be an important consideration in evaluating the significance of a particular project’s impacts. Although the impacts associated with a particular discharge may be minor, the cumulative effect of numerous similar discharges can result in a large impact. Cumulative impacts should be estimated only to the extent that they are reasonable and practical.

³ Special Aquatic Sites: Includes wetlands and saltmarsh, mudflats, riffles and pools, and vegetated shallows (predominantly comprised of eelgrass in Maine).

⁴ Construction Mats: Constructions, swamp and timber mats (herein referred to as “construction mats”) are generic terms used to describe structures that distribute equipment weight to prevent wetland damage while facilitating passage and providing work platforms for workers and equipment. They are comprised of sheets or mats made from a variety of materials in various sizes. A timber mat consists of large timbers bolted or cabled together. Corduroy roads, which are not considered to be construction mats, are cut trees and/or saplings with the crowns and branches removed, and the trunks lined up next to one another. Corduroy roads are typically installed as permanent structures. Like construction mats, they are considered as fill whether they’re installed temporarily or permanently.

⁵ Vernal Pools: A vernal pool, also referred to as a seasonal forest pool, is a temporary to semi-permanent body of water occurring in a shallow depression that typically fills during the spring or fall and may dry during the summer. Vernal pools have no permanent inlet or outlet and no viable populations of predatory fish. A vernal pool may provide the primary breeding habitat for wood frogs (*Rana sylvatica*), spotted salamanders (*Ambystoma maculatum*), blue-spotted salamanders (*Ambystoma laterale*), and fairy shrimp (*Eubranchipus* sp.), as well as valuable habitat for other plants and wildlife, including several rare, threatened, and endangered species. A vernal pool intentionally created for the purposes of compensatory mitigation is included in this definition. For the purposes of this GP, the presence of any of the following species in any life stage in any abundance level/quantity would designate the waterbody as a vernal pool: fairy shrimp, blue spotted salamanders, spotted salamanders or wood frogs. The Corps may determine during a Category 2 review that a waterbody should not be regulated as a VP based on available evidence. For the purposes of this GP, the VP Management Areas are the: Vernal Pool Depression (includes the vernal pool depression up to the spring or fall high water mark, and includes any vegetation growing within the depression), Vernal Pool Envelope (area within 100 FT of the VP Depression’s edge) and Critical Terrestrial Habitat (area within 100-750 FT of the Vernal Pool Depression’s edge). [*Note: Critical Terrestrial Habitat is defined as 100 -750 FT on page 243 of the document “Science and Conservation of Vernal Pools in Northeastern North America.” Calhoun and deMaynadier, 2008, which is referenced in Appendix G, page 3, Paragraph 10(b).

⁶ **Water Diversions:** Water diversions are activities such as bypass pumping or water withdrawals. Temporary flume pipes, culverts or cofferdams where normal flows are maintained within the stream boundary's confines aren't water diversions. "Normal flows" are defined as no change in flow from pre-project conditions.

⁷ **Maintenance:** a) The repair, rehabilitation, or replacement of any previously authorized, currently serviceable structure or fill, or of any currently serviceable structure or fill authorized by 33 CFR 330.3 – "Activities occurring before certain dates," provided that the structure or fill is not to be put to uses differing from those uses specified or contemplated for it in the original permit or the most recently authorized modification.

- Minor deviations in the structure's configuration or filled area, including those due to changes in materials, construction techniques, or current construction codes or safety standards that are necessary to make repair, rehabilitation, or replacement are authorized.
- Currently serviceable means useable as is or with some maintenance, but not so degraded as to essentially require reconstruction.
- No seaward expansion for bulkheads or any other fill activity is considered Category 1 maintenance.
- Only structures or fills that were previously authorized and are in compliance with the terms and condition of the original authorization can be maintained as a non-regulated activity under 33 CFR 323.4(a)(2), or in accordance with the Category 1 or 2 thresholds in Appendix A.

b) The state's maintenance provisions may differ from the Corps and may require reporting and written authorization from the state.

c) Contact the Corps to determine whether stream crossing replacements require a written application to the Corps for at least a Category 2 review.

d) Exempted Maintenance. In accordance with 33 CFR 323.4(a)(2), any discharge of dredged or fill material that may result from any of the following activities is not prohibited by or otherwise subject to regulation under Section 404 of the CWA: "Maintenance, including emergency reconstruction of recently damaged parts, of currently serviceable structures such as dikes, dams, levees, groins, riprap, breakwaters, causeways, bridge abutments or approaches, and transportation structures. Maintenance does not include any modification that changes the character, scope, or size of the original fill design."

⁸ **Aquatic Habitat Restoration, Establishment and Enhancement:** The Corps will decide if a project qualifies and must determine in consultation with federal and state agencies that the net effects are beneficial. The Corps may refer to Nationwide Permit 27 published in the 3/12/07 Federal Register. Activities authorized here may include, but are not limited to: the removal of accumulated sediments; the installation, removal, and maintenance of small water control structures, dikes, and berms; the installation of current deflectors; the enhancement, restoration, or establishment of riffle and pool stream structure; the placement of in-stream habitat structures; modifications of the stream bed and/or banks to restore or establish stream meanders; the backfilling of artificial channels and drainage ditches; the removal of existing drainage structures; the construction of small nesting islands in inland waters; the construction of open water areas; the construction of native shellfish species habitat over unvegetated bottom for the purpose of habitat protection or restoration in tidal waters; shellfish seeding; activities needed to reestablish vegetation, including plowing or discing for seed bed preparation and the planting of appropriate wetland species; mechanized land clearing to remove non-native invasive, exotic, or nuisance vegetation; and other related activities. Only native plant species should be planted at the site.

⁹ **Brushing the Flats:** The placement of tree boughs, wooden lath structure, or small-mesh fencing on mudflats to enhance recruitment of soft-shell clams (*Mya arenaria*).

¹⁰ **Maintenance Dredging:** This includes only those areas and depths previously authorized by the Corps and dredged. The Corps may require proof of authorization. Maintenance dredging typically refers to the routine removal of sediment to maintain the design depths of serviceable navigation channels, harbors, basins, marinas, boat launches, and port facilities. Maintenance dredging is conducted for navigational purposes and does not include any expansion of the previously dredged area or depth. The Corps may review a maintenance dredging activity as new dredging if sufficient time has elapsed to allow for the colonization of SAS, shellfish, etc.

¹¹ **Boating Facilities:** Facilities that provide for a fee, rent, or sell mooring space, such as marinas, yacht clubs, boat clubs, boat yards, town facilities, dockominiums, etc.

¹² **Federal Navigation Projects (FNPs):** FNPs are comprised of Federal Channels and Federal Anchorages. See Appendix F for their location and contact the Corps for more information. "Horizontal Limits" is the outer edge of an FNP. "Buffer Zone" is equal to three times the authorized depth of that channel.

¹³ **Horizontal Limits:** The outer edge of a Federal Navigation Project (FNP). See Appendix F and contact the Corps for information on FNP's.

¹⁴ **Eelgrass (*Zostera marina*):** A type of rooted aquatic vegetation that exists in intertidal and shallow subtidal areas known as vegetated shallows. See www.nero.noaa.gov/hcd/ for eelgrass survey guidance. Note: Eelgrass surveys should be conducted between May and October unless otherwise directed.

¹⁵ **Structures:** The height of structures shall at all points be equal to or exceed the width of the deck. For the purpose of this definition, height shall be measured from the marsh substrate to the bottom of the longitudinal support beam.

¹⁶ **Agricultural Activities:** The Clean Water Act exempts certain discharges associated with normal farming, ranching, and forestry activities such as plowing, cultivating, minor drainage, and harvesting for the production of food, fiber, and forest products, or upland soil and water conservation practices (Section 404(f)(1)(A)). Applicants are strongly advised to contact the Corps for a determination of whether their activity is exempt or requires a permit.



Appendix B: Self-Verification Notification Form
(for all tidal and non-tidal projects in Maine subject to Corps jurisdiction)

**US Army Corps
of Engineers**®
New England District

At least two weeks before work commences, complete **all** fields (write “none” if applicable) below or use the fillable form at www.nae.usace.army.mil/missions/regulatory.aspx. Send this form, a location map, any project plans, and an Official Species List (See GC 8) to the address noted below; fax to (207) 623-8206; or email to jay.l.clement@usace.army.mil. The two-week lead time is not required for emergency situations (see page 4 for definition). Please call (207) 623-8367 with questions.

Maine Project Office
U.S. Army Corps of Engineers
New England District
675 Western Avenue #3
Manchester, Maine 04351

State Permit Number: _____
Date of State Permit: _____
State Project Manager: _____

Permittee: _____
Address, City, State & Zip: _____
Phone(s) and Email: _____

Contractor: _____
Address, City, State & Zip: _____
Phone(s) and Email: _____

Consultant/Engineer/Designer: _____
Address, City, State & Zip: _____
Phone(s) and Email: _____

Wetland/Vernal Pool Consultant: _____
Address, City, State & Zip: _____
Phone(s) and Email: _____

Project Location/Description: _____
Address, City, State & Zip: _____
Latitude/Longitude Coordinates: _____ Tax Map/Lot: _____
Waterway Name: _____
Work Description: _____

Provide any prior Corps permit numbers: _____
Proposed Work Dates: Start: _____ Finish: _____

Area of wetland impact: _____ SF (leave blank if work involves structures & no fill in Navigable Waters)
Area of waterway impact: _____ SF (leave blank if work involves structures & no fill in Navigable Waters)
Area of compensatory mitigation provided: _____ SF

Work will be done under the following Appendix A categories (circle all that apply):
I. Inland Waters and wetlands: 1 2 3 4 5 6 7 8 9 10 11 12 13 14 15 16 17 18 19 20 21 22 23 24
II. Navigable Waters: 1 2 3 4 5 6 7 8 9 10 11 12 13 14 15 16 17 18 19 20 21 22 23 24

Your name/signature below, as permittee, indicates that you accept and agree to comply with the terms, eligibility criteria, and general conditions of Category 1 of the Maine General Permit.

Permittee Printed Name: _____
Permittee Signature: _____ Date: _____



**US Army Corps
of Engineers®**
New England District

Appendix C: Content of Pre-Construction Notification

In addition to the following required information, the applicant must provide additional information as the Corps deems essential to make a public interest determination including, where applicable, a determination of compliance with the Section 404(b)(1) guidelines or ocean dumping criteria. Such additional information may include environmental data and information on alternate methods and sites as may be necessary for the preparation of the required environmental documentation. For a more comprehensive checklist, go to www.nae.usace.army.mil/missions/regulatory >> Forms >> Application and Plan Guideline Checklist. Please check with the Corps for project-specific requirements.

Information required for all projects:

- Corps application form ([ENG Form 4345](#)) or appropriate state application form (see Appendix E). Forms may need to be supplemented to include the information noted below.
- Proof of notification to the SHPO and the appropriate THPOs (see Appendix E).
- Official Species List for any federally listed endangered or threatened species (Instructions at Appendix D)
- Drawings, sketches, or plans (detailed engineering plans and specifications are not required) that are legible, reproducible (color is encouraged, but features must be distinguishable in black and white), no larger than 11"x17", with bar scale. Wetland area impact sheets should have the highest resolution possible to show work within Corps jurisdiction (do not just reduce project overview or cut large-scale plan into quadrant sheets). Provide locus map and a plan overview of the entire property with a key index to the individual impact sheets. A locus map be on a section of color USGS topographic map is encouraged. Digital submissions are encouraged.
- Include:
 - All direct, secondary, permanent and temporary effects the project would cause, including the anticipated amount of impacts to waters of the U.S. expected to result from the activity, in acres, linear feet, or other appropriate unit of measure.
 - Any historic permanent fill associated with each single and complete project.
 - Cross-section views of all wetland and waterway fill areas and wetland replication areas.
 - Delineation of all wetlands, other special aquatic sites (vegetated shallows, saltmarsh, mudflats, riffles and pools, coral reefs, and sanctuaries and refuges), and other waters, such as lakes and ponds, and perennial, intermittent, and ephemeral streams, on the project site. Use Federal delineation methods and include Corps wetland delineation data sheets (see GC 2).
 - MLW and MHW elevations in tidal waters. Show the HTL elevations when fill is involved. Show OHW elevation in lakes and non-tidal streams.
 - Existing and proposed conditions.
 - For vegetated shallow and eelgrass survey guidance, see www.nae.usace.army.mil/missions/regulatory >> Jurisdictional Limits and Wetlands >> Submerged Aquatic Vegetation Survey Guidance for the New England Region.
 - Show all known VPs on the project site. See GC 23 for vernal pool identification requirements.
- Volume, type, and source of fill material to be discharged into waters and wetlands, including the area(s) (in square feet or acres) of fill in wetlands, below OHW in inland waters and below the HTL in coastal waters.

- An Official Species List of federally “listed species or critical habitat” present in the action area (see GC 8).
- A restoration plan showing how all temporary fills and structures will be removed and the area restored to pre-project conditions (see GC 43).

Information that may be required:

- Photographs of wetland/waterway to be impacted. Photos at low tide are preferred for work in tidal waters.
- For drawings, sketches, or plans:
 - The vertical datum for all coastal projects must be in U.S. survey feet and referenced to MLLW and current tidal epochs, with a reference chart showing conversion factor to NAVD88; do not use local datum. See www.nae.usace.army.mil/missions/regulatory >> Forms and Publications >>Vertical Datum - FEMA (Jul 2007);
 - The horizontal state plane coordinates shall be in U.S. survey feet and based on the appropriate state plane coordinate system.
- For the construction of a filled area or pile or float-supported platform, the use of, and specific structures to be erected on, the fill or platform.
- For the discharge of dredged or fill material into waters of the U.S. or the transportation of dredged material for the purpose of disposing of it in ocean waters, the source of the material; the purpose of the discharge, a description of the type, composition and quantity of the material; the method of transportation and disposal of the material; and the location of the disposal site.
- For the discharge of dredged or fill material into waters of the U.S., include a statement describing how impacts to waters of the U.S. are to be avoided and minimized. Include either a statement describing how impacts to waters of the U.S. are to be compensated for or a statement explaining why compensatory mitigation should not be required for the proposed impacts.
- Purpose and need for the proposed activity;
- Limits and coordinates of any Federal Navigation Project in the vicinity of the project area.
- Limits and coordinates of any proposed mooring field, reconfiguration zone or aquaculture activity. Provide coordinates for all corners;
- Schedule of construction/activity;
- Names and addresses of adjoining property owners;
- Location and dimensions of adjacent structures;
- List of authorizations required by other Federal, interstate, state, or local agencies for the work, including all approvals received or denials already made.
- Identification and description of potential impacts to Essential Fish Habitat (defined at VI. Definitions and Acronyms).
- Identification of potential discharges of pollutants to waters, including potential impacts to impaired waters, in the project area (see GC 19).
- Invasive Species Control Plan (see GC 24). For sample control plans, see www.nae.usace.army.mil/missions/regulatory >> Invasive Species.
- Wildlife Action Plan (WAP) maps. Contact Maine Inland Fisheries & Wildlife (Appendix E) or on line at http://www.maine.gov/ifw/wildlife/conservation/action_plan.html

Information for dredging projects that may be required:

- Sediment testing, including physical (e.g., grain-size analysis), chemical and biological testing. For projects proposing open water disposal, applicants are encouraged to contact the Corps as early as possible regarding sampling and testing protocols. Sampling and testing of sediments without such contact should not occur and if done, would be at the applicant’s risk.
- The area in square feet and volume of material to be dredged below mean high water.

- Existing and proposed water depths.
- Type of dredging equipment to be used.
- Nature of material (e.g., silty sand).
- Any existing sediment grain size and bulk sediment chemistry data for the proposed or any nearby projects.
- Information on the location and nature of municipal or industrial discharges and occurrence of any contaminant spills in or near the project area.
- Shellfish survey.
- Location of the disposal site (include locus sheet).
- Identification and description of any potential impacts to Essential Fish Habitat.
- Delineation of submerged aquatic vegetation (e.g., eelgrass beds).

Information for aquaculture projects that may be required:

- Maine Aquaculture guidelines and joint Corps/Maine DMR applications may be found at: www.maine.gov/dmr/aquaculture/index.htm.
- In addition to the information required above, applications must also include:
 - Whether canopy predator nets are being used.

Appendix D: Instruction for USFWS IPaC Project Builder/Official Species List

NOTE: These instructions are subject to change by the USFWS. Users should check this GP's Corps webpage for the latest instructions or click [here](#).

In your internet browser go to <http://ecos.fws.gov/ipac/>

1. Click on get started.
2. Click on enter project location.
3. Search or zoom to your project location. (You can enter an address and then zoom in with your mouse).
4. Define your area. (Select the polygon tool and click around the boundary of your project.) or (Use the draw a line tool for linear projects)

Note: You can change/select the map from Streets to Satellite or Topo in the lower left corner of the map.

5. Click finished drawing then click confirm and select continue.

6. On the next page under Tasks (lower left), select Request an official species list. The pane will open. Select "request official species list" again.

7. A new page will open. Fill in the project information blanks with the project name, brief description, project type, lead agency, and contact information. Be sure to check the box to verify this is a legitimate project. Click on Submit Official Species List Request.

8. You will be sent an e-mail with instructions to complete the request by clicking on the link provided.

9. The site will open Official Species List Request Completed. Under the Maine Ecological Services Field Office address you will see "Official Species List Document". Click on that link and your document will open. Save and or print a copy and **include the entire report with your application.**

Note, you will receive a second e-mail with the same information. You can save the link in the event you need to return to the IPaC site for an updated list.

If a period of time has passed since your initial "Official Species List" identifier number was generated, you may choose to generate an "UPDATED SPECIES LIST". To do this, return to the IPaC homepage at <http://ecos.fws.gov/ipac> site. In the middle of the page, click the purple "Need an updated species list" link.

On the request an "Updated Official Species List" page, complete the information in the boxes provided. You will need the project specific official consultation code generated and stated on the original official list as well as the email address entered with the original submission.

Click "Request Updated Species List". Print, or save.

Appendix E: Contacts and Tribal Areas of Interest

1. Federal

U.S. Army Corps of Engineers
Maine Project Office
675 Western Avenue #3
Manchester, ME 04351
(207) 623-8367 (phone); (207) 623-8206 (fax)

Federal Emergency Management Agency
99 High St.
Boston, MA 02110
(877) 336-2734 (phone)
(Flood Plain Management)

U.S. Environmental Protection Agency
5 Post Office Square
Suite 100 (OEP05-2)
Boston, MA 02109-3912
(617) 918-1589 (phone)

National Marine Fisheries Service
55 Great Republic Drive
Gloucester, MA 01930
(978) 281-9102 (phone); (978) 281-9301 (fax)
(Federal endangered species & EFH)

U.S. Fish and Wildlife Service
Maine Field Office
17 Godfrey Drive, Suite 2
Orono, ME 04473
(207) 866-3344 (phone); (207) 866-3351 (fax)
(Federal endangered species)

National Park Service
North Atlantic Region
15 State Street
Boston, MA 02109
(617) 223-5203 (phone)
(Wild and Scenic Rivers)

National Marine Fisheries Service
Maine Field Office
17 Godfrey Drive Suite 1
Orono, ME 04473
(207) 866-7379 (phone); (207) 866-7342 (fax)
(Federal endangered species)

Commander (dpb)
First Coast Guard District
One South Street - Battery Bldg
New York, NY 10004-1466
(212) 668-7021 (phone); (212) 668-7967 (fax)
(bridge permits)

2. State of Maine

a. Department of Environmental Protection *(State permits & Water Quality Certifications)*

Division of Land Resource Regulation
Bureau of Land and Water Quality
17 State House Station
Augusta, Maine 04333
(207) 287-7688 (phone)

Eastern Maine Regional Office
106 Hogan Road
Bangor, Maine 04401
(207) 941-4570 (phone)

Southern Maine Regional Office
312 Canco Road
Portland, Maine 04103
(201) 822-6300 (phone)

Northern Maine Regional Office
1235 Central Drive - Skyway Park
Presque Isle, Maine 04769
(207) 764-0477 (phone)

b. Department of Agriculture, Conservation and Forestry

i. Maine Land Use Planning Commission (LUPC) (*State permits & Water Quality Certifications in the unorganized areas of the State*)

Augusta Office
22 State House Station
Augusta, Maine 04333-0022
(207) 287-2631 (phone); (207) 287-7439 (fax)

Greenville Regional Office
43 Lakeview Drive
P.O. Box 1107
Greenville, Maine 04441
(207) 695-2466 (phone); (207) 695-2380 (fax)

Rangley Regional Office
133 Fyfe Road
PO Box 307
West Farmington, ME 04992
(207) 670-7493 (phone); (207) 287-7439 (fax)

Downeast Regional Office
106 Hogan Rd, Suite 8
Dorothea Dix Complex
Bangor, Maine 04401
(207) 941-4052 (phone); (207) 941-4222 (fax)

Ashland Regional Office
45 Radar Road
Ashland, ME 04732-3600
(207) 435-7963 (phone); (207) 435-7184 (fax)

East Millinocket Regional Office
191 Main Street
East Millinocket, ME 04430
(207) 746-2244 (phone); (207) 746-2243 (fax)

ii. Maine Coastal Program

Department of Agriculture, Conservation and Forestry
Bureau of Resource Information and Land Use Planning
17 Elkins Lane {physical address}
State House Station 93
Augusta, Maine 04333-0038
(207) 287-2801 (phone); (207) 287-2353 (fax)
(*CZM consistency determinations*)

iii. Division of Parks and Public Lands

22 State House Station
Augusta, Maine 04333
(207) 287-3061 (phone); (207) 287-6170 (fax)
(*submerged lands leases*)

c. Department of Marine Resources

P.O. Box 8
West Boothbay Harbor, Maine 04575
(207) 633-9500 (phone); (207) 624-6024 (fax)
(*aquaculture leases*)

3. Historic Properties

a. State Historic Preservation Officer (SHPO)

Mr. Kirk F. Mohney, Director

Maine Historic Preservation Commission (MHPC)
65 State House Station
Augusta, Maine 04333-0065
(207) 287-2132 (phone); (207) 287-2335 (fax)
Area of concern: The entire State of Maine

b. Tribal Historic Preservation Officers (THPOs)

Note: The area of concern for each tribe is the entire State of Maine

THPO & Environmental Planner
Houlton Band of Maliseet Indians
88 Bell Road
Littleton, Maine 04730
(207) 532-4273, x215 (phone)
(207) 532-6883 (fax)
envplanner@maliseets.com
ogs1@maliseets.com

THPO
Aroostook Band of Micmacs
7 Northern Road
Presque Isle, Maine 04769
(207) 764-1972 (phone); (207) 764-7667 (fax)
jpictou@mimca-nsn.gov

THPO
Passamaquoddy Tribe of Indians
Pleasant Point Reservation
P.O. Box 343
Perry, Maine 04667
(207) 853-2600 (phone); (207) 853-6039 (fax)
soctomah@gmail.com

THPO
Penobscot Nation
Cultural and Historic Preservation Dept.
12 Wabanaki Way
Indian Island, Maine 04468
(207) 817-7471 (phone)
chris.sockalexis@penobscotnation.org

THPO
Passamaquoddy Tribe of Indians
Indian Township Reservation
P.O. Box 301
Princeton, Maine 04668
(207) 796-2301 (phone)
(207) 796-5256 (fax); soctomah@gmail.com

4. Organizational Websites (Note – Subject to Change):

U.S. Army Corps of Engineers, N.E. District	www.nae.usace.army.mil/missions/regulatory.aspx
U.S. Army Corps of Engineers, Headquarters	See above link>>Useful Links>>Federal Agency Links
U.S. Environmental Protection Agency	www.epa.gov/owow/wetlands
National Marine Fisheries Service	www.nmfs.noaa.gov
U.S. Fish and Wildlife Service	www.fws.gov/mainefieldoffice
National Park Service	www.nps.gov/rivers/index.html
Maine Department of Environmental Protection	www.maine.gov/dep
Maine Department of Agriculture, Conservation and Forestry	www.maine.gov/acf/index.shtml
Maine Land Use Planning Commission	www.maine.gov/doc/lupc/commission/offices.shtml
Maine Department of Marine Resources	www.maine.gov/dmr/index.htm
State of Maine - Aquaculture Guidelines	www.maine.gov/dmr/aquaculture/index.htm

Appendix F: Definitions

Definitions

Attendant Features: Occurring with or as a result of; accompanying.

Biodegradable: A material that decomposes into elements found in nature within a reasonably short period of time and will not leave a residue of plastic or a petroleum derivative in the environment after degradation. Examples of biodegradable materials include jute, sisal, cotton, straw, burlap, coconut husk fiber (coir) or excelsior. In contrast, degradable plastics break down into plastic fragments that remain in the environment after degradation.

Boating facilities: These provide, rent or sell mooring space, such as marinas, yacht clubs, boat yards, dockminiums, town facilities, land/home owners, etc. Not classified as boating facilities are piers shared between two abutting properties or town mooring fields that charge an equitable user fee based on the actual costs incurred.

Brushing the Flats: The placement of tree boughs, wooden lath structure, or small-mesh fencing on mudflats, or any bottom disturbance (e.g., discing, plowing, raking, etc.), to enhance recruitment of shellfish.

Buffer Zone: The buffer zone of an FNP is equal to three times the authorized depth of the FNP.

Construction mats: Constructions, swamp and timber mats (herein referred to as “construction mats”) are generic terms used to describe structures that distribute equipment weight to prevent wetland damage while facilitating passage and providing work platforms for workers and equipment. They are comprised of sheets or mats made from a variety of materials in various sizes. A timber mat consists of large timbers bolted or cabled together. Corduroy roads, which are not considered to be construction mats, are cut trees and/or saplings with the crowns and branches removed, and the trunks lined up next to one another. Corduroy roads are typically installed as permanent structures. Like construction mats, they are considered as fill whether they are installed temporarily or permanently.

Cumulative effects: See “Direct, secondary, and cumulative effects.”

Direct, secondary, and cumulative effects:

Direct Effects: The loss of aquatic ecosystem within the footprint of the discharge of dredged or fill material. Direct effects are caused by the action and occur at the same time and place.

Secondary Effects: These are effects on an aquatic ecosystem that are associated with a discharge of dredged or fill materials, but do not result from the actual placement of the dredged or fill material. Information about secondary effects on aquatic ecosystems shall be considered prior to the time final Section 404 action is taken by permitting authorities. Some examples of secondary effects on an aquatic ecosystem are a) aquatic areas drained, flooded, fragmented, or mechanically cleared, b) fluctuating water levels in all impoundment and downstream associated with the operation of a dam, c) septic tank leaching and surface runoff from residential or commercial developments on fill, and d) leachate and runoff from a sanitary landfill located in waters of the U.S. See 40 CFR 230.11(h).

Cumulative Effects: The changes in an aquatic ecosystem that are attributable to the collective effect of a number of individual 1) discharges of dredged or fill material, or 2) structures. Although the impact of a particular discharge may constitute a minor change in itself, the cumulative effect of numerous such piecemeal changes can result in a major impairment of the water resources and interfere with the productivity and water quality of existing aquatic ecosystems. See 40 CFR 230(g).

Dredging:

Maintenance Dredging: Includes areas and depths previously authorized by the Corps and dredged. The Corps may require proof of authorization. Maintenance dredging typically refers to the routine removal of accumulated sediment from channel beds to maintain the design depths of navigation channels, harbors, marinas, boat launches and port facilities. Routine maintenance dredging is conducted regularly for navigational purposes (typically at least once every ten years) and does not include any expansion of the previously dredged area or depth. The Corps may review a maintenance dredging activity as new dredging if sufficient time has elapsed to allow for the colonization of SAS,

shellfish, etc. The main characteristics of maintenance dredging projects are variable quantities of material; soft, uncompacted soil; contaminant content possible; thin layers of material; occurring in navigation channels and harbors; repetitive activity

New Dredging: Dredging of an area or to a depth that has never been authorized by the Corps or dredged.

Dredged material & discharge of dredged material: These are defined at 323.2(c) and (d). The term dredged material means material that is excavated or dredged from waters of the U.S.

Essential Fish Habitat (EFH): This is broadly defined to include those waters and substrate necessary to fish for spawning, breeding, feeding, or growth to maturity.

Fill material & discharge of fill material: These are defined at 323.2(e) and (f). The term fill material is defined as material placed in waters of the U.S. where the material has the effect of either replacing any portion of a water of the U.S. with dry land or changing the bottom elevation of any portion of a water of the U.S.

Federal anchorages, Federal channels and Federal turning basin: Refer to Appendix H for those in Maine

Federal navigation projects (FNPs): These areas are maintained by the Corps; authorized, constructed and maintained on the premise that they will be accessible and available to all on equal terms; and are comprised of Federal Anchorages, Federal Channels and Federal Turning Basins. The buffer zone is equal to three times the authorized depth of a FNP. More information on the following FNPs is provided at www.nae.usace.army.mil/missions/navigation.aspx >> Navigation Projects.

Flume: An open artificial water channel, in the form of a gravity chute, that leads water from a diversion dam or weir completely aside a natural flow. A flume can be used to measure the rate of flow.

Frac out: During normal drilling operations, drilling fluid travels up the borehole into a pit. When the borehole becomes obstructed or the pressure becomes too great inside the borehole, the ground fractures and fluid escapes to the surface.

Independent utility: A test to determine what constitutes a single and complete non-linear project in the Corps regulatory program. A project is considered to have independent utility if it would be constructed absent the construction of other projects in the project area. Portions of a multi-phase project that depend upon other phases of the project do not have independent utility. Phases of a project that would be constructed even if the other phases were not built can be considered as separate single and complete projects with independent utility.

Individual Permit: A Department of the Army authorization that is issued following a case-by-case evaluation of a specific structure or work in accordance with the procedures of 33 CFR 322, or a specific project involving the proposed discharge(s) in accordance with the procedures of 33 CFR 323, and in accordance with the procedures of 33 CFR 325 and a determination that the proposed discharge is in the public interest pursuant to 33 CFR 320.

Maintenance: Regulations on maintenance are provided at 33 CFR 323.4. The following definitions are applicable:

Minor deviations: Deviations in the structure's configuration or filled area, including those due to changes in materials, construction techniques, or current construction codes or safety standards, which are necessary to make repair, rehabilitation, or replacement are permitted, provided the adverse environmental effects resulting from such repair, rehabilitation, or replacement are minimal.

Currently serviceable: Useable as is or with some maintenance, but not so degraded as to essentially require reconstruction.

Marina reconfiguration zone: A Corps-authorized area in which permittees may rearrange pile-supported structures and floats without additional authorizations. A reconfiguration zone does not grant exclusive privileges to an area or an increase in structure or float area.

Navigable waters of the U.S.: See Waters of the U.S. below.

Overall project: See "single and complete linear project" below.

Practicable: Available and capable of being done after taking into consideration cost, existing technology, and logistics in light of overall project purposes.

Permanent impacts: Permanent impacts means waters of the U.S. that are permanently affected by filling, flooding, excavation, or drainage because of the regulated activity. Permanent impacts include permanent discharges of dredged or fill material that change an aquatic area to dry land, increase the bottom elevation of a waterbody, or change the use of a waterbody. Temporary impacts include waters of the U.S. that are temporarily filled, flooded, excavated, drained or mechanically cleared because of the regulated activity.

Pre-construction notification (PCN): A request submitted by the project proponent to the Corps for confirmation that a particular activity is authorized by this GP. The request may be a permit application, letter, or similar document that includes information about the proposed work and its anticipated environmental effects. Pre-construction notification may be required by the terms and conditions of these GPs. A PCN may be voluntarily submitted in cases where PCN is not required and the project proponent wants confirmation that the activity is authorized under this GP.

Secondary effects: See “Direct, secondary, and cumulative effects.”

Single and complete linear project: A linear project is a project constructed for the purpose of getting people, goods, or services from a point of origin to a terminal point, which often involves multiple crossings of one or more waterbodies at separate and distant locations. The term “single and complete project” is defined as that portion of the total linear project proposed or accomplished by one owner/developer or partnership or other association of owners/developers that includes all crossings of a single water of the U.S. (i.e., a single waterbody) at a specific location. For linear projects crossing a single or multiple waterbodies several times at separate and distant locations, each crossing is considered a single and complete project for the purposes of this GP. However, individual channels in a braided stream or river, or individual arms of a large, irregularly shaped wetland or lake, etc., are not separate waterbodies, and crossings of such features cannot be considered separately.

The overall project, for purposes of this GP, includes all regulated activities that are reasonably related and necessary to accomplish the project purpose.

Single and complete non-linear project: For non-linear projects, the term “single and complete project” is defined at 33 CFR 330.2(i) as the total project proposed or accomplished by one owner/developer or partnership or other association of owners/developers. For non-linear projects, the single and complete project must have independent utility (see definition).

Special aquatic sites: These include inland and saltmarsh wetlands, mud flats, vegetated shallows, sanctuaries and refuges, coral reefs, and riffle and pool complexes. These are defined at 40 CFR 230 Subpart E.

Stream channelization: The manipulation of a stream’s course, condition, capacity, or location that causes more than minimal interruption of normal stream processes. A channelized stream remains a water of the United States.

Temporary impacts: See permanent impacts above.

Utility line: Any pipe or pipeline for the transportation of any gaseous, liquid, liquescent, or slurry substance, for any purpose, and any cable, line, or wire for the transmission for any purpose of electrical energy, telephone, and telegraph messages, and radio and television communication. The term ‘utility line’ does not include activities that drain a water of the U.S., such as drainage tile or French drains, but it does apply to pipes conveying drainage from another area.

Vegetated shallows: Permanently inundated areas that under normal circumstances support communities of rooted aquatic vegetation, such as eelgrass and widgeon grass (*Ruppiamaritima*) in marine systems (doesn’t include salt marsh) as well as a number of freshwater species in rivers and lakes. Note: These areas are also commonly referred to as submerged aquatic vegetation (SAV).

Vernal pools (VPs): For the purposes of this GP, VPs are depressional wetland basins that typically go dry in most years and may contain inlets or outlets, typically of intermittent flow. Vernal pools range in both size and depth depending upon landscape position and parent material(s). Pools usually

support one or more of the following obligate indicator species: wood frog, spotted salamander, blue-spotted salamander, marbled salamander, Jefferson's salamander and fairy shrimp. However, they should preclude sustainable populations of predatory fish.

VP areas are:

- Depression (includes the VP depression up to the spring or fall high water mark, and includes any vegetation growing within the depression),
- Envelope (area within 100 feet of the VP depression's edge), and
- Critical terrestrial habitat (area within 100-750 feet of the VP depression's edge).

Note: See footnote to GC 23. The Corps may determine during the PCN review that a waterbody should not be designated as a VP based on available evidence.

Water diversions: Water diversions are activities such as bypass pumping (e.g., "dam and pump") or water withdrawals. Temporary flume pipes, culverts or cofferdams where normal flows are maintained within the stream boundary's confines aren't water diversions. "Normal flows" are defined as no change in flow from pre-project conditions.

Weir: A barrier across a river designed to alter the flow characteristics. In most cases, weirs take the form of a barrier, smaller than most conventional dams, across a river that causes water to pool behind the structure (not unlike a dam) and allows water to flow over the top. Weirs are commonly used to alter the flow regime of the river, prevent flooding, measure discharge and help render a river navigable.

Waters of the U.S. & Waters of the United States (U.S.): The term waters of the U.S. and all other terms relating to the geographic scope of jurisdiction are defined at 33 CFR 328. Also see Section 502(7) of the Federal CWA [33 USC 1352(7)]. Waters of the U.S. include jurisdictional wetlands. Not all waters and wetlands are jurisdictional. Contact the Corps with any questions regarding jurisdiction.

Navigable waters: Refer to 33 CFR 329. These waters include the following federally designated navigable waters in New England. This list represents only those waterbodies for which affirmative determinations have been made; absence from this list should not be taken as an indication that the waterbody is not navigable:

ME: All tidal waters; Kennebec River to Moosehead Lake; Penobscot River to the confluence of the East and West Branch at Medway, Maine; Lake Umbagog within the State of Maine.

Appendix G: Additional References

1. GC 2: Federal Jurisdictional Boundaries.

(a) Corps Wetlands Delineation Manual, regional supplements, and Corps Wetland Delineation Data Sheets: www.nae.usace.army.mil/missions/regulatory and then “Wetlands and Jurisdictional Limits.”

(b) The USFWS publishes the 1988 National List of Plant Species that Occur in Wetlands (www.nwi.fws.gov).

The Natural Resources Conservation Service (NRCS) publishes the current hydric soil definition, criteria and lists: <http://soils.usda.gov/use/hydric>. For the Field Indicators for Identifying Hydric Soils in N.E., see www.neiwpc.org/hydricsoils.asp.

2. GC 5: Single and Complete Project.

Single and complete project means the total project proposed or accomplished by one owner/developer or partnership or other association of owners/developers. For example, if construction of a residential development affects several different areas of a headwater or isolated water, or several different headwaters or isolated waters, the cumulative total of all filled areas should be the basis for deciding whether or not the project will be covered by Category 1 or 2.

The *Independent utility* test is used to determine what constitutes a single and complete project in the Corps regulatory program. A project is considered to have independent utility if it would be constructed absent the construction of other projects in the project area. Portions of a multi-phase project that depend upon other phases of the project do not have independent utility. Phases of a project that would be constructed even if the other phases were not built can be considered as separate single and complete projects with independent utility.

3. GC 8: Threatened and Endangered Species.

(a) The following NMFS site must be referenced to ensure that listed species or critical habitat are not present in the action area [GC 8(b)] or to provide information on federally-listed species or habitat [GC 8(e)]: www.nero.noaa.gov/prot_res/esp/ListE&Tspec.pdf. Contact the USFWS for information to check for the presence of listed species (see Appendix D for contact information & procedures).

(b) The Endangered Species Act Consultation Handbook – Procedures for Conducting Section 7 Consultations and Conferences, defines action area as “all areas to be affected directly or indirectly by the federal action and not merely the immediate area involved in the action. [50 CFR 402.02].”

4. GC 42: Essential Fish Habitat.

As part of the GP screening process, the Corps may coordinate with NMFS in accordance with the 1996 amendments to the Magnuson-Stevens Fishery Conservation and Management Act to protect and conserve the habitat of marine, estuarine and anadromous finfish, mollusks, and crustaceans. This habitat is termed “Essential Fish Habitat (EFH)”, and is broadly defined to include “those waters and substrate necessary to fish for spawning, breeding, feeding, or growth to maturity.” There are EFH waters throughout inland and coastal waters in Maine. For additional information, see the EFH regulations 50 CFR 600 at www.nero.noaa.gov/hcd including the “Guide for EFH Descriptions” at www.nero.noaa.gov/hcd/list.htm. Additional information on the location of EFH can be obtained from NMFS (see Appendix D for contact information).

5. GC 4: Avoidance, Minimization and Compensatory Mitigation.

(a) See www.nae.usace.army.mil/missions/regulatory and then “Mitigation” to view the April 10, 2008 “Final Compensatory Mitigation Rule” (33 CFR 332) and related documents. The Q&A document states: “In order to reduce risk and uncertainty and help ensure that the required compensation is provided, the rule establishes a preference hierarchy for mitigation options. The most preferred option

is mitigation bank credits, which are usually in place before the activity is permitted. In-lieu fee program credits are second in the preference hierarchy, because they may involve larger, more ecologically valuable compensatory mitigation projects as compared to permittee-responsible mitigation. Permittee-responsible mitigation is the third option, with three possible circumstances: (1) conducted under a watershed approach, (2) on-site and in kind, and (3) off-site/out-of-kind.

(b) Compensatory mitigation may take the form of wetland preservation, restoration, enhancement, creation, and/or in lieu fee (ILF) for inclusion into the Natural Resources Mitigation Fund for projects in DEP and LURC territories. Avoidance of wetland impacts will reduce the ILF dollar total for applicants. The ILF compensation program was established to provide applicants with a flexible compensation option over and above traditional permittee responsible compensation projects. See the Maine ILF Agreement at www.nae.usace.army.mil/missions/regulatory, “Mitigation” and then “Maine,” or www.maine.gov/dep/blwq/docstand/nrpa/ILF_and_NRCP/index.htm.

6. GCs 24, 15, and 43: Invasive Species.

(a) Information on what are considered “invasive species” is provided in our “Compensatory Mitigation Guidance” document at www.nae.usace.army.mil/missions/regulatory under “Mitigation.” The “Invasive Species” section has a reference to our “Invasive Species Control Plan (ISCP) Guidance” document, located at www.nae.usace.army.mil/missions/regulatory under “Invasive Species,” which provides information on preparing an ISCP.

(b) The June 2009 “Corps of Engineers Invasive Species Policy” is at www.nae.usace.army.mil/missions/regulatory under “Invasive Species” and provides policy, goals and objectives.

7. GC 44: Bank Stabilization.

This generally eliminates bodies of water where the reflected wave energy may interfere with or impact on harbors, marinas, or other developed shore areas. A revetment is sloped and is typically employed to absorb the direct impact of waves more effectively than a vertical seawall. It typically has a less adverse effect on the beach in front of it, abutting properties and wildlife. See the Corps Coastal Engineering Manual [EM 1110-2-1100](#) at www.nae.usace.army.mil/missions/regulatory under “Useful Links and Documents” for design and construction guidance.

8. GC 45: Stream and Wetland Crossings.

(a) Projects should be designed and constructed to ensure long-term success using the most recent manual located at www.nae.usace.army.mil/missions/regulatory under “Stream and River Continuity,” currently “Stream Simulation: An Ecological Approach to Providing Passage for Aquatic Organisms at Road-Stream Crossings, by the U.S. Forest Service.” Section 5.3.3 is of particular importance. Sections 7.5.2.3 Construction Methods and 8.2.11 Stream-Simulation Bed Material Placement both show important steps in the project construction.

(b) For more information on High-Quality Stream Segments and their components see:

i. High-Quality Stream Segments are shown at www.maine.gov/dep/gis/datamaps.

ii. Class A Waters or Class AA Waters:

www.mainelegislature.org/legis/statutes/38/title38sec465.html, and

www.mainelegislature.org/legis/statutes/38/title38sec467.html.

iii. Outstanding river segments www.mainelegislature.org/legis/statutes/38/title38sec480-P.html.

(c) The Massachusetts Dam Removal and the Wetland Regulations offer guidance to evaluate the positive and negative impacts of culvert replacement, including the loss of upstream wetlands, which may be offset by the overall benefits of the river restoration. See

www.nae.usace.army.mil/missions/regulatory and then “Stream and River Continuity.”

(d) The ME DOT's document "Waterway and Wildlife Crossing Policy and Design Guide for Aquatic Organism, Wildlife Habitat, and Hydrologic Connectivity," 3rd Edition, July 2008, may be used as guidance to evaluate impacts to aquatic, wildlife and surface water resources when designing, constructing, repairing and maintaining stream crossings. Note: Adherence to this DOT document does not ensure compliance with this GP. Projects must comply with the requirements of this GP including GC 45 and the Corps General Stream Crossing Standards contained therein.

www.maine.gov/mdot/environmental-office-homepage/fishpassage/3rd%20edition%20-%20merged%20final%20version%207-01-08a1.pdf.

(e) GC 45(f): The Skidder Bridge Fact Sheet at www.nae.usace.army.mil/missions/regulatory under "Stream and River Continuity" may be a useful temporary span construction method.

9. GC 45: Wetland Crossings. The Maine DEP's crossing standards are at 06-096 DEP, Chapter 305: Permits by Rule, 9 & 10) Crossings (utility lines, pipes and cables).
www.maine.gov/dep/blwq/rules/NRPA/2009/305/305_effective_2009.pdf

10. GC 23: Protection of Vernal Pools.

(a) The state's Significant Wildlife Habitat rules ([Chapter 335](#), Section 9(C) "Habitat management standards for significant vernal pool habitat") are located at

www.maine.gov/dep/blwq/docstand/nrpapage.htm#rule under "Rules."

(b) The following documents provide conservation recommendations:

i. Best Development Practices: Conserving pool-breeding amphibians in residential and commercial development in the northeastern U.S., Calhoun and Klemens, 2002. Chapter III, Management Goals and Recommendations, Pages 15 – 26, is particularly relevant. (Available for purchase at www.maineaudubon.org/resource/index.shtml and on Corps website*.)

ii. Science and Conservation of Vernal Pools in Northeastern North America, Calhoun and deMaynadier, 2008. Chapter 12, Conservation Recommendations section, Page 241, is particularly relevant. (Available for purchase via the internet. Chapter 12 is available on Corps website*.)

* www.nae.usace.army.mil/reg under "Vernal Pools."

(c) Cape Cod Curbing: For smaller roads and driveways, the most important design feature to consider is curbing. Granite curbs and some traditional curbing can act as a barrier to amphibian and hatchling turtle movements. Large numbers of salamanders have been intercepted in their migrations by curbs and catch basins. Use of Cape Cod curbs rather than traditional curbing may be one solution. Alternatively, where storm water management systems require more traditional curbing, it may be possible to design in escape ramps on either side of each catch basin. Cape Cod curbing is shown on Page 35 of the document cited in 10.b.i above. Bituminous material is not required; other materials such as granite are acceptable.

(d) The VP Directional Buffer Guidance document is located at www.nae.usace.army.mil/missions/regulatory under: 1) "State General Permits" and then "Maine," and 2) "Vernal Pools."

11. GC 29: Maintenance. River restoration projects that are designed to accommodate the natural dynamic tendencies of the fluvial system are maintained in accordance with the project's design objectives (Category 1) or the Corps authorization letter (Category 2). These projects are generally designed to support and implement channel assessment and management practices that recognize a stream's natural dynamic tendencies.

Appendix H: Federal Navigation Projects in Maine

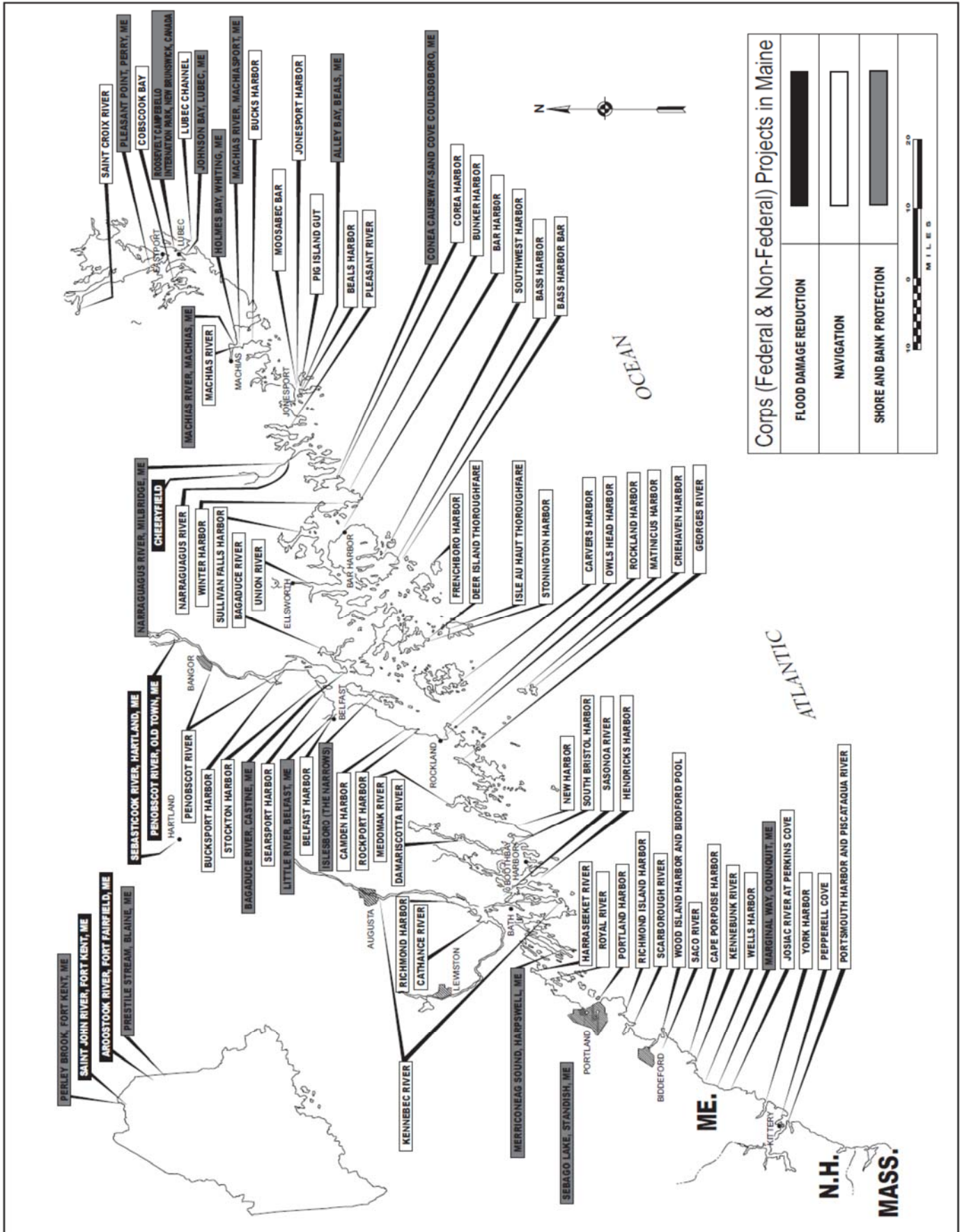

(This page left intentionally blank)

APPENDIX L

TUNNEL PANEL SCHEDULE

(This page left intentionally blank)

York

400 Amp main disconnect in Toll Building

General Information

Panel ID Sub-panel Tunnel DP #2 Booth 1 & 2
 Panel Location Tunnel
 Fed From Toll Building - Line power

Breaker Details

Main Breaker 100 AMP

Phase Type

Three Phase

Voltage Type

120/208

Pole	Amps	Description - Booth #1	Description - Booth #2	Amps	Pole
2	30	Booth #1 Heat Pump	2 Booth #2 Heat Pump	30	2
2	30	Booth #1 Heat Pump	4 Booth #2 Heat Pump	30	2
1	20	Under Counter Heater Fan #1	6 Under Counter Heater Fan #2	20	1
1	20	DP receptacles #1 (Strip)	8 DP receptacles #2 (Strip)	20	1
1	15	Booth #1 lights	10 Booth #2 lights	15	1
1	15	canopy lights #1	12 canopy lights #2	15	1
1	15	Lane use signal #1	14 Lane use signal #2	15	1
1	15	Canopy Sign Lights #1	16 Canopy Sign Lights #2	15	1
1	15	Flashing Yellow Beacon #1	18 Flashing Yellow Beacon #2	15	1
1	20	Canopy Drain De-icing Tape	20 DP receptacles #2 (Quad)	20	1
1	20	DP receptacles #1 (Quad)	22 AVI Reader dirty power	20	1
		Spare	23 24 Spare		
		Spare	25 26 Spare		
		Spare	27 28 Spare		
		Spare	29 30 Spare		

York

400 Amp main disconnect in Toll Building

General Information

Panel ID	Panel Location	Fed From	Breaker Details	Phase Type	Voltage Type
	Sub-panel Tunnel CP #2 Booth, 1,2,3,4 and 5			Three Phase	120/208
	Tunnel				
	UPS / Bypass Switch		Main Breaker 60 AMP		
	Pole				
	1	15	Decription - Booth 1, 2 and 3	1	15
	1	15	Lane Controller - Lane 1	2	15
	1	15	CP Receptacles - Lane 1	3	15
	1	15	DVAS - Lane 1	4	15
	1	15	Lane Controller - Lane 2	5	15
	1	15	CP Receptacles - Lane 2	6	15
	1	15	DVAS - Lane 2	7	15
	1	15	Lane Controller - Lane 3	8	15
	1	15	CP Receptacles - Lane 3	9	15
	1	15	DVAS - Lane 3	10	15
	1	15	Lane Controller - Lane 4	11	15
	1	15	CP Receptacles - Lane 4	12	15
	1	15	DVAS - Lane 4	13	15
	1	15	Lane Controller - Lane 5	14	15
	1	15	CP Receptacles - Lane 5	15	15
	1	15	DVAS - Lane 5	16	15
	1	15	Lane Controller - Lane 6	17	20
	1	15	CP Receptacles - Lane 6	18	20
	1	15	DVAS - Lane 6	19	20
	1	15	Lane Controller - Lane 7	20	20
	1	15	CP Receptacles - Lane 7	21	20
	1	15	DVAS - Lane 7	22	20
	1	15	Lane Controller - Lane 8	23	20
	1	15	CP Receptacles - Lane 8	24	20
	1	15	DVAS - Lane 8	25	20
	1	15	Lane Controller - Lane 9	26	20
	1	15	CP Receptacles - Lane 9	27	20
	1	15	DVAS - Lane 9	28	20
	1	15	Lane Controller - Lane 10	29	20
	1	15	CP Receptacles - Lane 10	30	20
	1	15	DVAS - Lane 10		20

York
400 Amp main disconnect in Toll Building

General Information

Panel ID Sub-panel Tunnel DP #3 Booth 3 & 4
 Panel Location Tunnel
 Fed From Toll Building - Line power

Breaker Details

Main Breaker 100 AMP

Phase Type

Three Phase

Voltage Type

120/208

Pole	Amps	Description - Booth #3	Description - Booth #4	Amps	Pole
2	30	Booth #3 Heat Pump	2 Booth #4 Heat Pump	30	2
2	30	Booth #3 Heat Pump	4 Booth #4 Heat Pump	30	2
1	20	Under Counter Heater Fan #3	6 Under Counter Heater Fan #4	20	1
1	20	DP receptacles #3 (Strip)	8 DP receptacles #4 (Strip)	20	1
1	15	Booth #3 lights	10 Booth #4 lights	15	1
1	15	canopy lights #3	12 canopy lights #4	15	1
1	15	Lane use signal #3	14 Lane use signal #4	15	1
1	15	Canopy Sign Lights #3	16 Canopy Sign Lights #4	15	1
1	15	Flashing Yellow Beacon #3	18 Flashing Yellow Beacon #4	15	1
1	20	Canopy Drain De-icing Tape	20 DP receptacles #4 (Quad)	20	1
	20	DP receptacles #3 (Quad)	22 AVI Reader dirty power	20	
		Spare	24 Spare		
		Spare	26 Spare		
		Spare	28 Spare		
		Spare	30 Spare		

York
400 Amp main disconnect in Toll Building

General Information

Panel ID Sub-panel Tunnel DP-#4 ORT & Lane 5
 Panel Location Tunnel
 Fed From Toll Building - Line power

Breaker Details

Main Breaker 60 AMP

Phase Type

Three Phase

Voltage Type

120/208

Pole	Amps	Description	Description	Amps	Pole
1	15	NB ORT Space Frame Lights 1	2 SB ORT Space Frame Lights 1	15	1
1	15	NB ORT Space Frame Lights 2	3 NB ORT Space Frame Lights 2	15	1
1	15	NB ORT Variable SL Sign	5 NB ORT Variable SL Sign	15	1
1	20	NB ORT Reader #1 Dirty Power	7 NB ORT Reader #1 Dirty Power	20	1
1	20	NB ORT Reader #2 Dirty Power	9 NB ORT Reader #2 Dirty Power	20	1
2	30	Booth #5 Heat Pump	11 Booth #5 Heat Pump	15	1
2	30	Booth #5 Heat Pump	13 Booth #5 Heat Pump	15	1
1	20	Under Counter Heater Fan #5	15 Under Counter Heater Fan #5	15	1
1	20	DP receptacles #5 (Strip)	17 DP receptacles #5 (Quad)	20	1
1	15	Booth #5 lights	19 Booth #5 lights	15	1
		Spare	21 Spare		
		Spare	23 Spare		
		Spare	25 Spare		
		Spare	27 Spare		
		Spare	29 Spare		

York

400 Amp main disconnect in Toll Building

General Information

Breaker Details

Phase Type

Voltage Type

Panel ID

Panel Location

Fed From

Sub-panel Tunnel CP#3 ORT

Tunnel

UPS / Bypass Switch

Three Phase

120/208

Main Breaker 60 AMP

Pole	Amps	Description - NB	Description	Amps	Pole
1	15	NB OPUS	2 SB OPUS	15	1
1	15	NB VCARS Lane - NB1	4 SB VCARS Lane - SB1	15	1
1	15	NB VCARS Lane - NB2	6 SB VCARS Lane - SB2	15	1
1	15	NB VCARS Lane - NB3	8 SB VCARS Lane - SB3	15	1
1	15	NB VCARS Lane - NB4	10 SB VCARS Lane - SB4	15	1
1	15	NB VCARS Lane - NB5	12 SB VCARS Lane - SB5	15	1
1	15	NB DVAS Lane - NB1	14 SB DVAS Lane - SB1	15	1
1	15	NB DVAS Lane - NB1	16 SB DVAS Lane - SB1	15	1
1	20	NB Clean Power AVI Reader #1	18 SB Clean Power AVI Reader #1	20	1
1	20	NB Clean Power AVI Reader #2	20 SB Clean Power AVI Reader #2	20	1
1	20	NB Clean Power Lane Controller	22 SB Clean Power Lane Controller	20	1
		Spare	24 Spare		
		Spare	26 Spare		
		Spare	28 Spare		
		Spare	30 Spare		

York
400 Amp main disconnect in Toll Building

General Information

Panel ID Sub-panel Tunnel DP #5 Booth 6 & 7
 Panel Location Tunnel
 Fed From Toll Building - Line power

Breaker Details

Main Breaker 100 AMP

Phase Type

Three Phase

Voltage Type

120/208

Pole	Amps	Description - Booth #6	Description - Booth #7	Amps	Pole
2	30	Booth #6 Heat Pump	2 Booth #7 Heat Pump	30	2
2	30	Booth #6 Heat Pump	4 Booth #7 Heat Pump	30	2
1	20	Under Counter Heater Fan #6	6 Under Counter Heater Fan #7	20	1
1	20	DP receptacles #6 (Strip)	8 DP receptacles #7 (Strip)	20	1
1	15	Booth #6 lights	10 Booth #7 lights	15	1
1	15	canopy lights #6	12 canopy lights #7	15	1
1	15	Lane use signal #6	14 Lane use signal #7	15	1
1	15	Canopy Sign Lights #6	16 Lane Use Sign (VMS)	15	1
1	15	Flashing Yellow Beacon #6	18 Flashing Yellow Beacon #7	15	1
1	20	Canopy Drain De-icing Tape	20 DP receptacles #7 (Quad)	20	1
1	20	DP receptacles #6 (Quad)	22 AVI Reader dirty power	20	1
		Spare	24 Spare		
		Spare	26 Spare		
		Spare	28 Spare		
		Spare	30 Spare		

York

400 Amp main disconnect in Toll Building

General Information

Panel ID
Panel Location
Fed From

Sub-panel Tunnel CP #4 Booth 6,7,8 and 9
Tunnel
UPS / Bypass Switch

Breaker Details

Main Breaker 60 AMP

Phase Type

Three Phase

Voltage Type

120/208

Pole	Amps	Description - Booth - 6 and 7	Description - Booth - 8 and 9	Amps	Pole
1	15	Lane Controller - Lane 6	2 Lane Controller - Lane 8	15	1
1	15	CP Receptacles - Lane 6	4 CP Receptacles - Lane 8	15	1
1	15	DVAS - Lane 6	6 DVAS - Lane 8	15	1
1	15	Lane Controller - Lane 7	8 Lane Controller - Lane 9	15	1
1	15	CP Receptacles - Lane 7	10 CP Receptacles - Lane 9	15	1
1	15	DVAS - Lane 7	12 DVAS - Lane 9	15	1
		Spare	14 Clean Power AVI Reader	20	1
		Spare	16 Spare		
		Spare	18 Spare		
		Spare	20 Spare		
		Spare	22 Spare		
		Spare	24 Spare		
		Spare	26 Spare		
		Spare	28 Spare		
		Spare	30 Spare		

York
400 Amp main disconnect in Toll Building

General Information

Panel ID Sub-panel Tunnel DP #6 Booth 8 & 9
 Panel Location Tunnel
 Fed From Toll Building - Line power

Breaker Details

Main Breaker 100 AMP

Phase Type Voltage Type

Three Phase 120/208

Pole	Amps	Description - Booth #8	Description - Booth #9	Amps	Pole
2	30	Booth #8 Heat Pump	2 Booth #9 Heat Pump	30	2
2	30	Booth #8 Heat Pump	4 Booth #9 Heat Pump	30	2
1	20	Under Counter Heater Fan #8	6 Under Counter Heater Fan #9	20	1
1	20	DP receptacles #8 (Strip)	8 DP receptacles #9 (Strip)	20	1
1	15	Booth #8 lights	10 Booth #9 lights	15	1
1	15	canopy lights #8	12 canopy lights #9	15	1
1	15	Canopy Sign Lights #8	14 Lane use signal #9	15	1
1	15	Flashing Yellow Beacon #8	16 Lane Use Sign (VMS)	15	1
1	20	Canopy Drain De-icing Tape	18 Flashing Yellow Beacon #9	15	1
1	20	DP receptacles #8 (Quad)	20 DP receptacles #9 (Quad)	20	1
		Spare	21 22 Spare		
		Spare	23 24 Spare		
		Spare	25 26 Spare		
		Spare	27 28 Spare		
		Spare	29 30 Spare		