

MAINE TURNPIKE AUTHORITY

NOTICE TO CONTRACTORS

Sealed Proposals will be received by the Maine Turnpike Authority for:

CONTRACT 2019.12

NEW MECHANICS GARAGE
LITCHFIELD MAINTENANCE FACILITY
MILE MARKER 92.7

at the office of the Maine Turnpike Authority, 2360 Congress Street, Portland, ME, until 1:00 p.m., prevailing time as determined by the Authority on November 14, 2019 at which time and place the Proposals will be publicly opened and read. Bids will be accepted from Contractors prequalified by the Maine Department of Transportation for Building Construction Projects. All other bids may be rejected.

Contractors not currently prequalified by MaineDOT for Building projects can seek prequalification for this project prior to the award by submitting the prequalification application included with this notice directly to the Authority at the above address. Contractors not currently prequalified by MaineDOT for Building Projects or Contractors not prequalified by the MTA for Building projects may not be awarded a contract for this project.

This Project includes a wage determination developed by the State of Maine Department of Labor.

The work consists of the following:

1. Construction of an approximate 10,400 square foot pre-engineered building consisting of a 4-bay equipment maintenance garage, 1 drive-thru wash bay, and a 1,975 SF mezzanine.
2. All site work, grading, drainage, paving, septic field, underground power, power utility services and site utilities.

The work includes all building structure, mechanical, electrical, and plumbing, as well as all site work, grading, pavement, lighting, utilities, and all other work incidental thereto in accordance with the Plans and Specifications.

Plans and Contract Documents may be examined by prospective Bidders weekdays between 8:00 a.m. and 4:30 p.m. at the office of the Maine Turnpike Authority, 2360 Congress St., Portland, ME 04102. The Plans and Contract Documents may be obtained on or after October 15, 2019 from the Authority upon payment of One Hundred Fifty (\$150.00) Dollars for each set, which payment will not be returned. Checks shall be made payable to: Maine Turnpike Authority.

For general information regarding Bidding and Contracting procedures, contact Nathan Carll, Purchasing Manager, at ~~(207) 482-8115~~ **207-871-7739**. **For information regarding Schedule of Items, plan holders list and bid results, visit our website at <http://www.maineturnpike.com/project-and-planning/Construction-Contracts.aspx>** . For project specific information, fax all questions to contact Nathan Carll, Purchasing Manager, at (207) 482-8115. Responses will not be prepared for questions received by

ADDENDUM #1: November 1, 2019

FROM: Allied Engineering, Inc.
160 Veranda Street
Portland, Maine 04103
Telephone: (207) 221-2260

TO: Prospective Bidders, Suppliers, and Other Parties

RE: Addendum No. **1 (One)** to the Bidding Documents for:
NEW MECHANICS GARAGE LITCHFIELD MAINTENANCE FACILITY MILE
MARKER 92.7

This Addendum forms a part of the Contract Documents and modifies the original Bidding Documents dated October 15, 2019. Acknowledge receipt of this Addendum in the space provided on the Proposal Form. Failure to do so may subject Bidder to disqualification.

GENERAL:

1. Questions will be accepted until 12:00 PM on November 7, 2019.

PROPOSAL:

1. **DELETE** Proposal Sheet N-1 in its entirety. **ADD** in its Proposal Sheet N-1 (Revised 11/1/19). Footer modified to reflect pagination and correct fax number for Nathan Carll was provided.
2. **DELETE** Proposal Sheet P-1 thru P-8 in their entirety. **ADD** in its Proposal Sheets P-1 thru P-8 (Revised 11/1/19). Footer modified to reflect pagination.
3. **DELETE** Proposal Sheet C-1 thru C-2 in their entirety. **ADD** in its Proposal Sheets C-1 thru C-2 (Revised 11/1/19). Footer modified to reflect pagination.
4. **DELETE** Proposal Sheet CB-1 thru CB-2 in their entirety. **ADD** in its Proposal Sheets CB-1 thru CB-2 (Revised 11/1/19). Footer modified to reflect pagination.
5. **DELETE** Proposal Sheet F-1 thru F-2 in their entirety. **ADD** in its Proposal Sheets F-1 thru F-2 (Revised 11/1/19). Footer modified to reflect pagination.

PLANS

1. DRAWING C-101 SITE AND UTILITY PLAN: **DELETE** in its entirety and **ADD** in its place the revised sheets attached to this addendum. Drawing C-101 has been updated relocating the 6,000-gallon holding tank plan south of the initial location.
2. DRAWING A-4 ROOF PLAN AND DETAILS: **DELETE** in its entirety and **ADD** in its place the revised sheets attached to this addendum. Roof penetrations representation.
3. DRAWING PL-100 SANITARY PIPING PLAN: Refer to sketches SKP-01, 02, & 03 for revised floor drain waste and rainwater piping. South side wash bay catch basin piped as an oil & grit separator.

4. DRAWING E-000 ELECTRICAL ABBREVIATIONS AND LEGENDS: **DELETE** in its entirety and **ADD** in its place the revised drawing attached to this addendum. Changes are as follows: Detail D7: Revised card reader and door lock symbol/descriptions as indicated.
5. DRAWING EL-100 LIGHTING PLAN: **DELETE** in its entirety and **ADD** in its place the revised drawing attached to this addendum. Changes are as follows: Detail E8: Delete key notes that are not used on plans.
6. DRAWING EP-100 POWER AND SYSTEMS PLAN: **DELETE** in its entirety and **ADD** in its place the revised drawing attached to this addendum. Changes are as follows: Add card readers, revises 2 card readers, and add smoke detector.
7. DRAWING EP-600 ELECTRICAL SCHEDULES: **DELETE** in its entirety and **ADD** in its place the revised sheets attached to this addendum. Changes are as follows: Revised Panel P1 and the MDP schedules as indicated.

SPECIFICATIONS

1. Section 012100 – Allowances: **ADD** in its entirety. Allowance value referenced herein shall be include in the value presented for Division 800 – Litchfield Maintenance Garage (SP-49).
2. Section 077200 – Roof Accessories: **ADD** in its entirety.
3. Section 083323 – Overhead Coiling Doors: **ADD** in its entirety.
4. Section 133419 – Metal Building Systems: **DELETE** Section 1.9.B in its entirety.
5. Section 262726 Wiring Devices: **ADD** the following paragraph:
 - 2.11 CORD REELS shall be heavy duty yellow cord retractable with minimum 25’ cord. Provide ratings as indicated. KH industries heavy duty industrial or approved equal. Secure to structure to prevent movement while in use. RT series or approved equal with white housing. Provide cord lengths as required to allow the plugs to be suspended 48” AFF.
6. Section 263213 - Gaseous Emergency Equipment: **REISSUED** in its entirety

CONTRACTOR QUESTIONS/RESPONSES

1. See Attached Question & Response Table

ATTACHMENTS

A. Addendum Summary Document	(2 Pages)
B. Proposal Sheets	(16 Pages)
C. Plan Sheets and Sketches	(9 Pages)
D. Specifications	(35 Pages)
E. Questions/Response Table	(1 Page)
F. Pre-bid Sign in Sheet	<u>(1 Page)</u>
Total Page Count	<u>64 Pages</u>

telephone. Bidders shall not contact any other Authority staff or Consultants for clarification of Contract provisions, and the Authority will not be responsible for any interpretations so obtained.

All work shall be governed by the Specifications entitled "State of Maine, Department of Transportation, Standard Specifications, Revision of November 2014", "Standard Details, Revision of November 2014" and "Best Management Practices for Erosion and Sediment Control", latest issue. Copies and recent updates to these publications can be downloaded at: <http://www.maine.gov/mdot/contractors/publications/>

Proposals must be accompanied by an original bid bond, certified or cashier's check payable to the Maine Turnpike Authority in an amount not less than Five (5%) Percent of the Total Amount in the Proposal, but not less than \$500.00. The Bidder to whom a Contract is awarded will be required to furnish a Surety Corporation Bond, satisfactory to the Authority, on the standard Contract Bond form of the Authority, for a sum not less than the Total Amount of the Proposal.

Proposals must be made upon the Proposal Forms furnished by the Authority separately with the Contract Documents, and must be enclosed in the sealed special addressed envelope provided therefore bearing the name and address of the Bidder, the name of the Contract, and the date and time of Proposal opening on the outside.

A pre-bid meeting will be held on October 22, 2019 at 10:00 a.m. at the office of the Maine Turnpike Authority, 2360 Congress St., Portland, ME. This pre-bid meeting is not required, but it is recommended.

The Authority reserves the unqualified right to reject any or all Proposals and to accept that Proposal which in its sole judgment will under all circumstances serves its best interest.

Very truly yours,

MAINE TURNPIKE AUTHORITY

Nathan Carll
Purchasing Manager
Maine Turnpike Authority,
Portland, Maine

MAINE TURNPIKE AUTHORITY

PROPOSAL

CONTRACT 2019.12

NEW MECHANICS GARAGE
LITCHFIELD MAINTENANCE FACILITY
MILE MARKER 92.7

TO MAINE TURNPIKE AUTHORITY:

The work consists of the following:

1. Construction of an approximate 10,400 square foot pre-engineered building consisting of a 4-bay equipment maintenance garage, 1 drive-thru wash bay, and a 1,975 SF mezzanine.
2. All site work, grading, drainage, septic field, underground power, power utility services and site utilities.

The work includes all building structure, mechanical, electrical, fire protection and plumbing, as well as all site work, grading, pavement, lighting, utilities, and all other work incidental thereto in accordance with the Plans and Specifications.

This Work will be done under a Contract known as Contract 2019.12 according to the Plans and Specifications which are on file in the office of the Maine Turnpike Authority, 2360 Congress Street, Portland, Maine.

On the acceptance of this Proposal for said Work, the undersigned will give the required bond with good security conditioned for the faithful performance of said Work, according to said Plans and Specifications, and the doing of all other work required by said Specifications for the consideration herein named and with the further condition that the Maine Turnpike Authority shall be saved harmless from any and all damages that might accrue to any person, persons or property by reason of the carrying out of said Work, or any part thereof, or by reason of negligence of the undersigned, or any person or persons under his employment and engaged in said Work.

The undersigned hereby declares that he/she has carefully examined the Plans, Specifications and other Contract Documents, and that he/she will contract to carry out and complete the said Work as specified and delineated at the price per unit of measure for each scheduled item of Work stated in the Schedule of Prices as follows:

It is understood that the TOTAL AMOUNT stated by the undersigned in the following Schedule of Prices is based on approximate quantities and will be used solely for the comparison of bids, and that the quantities stated in the Schedule of Prices for the various items are estimates only and may be increased or decreased all as provided in the Specifications.

Item No	Item Description	Units	Approx. Quantities	Unit Prices in Numbers		Bid Amount in Numbers	
203.20	COMMON EXCAVATION	Cubic Yard	2,000				
203.24	COMMON BORROW	Cubic Yard	400				
203.25	GRANULAR BORROW	Cubic Yard	1,300				
304.10	AGGREGATE SUBBASE COURSE - GRAVEL	Cubic Yard	2,050				
304.105	STRUCTURAL FILL	Cubic Yard	400				
403.207	HOT MIX ASPHALT, 19 MM	Ton	375				
403.208	HOT MIX ASPHALT, 12.5 MM	Ton	300				
409.15	BITUMINOUS TACK COAT, APPLIED	Gallon	250				
419.05	SAWING BITUMINOUS PAVEMENT	Linear Foot	550				
603.04	6" PVC DRAIN SERVICE	Linear Foot	40				
603.05	6" PVC PIPE – ROOF DRAIN OUTLET	Linear Foot	40				
603.06	10 INCH CORRUGATED PLASTIC PIPE - OPT III	Linear Foot	10				
603.132	8" CULVERT PIPE OPT III – ROOF DRAIN OUTLET	Linear Foot	40				
604.154	72" MANHOLE	EACH	1				

Item No	Item Description	Units	Approx. Quantities	Unit Prices in Numbers		Bid Amount in Numbers	
BROUGHT FORWARD:							
604.158	UTILITY VAULT (6,000 GALLON HOLDING TANK)	Each	1				
610.08	PLAIN RIPRAP	Cubic Yard	5				
613.319	EROSION CONTROL BLANKET	Square Yard	400				
615.07	LOAM	Cubic Yard	80				
618.14	SEEDING METHOD NUMBER 2	Unit	5				
619.1201	MULCH - PLAN QUANTITY	Unit	5				
633.03	PROPANE SERVICE TRENCH	Linear Foot	105				
655.102	500 KCMIL WIRE	Linear Foot	550				
655.104	#8 AWG WIRE	Linear Foot	900				
655.106	#6 AWG WIRE	Linear Foot	120				
655.11	#10 AWG WIRE	Linear Foot	200				
655.12	#12 AWG WIRE	Linear Foot	680				
655.16	FIBER OPTIC CABLE	Linear Feet	900				
655.2001	1 1/2" SCHEDULE 80 PVC CONDUIT	Linear Foot	120				

Item No	Item Description	Units	Approx. Quantities	Unit Prices in Numbers		Bid Amount in Numbers	
BROUGHT FORWARD:							
655.2002	1" SCHEDULE 80 PVC CONDUIT	Linear Foot	400				
655.2003	2" SCHEDULE 80 PVC CONDUIT	Linear Foot	50				
655.201	3" SCHEDULE 80 PVC CONDUIT	Linear Foot	1000				
655.202	4" SCHEDULE 80 PVC CONDUIT	Linear Foot	500				
655.209	4" GALVANIZED RIGID METAL CONDUIT	Linear Foot	1				
655.2100	1 " LIQUID TIGHT METALLIC FLEXIBLE CONDUIT	Linear Foot	30				
655.2101	1 1/2" LIQUID TIGHT METALLIC FLEXIBLE CONDUIT	Linear Foot	30				
655.2102	2" LIQUID TIGHT METALLIC FLEXIBLE CONDUIT	Linear Foot	30				
655.31	UNDERGROUND PULL BOX	Each	2				
655.40	12" X 12" X 6" NEMA 3R JUNCTION BOX	Each	20				
655.50	2" PVC CONDUIT CONDULETS	Each	5				
655.51	4" PVC CONDUIT CONDULETS	Each	12				

Item No	Item Description	Units	Approx. Quantities	Unit Prices in Numbers		Bid Amount in Numbers	
BROUGHT FORWARD:							
655.52	1" PVC CONDUIT CONDULETS	Each	20				
655.53	1½" PVC CONDUIT CONDULETS	Each	50				
655.55	3" PVC CONDUIT CONDULETS	Each	90				
655.75	CONCRETE ENCASED CONDUIT	Cubic Yard	500				
656.632	30" TEMPORARY SILT FENCE	Linear Foot	700				
659.10	MOBILIZATION	Lump Sum	1				
800.01	LITCHFIELD MAINTENANCE GARAGE	Lump Sum	1				
800.090	CONCRETE GENERATOR PAD	Lump Sum	1				
800.091	CONCRETE WASTE OIL TANK PAD	Lump Sum	1				
801.132	2" FORCE MAIN	Linear Foot	25				
801.16	6" PVC SANITARY SEWER (SDR-35)	Linear Foot	30				
802.23	SEWAGE DISPOSAL SYSTEM	LUMP SUM	1				

Item No	Item Description	Units	Approx. Quantities	Unit Prices in Numbers		Bid Amount in Numbers	
BROUGHT FORWARD:							
802.241	1000 GALLON SEPTIC TANK WITH LIFT STATION	Each	1				
822.3213	2" COPPER SERVICE	Linear Foot	850				
825.343	SPECIAL WATER SERVICE FACILITY (5000 GALLON WATER TANK)	Lump Sum	1				
832.41	TYPE A STEEL SITE BOLLARD	Each	4				
TOTAL:							

Acknowledgment is hereby made of the following Addenda received since issuance of the Plans and Specifications:

Accompanying this Proposal is an original bid bond, cashiers or certified check on _____
_____ Bank, for _____

, payable to the Maine Turnpike Authority. In case this Proposal shall be accepted by the Maine Turnpike Authority and the undersigned should fail to execute a Contract with, and furnish the security required by the Maine Turnpike Authority as set forth in the Specifications, within the time fixed therein, an amount of money equal to Five (5%) Percent of the Total Amount of the Proposal for the Contract awarded to the undersigned, but not less than \$500.00, obtained out of the original bid bond, cashier's or certified check, shall become the property of the Maine Turnpike Authority; otherwise the check will be returned to the undersigned.

The performance of said Work under this Contract will be completed during the time specified in Subsection 107.1.

It is agreed that time is of the essence of this Contract and that I (we) will, in the event of my (our) failure to complete the Work within the time limit named above, pay to Maine Turnpike Authority liquidated damages in the amount or amounts stated in the Specifications.

The undersigned is an Individual/Partnership/Corporation under the laws of the State of _____,
having principal office at _____,
thereunto duly authorized.

_____ (SEAL)

_____ (SEAL)

_____ (SEAL)

Affix Corporate Seal or Power of Attorney
Where Applicable

By: _____

Its: _____

Information below to be typed or printed where applicable:

INDIVIDUAL:

(Name)

(Address)

PARTNERSHIP - Name and Address of General Partners:

(Name)

(Address)

(Name)

(Address)

(Name)

(Address)

(Name)

(Address)

INCORPORATED COMPANY:

(President)

(Address)

(Vice-President)

(Address)

(Secretary)

(Address)

(Treasurer)

(Address)

MAINE TURNPIKE AUTHORITY

CONTRACT AGREEMENT

CONTRACT 2019.12

NEW MECHANICS GARAGE
LITCHFIELD MAINTENANCE FACILITY
MILE MARKER 92.7

This Agreement made and entered into between the Maine Turnpike Authority, and sometimes termed the “Authority”, and _____

_____ herein termed the “Contractor”:

WITNESSETH: That the Authority and the Contractor, in consideration of the premises and of the mutual covenants, considerations and agreements herein contained, agree as follows:

FIRST: The parties hereto mutually agree that the documents attached hereto and herein incorporated and made a part hereof collectively evidencing and constituting the entire Contract to the same extent as if herein written in full, are the Notice to Contractors, the Accepted Proposal, the Specifications, the Plans, this Agreement, the Contract Bond and all Addenda to the Contract Documents duly issued and herewith enumerated:

SECOND: The Contractor for and in consideration of certain payments to be made as hereafter specified, hereby covenants and agrees to perform and execute all of the provisions of this Contract and of all documents and parts attached hereto and made a part thereof, and at his own cost and expense to furnish and perform everything necessary and required to construct and complete, ready for its intended purpose, in accordance with the Contract and such instructions as the Engineer may give, acceptable to the Authority, in the times provided, all of the Work covered and included under Contract No. _____ covering _____ as herein described.

THIRD: In consideration of the performance by the Contractor of his covenants and agreements as herein set forth, the Authority hereby covenants and agrees to pay the Contractor according to the Schedule of Prices set forth in the Proposal with additions and deductions as elsewhere herein provided in the times and in the manner stated in the Specifications. This Agreement shall insure to the benefit of, and shall be binding upon the parties hereto, and upon their respective successors and assigns; but neither party hereto shall assign or transfer his interest herein in whole or in part without the consent of the other, except as herein provided.

IN WITNESS WHEREOF the parties to this Agreement have executed the same in quintuplicate.

AUTHORITY -

MAINE TURNPIKE AUTHORITY

By: _____

Title: CHAIRMAN

Date of Signature: _____

ATTEST:

Secretary

CONTRACTOR -

CONTRACTOR

By: _____

Date of Signature: _____

WITNESS:

MAINE TURNPIKE AUTHORITY

CONTRACT BOND

CONTRACT 2019.12

NEW MECHANICS GARAGE
LITCHFIELD MAINTENANCE FACILITY
MILE MARKER 92.7

KNOW ALL MEN BY THESE PRESENTS that _____
of _____ in the County of _____ and State of _____

_____ as Principal, and _____ a Corporation duly organized under the laws of the State of _____ and having a usual place of business in _____

As Surety, are held and firmly bound unto the Maine Turnpike Authority in the sum of _____ Dollars (\$_____.__), to be paid to said Maine Turnpike Authority, or its successors, for which payment, well and truly to be made, we bind ourselves, our heirs, executors, successors and assigns jointly and severally by these presents.

The condition of this obligation is such that the Principal, designated as Contractor in the foregoing Contract No. _____ shall faithfully perform the Contract on his part and satisfy all claims and demands incurred for the same and shall pay all bills for labor, material, equipment and all other items contracted for, or used by him, in connection with the Work contemplated by said Contract, and shall fully reimburse the Obligee for all outlay and expense which the Obligee may incur in making good any default of said Principal, then this Obligation shall be null and void; otherwise it shall remain in full force and effect.

Signed and sealed this _____ day of _____, A.D., 201 _____

Witnesses:

CONTRACTOR

_____ (SEAL)

_____ (SEAL)

_____ (SEAL)

SURETY

_____ (SEAL)

_____ (SEAL)

_____ (SEAL)

(Surety must attach copy of Power of Attorney showing authority of Office or Agent to execute bonds)

MAINE TURNPIKE AUTHORITY

FINAL LIEN AND CLAIM WAIVER AND AFFIDAVIT

CONTRACT 2019.12

NEW MECHANICS GARAGE
LITCHFIELD MAINTENANCE FACILITY
MILE MARKER 92.7

Upon receipt of the sum of _____, which sum represents the total amount paid, including the current payment for work done and materials supplied for Project No. _____, in _____, Maine, under the undersigned's Contract with the Maine Turnpike Authority.

The undersigned, on oath, states that the Final Payment of _____ is the final payment for all work, labor, materials, services and miscellaneous (all of which are hereinafter referred to as "Work Items") supplied to the said Project through _____ and that no additional sum is claimed by the undersigned respecting said Project.

The undersigned, on oath, states that all persons and firms who supplied Work Items to the undersigned in connection with said Project have been fully paid by the undersigned for such Work Items or that such payment will be fully effected immediately upon receipt of this payment.

In consideration of the payment herewith made, the undersigned does fully and finally release and hold harmless the Maine Turnpike Authority, and its Surety, if any, from any and all claims, liens or right to claim or lien, arising out of this Project under any applicable bond, law or statute.

It is understood that this Affidavit is submitted to assure the Owner and others that all liens and claims relating to the Work Items furnished by the undersigned are paid.

(Contractor)

By: _____

Title: _____

State of MAINE

County of _____

I, _____, hereby certify on behalf of _____
(Company Officer) *(Company Name)*
its _____, being first duly sworn and stated that the foregoing representations are
(Title)

are true and correct upon his own knowledge and that the foregoing is his free act and deed in said capacity
and the free act and deed of the above-
named _____
(Company Name)

The above-named, _____, personally appeared before me this ____ day of
_____ and swears that this is his free act and deed.

(SEAL)

Notary Public _____

My Commission Expires: _____

NOTES:

1. SURVEY AND TOPOGRAPHY PROVIDED BY TITCOMB ASSOCIATES OF FALMOUTH, MAINE, DATED MARCH 1, 2019.
2. ALL DIVISION 2 SITE WORK SHALL BE DONE IN ACCORDANCE WITH THE MAINE DEPARTMENT OF TRANSPORTATION STANDARD SPECIFICATIONS, HIGHWAYS AND BRIDGES, (2014 EDITION) AND AS MODIFIED BY MAINE TURNPIKE 2016 SUPPLEMENTAL SPECIFICATIONS. SPECIAL PROVISIONS HAVE BEEN PREPARED FOR WORK ITEMS NOT ADDRESSED IN THE STANDARD SPECIFICATIONS, AND ARE ENCLOSED AS PART OF THIS CONTRACT. IN THE EVENT OF A CONFLICT BETWEEN THE STANDARD SPECIFICATIONS AND THE SUPPLEMENTAL SPECIFICATIONS, THE MORE STRINGENT STANDARD SHALL APPLY.
3. CONTRACTOR SHALL BE RESPONSIBLE FOR REMOVAL OF ALL SPOIL/EXCESS MATERIAL FROM THE SITE IN ACCORDANCE WITH LOCAL, STATE, AND FEDERAL LAWS.
4. ALL AREAS OUTSIDE THE LIMIT OF WORK DISTURBED BY THE CONTRACTOR SHALL BE RESTORED TO PRIOR CONDITIONS AT NO EXPENSE TO THE OWNER.
5. ALL DISTURBED AREAS INSIDE THE LIMIT OF WORK LINE NOT PROPOSED TO BE IMPROVED SHALL BE RESTORED TO THEIR PRIOR CONDITION, EITHER PAVEMENT, RECYCLED ASPHALT PAVEMENT, OR 4" LOAM AND SEED.
6. CONTRACTOR SHALL COORDINATE WITH SURVEYOR FOR BUILDING/COORDINATE LAYOUT PRIOR TO CONSTRUCTION.
7. ALL PAVEMENT SHALL BE SAWCUT PRIOR TO REMOVAL.
8. A TACK COAT OF EMULSIFIED ASPHALT, RS-1 OR HFMS-1 SHALL BE APPLIED TO ANY EXISTING PAVEMENT AT A RATE OF APPROXIMATELY 0.06 GALLONS/SY. A FOG COAT OF EMULSIFIED ASPHALT SHALL BE BETWEEN SHIM/INTERMEDIATE COURSE AND THE SURFACE COURSE AT A RATE NOT TO EXCEED 0.06 GALLONS/SY.
9. ALL ABOVE GROUND FEATURES AND BELOW GROUND OBSTRUCTIONS, (UTILITIES, FOUNDATIONS, ETC.) ENCOUNTERED DURING EXCAVATION SHALL BE REMOVED AND DISPOSED OF AS NECESSARY TO ENABLE WORK TO BE COMPLETED. UNDERGROUND UTILITIES LABELED "TO REMAIN" SHALL BE PROTECTED. SAVING OR REMOVAL OF UNDERGROUND OBSTRUCTIONS NOT SHOWN ON THE PLAN SHALL BE COORDINATED WITH THE PROJECT OWNER OR THEIR REPRESENTATIVE.
10. BORING AND SOIL PROBE LOCATIONS TAKEN FROM GEOTECHNICAL REPORT PREPARED BY S.W. COLE DATED FEBRUARY 2019.
11. UTILITY WORK OUTSIDE PAVEMENT DISTURBANCE LIMIT SHOWN ON PLAN WILL RESULT IN ADDITIONAL PAVEMENT RECONSTRUCTION IN ACCORDANCE WITH THE TRENCH DETAIL SHOWN ON SHEET C401.
12. WHERE FINISH PAVEMENT OR GRAVEL GRADE IS BELOW EXISTING GRADE (CUT CONDITION), CONTRACTOR TO PROVIDE FULL DEPTH GRAVEL CONSTRUCTION. WHERE FINISH PAVEMENT OR GRAVEL GRADE IS ABOVE EXISTING GRADE (FILL CONDITION), CONTRACTOR TO REMOVE PAVEMENT, COMPACT EXISTING GRAVEL BASE, AND PROVIDE GRAVEL TO BOTTOM OF PAVEMENT SECTION OR GRAVEL SURFACE.

PAVEMENT LEGEND	
	STANDARD DUTY BITUMINOUS CONCRETE
	REINFORCED CEMENT CONCRETE
	GRAVEL WITHIN LIMITS OF WORK

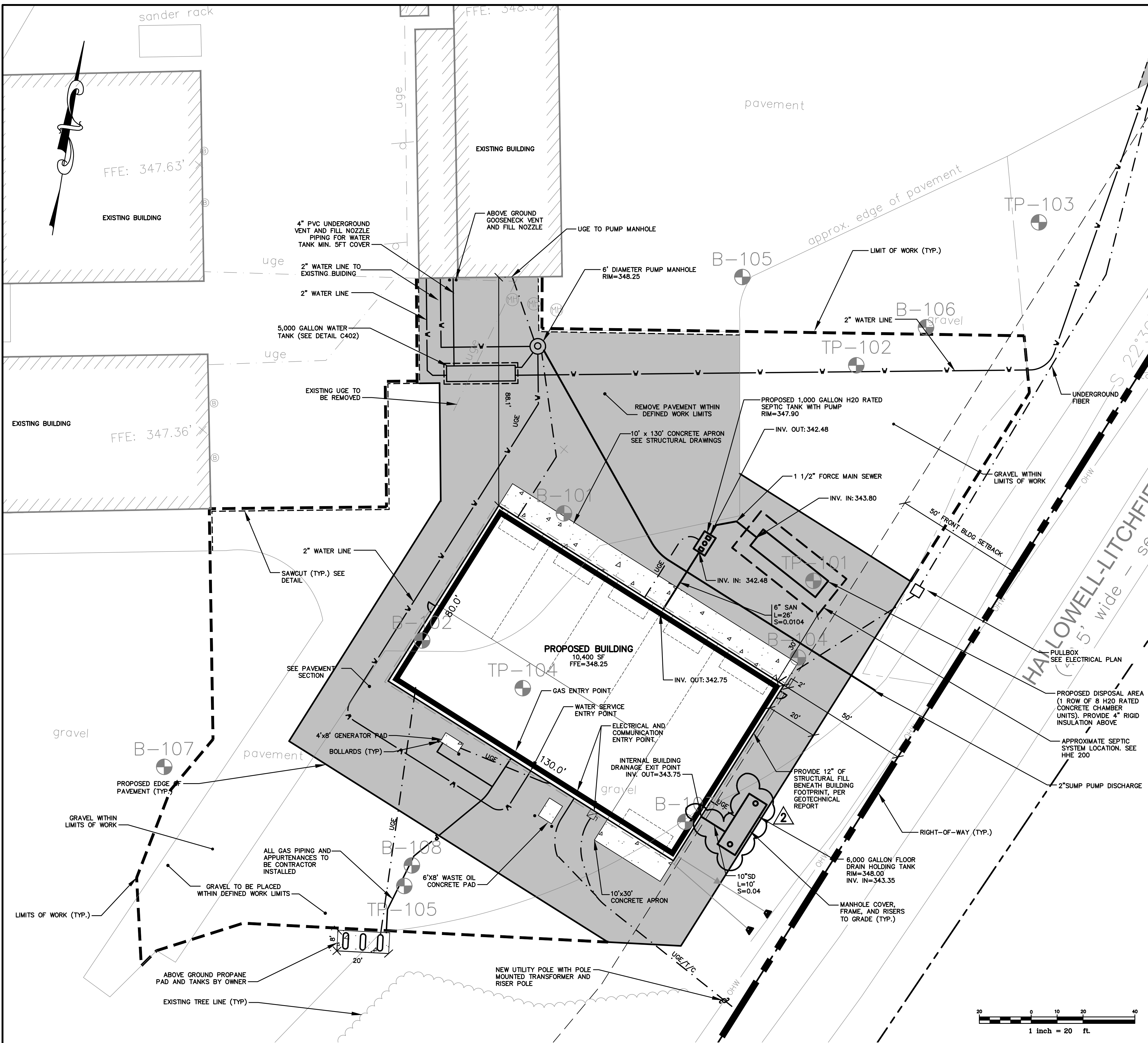

Scale: 1"=20'

No.	Revision	By	Date
1	ISSUED FOR BID	DER	10/15/19
2	ADDENDUM 1	DER	10/31/19

Designed by:

 DOUGLAS E. REYNOLDS

By	Date	By	Date
Designed: DJG	10/15/2019	Checked: DER	10/15/2019
Drawn: CG	10/15/2019		



THE GOLD STAR MEMORIAL HIGHWAY

MTA PROJECT MANAGER: **Brian A. Taddeo, P.E.**

CONTRACT 2019.12, NEW MECHANICS GARAGE, LITCHFIELD MAINTENANCE YARD, MILE MARKER 92.7
SITE AND UTILITY PLAN

SHEET NUMBER: C-101
 CONTRACT: 2019.12
 3 OF 41

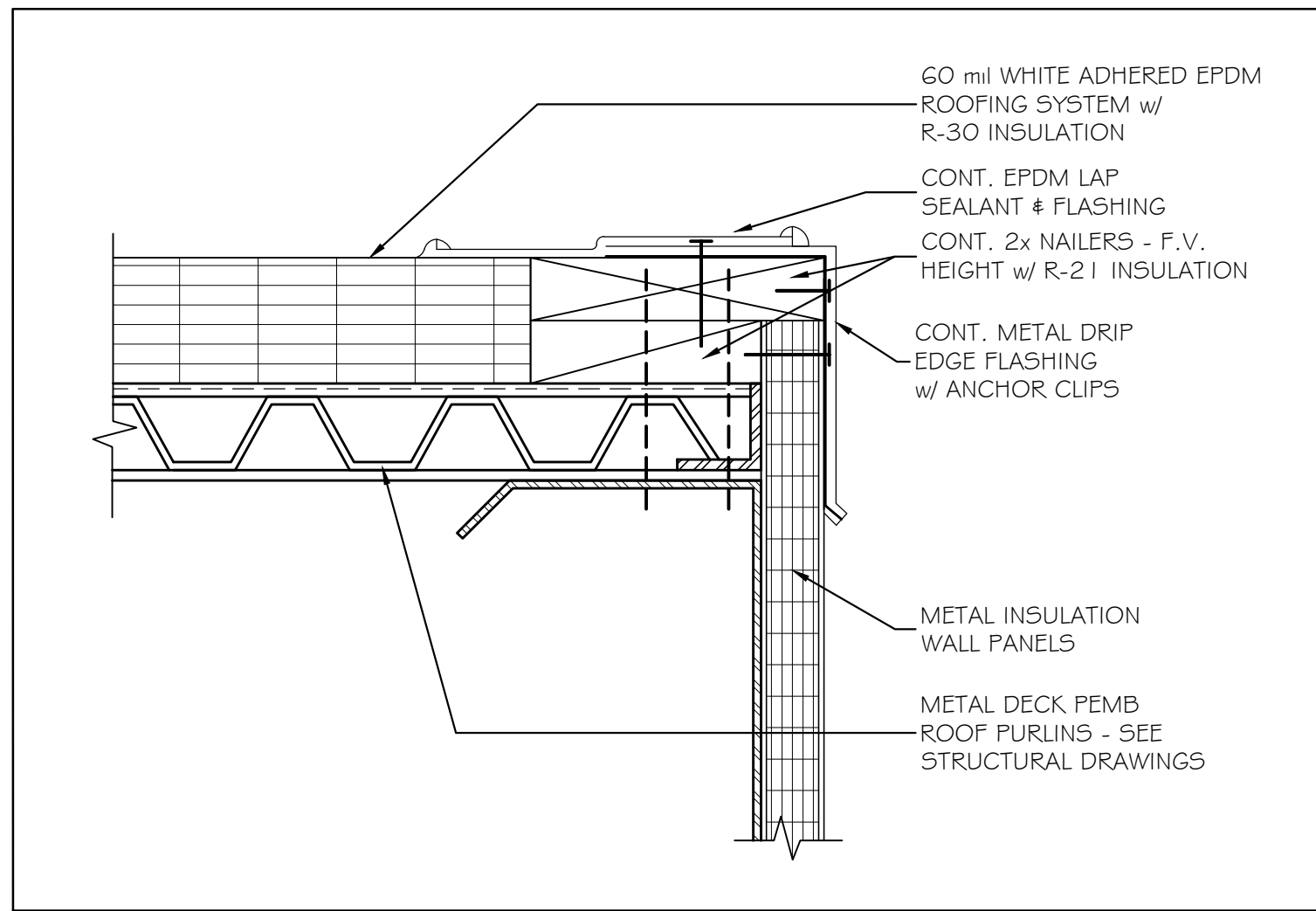

① ROOF EDGE DETAIL (HIGH POINT) NTS

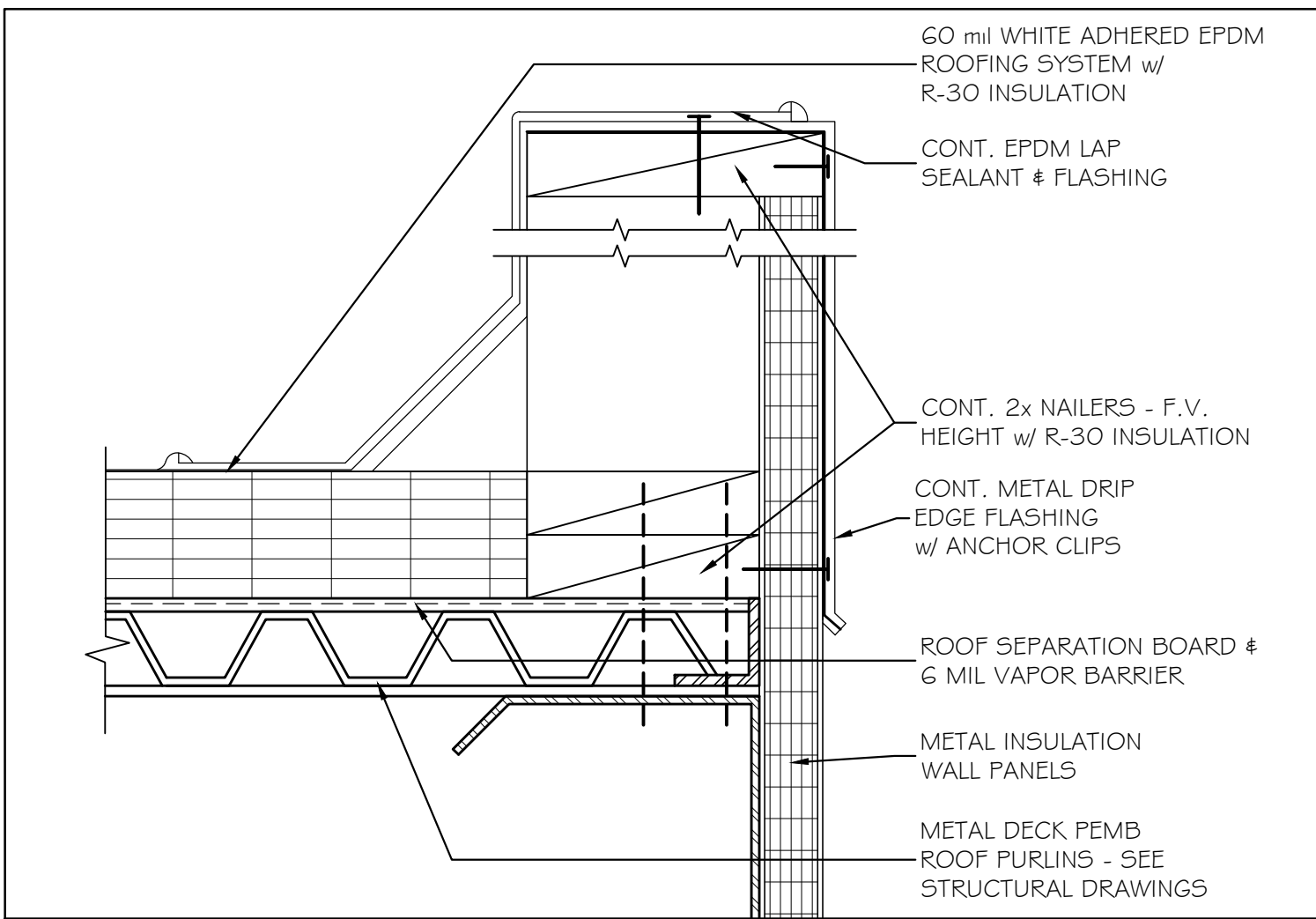

② ROOF EDGE DETAIL (LOW POINT) NTS

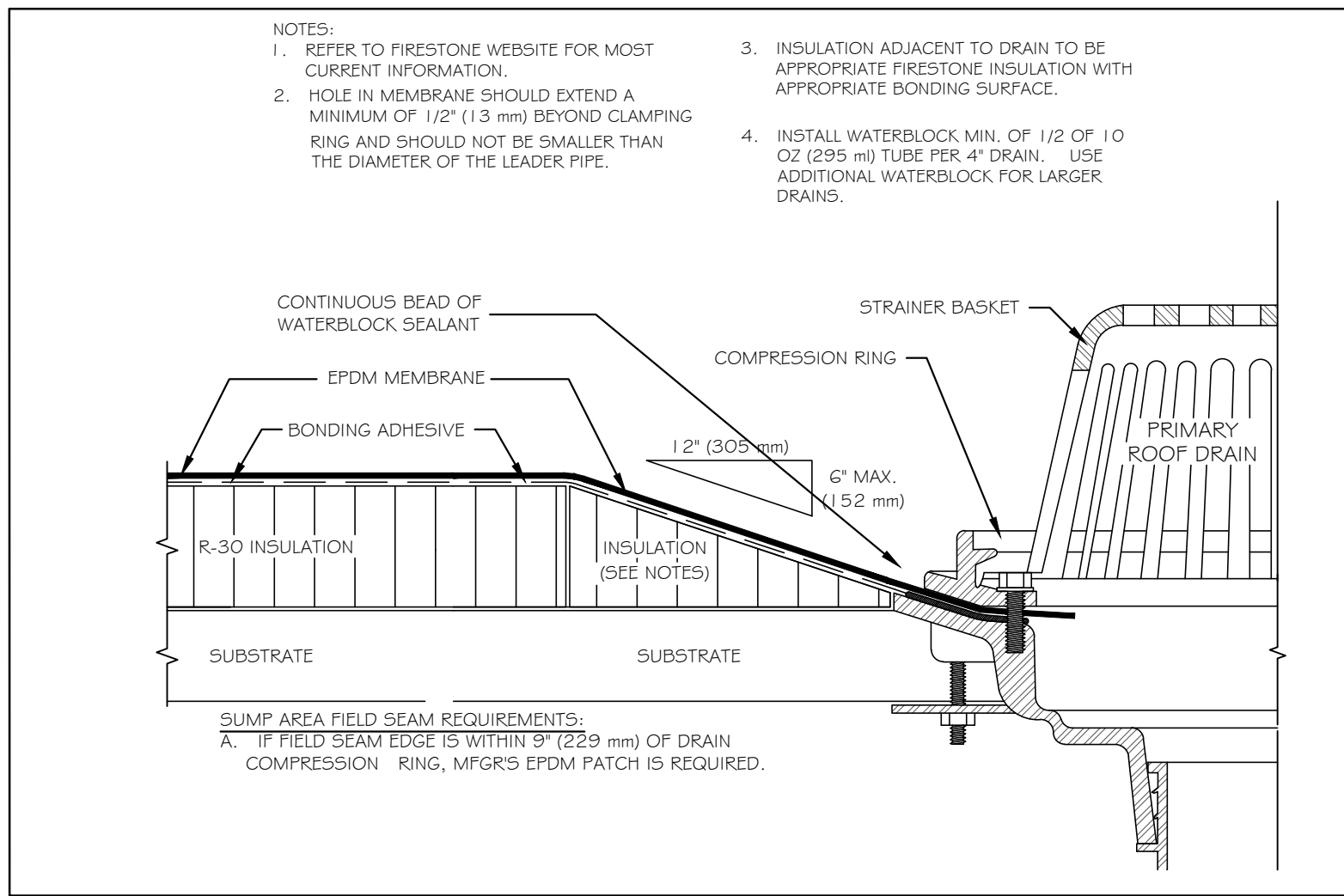

③ ROOF DRAIN DETAIL NTS

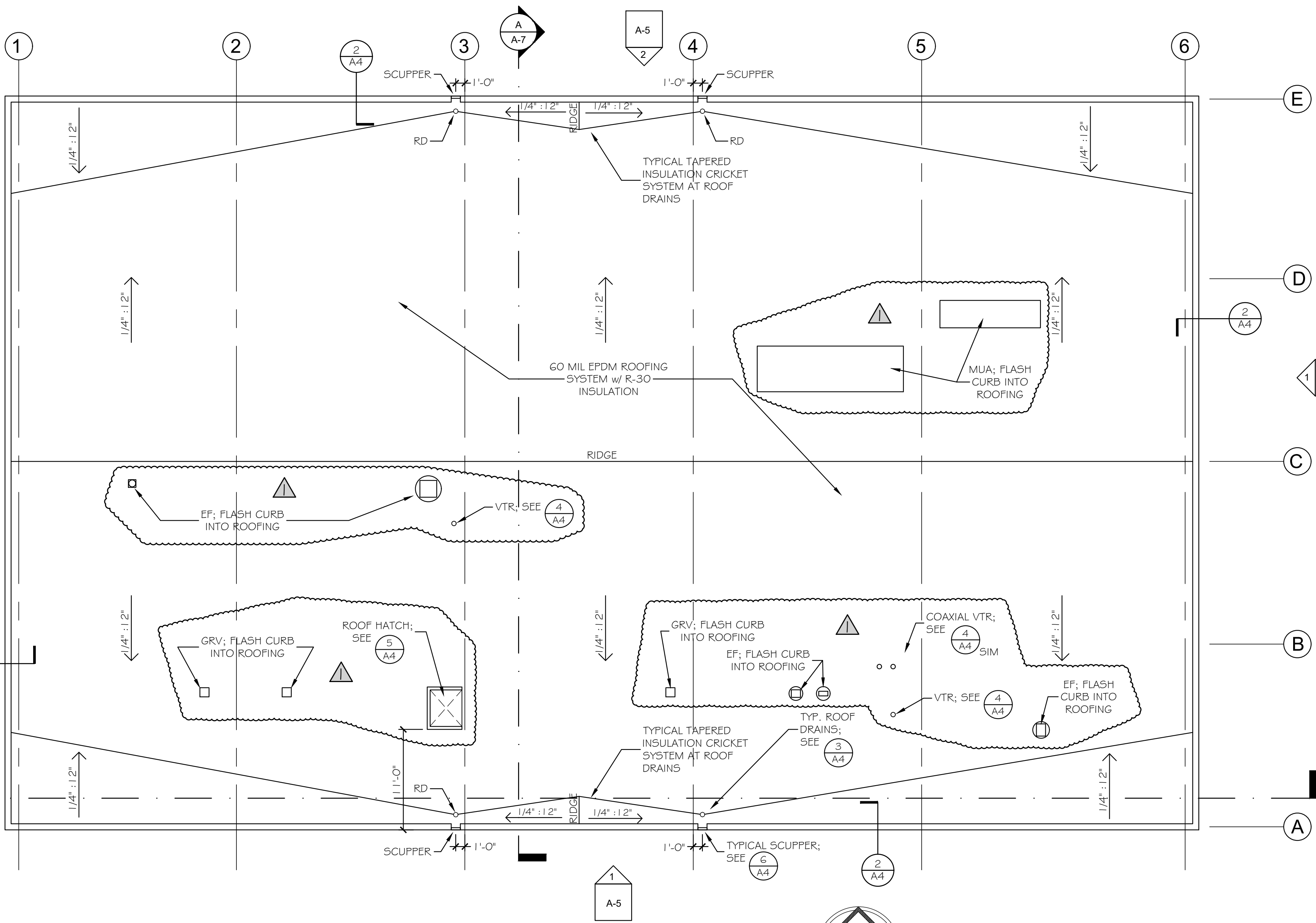

ROOF PLAN
 SCALE: 1/8" = 1'-0"

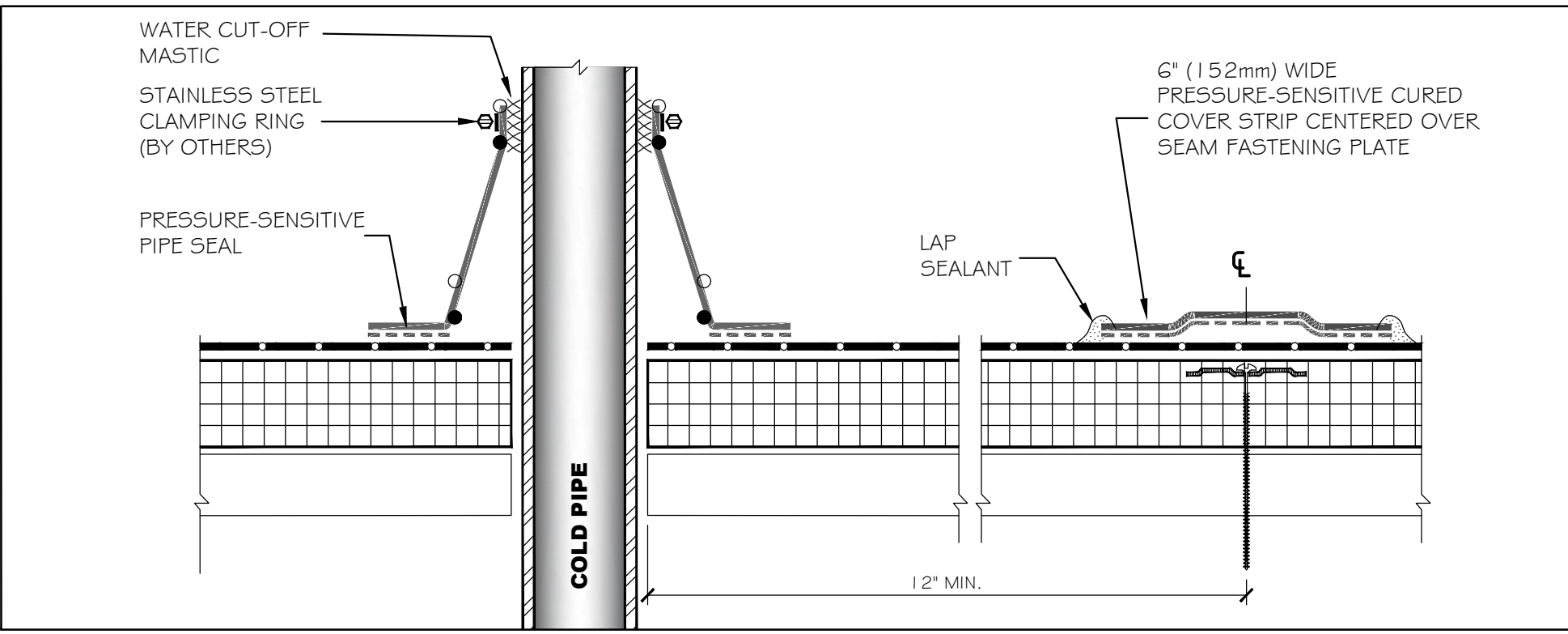

④ PIPE / VENT THROUGH ROOF NTS

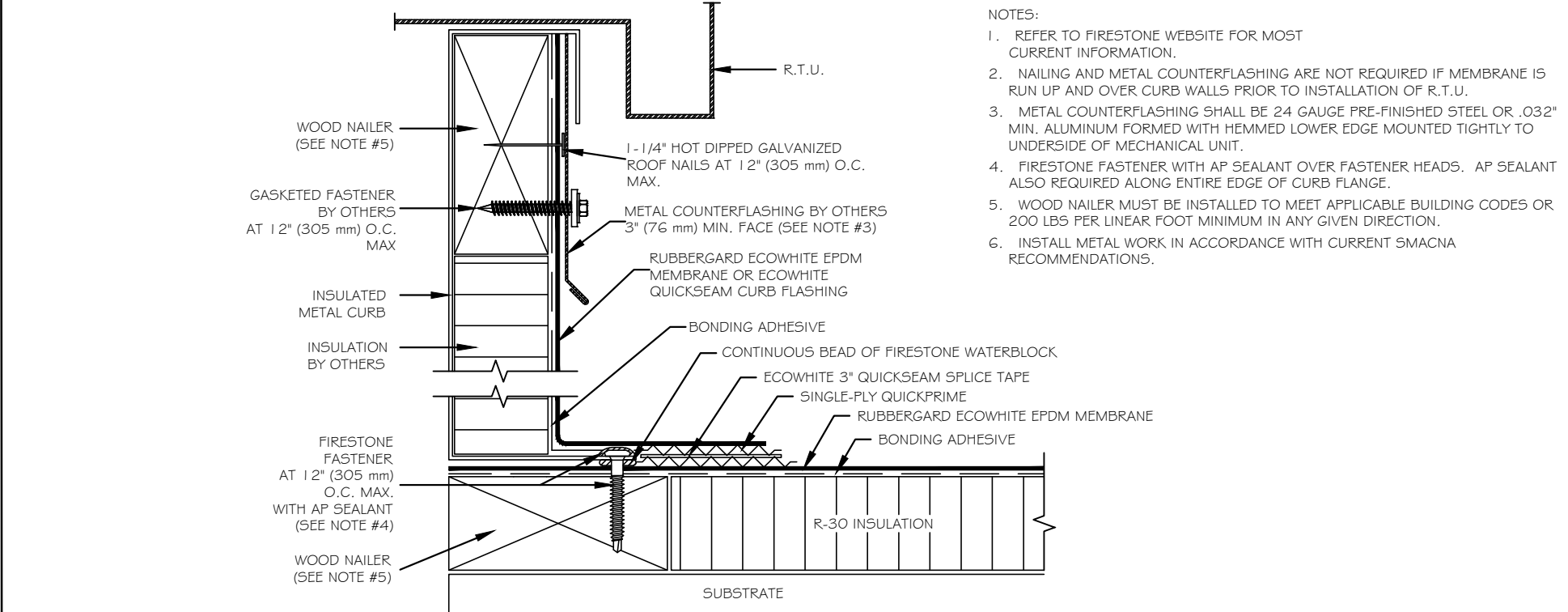

⑤ ROOF HATCH NTS

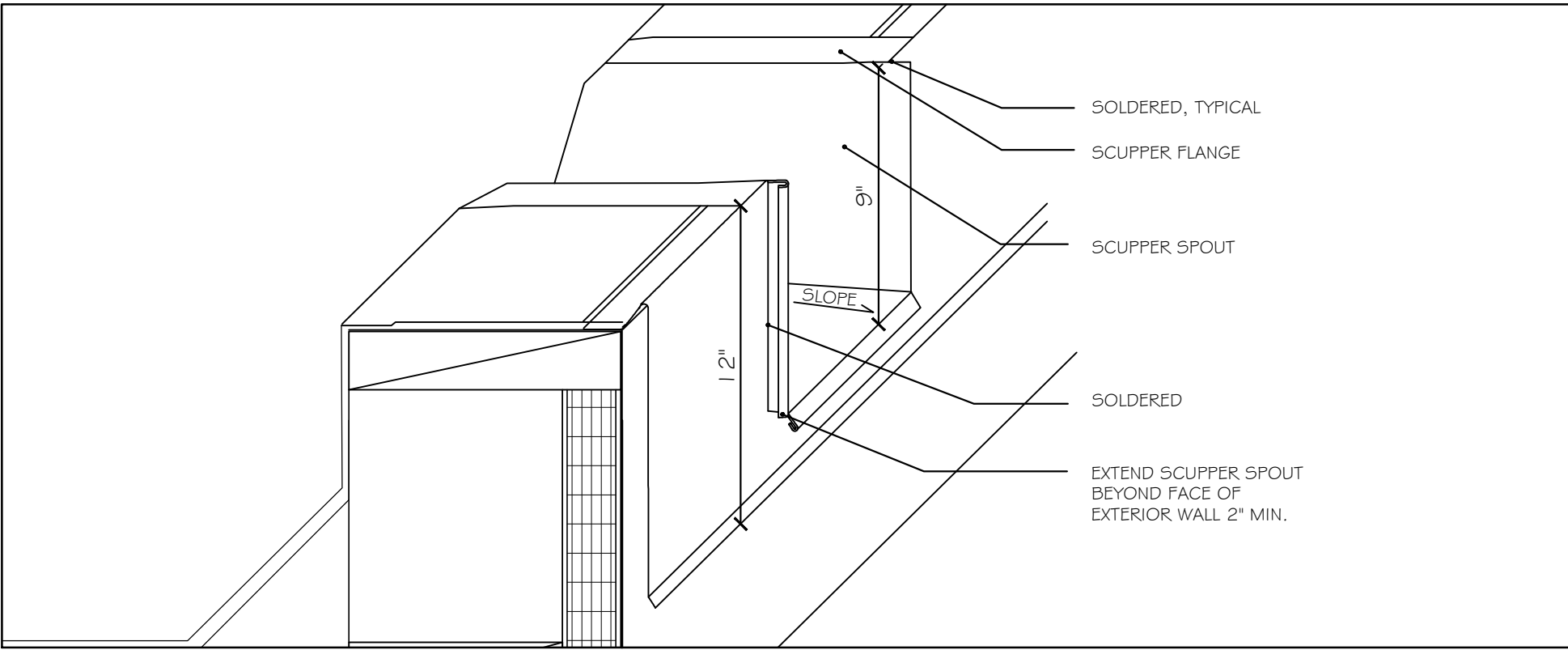

⑥ SCUPPER DETAIL NTS

Scale:

No.	Revision	By	Date
1	ISSUED FOR BID	AEI	10/15/19
2	ADDENDUM 1	AEI	10/31/19

Designed by:
 Michael F. Hays, RA

By	Date	By	Date
Designed: MFH	10/15/19	Checked: MFH	10/15/19
Drawn: MGK	10/15/19		

GRANT HAYS ASSOCIATES
 ARCHITECTURE & INTERIOR DESIGN
 P.O. BOX 6179 FALMOUTH MAINE 04105
 207.871.5900 www.granthays.com

MAINE TURNPIKE
 THE GOLD STAR MEMORIAL HIGHWAY
 MTA PROJECT MANAGER: Brian A. Taddeo, P.E.

CONTRACT 2019.12, NEW MECHANICS GARAGE
 LITCHFIELD MAINTENANCE YARD, MILE MARKER 92.7
 ROOF PLAN & DETAILS

SHEET NUMBER: A-4
 CONTRACT: 2019.12
 11 OF 41

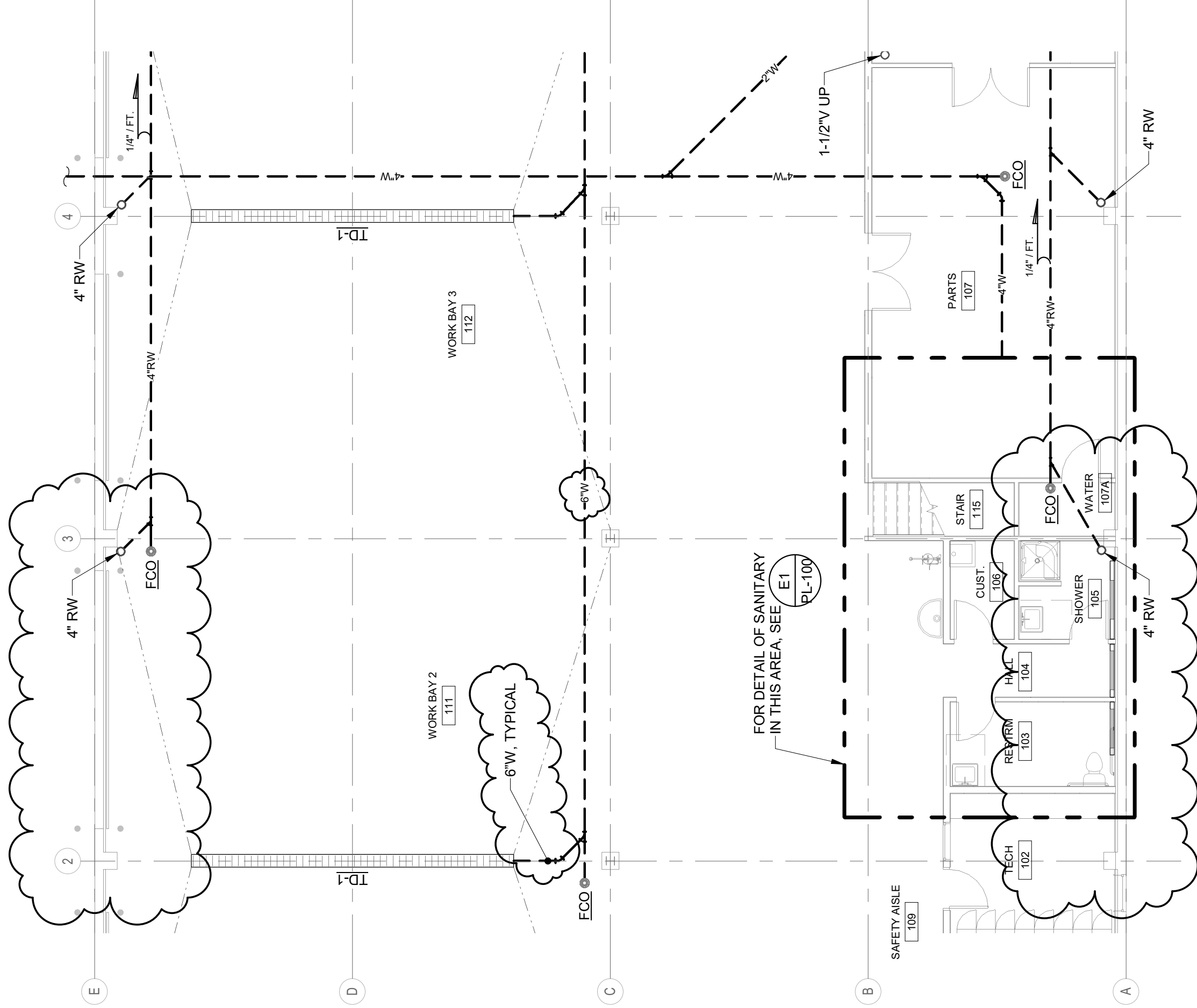

**REVISED FLOOR DRAIN WASTE AND RAIN WATER PIPING
- A4 - SHEET PL-100**

CONTRACT 2019.12, NEW MECHANICS GARAGE LITCHFIELD MAINTENANCE YARD,
MILE MARKER 92.7



Allied Engineering
Structural Mechanical Electrical Commissioning

160 Veranda Street
Portland, Maine 04103
T: 207.221.2260
F: 207.221.2266
Web: www.allied-eng.com

SKP-01
ADDENDUM #1

Scale: 1/8" = 1'-0"

Date: 11/01/19

Project No: 18080

CAD File:

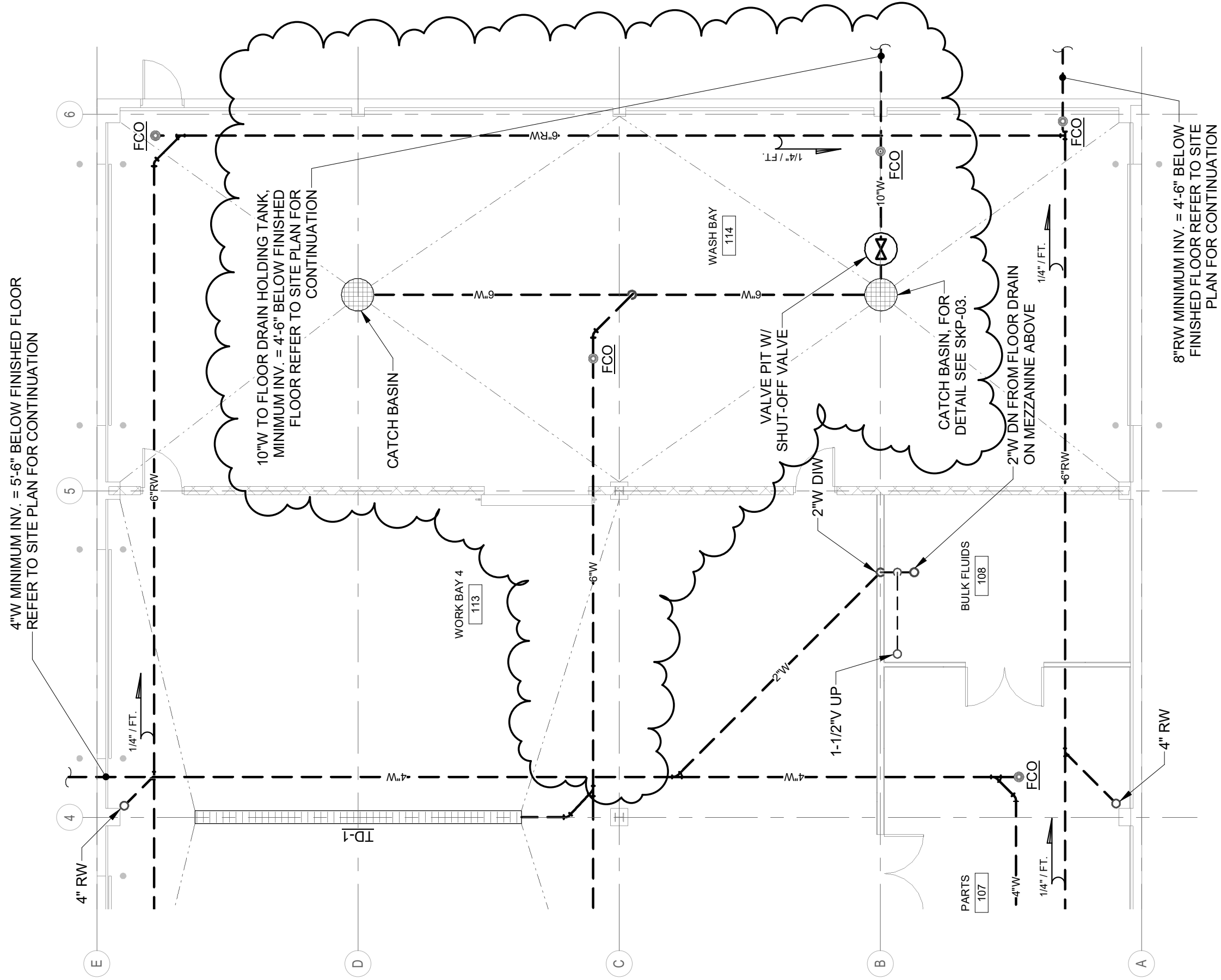

4" RW MINIMUM INV. = 5'-6" BELOW FINISHED FLOOR
REFER TO SITE PLAN FOR CONTINUATION

10" W TO FLOOR DRAIN HOLDING TANK,
MINIMUM INV. = 4'-6" BELOW FINISHED
FLOOR REFER TO SITE PLAN FOR
CONTINUATION

CATCH BASIN

WORK BAY 4
113

WASH BAY
114

VALVE PIT W/
SHUT-OFF VALVE

CATCH BASIN, FOR
DETAIL SEE SKP-03.

2" W DN FROM FLOOR DRAIN
ON MEZZANINE ABOVE

BULK FLUIDS
108

PARTS
107

4" RW

8" RW MINIMUM INV. = 4'-6" BELOW
FINISHED FLOOR REFER TO SITE
PLAN FOR CONTINUATION

REVISED FLOOR DRAIN WASTE AND RAIN WATER PIPING
- A4 - SHEET PL-100

CONTRACT 2019.12, NEW MECHANICS GARAGE LITCHFIELD MAINTENANCE YARD,
MILE MARKER 92.7

Scale: 1/8" = 1'-0"

Date: 11/01/19

Project No: 18080

CAD File:

SKP-02
ADDENDUM #1



160 Veranda Street
Portland, Maine 04103
T: 207.221.2260
F: 207.221.2266
Web: www.allied-eng.com

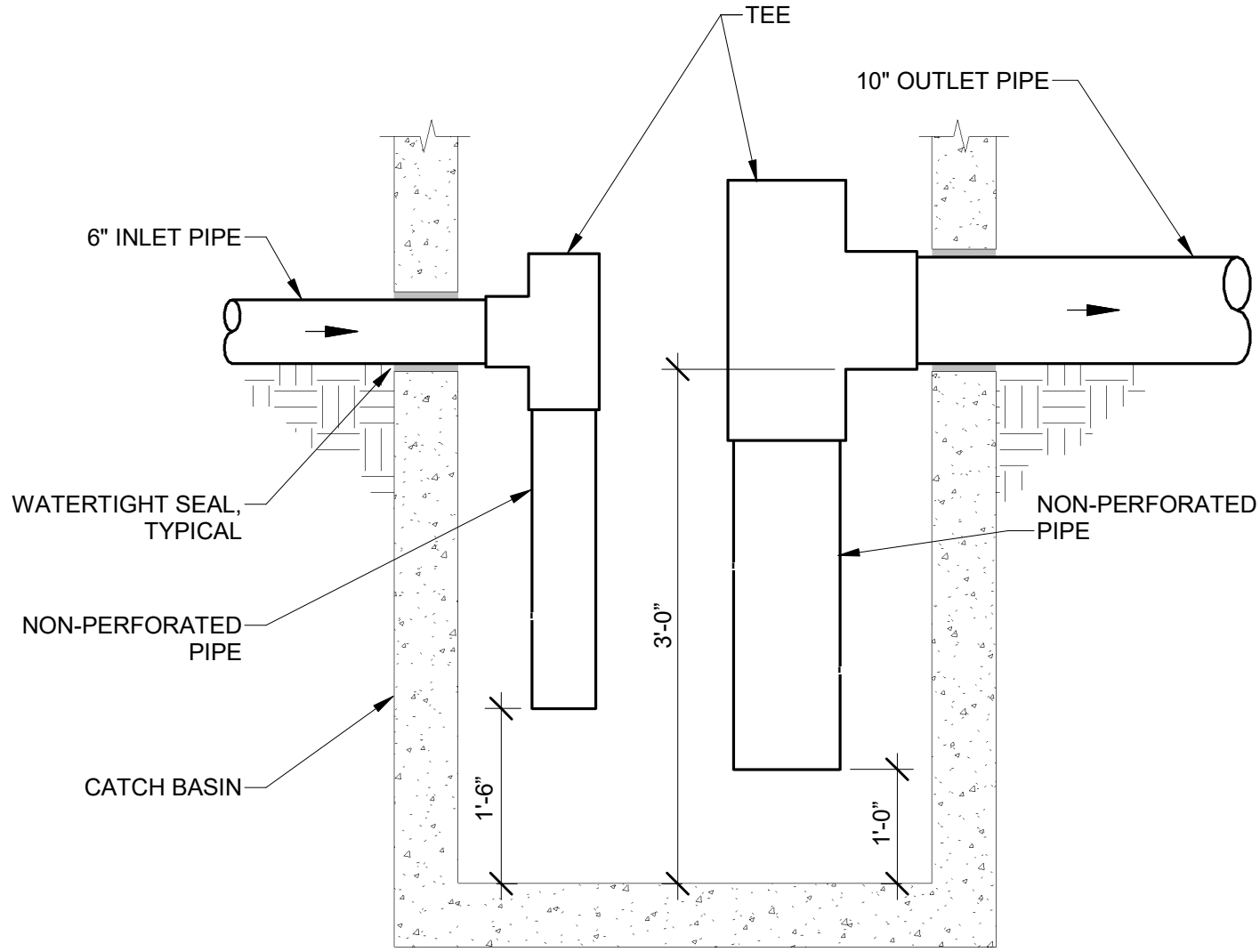

Allied Engineering
 Structural Mechanical Electrical Plumbing
 160 Veranda Street
 Portland, Maine 04103
 P: 207.221.2260
 F: 207.221.2266
 Web: www.allied-eng.com

OIL AND GRIT SEPARATOR DETAIL	
CONTRACT 2019.12, NEW MECHANICS GARAGE LITCHFIELD MAINTENANCE YARD, MILE MARKER 92.7	
Scale: NOT TO SCALE	Project No: 18080
Date: 11/01/19	CAD File:

SKP-03
 Addendum # 1

<p>A AMPERE MC MICROPHONE</p> <p>AC ALTERNATING CURRENT MW MICROWAVE</p> <p>AFB ABOVE FINISHED FLOOR MLO MAIN LUG ONLY</p> <p>AFG ABOVE FINISHED GRADE MT MOUNT</p> <p>AHU AIR HANDLING UNIT MTS MANUAL TRANSFER SWITCH</p> <p>AIC AMPERES INTERRUPTING... MCP MOTOR CONTROL PANEL</p> <p>ATS AUTOMATIC TRANSFER SWITCH MH METAL HALIDE</p> <p>AWG AMERICAN WIRE GAUGE MDP MAIN DISTRIBUTION PANEL</p> <p>BAS BUILDING AUTOMATION SYSTEM MN MINIMUM</p> <p>BKBD BACKBOARD N NEUTRAL</p> <p>C CONDUIT NC NORMALLY CLOSED</p> <p>CAT CATALOG, CATEGORY NEC NATIONAL ELECTRICAL CODE</p> <p>CATV CABLE TV NEMA NATIONAL ELECTRICAL...</p> <p>CB CIRCUIT BREAKER NFPA NATIONAL FIRE PROTECTION...</p> <p>CCV CLOSED CIRCUIT TELEVISION NIC NOT IN CONTRACT</p> <p>CM CIRCULAR MILS NF NON-FUSED</p> <p>COMM COMMUNICATIONS NO NORMALLY OPEN</p> <p>CU MECH CONDENSING UNIT NO, # NUMBER</p> <p>CU COPPER NTS NOT TO SCALE</p> <p>CUH CABINET UNIT HEATER OC ON CENTER</p> <p>CR CORD REEL</p> <p>DC DIRECT CURRENT OCC OCCUPANCY</p> <p>DDC DIGITAL DIRECT CONTROL OH OVERHEAD</p> <p>DN DOWN P POLE</p> <p>DW DISHWASHER PA PUBLIC ADDRESS</p> <p>DWG DRAWING PB PULLBOX</p> <p>EF EXHAUST FAN PH, Ø PHASE</p> <p>ELEV ELEVATOR PIR PASSIVE INFRARED</p> <p>EMT ELECTRICAL METALLIC TUBING PNL PANELBOARD</p> <p>EP EXPLOSION PROOF PVO PART OF</p> <p>ERU ENERGY RECOVERY UNIT PV PHOTOVOLTAIC</p> <p>EWC ELECTRIC WATER COOLER PVC POLY-VINYL CHLORIDE</p> <p>FACP FIRE ALARM CONTROL PANEL REC RECEPTACLE</p> <p>FB FLOOR BOX REF REFRIGERATOR</p> <p>FLA FULL LOAD AMPS RF RETURN FAN</p> <p>FWE FURNISHED WITH EQUIPMENT RGS RIGID GALVANIZED STEEL</p> <p>G, GND GROUND RM ROOM</p> <p>GFCI GROUND FAULT CIRCUIT... RMC RIGID METAL CONDUIT</p> <p>GFP GROUND FAULT PROTECTION RTU ROOFTOP UNIT</p> <p>HID HIGH INTENSITY DISCHARGE REF REFRIGERATOR</p> <p>HOA HAND-OFF-AUTO SELECTOR... SF SUPPLY FAN</p> <p>HP HORSEPOWER SPDT SINGLE POLE, DOUBLE THROW</p> <p>HVAC HEATING, VENTILATION AND... SQ SQUARE</p> <p>IDS INTRUSION DETECTION SYSTEM TEL TELEPHONE</p> <p>IG ISOLATED GROUND TVSS TRANSIENT VOLTAGE SURGE...</p> <p>IMC INTERMEDIATE METAL CONDUIT TYP TYPICAL</p> <p>IR INFRARED UFP UNDER FLOOR</p> <p>K KILO UG UNDERGROUND</p> <p>KCMIL KILO CIRCULAR MILS UH UNIT HEATER</p> <p>KW KILOWATT UL UNDERWRITER'S LABORATORY</p> <p>KVA KILO VOLT-AMPS UNO UNLESS NOTED OTHERWISE</p> <p>LAN LOCAL AREA NETWORK UPS UNINTERRUPTIBLE POWER SUPPLY</p> <p>LC LIGHTING CONTACTOR V VOLTS</p> <p>LF LINEAR FEET VFD VARIABLE FREQUENCY DRIVE</p> <p>LC LOADCENTER W WATT</p> <p>LCP LIGHTING CONTROL PANEL WP WEATHERPROOF</p> <p>LED LIGHT EMITTING DIODE WG WIREGUARD</p> <p>LTG LIGHTING XFMR TRANSFORMER</p> <p>LTS LIGHTS</p> <p>MAX MAXIMUM (E) EXISTING ITEM TO REMAIN</p> <p>MCB MAIN CIRCUIT BREAKER (R) REMOVE ITEM AND DISPOSE OF...</p> <p>MECH MECHANICAL (ER) RELOCATED ITEM AT NEW...</p> <p>MH MOUNTING HEIGHT (RL) REMOVE AND RELOCATE</p>	<p style="text-align: center;">LIGHTING SWITCHES</p> <p>Sa LIGHT SWITCH, 20A, 125V/277V</p> <p>S3 THREE-WAY LIGHT SWITCH</p> <p>S4 FOUR-WAY LIGHT SWITCH</p> <p>S2 TWO-POLE SWITCH</p> <p>Sk KEY OPERATED SWITCH</p> <p>Sm MOTOR RATED SWITCH</p> <p>Sp SINGLE POLE SWITCH WITH RED PILOT LIGHT ~ RED LIGHT SHALL GLOW WHEN CIRCUIT IS ENERGIZED</p> <p>Sa Multi-ganged switches, gang under one plate, letter indicates switching</p> <p>Sb</p> <p>Sos OCCUPANCY SENSOR SWITCH, WALL MOUNTED</p> <p>Sos2 2-BUTTON OCCUPANCY SENSOR SWITCH</p> <p>Sos3 OCCUPANCY SENSOR SWITCH WIRED FOR 3-WAY OPERATION</p> <p>Sosd OCCUPANCY SENSOR SWITCH WITH DIMMING ~ COORDINATE DIMMING TECHNOLOGY WITH LOAD TO BE DIMMED</p> <p>CS OCCUPANCY SENSOR, CEILING MOUNTED</p> <p>CS- OCCUPANCY SENSOR, WALL MOUNTED</p> <p>DS DAYLIGHT SENSOR</p> <p>SD DIMMER SWITCH ~ COORDINATE DIMMING TECHNOLOGY WITH LOAD TO BE DIMMED</p> <p>SF HANDICAP SWITCHES FOR HOOD LIGHT AND FAN</p> <p>SLV LOW VOLTAGE LIGHT SWITCH, MOMENTARY CONTACT GROUPS</p> <p>SLVab LOW VOLTAGE LIGHT SWITCH CONTROLLING MULTIPLE LIGHTING</p> <p>LTC LIGHTING TIME CLOCK</p> <p>LC LIGHTING CONTACTOR</p> <p>LCP LIGHTING CONTROL PANEL</p> <p>PC OUTDOOR PHOTOELECTRIC SWITCH</p> <p>NOTES:</p> <ol style="list-style-type: none"> MOUNT LIGHT SWITCHES WITH CENTERLINE 48" AFF, UNO LOWER CASE LETTER AT SWITCH INDICATES SWITCHING <p style="text-align: center;">EMERGENCY LIGHTING</p> <p>HATCHING INDICATES EGRESS FIXTURE. PROVIDE UL924 RELAYS TO AUTOMATICALLY TURN EGRESS LIGHTING ON TO FULL BRIGHTNESS UPON LOSS OF NORMAL POWER REGARDLESS OF THE LIGHTING CONTROL STATUS. "EM" INDICATES EMERGENCY WHERE SYMBOL HATCHING IS UNCLEAR</p> <p>EXIT SIGN, CEILING MOUNTED, SHADING INDICATES FACE(S) ARROWHEAD INDICATES CHEVRON(S) REQUIRED, CONNECT TO UNSWITCHED PORTION OF AREA LIGHTING BRANCH CIRCUIT, U.N.O.</p> <p>EXIT SIGN, WALL MOUNTED, SHADING INDICATES FACE(S) MOUNT AT 7'-6" AFF OR OVER DOOR, CONNECT TO UNSWITCHED PORTION OF AREA LIGHTING BRANCH CIRCUIT, U.N.O.</p> <p>INV CENTRAL LIGHTING INVERTER</p> <p style="text-align: center;">REFER TO LUMINAIRE SCHEDULE FOR FIXTURE TYPES</p> <p style="text-align: center;">TYPICAL FOR ALL FIXTURE TYPES :</p> <p>R1 INDICATES LUMINAIRE TYPE ON SCHEDULE</p> <p>a LOWER CASE LETTER INDICATES SWITCH GROUP</p>	<p style="text-align: center;">SINGLE RECEPTACLES</p> <p>MOUNT 48" AFF U.N.O.</p> <p>REFER TO SPECIAL RECEPTACLE SCHEDULE</p> <p>OVERHEAD SINGLE RECEPTACLE CORD DROP</p> <p>NOTE:</p> <p>PROVIDE MATCHING CORD AND PLUG FOR SINGLE RECEPTACLES FOR NEW EQUIPMENT AND WHERE NOTED FOR RELOCATED EQUIPMENT</p> <p style="text-align: center;">FLOOR AND CEILING DEVICES</p> <p>F DUPLEX RECEPTACLE, 20A, 125V, 2P, 3W, NEMA 5-20R, MOUNT IN FLUSH FLOOR BOX</p> <p>F DOUBLE DUPLEX RECEPTACLE, 20A, 125V, 2P, 3W, NEMA 5-20R, MOUNT IN FLUSH FLOOR BOX</p> <p>P DUPLEX RECEPTACLE, PEDESTAL MOUNTED</p> <p>P SINGLE RECEPTACLE, PEDESTAL MOUNTED</p> <p>C DUPLEX RECEPTACLE, FLUSH MOUNTED IN CEILING</p> <p>C DOUBLE DUPLEX RECEPTACLE, FLUSH MOUNTED IN CEILING</p> <p>C DOUBLE GFCI RECEPTACLE, FLUSH MOUNTED IN CEILING</p> <p>CR OVERHEAD RECEPTACLE DROP, DUPLEX ~ CR= CORD REEL</p> <p>CR OVERHEAD RECEPTACLE DROP, DOUBLE DUPLEX ~ CR= CORD REEL</p> <p>CR OVERHEAD RECEPTACLE DROP, GFCI ~ CR= CORD REEL</p> <p>MULTI-SERVICE FLUSH FLOOR BOX ~ WIREMOLD EFB45 SERIES OR APPROVED EQUAL. COVER SHALL BE FLUSH STYLE WITH FLOOR INSERT. COVER FINISH COLOR SHALL BE SELECTED BY ARCHITECT FROM MANUFACTURER'S STANDARD FINISHES.</p> <p>DATA OUTLET IN FLUSH FLOOR BOX</p> <p>2-GANG JUNCTION BOX IN FLUSH FLOOR BOX</p> <p style="text-align: center;">RECEPTACLES</p> <p>⊕ DUPLEX RECEPTACLE ~ 20A, 125V, 2P, 3W, NEMA 5-20R</p> <p>⊕⊕ DOUBLE DUPLEX RECEPTACLE</p> <p>⊕⊕ HATCHING INDICATES RECEPTACLE WITH INSULATED/ ISOLATED GROUND</p> <p>⊕⊕ GFCI DUPLEX RECEPTACLE, MOUNT 46" AFF UNO</p> <p>⊕⊕ GFCI DOUBLE DUPLEX RECEPTACLE, MOUNT 46" AFF UNO</p> <p>ewc GFCI RECEPTACLE FOR ELECTRIC WATER COOLER - COORDINATE LOCATION WITH DIVISION 22</p> <p>wp GFCI RECEPTACLE WITH WEATHERPROOF COVER</p> <p>wp GFCI RECEPTACLE IN WP ENCLOSURE ON ROOF</p> <p>— SURFACE RACEWAY, MOUNT 44" AFF UNO. PROVIDE NEMA 5-20 RECEPTACLES AT 24" OC</p> <p>P POWER POLE USED AS RACEWAY ~ VERTICAL POWER SYSTEMS SL-EXP</p> <p>▷ P POWER POLE WITH DEVICES ~ VERTICAL POWER SYSTEMS PP-EXP</p> <p>NOTES:</p> <ol style="list-style-type: none"> MOUNT RECEPTACLES WITH CENTERLINE 18" AFF UNO MOUNT EXTERIOR RECEPTACLES WITH CENTERLINE 24" AFF UNO 	<p>2</p> <p>CAMERA ~ PROVIDE CAMERA AND SINGLE GANG BOX WITH 3/4" CONDUIT. MOUNTING HEIGHT AND LOCATION SHALL BE CONFIRMED WITH OWNER PRIOR TO ROUGH-IN.</p> <p>CR CARD READER ~ PROVIDE RECESSED WALL MOUNTED SINGLE-GANG BOX 44" AFF WITH 3/4" CONDUIT. EXTERIOR BOXES SHALL BE WEATHERPROOF. DIVISION 26 TO PROVIDE 3/4" CONDUIT FROM CARD READER TO JUNCTION BOX FOR SECURITY PANEL LOCATED IN IO.T.203. FURNISH AND INSTALL ACCESS CONTROL CABLE (TAPPAN MODEL H91602-1) PER MTA REQUIREMENTS. COORDINATE LOCATION OF SECURITY PANEL WITH OWNER. CARD READER (MODEL ALLEGIAN MT15) PROVIDED BY OTHERS.</p> <p>L DOOR LOCK ~ PROVIDE EMPTY 1/2" RECESSED CONDUIT WITH PULL STRING IN DOOR FRAME, RUN FROM DOOR LOCK LOCATION IN FRAME TO DOOR LOCK POWER LOCATION.</p> <p>D DOOR LOCK POWER ~ WIRE AND CONNECT TO CIRCUIT P1-41. POWER SUPPLIES BY OTHERS.</p> <p>SE DOOR POSITION SWITCH ~ PROVIDE 3/4" RECESSED CONDUIT TO DOOR FRAME HEADER 6" FROM LATCH SIDE.</p> <p>SAA SECURITY PANEL ANNUNCIATOR (DIV 28)</p> <p>NOTES:</p> <ol style="list-style-type: none"> DOOR HARDWARE BY DIV 8 U.N.O. LOW VOLTAGE WIRING AND DEVICES BY OWNER UNLESS NOTED OTHERWISE. CONDUITS SHALL BE RUN CONCEALED FROM EACH OUTLET BOX OR TERMINATION TO 6" ABOVE THE NEAREST ACCESSIBLE CORRIDOR CEILING THAT IS CONTIGUOUS TO THE NEAREST IT ROOM, J-HOOK OR CABLE TRAY PATHWAY, UNO. IN ROOMS WITHOUT CEILINGS, CONDUIT SHALL BE RUN AT UNDERSIDE OF DECK TO 6" ABOVE THE NEAREST ACCESSIBLE CORRIDOR CEILING THAT IS CONTIGUOUS TO THE NEAREST IT ROOM, J-HOOK OR CABLE TRAY PATHWAY, UNO. CONDUIT PATHWAYS SHALL BE PROVIDED FOR ANY PORTIONS OF THE PATH TO NEAREST IT ROOM, J-HOOK OR CABLE TRAY THAT HAS EXPOSED DECK OR HAS INACCESSIBLE CEILINGS. DIVISION 26 SHALL PROVIDE 120 VOLT POWER WHERE INDICATED. DIV 26 SHALL PROVIDE EMPTY BOXES AND CONDUITS WITH PULL STRING U.N.O. <p style="text-align: center;">D7 SECURITY LEGEND</p> <p>12" = 1'-0"</p> <p>AS AF FUSED DISCONNECT SWITCH</p> <p>NON-FUSED DISCONNECT SWITCH</p> <p>00 MOTOR STARTER ~ NUMBER INDICATES NEMA SIZE</p> <p>00 COMBINATION MOTOR STARTER/FUSED DISCONNECT</p> <p>○ MOTOR OR FAN</p> <p>M METER AND CABINET</p> <p>⊙ JUNCTION BOX</p> <p>⊙- WALL MOUNTED</p> <p>⊙- DOUBLE GANG JUNCTION BOX ~ WALL MOUNTED 18" AFF</p> <p>C JUNCTION BOX ~ FLUSH CEILING MOUNTED</p> <p>P JUNCTION BOX ~ PEDESTAL MOUNTED</p> <p>TF TRANSFORMER ~ NUMBER INDICATES DESIGNATION SEE TRANSFORMER SCHEDULE</p> <p>VFD VARIABLE FREQUENCY DRIVE</p> <p>TVSS TRANSIENT VOLTAGE SURGE SUPPRESSOR</p> <p>⊕- POWER SHUTOFF SWITCH ~ WALL MOUNTED 48" TO CENTER LINE</p> <p>○ CONDUIT TURNING UP</p> <p>○ CONDUIT TURNING DOWN</p> <p>--- WIRING UNDERGROUND OR UNDERSLAB</p> <p>← HOMERUN ~ (2#12+(1#12G UNO (EXCEPT LIGHTING CIRCUITS: (1#12+(1#10N+(1#12G UNO)</p> <p>←← SINGLE-PHASE HOMERUN OR MULTIPLE HOMERUN UTILIZING THE SAME CONDUIT</p> <p>←←← 3-PHASE HOMERUN OR MULTIPLE HOMERUN UTILIZING THE SAME CONDUIT</p> <p>~ FLEXIBLE CONNECTION</p> <p> GROUNDING SYSTEM</p> <p>⊕- MOTORIZED DOOR OPERATOR AND PUSH PADDLE ~ FURNISHED BY DIV 08, WIRED BY DIV 26</p> <p>CB ENCLOSED CIRCUIT BREAKER</p> <p>ATS AUTOMATIC TRANSFER SWITCH</p> <p>H- HAND DRYER, COORDINATE HEIGHT WITH ARCHITECTURAL PLANS</p> <p>⊕ ENCLOSED CONTACTOR</p> <p>⊕ OVERHEAD DATA DROP</p> <p>C DATA OUTLET FLUSH IN CEILING</p>	<p>FACP FIRE ALARM CONTROL PANEL, MOUNT WITH TOP OF PANEL NOT MORE THAN 72" AFF</p> <p>FAA FIRE ALARM ANNUNCIATOR, MOUNT WITH TOP OF PANEL NOT MORE THAN 72" AFF, WIRED TO FACP</p> <p>S SMOKE DETECTOR, WIRED TO FACP</p> <p>S E SMOKE DETECTOR, "E" INDICATES CONNECTION FOR ELEVATOR RECALL, WIRED TO FACP</p> <p>S- SINGLE STATION SMOKE DETECTOR WITH AUDIBLE INDICATING APPLIANCE, WALL MOUNTED</p> <p>SS SS SINGLE STATION SMOKE DETECTOR WITH AUDIBLE/VISUAL INDICATING APPLIANCE, CEILING MOUNTED</p> <p>SS SS SINGLE/MULTI-STATION SMOKE/CARBON MONOXIDE DETECTOR WITH AUDIBLE INDICATING APPLIANCE, CEILING MOUNTED</p> <p>SS SS SINGLE/MULTI-STATION SMOKE/CARBON MONOXIDE DETECTOR WITH AUDIBLE INDICATING APPLIANCE, WALL MOUNTED</p> <p>H HEAT DETECTOR, WIRED TO FACP</p> <p>H E HEAT DETECTOR, "E" INDICATES CONNECTION FOR ELEVATOR RECALL, WIRED TO FACP</p> <p>D DUCT SMOKE DETECTOR, WIRED TO FACP</p> <p>G GAS DETECTOR, WIRED TO FACP</p> <p>FLAME DETECTOR, WIRED TO FACP</p> <p>RTS RTS REMOTE TEST/INDICATOR FOR DUCT SMOKES, MOUNT ON CEILING BENEATH UNIT, OR WALL MOUNT WHERE INDICATED ON PLANS</p> <p>E- MANUAL PULL STATION, MOUNT 48" AFF</p> <p>▷ E- HORN/STROBE, WALL MOUNTED CANDELA AS NOTED ON PLANS, WIRED TO FACP</p> <p>▷ E- HORN/STROBE, CEILING MOUNTED, CANDELA AS NOTED ON PLANS, WIRED TO FACP</p> <p>E- STROBE ONLY INDICATING APPLIANCE, WALL MOUNTED, CANDELA AS NOTED ON PLANS, WIRED TO FACP</p> <p>▷ E- HORN/STROBE WITH PULL STATION DIRECTLY BELOW</p> <p>M- MAGNETIC DOOR HOLD OPEN DEVICE, WIRED TO FACP</p> <p>T TRANSFORMER</p> <p>⊕ SPRINKLER SYSTEM WATER FLOW SWITCH, PROVIDED UNDER DIVISION 23, WIRED TO FACP UNDER DIVISION 26</p> <p>⊕ SPRINKLER SYSTEM TAMPER SWITCH, PROVIDED UNDER DIVISION 23, WIRED TO FACP UNDER DIVISION 26</p> <p>⊕ SPRINKLER SYSTEM CHECK VALVE PRESSURE SWITCH, FURNISHED AND INSTALLED UNDER DIVISION 23, WIRED TO FACP UNDER DIVISION 26</p> <p>⊕ SPRINKLER SYSTEM PRE-ACTION VALVE, FURNISHED AND INSTALLED UNDER DIVISION 21, WIRED TO FACP UNDER DIVISION 26</p> <p>K- KNOX BOX, MOUNT 60" AFF</p> <p>SD SMOKE DAMPER, WIRED TO FACP</p> <p>FSD FIRE AND SMOKE DAMPER, WIRED TO FACP HORN/STROBE, CANDELA AS NOTED ON PLANS, WIRED TO FACP</p> <p>▷ S- SPEAKER/STROBE, WALL MOUNTED, CANDELA AS NOTED ON PLANS, WIRED TO FACP</p> <p>▷ S- SPEAKER/STROBE, CEILING MOUNTED, CANDELA AS NOTED ON PLANS, WIRED TO FACP</p>
A1 ABBREVIATIONS	A3 LIGHTING	A5 RECEPTACLES	A7 POWER DISTRIBUTION	A9 FIRE ALARM

Scale: 12" = 1'-0"

No.	Revision	By	Date
1	ISSUED FOR BID	AEI	10/15/19
2	ADDENDUM #1	AEI	11/01/19

Designed by: CATHY FAUCHER, P.E.

By	Date	Checked	By	Date
SRM	10/15/19	CAF	CAF	10/15/19
DLL	10/15/19			

Allied Engineering
Structural Mechanical Electrical Plumbing

160 Veranda Street
Portland, Maine 04103
P: 207.221.2260
F: 207.221.2266
Web: www.allied-eng.com

STATE OF MAINE
CATHERINE A. FAUCHER
No. 7575
LICENSED PROFESSIONAL ENGINEER

MAINE TURNPIKE

THE GOLD STAR MEMORIAL HIGHWAY

MTA PROJECT MANAGER: Brian A. Taddeo, P.E.

CONTRACT 2019.12, NEW MECHANICS GARAGE LITCHFIELD MAINTENANCE YARD, MILE MARKER 92.7

ELECTRICAL ABBREVIATIONS AND LEGENDS

SHEET NUMBER: E-000

CONTRACT: 2019.12 34 OF 41

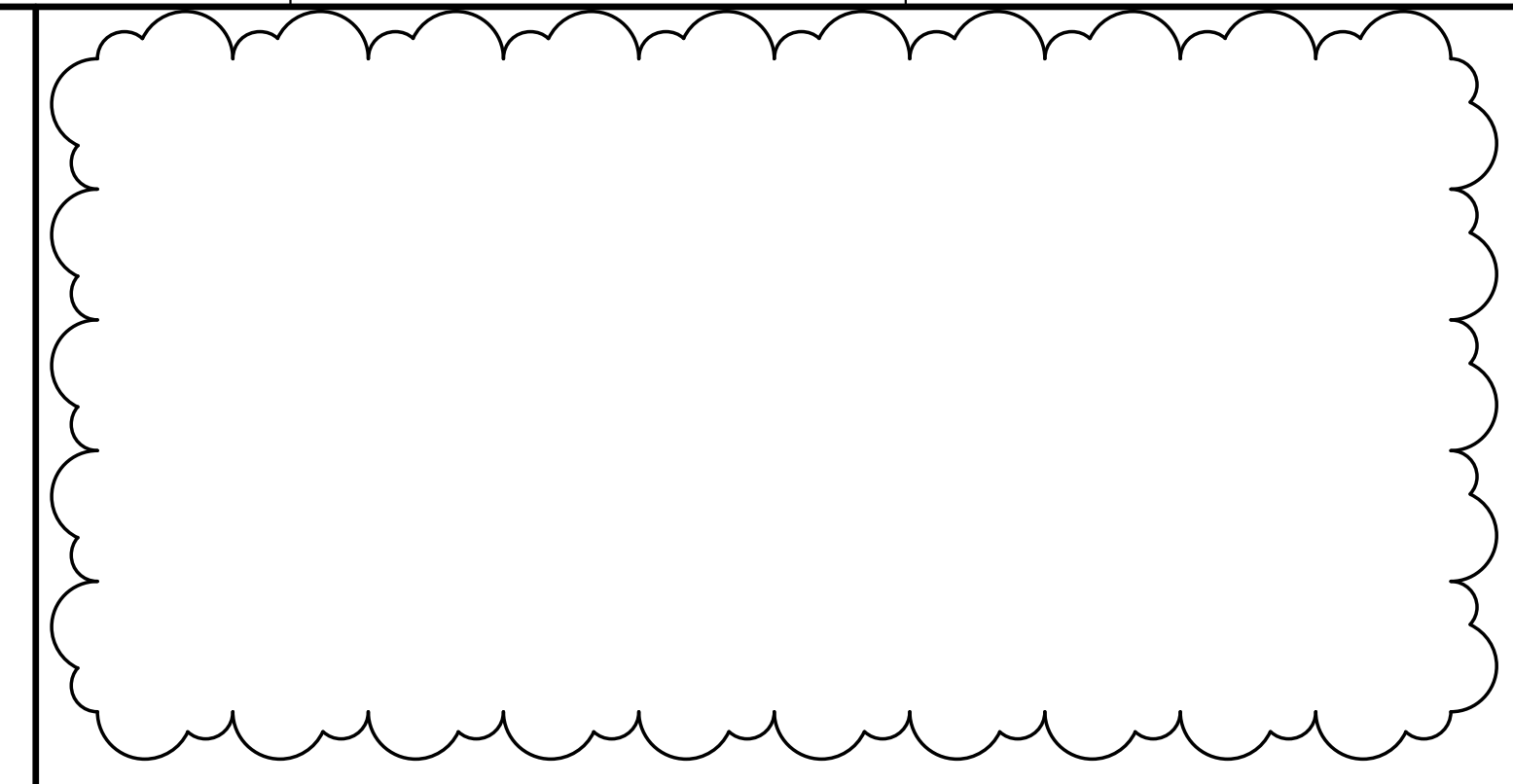
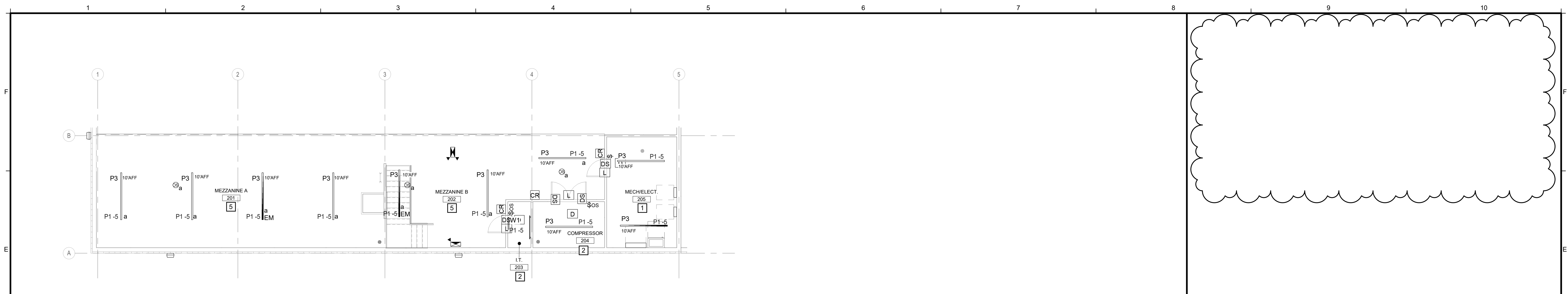

E1 LIGHTING PLAN - MEZZANINE 1/8" = 1'-0" E8 LIGHTING KEYNOTES

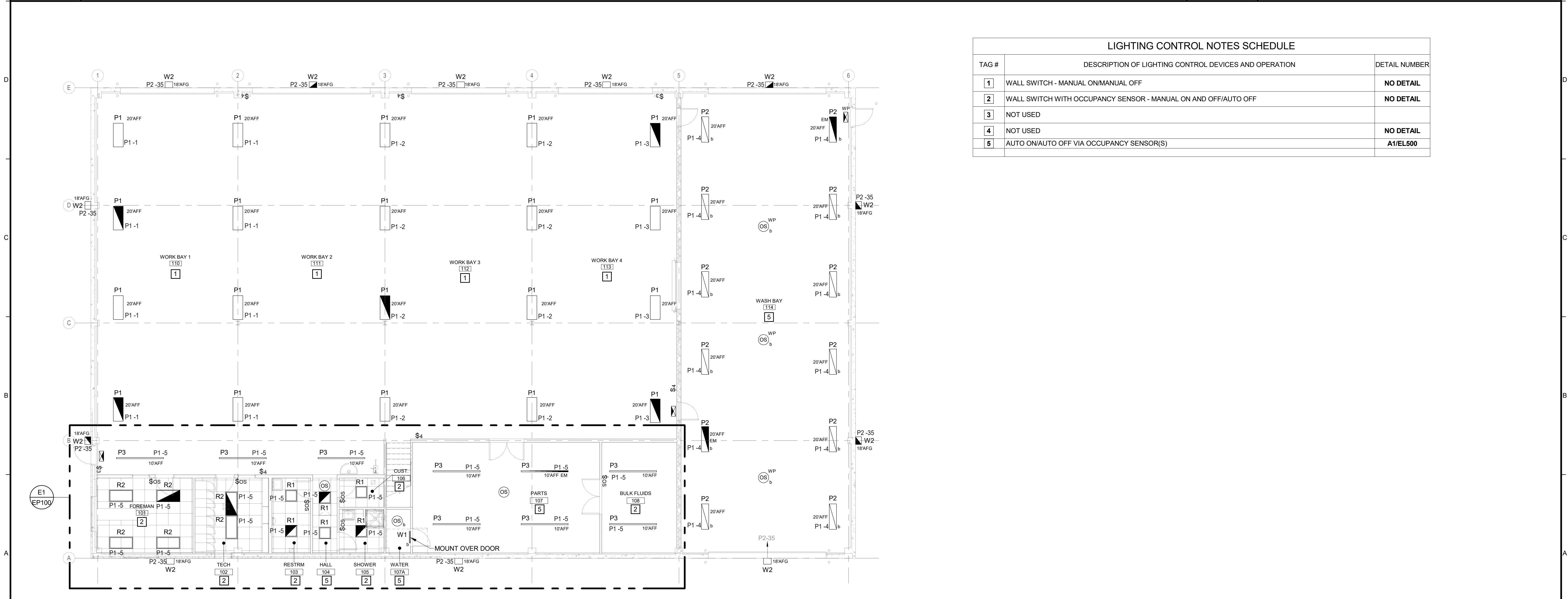

LIGHTING CONTROL NOTES SCHEDULE		
TAG #	DESCRIPTION OF LIGHTING CONTROL DEVICES AND OPERATION	DETAIL NUMBER
1	WALL SWITCH - MANUAL ON/MANUAL OFF	NO DETAIL
2	WALL SWITCH WITH OCCUPANCY SENSOR - MANUAL ON AND OFF/AUTO OFF	NO DETAIL
3	NOT USED	
4	NOT USED	NO DETAIL
5	AUTO ON/AUTO OFF VIA OCCUPANCY SENSOR(S)	A1/EL500

A1 LIGHTING PLAN - FIRST FLOOR 1/8" = 1'-0"

Scale: 1/8" = 1'-0"

No.	Revision	By	Date
1	ISSUED FOR BID	AEI	10/15/19
2	ADDENDUM #1	AEI	11/01/19

Designed by:
CATHY FAUCHER, P.E.

Designed:	By	Date	Checked:	By	Date
	SRM	10/15/19		CAF	10/15/19
Drawn:	PMC	10/15/19			

Allied Engineering
Structural Mechanical Electrical Plumbing
160 Veranda Street
Portland, Maine 04103
P: 207.221.2260
F: 207.221.2266
Web: www.allied-eng.com

**THE GOLD STAR
MEMORIAL HIGHWAY**

MTA PROJECT MANAGER: Brian A. Taddeo, P.E.

CONTRACT 2019.12, NEW MECHANICS GARAGE
LITCHFIELD MAINTENANCE YARD, MILE MARKER 92.7
LIGHTING PLAN

SHEET NUMBER: EL-100
CONTRACT: 2019.12
36 OF 41

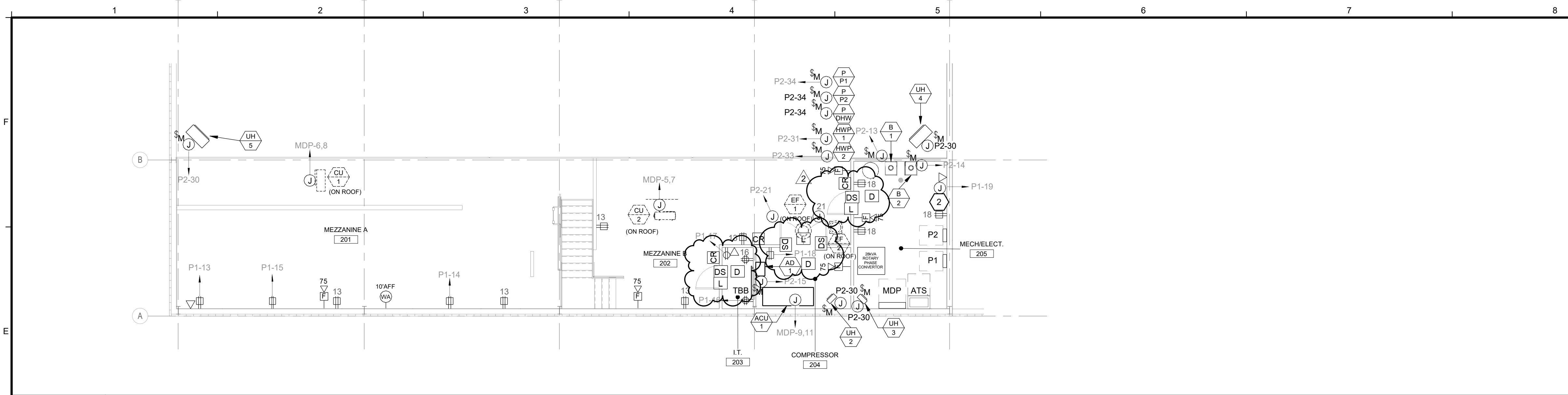

- 1 PROVIDE SINGLE GANG J-BOX FOR CONTROLS 44" AFF AND 1-1/2" CONDUIT TO DOOR OPERATOR. CONTROLS AND CONTROL WIRING BY OTHERS.
- 2 HVAC CONTROLS CIRCUIT. PROVIDE J-BOX 44" AFF.
- 3 2 POST LIFT- 2POLE DISCONNECT 30A/30A, WIRING SHALL BE 2 #10, 1 #10G

E1 POWER PLAN - MEZZANINE
1/8" = 1'-0"

E8 ELECTRICAL KEYNOTES

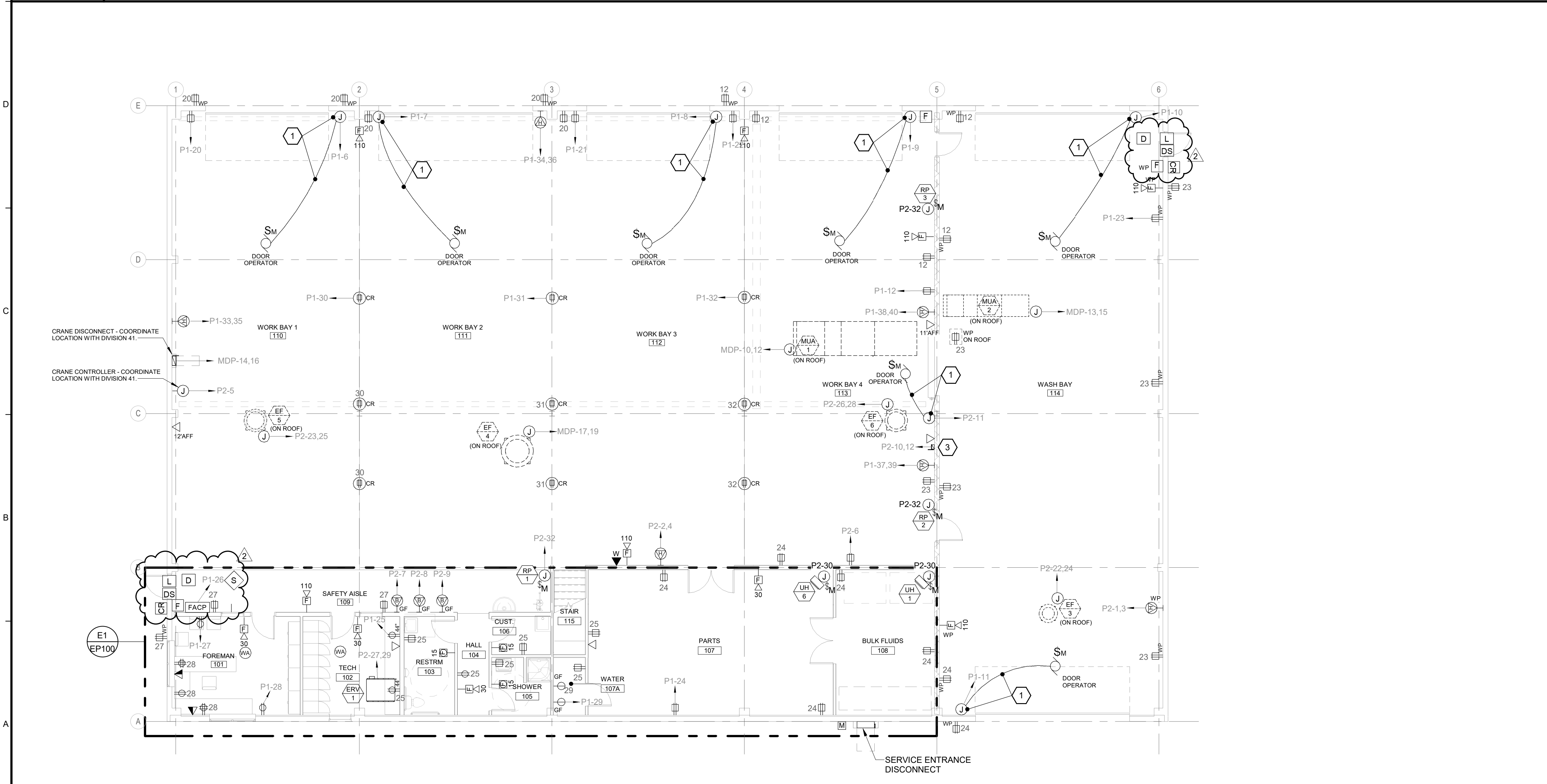

A1 POWER AND SYSTEMS PLAN - FIRST FLOOR
1/8" = 1'-0"

Scale: 1/8" = 1'-0"

No.	Revision	By	Date
1	ISSUED FOR BID	AEI	10/15/19
2	ADDENDUM #1	AEI	11/01/19

Designed by:
CATHY FAUCHER, P.E.

By	Date	Checked	By	Date
SRM	10/15/19	CAF	CAF	10/15/19
PMC	10/15/19			

STATE OF MAINE
CATHERINE A. FAUCHER
No. 7575
LICENSED PROFESSIONAL ENGINEER

Allied Engineering
Structural Mechanical Electrical Plumbing
160 Veranda Street
Portland, Maine 04103
P: 207.221.2260
F: 207.221.2266
Web: www.allied-eng.com

MAINE TURNPIKE

THE GOLD STAR MEMORIAL HIGHWAY

MTA PROJECT MANAGER: Brian A. Taddeo, P.E.

CONTRACT 2019.12, NEW MECHANICS GARAGE
LITCHFIELD MAINTENANCE YARD, MILE MARKER 92.7
POWER AND SYSTEMS PLANS

SHEET NUMBER: EP-100
CONTRACT: 2019.12
38 OF 41

MDP

Location: **Volts:** 120/240 Single
Supply From: **Phases:** 1
Mounting: Surface **Wires:** 3
A.I.C. Rating: 30kA
Mains Type: MLO
Bus Rating: 800 A
MCB Rating: 800A

Notes:

CKT	Circuit Description	Trip Amps	Poles	A (kVA)	B (kVA)	Poles	Trip Amps	Circuit Description	CKT
1	P1 PANEL	225	2	24.6	21.8		225	P2 PANEL	2
3					25.6	20.7			4
5	HVAC-CU-2	20	2	1.3	2.1		20	HVAC-CU-1	6
7				1.3	2.1				8
9	HVAC-CU-1	30	2	4.8	4.8		100	HVAC-MAU-1	10
11				4.8	4.8				12
13	HVAC-MUA-2	40	2	2.0	13.5		150	CRANE	14
15				2.0	13.5				16
17	HVAC - EF-4	40	2	3.4	0.0		40	WELDER PUMP CONTROLLER SIZE AND BREAKER SIZING	18
19				3.4	0.0				20
21	Spare	100	2	0.0	0.0		20	Spare	22
23				0.0	0.0				24
25	Spare	20	1	0.0	0.0		20	Spare	26
27				0.0	0.0				28
29	Spare	20	1	0.0	0.0		1	Spare	30
31				0.0	0.0				32
33	Spare	20	1	0.0	0.0		1	Spare	34
35				0.0	0.0		1	Spare	36
37	Spare	20	1	0.0	0.0		1	Spare	38
39				0.0	0.0		1	Spare	40
41	Spare	20	1	0.0				Spare	42

Total Load: 78.2 kW
Total Amp: 652 A

Estimated Demand: 78.1 kW
Total Amp: 651 A

Load Classification	Connected Load	Demand Factor	Estimated Demand	Panel Totals
HVAC	61076 VA	100.00%	61076 VA	
Lighting	6973 VA	125.00%	8716 VA	Total Conn. Load: 156.4 kW
Power	42106 VA	100.00%	42106 VA	Total Est. Demand: 140.2 kW
Receptacle	45780 VA	60.92%	27890 VA	Total Conn.: 652 A
				Total Est. Demand: 584 A

P1

Location: **Volts:** 120/240 Single
Supply From: MDP
Mounting: Surface
Phases: 1
Wires: 3
A.I.C. Rating: 30kA
Mains Type: MLO
Bus Rating: 225 A
MCB Rating: 225 A

Notes:

CKT	Circuit Description	Trip Amps	Poles	A	B	Circuit Description	CKT	
1	LTG-GARAGE BAY 8 FIXTURES	20	1	1.7	0.0	LTG-GARAGE BAY 8 FIXTURES	2	
3	LTG-GARAGE BAY 4 FIXTURES	20	1		0.8	LTG-WASH BAY	4	
5	LTG-101-108,201-205	20	1	0.8	0.0	DOOR OPERATOR	6	
7	DOOR OPERATOR	20	1		1.2	DOOR OPERATOR	8	
9	DOOR OPERATOR	20	1	1.2	0.0	DOOR OPERATOR	10	
11	DOOR OPERATOR	20	1		1.2	DOOR OPERATOR	12	
13	RECEPTACLE-MEZZANINE	20	1	1.1	0.0	RECEPTACLE-MEZZANINE	14	
15	RECEPTACLE-MEZZANINE	20	1		1.0	RECEPTACLE-IT 203	16	
17	DDC CONTROLLER POWER	20	1	0.2	0.0	RECEPTACLE	18	
19	Power-HVAC Controls	20	1		0.5	RECEPTACLE	20	
21	RECEPTACLE	20	1	1.0	0.0	RECEPTACLE	22	
23	RECEPTACLE	20	1		1.3	RECEPTACLE	24	
25	RECEPTACLE	20	1	1.4	0.0	Fire Alarm Control Panel	26	
27	RECEPTACLE	20	1		0.7	RECEPTACLE	28	
29	WATER PROCESSING RECEP	20	1	0.4	0.0	CORD REELS	30	
31	CORD REELS	20	1		0.5	Power Space 4	32	
33				2.4	2.4			34
35	WELDER	50	2			WELDER	36	
37				2.4	2.4			38
39	WELDER	50	2			WELDER	40	
41	DOOR LOCKS	20	1	0.0	0.0	Spare	42	
43	Spare	20	1		0.0	Spare	44	
45	Spare	20	1	0.0	0.0	Spare	46	
47	Spare	20	1		0.0	Spare	48	
49	Spare	20	1	0.0	0.0	Spare	50	
51	Spare	20	1		0.0	Spare	52	
53	Spare	20	1	0.0		Spare	54	

Total Load: 24.6 kW
Total Amp: 205 A

Estimated Demand: 25.6 kW
Total Amp: 213 A

Load Classification	Connected Load	Demand Factor	Estimated Demand	Panel Totals
Lighting	6210 VA	125.00%	7762 VA	
Power	9320 VA	100.00%	9320 VA	Total Conn. Load: 50.2 kW
Receptacle	34200 VA	64.62%	22100 VA	Total Est. Demand: 39.6 kW
				Total Conn.: 209 A
				Total Est. Demand: 165 A

ELECTRICAL SCHEDULE OF MECHANICAL EQUIPMENT- REFER TO PANEL SCHEDULES FOR CIRCUITING

TAG	DESCRIPTION/ AREA SERVED	VOLTS	PH	LOAD	FLA	MCA	MOPD	DISCONNECT SWITCH				STARTER...		WIRING IN CONDUIT (2 #12, 1#12 G UNO)	NOTES			
								FRAME	POLES	FUSE	NEMA ENCL	FBD	SIZE/ VFD			FBD	CBD	
ACU-1	AIR COMPRESSOR	230	1	7.5 HP	40		-							23	23	23	2 #8, 1 # 10G	
AD-1	AIR DRYER	230	1	7.5 HP	40		-							23	23	23	2 #8, 1 # 10G	
B-1	BOILER	120	1	40W										23	23	23		
B-2	BOILER	120	1											23	23	23		
CU-1	CONDENSING UNIT OUTDOOR	240	1		17.2	20	30	2	15	3R				23	23	23	2 #10, 1 #10G	3
CU-2	CONDENSING UNIT OUTDOOR	240	1		11	14	20							26	23	23		3
EF-1	FAN	120	1	1/4 HP	5.8									23	23	23		
EF-2	FAN	120	1	1/10 HP	2									23	23	23		
EF-3	FAN	240	1	2 HP	12									23	23	23		
EF-4	FAN	240	1	5 HP	28			40						23	23	23	2 #8, 1 #10G	4,9
EF-5	FAN	240	1	2 HP	12									23	23	23		
EF-6	FAN	240	1	2 HP	12									23	23	23		
ERV-1	ENERGY RECOVERY UNIT	240	1		4	5	15							23	23	23		
MUA-1	MAKE UP AIR UNIT	240	1	7 HP	40		100							23	23	23	2 #2, 1 #8G	4,9
MUA-2	MAKE UP AIR UNIT	240	1	3 HP	17		40							23	23	23	2 #8, 1 # 10G	4,8
P-P1	BOILER PRIMARY PUMP	120	1	1/6	2.2									26		23		1
P-P2	BOILER PRIMARY PUMP	120	1	1/6	2.2									26		23		1
HWP-1	HEATING SECONDARY PUMP	120	1	347W	2.9									26		23		1
HWP-2	HEATING SECONDARY PUMP	120	1	347W	2.9									26		23		1
P-DHW	INDIRECT WATER HEATER PUMP	120	1	179W	1.5									26		23		
RP-1	RADIANT MF 1 PUMP-WORK BAY	120	1	73W	0.6									26		23		
RP-2	RADIANT MF 2 PUMP-WORK BAY	120	1	73W	0.6									26		23		
RP-3	RADIANT MF 3 PUMP-WASH BAY	120	1	73W	0.6									26		23		
UH-1	UNIT HEATER	120	1	16W	0.14									23		23		
UH-2	UNIT HEATER	120	1	16W	0.14									23		23		
UH-3	UNIT HEATER	120	1	16W	0.14									23		23		
UH-4	UNIT HEATER	120	1	1/12 HP	1									23		23		
UH-5	UNIT HEATER	120	1	1/12 HP	1									23		23		
UH-6	UNIT HEATER	120	1	16W	0.14									23		23		

NOTES:

- LEAD/LAG
- DUCT SMOKE DETECTORS FURNISHED BY DIVISION 26. INSTALLED BY DIVISION 23. WIRED TO FIRE ALARM BY DIVISION 26.
- POWER TO CU BY DIVISION 26. WIRING BETWEEN AC AND CU PROVIDED BY DIVISION 23
- 1 PHASE TO 3 PHASE CONVERTER VFD FURNISHED AND INSTALLED BY DIV 23. WIRED AND CONNECTED BY DIV 26
- UNIT IS CONSISTS OF MULTIPLE MOTORS FACTORY WIRED FOR SINGLE-POINT POWER CONNECTION.
- REFER TO DETAIL DISHEET EP2.1 FOR WIRING AND DEVICE REQUIREMENTS.
- CORD AND PLUG CONNECTION. PROVIDE NEMA 5-20 SINGLE GFI WEATHERPOOF RECEPTACLE.
- PROVIDE 3 #12, 1# 12G FROM 3 PHASE CONVERTER VFD TO HVAC EQUIPMENT
- PROVIDE 3 #10, 1# 10G FROM 3 PHASE CONVERTER VFD TO HVAC EQUIPMENT

ABBREVIATIONS:

FWE FURNISHED WITH EQUIPMENT
NF NOT FUSED
SWBD SWITCHBOARD
FBD FURNISHED BY DIVISION
CBD CONTROL WIRING BY DIVISION

P2

Location: MECH/ELECT. 205
Supply From: MDP
Mounting: Surface
Volts: 120/240 Single
Phases: 1
Wires: 3
A.I.C. Rating: 30kA
Mains Type: MLO
Bus Rating: 225 A
MCB Rating: 225 A

Notes:

CKT	Circuit Description	Trip Amps	Poles	A	B	Circuit Description	CKT	
1	PRESSURE WASHER	50	2	2.4	2.4	WELDER	2	
3					2.4	2.4	WELDER	4
5	CRANE CONTROLLER	20	1	0.2	0.0	RECEPTACLE	6	
7	RECEPTACLE	20	1		0.6	RECEPTACLE	8	
9	RECEPTACLE	20	1	0.6	0.0		10	
11	DOOR OPERATOR	20	1		1.2	2 POST LIFT	12	
13	HVAC-BOILER 1	20	1	0.5	0.0	HVAC-BOILER 2	14	
15	HVAC-AD-1	20	1		0.0	HVAC - BOOSTER PUMPS	16	
17	HVAC - SUMP PUMP	20	1	1.0	0.0	HVAC - SEPTIC PUMP	18	
19	Power - SUM PIT RECEPT/LGT	20	1		0.5		20	
21	HVAC - EF 1/EF2	20	1	0.9	1.4	HVAC - EF 3	22	
23					1.4	1.4		24
25	HVAC - EF-5	20	2	1.4	0.6	HVAC - EF-6	26	
27					0.6	1.4		28
29	HVAC - ERV-1	20	2	0.6	0.0	HVAC - UNIT HEATERS 1-6	30	
31	HVAC - HWP-1	20	1		0.4	0.2	HVAC - PUMPS RP1,RP2,RP3	32
33	HVAC - HWP-2	20	1	0.4	0.0	HVAC - PUMPS P1,P2,DHW	34	
35	Lighting - EXTERIOR WALL LIGHTING	20	1		0.8	0.5	GENERATOR - STRIP HEATER	36
37	GENERATOR - JACKET HEATER	20	1	0.5	0.0	GENERATOR - BATTERY CHARGER	38	
39	Spare	20	1		0.0	0.0	Spare	40
41	Spare	20	1	0.0			Spare	42

Total Load: 21.8 kW
Total Amp: 181 A

Estimated Demand: 20.7 kW
Total Amp: 173 A

Load Classification	Connected Load	Demand Factor	Estimated Demand	Panel Totals
HVAC	24308 VA	100.00%	24308 VA	
Lighting	804 VA	125.00%	1005 VA	Total Conn. Load: 42.5 kW
Power	5840 VA	100.00%	5840 VA	Total Est. Demand: 41.8 kW
Receptacle	11580 VA	93.18%	10790 VA	Total Conn.: 177 A
				Total Est. Demand: 174 A

Scale:

No.	Revision	By	Date
1	ISSUED FOR BID	AEI	10/15/19
2	ADDENDUM #1	AEI	11/01/19

Designed by:
CATHY FAUCHER, P.E.

Designed: SRM 10/15/19
Checked: CAF 10/15/19
Drawn: PMC 10/15/19

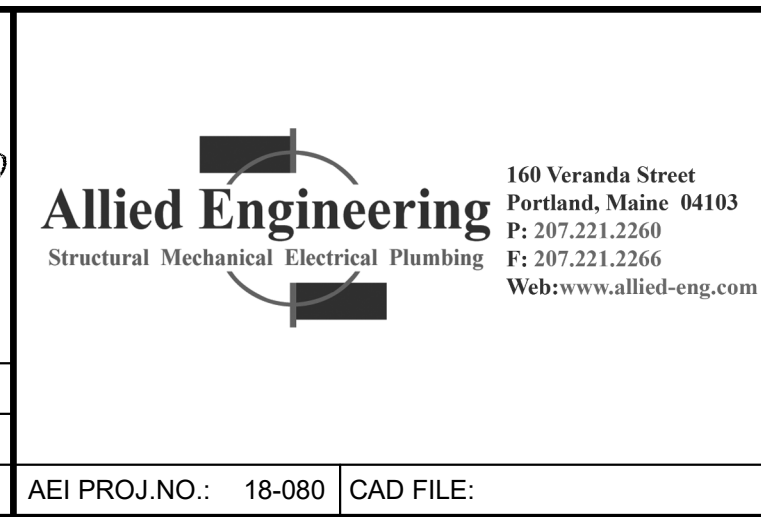

Allied Engineering
Structural Mechanical Electrical Plumbing
160 Veranda Street
Portland, Maine 04103
P: 207.221.2260
F: 207.221.2266
Web: www.allied-eng.com

MAINE TURNPIKE

THE GOLD STAR MEMORIAL HIGHWAY

MTA PROJECT MANAGER: Brian A. Taddeo, P.E.

CONTRACT 2019.12, NEW MECHANICS GARAGE LITCHFIELD MAINTENANCE YARD, MILE MARKER 92.7 ELECTRICAL SCHEDULES

SHEET NUMBER: EP-600

CONTRACT: 2019.12
40 OF 41

SECTION 012100 - ALLOWANCES

PART 1 - GENERAL

1.1 RELATED DOCUMENTS

- A. If the Contractor discovers any ambiguity, error, omission, conflict, or discrepancy, General Conditions Section 101.3.6 Priority of Conflicting Contract Documents shall control.
 - 1. Drawings and general provisions of the Contract, including General and Supplementary Conditions and other Division 1 Specification Sections, apply to this Section.
 - 2. State of Maine Department of Transportation, "Standard Specifications," Revision December 2014, and any revisions thereto, apply to this Section.
 - 3. Any supplements to any of the above specifications and or standards issued prior to issuance of this specification, apply to this section.

1.2 SUMMARY

- A. Section includes administrative and procedural requirements governing allowances.
 - 1. Certain items are specified in the Contract Documents by allowances. Allowances have been established in lieu of additional requirements and to defer selection of actual materials and equipment to a later date when direction will be provided to the Contractor. If necessary, additional requirements will be issued by Change Order.
- B. Types of allowances include the following:
 - 1. Contingency allowances.
- C. Related Requirements:
 - 1. Section 260100 – "Basic Electrical Requirements" for procedures for using unit prices, including adjustment for procedures governing the use of allowances for field testing by an independent testing agency.

1.3 DEFINITIONS

- A. Allowance: A quantity of work or dollar amount included in the Contract, established in lieu of additional requirements, used to defer selection of actual materials and equipment to a later date when direction will be provided to Contractor. If necessary, additional requirements will be issued by Change Order.

1.4 SELECTION AND PURCHASE

- A. At the earliest practical date after award of the Contract, advise Architect of the date when final Work described by an allowance must be completed to avoid delaying the Work.

1.5 SUBMITTALS

- A. Submit proposals for purchase of products or systems included in allowances, in the form specified for Change Orders.
- B. Submit invoices or delivery slips to show actual quantities of materials delivered to the site for use in fulfillment of each allowance.
- C. Submit time sheets and other documentation to show labor time and cost for installation of allowance items that include installation as part of the allowance.
- D. Coordinate and process submittals for allowance items in same manner as for other portions of the Work.

1.6 CONTINGENCY ALLOWANCES

- A. Use the contingency allowance only as directed by Architect for Owner's purposes and only by Change Orders that indicate amounts to be charged to the allowance.
- B. Contractor's related costs for products and equipment ordered by Owner under the contingency allowance are included in the allowance and are not part of the Contract Sum. These costs include delivery, installation[, taxes], insurance, equipment rental, and similar costs.
- C. Change Orders authorizing use of funds from the contingency allowance will include Contractor's related costs and reasonable overhead and profit.
- D. At Project closeout, credit unused amounts remaining in the contingency allowance to Owner by Change Order.

1.7 COORDINATION

- A. Coordinate allowance items with other portions of the Work. Furnish templates as required to coordinate installation.

1.8 ADJUSTMENT OF ALLOWANCES

- A. Allowance Adjustment: To adjust allowance amounts, prepare a Change Order proposal based on the difference between purchase amount and the allowance, multiplied by final measurement of work-in-place where applicable. If applicable, include reasonable allowances for cutting losses, tolerances, mixing wastes, normal product imperfections, and similar margins.
 - 1. Submit substantiation of a change in scope of work, if any, claimed in Change Orders related to unit-cost allowances.
 - 2. Owner reserves the right to establish the quantity of work-in-place by independent quantity survey, measure, or count.
 - 3. Do not include Contractor's or subcontractor's indirect expense in the Change Order cost amount unless it is clearly shown that the nature or extent of work has changed from what could have been foreseen from information in the Contract Documents.

- B. Submit claims for increased costs due to a change in the scope or nature of the allowance described in the Contract Documents, whether for the purchase order amount or Contractor's handling, labor, installation, overhead, and profit.
 - 1. Do not include Contractor's or subcontractor's indirect expense in the Change Order cost amount unless it is clearly shown that the nature or extent of Work has changed from what could have been foreseen from information in the Contract Documents.
 - 2. No change to Contractor's indirect expense is permitted for selection of higher- or lower-priced materials or systems of the same scope and nature as originally indicated.

PART 2 - PRODUCTS (Not Used)

PART 3 - EXECUTION

3.1 EXAMINATION

- A. Examine products covered by an allowance promptly on delivery for damage or defects. Return damaged or defective products to manufacturer for replacement.

3.2 PREPARATION

- A. Coordinate materials and their installation for each allowance with related materials and installations to ensure that each allowance item is completely integrated and interfaced with related work.

3.3 SCHEDULE OF ALLOWANCES

- A. Allowance No. 1 - \$50,000: Carry in the base bid Central Maine Power Company utility construction charges for electrical services as specified in Division 26 Section "Basic Electrical Requirements."

END OF SECTION 012100

SECTION 077200 - ROOF ACCESSORIES

PART 1 - GENERAL

1.1 RELATED DOCUMENTS

- A. Drawings and general provisions of the Contract, including General and Supplementary Conditions and Division 01 Specification Sections, apply to this Section.

1.2 SUMMARY

- A. Section Includes:

- 1. Roof curbs.
- 2. Equipment supports.
- 3. Roof hatches.
- 4. Roof-edge specialties

- B. Related Sections:

- 1. Section 055000 "Metal Fabrications" for metal vertical ladders for access to roof hatch.
- 2. Section 076200 "Sheet Metal Flashing and Trim" for shop and field-formed metal flashing and miscellaneous sheet metal trim and accessories.

1.3 COORDINATION

- A. Coordinate layout and installation of roof accessories with roofing membrane and base flashing and interfacing and adjoining construction to provide a leakproof, weathertight, secure, and noncorrosive installation.
- B. Coordinate dimensions with rough-in information or Shop Drawings of equipment to be supported.

1.4 ACTION SUBMITTALS

- A. Product Data: For each type of roof accessory.

- 1. Include construction details, material descriptions, dimensions of individual components and profiles, and finishes.

- B. Shop Drawings: For roof accessories.

- 1. Include plans, elevations, keyed details, and attachments to other work. Indicate dimensions, loadings, and special conditions. Distinguish between plant- and field-assembled work.

- C. Samples: For each exposed product and for each color and texture specified, prepared on Samples of size to adequately show color.
- D. Delegated-Design Submittal: For equipment supports indicated to comply with performance requirements and design criteria, including analysis data signed and sealed by the qualified professional engineer responsible for their preparation.
 - 1. Detail mounting, securing, and flashing of roof-mounted items to roof structure. Indicate coordinating requirements with roof membrane system.

1.5 INFORMATIONAL SUBMITTALS

- A. Coordination Drawings: Roof plans, drawn to scale, and coordinating penetrations and roof-mounted items. Show the following:
 - 1. Size and location of roof accessories specified in this Section.
 - 2. Method of attaching roof accessories to roof or building structure.
 - 3. Required clearances.
- B. Sample Warranties: For manufacturer's special warranties.

1.6 CLOSEOUT SUBMITTALS

- A. Operation and Maintenance Data: For roof accessories to include in operation and maintenance manuals.

PART 2 - PRODUCTS

2.1 PERFORMANCE REQUIREMENTS

- A. General Performance: Roof accessories shall withstand exposure to weather and resist thermally induced movement without failure, rattling, leaking, or fastener disengagement due to defective manufacture, fabrication, installation, or other defects in construction.

2.2 ROOF CURBS

- A. Roof Curbs: Internally reinforced roof-curb units capable of supporting superimposed live and dead loads, including equipment loads and other construction indicated on Drawings, bearing continuously on roof structure, and capable of meeting performance requirements; with welded or mechanically fastened and sealed corner joints, straight sides, and integrally formed deck-mounting flange at perimeter bottom.
 - 1. Manufacturers: Subject to compliance with requirements, provide products by one of the following:
 - a. Adaptable Air Products.
 - b. AES Industries, Inc.

- c. Air Balance; a division of MESTEK, Inc.
- d. Conn-Fab Sales, Inc.
- e. Curbs Plus, Inc.
- f. Custom Solution Roof and Metal Products.
- g. Greenheck Fan Corporation.
- h. KCC International Inc.
- i. Kingspan Light + Air, North America.
- j. Lloyd Industries, Inc.
- k. LMCurbs.
- l. Louvers & Dampers, Inc.; a division of Mestek, Inc.
- m. Metallic Products Corp.
- n. Milcor; Commercial Products Group of Hart & Cooley, Inc.
- o. Pate Company (The).
- p. Plenums Incorporated.
- q. Roof Curb Systems.
- r. Roof Products and Systems (RPS); a division of Hart & Cooley, Inc.
- s. Roof Products, Inc.
- t. Sunoptics Skylights and Daylighting Systems; Acuity Brands International, Inc.
- u. Thybar Corporation.
- v. Vent Products Co., Inc.

- B. Size: Coordinate dimensions with roughing-in information or Shop Drawings of equipment to be supported.
- C. Supported Load Capacity: As indicated by the equipment manufacturer.
- D. Material: Zinc-coated (galvanized) steel sheet, 0.064 inch thick.
- E. Construction:
 - 1. Curb Profile: Manufacturer's standard compatible with roofing system.
 - 2. On ribbed or fluted metal roofs, form deck-mounting flange at perimeter bottom to conform to roof profile.
 - 3. Fabricate curbs to minimum height of 12 inches above roofing surface unless otherwise indicated.
 - 4. Top Surface: Level top of curb, with roof slope accommodated by sloping deck-mounting flange or by use of leveler frame.
 - 5. Sloping Roofs: Where roof slope exceeds 1:48, fabricate curb with perimeter curb height tapered to accommodate roof slope so that top surface of perimeter curb is level. Equip unit with water diverter or cricket on side that obstructs water flow.
 - 6. Insulation: Factory insulated with 1-1/2-inch- thick glass-fiber board insulation.
 - 7. Liner: Same material as curb, of manufacturer's standard thickness and finish.
 - 8. Wind Restraint Straps and Base Flange Attachment: Provide wind restraint straps, welded strap connectors, and base flange attachment to roof structure at perimeter of curb, of size and spacing required to meet wind uplift requirements.
 - 9. Platform Cap: Where portion of roof curb is not covered by equipment, provide weathertight platform cap formed from 3/4-inch thick plywood covered with metal sheet of same type, thickness, and finish as required for curb.
 - 10. Metal Counterflashing: Manufacturer's standard, removable, fabricated of same metal and finish as curb.

2.3 ROOF HATCH

- A. Roof Hatches: Metal roof-hatch units with lids and insulated double-walled curbs, welded or mechanically fastened and sealed corner joints, continuous lid-to-curb counterflashing and weathertight perimeter gasketing, straight sides, and integrally formed deck-mounting flange at perimeter bottom.
1. Manufacturers: Subject to compliance with requirements, provide products by one of the following:
 - a. Acudor Products, Inc.
 - b. AES Industries, Inc.
 - c. Architectural Specialties, Inc.
 - d. Babcock-Davis.
 - e. BILCO Company (The).
 - f. Custom Solution Roof and Metal Products.
 - g. Dur-Red Products.
 - h. Hi Pro International, Inc.
 - i. JL Industries, Inc.; a division of the Activar Construction Products Group.
 - j. KCC International Inc.
 - k. Kingspan Light + Air, North America.
 - l. Lexcor; a division of Luxsuco corp.
 - m. Metallic Products Corp.
 - n. Milcor; Commercial Products Group of Hart & Cooley, Inc.
 - o. Nystrom.
 - p. O'Keeffe's Inc.
 - q. Pate Company (The).
 - r. Williams Bros. Corporation of America (The).
- B. Type and Size: Single-leaf lid, 30 by 36 inches.
- C. Loads: Minimum 40-lbf/sq. ft. external live load and 20-lbf/sq. ft. internal uplift load.
- D. Hatch Material: Aluminum-zinc alloy-coated steel sheet.
1. Thickness: Manufacturer's standard thickness for hatch size indicated.
 2. Finish: Mill phosphatized.
- E. Construction:
1. Insulation: Polyisocyanurate board.
 - a. R-Value: 12.0 according to ASTM C 1363.
 2. Nailer: Factory-installed wood nailer continuous around hatch perimeter.
 3. Hatch Lid: Opaque, insulated, and double walled, with manufacturer's standard metal liner of same material and finish as outer metal lid.
 4. Curb Liner: Manufacturer's standard, of same material and finish as metal curb.
 5. On ribbed or fluted metal roofs, form flange at perimeter bottom to conform to roof profile.

6. Fabricate curbs to minimum height of 12 inches above roofing surface unless otherwise indicated.
- F. Hardware: Spring operators, hold-open arm, stainless-steel spring latch with turn handles, stainless-steel butt- or pintle-type hinge system, and padlock hasps inside and outside.
- G. Roof-Edge Fascia: Manufactured, two-piece, roof-edge fascia consisting of snap-on metal fascia cover in section lengths and a continuous metal receiver with integral drip-edge cleat to engage fascia cover **and secure single-ply roof membrane**. Provide matching corner units.
1. Metallic-Coated Steel Sheet Fascia Covers: Zinc-coated (galvanized) steel, nominal **thickness as required to meet performance requirements**.
 - a. Surface: **Smooth, flat** finish.
 - b. Finish: **Three-coat fluoropolymer**.
 - c. Color: **As selected by Architect from manufacturer's full range**.
 2. Corners: Factory mitered and **mechanically clinched and sealed watertight**.
 3. Splice Plates: **Concealed**, of same material, finish, and shape as fascia cover.
 4. Receiver: **Galvanized-steel sheet, Manufacturer's standard material and thickness**.
 5. Fascia Accessories: **Fascia extenders with continuous hold-down cleats, Overflow scuppers**.

2.4 METAL MATERIALS

- A. Zinc-Coated (Galvanized) Steel Sheet: ASTM A 653/A 653M, G90 coating designation and mill phosphatized for field painting where indicated.
1. Mill-Phosphatized Finish: Manufacturer's standard for field painting.
- B. Aluminum Sheet: ASTM B 209, manufacturer's standard alloy for finish required, with temper to suit forming operations and performance required.
1. Mill Finish: As manufactured.
- C. Aluminum Extrusions and Tubes: ASTM B 221, manufacturer's standard alloy and temper for type of use, finished to match assembly where used; otherwise mill finished.
- D. Steel Shapes: ASTM A 36/A 36M, hot-dip galvanized according to ASTM A 123/A 123M unless otherwise indicated.

2.5 MISCELLANEOUS MATERIALS

- A. General: Provide materials and types of fasteners, protective coatings, sealants, and other miscellaneous items required by manufacturer for a complete installation.
- B. Cellulosic-Fiber Board Insulation: ASTM C 208, Type II, Grade 1, thickness as indicated.

- C. Glass-Fiber Board Insulation: ASTM C 726, nominal density of 3 lb/cu. ft., thermal resistivity of 4.3 deg F x h x sq. ft./Btu x in. at 75 deg F, thickness as indicated.
- D. Polyisocyanurate Board Insulation: ASTM C 1289, thickness and thermal resistivity as indicated.
- E. Wood Nailers: Softwood lumber, pressure treated with waterborne preservatives for aboveground use, acceptable to authorities having jurisdiction, containing no arsenic or chromium, and complying with AWPA C2; not less than 1-1/2 inches thick.
- F. Bituminous Coating: Cold-applied asphalt emulsion complying with ASTM D 1187/D 1187M.
- G. Gaskets: Manufacturer's standard tubular or fingered design of neoprene, EPDM, PVC, or silicone or a flat design of foam rubber, sponge neoprene, or cork.
- H. Elastomeric Sealant: ASTM C 920, elastomeric polyurethane polymer sealant as recommended by roof accessory manufacturer for installation indicated; low modulus; of type, grade, class, and use classifications required to seal joints and remain watertight.
- I. Butyl Sealant: ASTM C 1311, single-component, solvent-release butyl rubber sealant; polyisobutylene plasticized; heavy bodied for expansion joints with limited movement.
- J. Asphalt Roofing Cement: ASTM D 4586/D 4586M, asbestos free, of consistency required for application.

2.6 GENERAL FINISH REQUIREMENTS

- A. Comply with NAAMM's "Metal Finishes Manual for Architectural and Metal Products" for recommendations for applying and designating finishes.
- B. Appearance of Finished Work: Noticeable variations in same piece are not acceptable. Variations in appearance of adjoining components are acceptable if they are within the range of approved Samples and are assembled or installed to minimize contrast.

PART 3 - EXECUTION

3.1 EXAMINATION

- A. Examine substrates, areas, and conditions, with Installer present, to verify actual locations, dimensions, and other conditions affecting performance of the Work.
- B. Verify that substrate is sound, dry, smooth, clean, sloped for drainage, and securely anchored.
- C. Verify dimensions of roof openings for roof accessories.
- D. Proceed with installation only after unsatisfactory conditions have been corrected.

3.2 INSTALLATION

- A. General: Install roof accessories according to manufacturer's written instructions.
 - 1. Install roof accessories level; plumb; true to line and elevation; and without warping, jogs in alignment, buckling, or tool marks.
 - 2. Anchor roof accessories securely in place so they are capable of resisting indicated loads.
 - 3. Use fasteners, separators, sealants, and other miscellaneous items as required to complete installation of roof accessories and fit them to substrates.
 - 4. Install roof accessories to resist exposure to weather without failing, rattling, leaking, or loosening of fasteners and seals.
- B. Metal Protection: Protect metals against galvanic action by separating dissimilar metals from contact with each other or with corrosive substrates by painting contact surfaces with bituminous coating or by other permanent separation as recommended by manufacturer.
 - 1. Bed flanges in thick coat of asphalt roofing cement where required by manufacturers of roof accessories for waterproof performance.
- C. Roof Curb Installation: Install each roof curb so top surface is level.
- D. Equipment Support Installation: Install equipment supports so top surfaces are level with each other.
- E. Roof-Hatch Installation:
 - 1. Verify that roof hatch operates properly. Clean, lubricate, and adjust operating mechanism and hardware.
- F. Preformed Flashing-Sleeve Installation: Secure flashing sleeve to roof membrane according to flashing-sleeve manufacturer's written instructions; flash sleeve flange to surrounding roof membrane according to roof membrane manufacturer's instructions.
- G. Seal joints with elastomeric or butyl sealant as required by roof accessory manufacturer.

3.3 ROOF-EDGE SPECIALITIES INSTALLATION

- A. Install cleats, cants, and other anchoring and attachment accessories and devices with concealed fasteners.
- B. Anchor roof edgings with manufacturer's required devices, fasteners, and fastener spacing to meet performance requirements.

3.4 REPAIR AND CLEANING

- A. Galvanized Surfaces: Clean field welds, bolted connections, and abraded areas and repair galvanizing according to ASTM A 780/A 780M.
- B. Clean exposed surfaces according to manufacturer's written instructions.
- C. Clean off excess sealants.

- D. Replace roof accessories that have been damaged or that cannot be successfully repaired by finish touchup or similar minor repair procedures.

END OF SECTION 077200

SECTION 083323 - OVERHEAD COILING DOORS

PART 1 - GENERAL

1.1 RELATED DOCUMENTS

- A. Drawings and general provisions of the Contract, including General and Supplementary Conditions and Division 01 Specification Sections, apply to this Section.

1.2 SUMMARY

- A. Section Includes:

- 1. Service doors.

- B. Related Requirements:

- 1. Section 055000 "Metal Fabrications" for miscellaneous steel supports, door-opening framing, corner guards, and bollards.

1.3 ACTION SUBMITTALS

- A. Product Data: For each type and size of overhead coiling door and accessory.

- 1. Include construction details, material descriptions, dimensions of individual components, profiles for slats, and finishes.
- 2. Include rated capacities, operating characteristics, electrical characteristics, and furnished accessories.
- 3. Include description of automatic-closing device and testing and resetting instructions.

- B. Shop Drawings: For each installation and for special components not dimensioned or detailed in manufacturer's product data.

- 1. Include plans, elevations, sections, and mounting details.
- 2. Include details of equipment assemblies, and indicate dimensions, required clearances, method of field assembly, components, and location and size of each field connection.
- 3. Include points of attachment and their corresponding static and dynamic loads imposed on structure.
- 4. Show locations of controls, locking devices, and other accessories.
- 5. Include diagrams for power, signal, and control wiring.

- C. Samples for Initial Selection: Manufacturer's finish charts showing full range of colors and textures available for units with factory-applied finishes.

- 1. Include similar Samples of accessories involving color selection.

1.4 INFORMATIONAL SUBMITTALS

- A. Qualification Data: For Installer.
- B. Sample Warranty: For special warranty.

1.5 CLOSEOUT SUBMITTALS

- A. Maintenance Data: For overhead coiling doors to include in maintenance manuals.

1.6 QUALITY ASSURANCE

- A. Installer Qualifications: An entity that employs installers and supervisors who are trained and approved by manufacturer for both installation and maintenance of units required for this Project.
 - 1. Maintenance Proximity: Not more than two hours' normal travel time from Installer's place of business to Project site.

1.7 WARRANTY

- A. Special Warranty: Manufacturer agrees to repair or replace components of doors that fail in materials or workmanship within specified warranty period.
 - 1. Warranty Period: Three years from date of Substantial Completion.

PART 2 - PRODUCTS

2.1 MANUFACTURERS

- A. Source Limitations: Obtain overhead coiling doors from single source from single manufacturer.
 - 1. Obtain operators and controls from overhead coiling-door manufacturer.

2.2 DOOR ASSEMBLY

- A. Insulated Service Door: Overhead coiling door formed with curtain of interlocking metal slats.
 - 1. Manufacturers: Subject to compliance with requirements, provide products by one of the following:
 - a. ACME Rolling Doors.
 - b. Alpine Overhead Doors, Inc.
 - c. Alumatec Pacific Products.
 - d. ASTA Door Corporation.

- e. C.H.I. Overhead Doors, Inc.
 - f. Clopay Building Products.
 - g. Cookson Company.
 - h. Cornell Iron Works, Inc.
 - i. Lawrence Roll-Up Doors, Inc.
 - j. McKeon Rolling Steel Door Company, Inc.
 - k. Overhead Door Corporation.
 - l. Raynor.
 - m. Southwestern Rolling Steel Door Co.
 - n. Wayne-Dalton Corp.
- B. Operation Cycles: Door components and operators capable of operating for not less than 100,000. One operation cycle is complete when a door is opened from the closed position to the fully open position and returned to the closed position.
- 1. Include tamperproof cycle counter.
- C. Air Infiltration: Maximum rate of 0.4 cfm/sq. ft. at 15 and 25 mph when tested according to ASTM E 283 or DASMA 105.
- D. STC Rating: 26.
- E. Door Curtain Material: Galvanized steel.
- F. Door Curtain Slats: Flat profile slats of 2-5/8-inch center-to-center height.
- G. Bottom Bar: Two angles, each not less than 1-1/2 by 1-1/2 by 1/8 inch thick; fabricated from hot-dip galvanized steel or aluminum extrusions and finished to match door.
- H. Curtain Jamb Guides: Galvanized steel with exposed finish matching curtain slats.
- I. Hood: Match curtain material and finish.
- 1. Shape: Round.
 - 2. Mounting: Face of wall.
- J. Electric Door Operator:
- 1. Usage Classification: Standard duty, up to 25 cycles per hour and up to 90 cycles per day.
 - 2. Operator Location: Wall.
 - 3. Safety: Listed according to UL 325 by a qualified testing agency for commercial or industrial use; moving parts of operator enclosed or guarded if exposed and mounted at 8 feet or lower.
 - 4. Motor Exposure: Interior.
 - 5. Motor Electrical Characteristics:
 - a. Horsepower: 1/2 hp.
 - b. Voltage: 115-V ac, single phase, 60 Hz.
 - c. Voltage: 208-V ac, three phase, 60 Hz.
 - 6. Emergency Manual Operation: Chain type.

7. Control Station(s): Interior mounted.
8. Other Equipment: Audible and visual signals, and Portable radio-control system.

K. Door Finish:

1. Baked-Enamel or Powder-Coated Finish: Color as selected by Architect from manufacturer's full range.

2.3 MATERIALS, GENERAL

- A. Electrical Components, Devices, and Accessories: Listed and labeled as defined in NFPA 70, by a qualified testing agency, and marked for intended location and application.

2.4 DOOR CURTAIN MATERIALS AND CONSTRUCTION

- A. Door Curtains: Fabricate overhead coiling-door curtain of interlocking metal slats, designed to withstand wind loading indicated, in a continuous length for width of door without splices. Unless otherwise indicated, provide slats of thickness and mechanical properties recommended by door manufacturer for performance, size, and type of door indicated, and as follows:

1. Steel Door Curtain Slats: Zinc-coated (galvanized), cold-rolled structural-steel sheet; complying with ASTM A 653/A 653M, with G90 zinc coating; nominal sheet thickness (coated) of 0.028 inch; and as required.

- B. Curtain Jamb Guides: Manufacturer's standard angles or channels and angles of same material and finish as curtain slats unless otherwise indicated, with sufficient depth and strength to retain curtain, to allow curtain to operate smoothly, and to withstand loading. Slot bolt holes for guide adjustment. Provide removable stops on guides to prevent overtravel of curtain.

2.5 HOODS

- A. General: Form sheet metal hood to entirely enclose coiled curtain and operating mechanism at opening head. Contour to fit end brackets to which hood is attached. Roll and reinforce top and bottom edges for stiffness. Form closed ends for surface-mounted hoods and fascia for any portion of between-jamb mounting that projects beyond wall face. Equip hood with intermediate support brackets as required to prevent sagging.

1. Galvanized Steel: Nominal 0.028-inch- thick, hot-dip galvanized-steel sheet with G90 zinc coating, complying with ASTM A 653/A 653M.

2.6 COUNTERBALANCE MECHANISM

- A. General: Counterbalance doors by means of manufacturer's standard mechanism with an adjustable-tension, steel helical torsion spring mounted around a steel shaft and contained in a spring barrel connected to top of curtain with barrel rings. Use grease-sealed bearings or self-lubricating graphite bearings for rotating members.

- B. Counterbalance Barrel: Fabricate spring barrel of manufacturer's standard hot-formed, structural-quality, seamless or welded carbon-steel pipe, of sufficient diameter and wall

thickness to support rolled-up curtain without distortion of slats and to limit barrel deflection to not more than 0.03 in./ft. of span under full load.

- C. Counterbalance Spring: One or more oil-tempered, heat-treated steel helical torsion springs. Size springs to counterbalance weight of curtain, with uniform adjustment accessible from outside barrel. Secure ends of springs to barrel and shaft with cast-steel barrel plugs.
- D. Torsion Rod for Counterbalance Shaft: Fabricate of manufacturer's standard cold-rolled steel, sized to hold fixed spring ends and carry torsional load.
- E. Brackets: Manufacturer's standard mounting brackets of either cast iron or cold-rolled steel plate.

2.7 MANUAL DOOR OPERATORS

- A. General: Equip door with manual door operator by door manufacturer.
- B. Chain-Hoist Operator: Consisting of endless steel hand chain, chain-pocket wheel and guard, and gear-reduction unit with a maximum 25-lbf force for door operation. Provide alloy-steel hand chain with chain holder secured to operator guide.

2.8 ELECTRIC DOOR OPERATORS

- A. General: Electric door operator assembly of size and capacity recommended and provided by door manufacturer for door and operation-cycles requirement specified, with electric motor and factory-prewired motor controls, starter, gear-reduction unit, solenoid-operated brake, clutch, control stations, control devices, integral gearing for locking door, and accessories required for proper operation.
 - 1. Comply with NFPA 70.
 - 2. Control equipment complying with NEMA ICS 1, NEMA ICS 2, and NEMA ICS 6, with NFPA 70 Class 2 control circuit, maximum 24-V ac or dc.
- B. Usage Classification: Electric operator and components capable of operating for not less than number of cycles per hour indicated for each door.
- C. Door Operator Location(s): Operator location indicated for each door.
 - 1. Wall Mounted: Operator is mounted to the inside front wall on the left or right side of door and connected to door drive shaft with drive chain and sprockets. Side room is required for this type of mounting. Wall-mounted operator can also be mounted above or below shaft; if above shaft, headroom is required.
- D. Motors: Reversible-type motor with controller (disconnect switch) for motor exposure indicated for each door assembly.
 - 1. Electrical Characteristics: Minimum as indicated for each door assembly. If not indicated, large enough to start, accelerate, and operate door in either direction from any position, at a speed not less than 8 in./sec. and not more than 12 in./sec., without exceeding nameplate ratings or service factor.

2. Operating Controls, Controllers, Disconnect Switches, Wiring Devices, and Wiring: Manufacturer's standard unless otherwise indicated.
 3. Coordinate wiring requirements and electrical characteristics of motors and other electrical devices with building electrical system and each location where installed.
- E. Limit Switches: Equip each motorized door with adjustable switches interlocked with motor controls and set to automatically stop door at fully opened and fully closed positions.
- F. Obstruction-Detection Devices: External entrapment protection consisting of indicated automatic safety sensor capable of protecting full width of door opening. For non-fire-rated doors, activation of device immediately stops and reverses downward door travel.
- G. Control Station: Three-button control station in fixed location with momentary-contact push-button controls labeled "Open" and "Stop" and sustained- or constant-pressure push-button control labeled "Close."
1. Interior-Mounted Units: Full-guarded, surface-mounted, heavy-duty type, with general-purpose NEMA ICS 6, Type 1 enclosure.
- H. Emergency Manual Operation: Equip each electrically powered door with capability for emergency manual operation. Design manual mechanism so required force for door operation does not exceed 25 lbf.
- I. Emergency Operation Disconnect Device: Equip operator with hand-operated disconnect mechanism for automatically engaging manual operator and releasing brake for emergency manual operation while disconnecting motor without affecting timing of limit switch. Mount mechanism so it is accessible from floor level. Include interlock device to automatically prevent motor from operating when emergency operator is engaged.
- J. Motor Removal: Design operator so motor may be removed without disturbing limit-switch adjustment and without affecting emergency manual operation.
- K. Audible and Visual Signals: Audible alarm and visual indicator lights in compliance with the accessibility standard.

2.9 GENERAL FINISH REQUIREMENTS

- A. Comply with NAAMM/NOMMA 500 for recommendations for applying and designating finishes.
- B. Appearance of Finished Work: Noticeable variations in same piece are not acceptable. Variations in appearance of adjoining components are acceptable if they are within the range of approved Samples and are assembled or installed to minimize contrast.

2.10 STEEL AND GALVANIZED-STEEL FINISHES

- A. Baked-Enamel or Powder-Coat Finish: Manufacturer's standard baked-on finish consisting of prime coat and thermosetting topcoat. Comply with coating manufacturer's written instructions for cleaning, pretreatment, application, and minimum dry film thickness.

PART 3 - EXECUTION

3.1 EXAMINATION

- A. Examine substrates areas and conditions, with Installer present, for compliance with requirements for substrate construction and other conditions affecting performance of the Work.
- B. Examine locations of electrical connections.
- C. Proceed with installation only after unsatisfactory conditions have been corrected.

3.2 INSTALLATION

- A. Install overhead coiling doors and operating equipment complete with necessary hardware, anchors, inserts, hangers, and equipment supports; according to manufacturer's written instructions and as specified.
- B. Install overhead coiling doors, hoods, controls, and operators at the mounting locations indicated for each door.

3.3 STARTUP SERVICE

- A. Engage a factory-authorized service representative to perform startup service.
 - 1. Complete installation and startup checks according to manufacturer's written instructions.
 - 2. Test and adjust controls and safety devices. Replace damaged and malfunctioning controls and equipment.
 - 3. Test door closing when activated by detector or alarm-connected automatic-closing system. Reset door-closing mechanism after successful test.

3.4 ADJUSTING

- A. Adjust hardware and moving parts to function smoothly so that doors operate easily, free of warp, twist, or distortion.
- B. Lubricate bearings and sliding parts as recommended by manufacturer.
- C. Adjust seals to provide tight fit around entire perimeter.

3.5 DEMONSTRATION

- A. Engage a factory-authorized service representative to train Owner's maintenance personnel to adjust, operate, and maintain overhead coiling doors.

END OF SECTION 083323

SECTION 263213.16 - GASEOUS EMERGENCY ENGINE GENERATORS

PART 1 - GENERAL

1.1 RELATED DOCUMENTS

- A. If the Contractor discovers any ambiguity, error, omission, conflict, or discrepancy, General Conditions Section 101.3.6 Priority of Conflicting Contract Documents shall control.
 - 1. Drawings and general provisions of the Contract, including General and Supplementary Conditions and other Division 1 Specification Sections, apply to this Section.
 - 2. State of Maine Department of Transportation, "Standard Specifications," Revision December 2014, and any revisions thereto, apply to this Section.
 - 3. Any supplements to any of the above specifications and or standards issued prior to issuance of this specification, apply to this section.
- B. Drawings and general provisions of the Contract, including General and Supplementary Conditions and Division 01 Specification Sections, apply to this Section.

1.2 SUMMARY

- A. Section includes packaged engine generators for non-emergency use with the following features:
 - 1. LP gas engine.
 - 2. Gaseous fuel system.
 - 3. Control and monitoring.
 - 4. Generator overcurrent and fault protection.
 - 5. Generator, exciter, and voltage regulator.
 - 6. Outdoor generator-set enclosure.
 - 7. Vibration isolation devices.
 - 8. Finishes.
- B. Related Requirements:
 - 1. Section 26 36 00 "Transfer Switches" for transfer switches including sensors and relays to initiate automatic-starting and -stopping signals for engine generators.

1.3 DEFINITIONS

- A. EPS: Emergency power supply.
- B. EPSS: Emergency power supply system.

- C. Operational Bandwidth: The total variation from the lowest to highest value of a parameter over the range of conditions indicated, expressed as a percentage of the nominal value of the parameter.
- D. LP: Liquefied petroleum.

1.4 ACTION SUBMITTALS

- A. Product Data: For each type of product.
 - 1. Include rated capacities, operating characteristics, electrical characteristics, and furnished specialties and accessories.
 - 2. Include thermal damage curve for generator.
 - 3. Include time-current characteristic curves for generator protective device.
 - 4. Include fuel consumption in cubic feet per hour (cubic meters per hour) at 0.8 power factor at 0.5, 0.75 and 1.0 times generator capacity.
 - 5. Include generator efficiency at 0.8 power factor at 0.5, 0.75, and 1.0 times generator capacity.
 - 6. Include air flow requirements for cooling and combustion air in cfm at 0.8 power factor, with air supply temperature of 95 deg F (35 deg C), 80 deg F (27 deg C), 70 deg F (21 deg C), and 50 deg F (10 deg C). Provide drawings showing requirements and limitations for location of air intake and exhausts.
 - 7. Include generator characteristics, including, but not limited to, kilowatt rating, efficiency, reactances, and short-circuit current capability.
- B. Shop Drawings:
 - 1. Include plans and elevations for engine generator and other components specified.
 - 2. Include details of equipment assemblies. Indicate dimensions, weights, loads, required clearances, method of field assembly, components, and location and size of each field connection.
 - 3. Identify fluid drain ports and clearance requirements for proper fluid drain.
 - 4. Vibration Isolation Base Details: Detail fabrication including anchorages and attachments to structure and to supported equipment. Include base weights.
 - 5. Include diagrams for power, signal, and control wiring. Complete schematic, wiring, and interconnection diagrams showing terminal markings for EPS equipment and functional relationship between all electrical components.

1.5 INFORMATIONAL SUBMITTALS

- A. Seismic Qualification Data: Certificates, for engine generator, accessories, and components, from manufacturer.
 - 1. Basis for Certification: Indicate whether withstand certification is based on actual test of assembled components or on calculation.
 - 2. Dimensioned Outline Drawings of Equipment Unit: With engine and generator mounted on rails, identify center of gravity and total weight, supplied enclosure, external silencer, and each piece of equipment not integral to the engine generator, and locate and describe mounting and anchorage provisions.

3. Detailed description of equipment anchorage devices on which the certification is based and their installation requirements.

B. Source Quality-Control Reports: Including, but not limited to, the following:

1. Certified summary of prototype-unit test report.
2. Certified Test Reports: For components and accessories that are equivalent, but not identical, to those tested on prototype unit.
3. Certified Summary of Performance Tests: Certify compliance with specified requirement to meet performance criteria for sensitive loads.
4. Report of factory test on units to be shipped for this Project, showing evidence of compliance with specified requirements.
5. Report of sound generation.
6. Report of exhaust emissions showing compliance with applicable regulations.

C. Field quality-control reports.

D. Warranty: For special warranty.

1.6 CLOSEOUT SUBMITTALS

A. Operation and Maintenance Data: For engine generators to include in emergency, operation, and maintenance manuals.

1. In addition to items specified in Division 01, include the following:
 - a. List of tools and replacement items recommended to be stored at Project for ready access. Include part and drawing numbers, current unit prices, and source of supply.
 - b. Operating instructions laminated and mounted adjacent to generator location.
 - c. Training plan.

1.7 MAINTENANCE MATERIAL SUBMITTALS

A. Furnish extra materials that match products installed and that are packaged with protective covering for storage and identified with labels describing contents.

1. Fuses: One for every 10 of each type and rating, but no fewer than one of each.
2. Filters: One set each of lubricating oil, fuel, and combustion-air filters.
3. Tools: Each tool listed by part number in operations and maintenance manual.

1.8 QUALITY ASSURANCE

A. Installer Qualifications: An authorized representative who is trained and approved by manufacturer.

1.9 WARRANTY

- A. Manufacturer's Warranty: Manufacturer agrees to repair or replace components of packaged engine generators and associated auxiliary components that fail in materials or workmanship within specified warranty period.
1. Warranty Period: 5 years from date of Substantial Completion.

PART 2 - PRODUCTS

2.1 MANUFACTURERS

- A. Source Limitations: Obtain packaged engine generators and auxiliary components through one source from a single manufacturer.

2.2 PERFORMANCE REQUIREMENTS

- A. Seismic Performance: Engine generator housing, engine generator, batteries, battery racks, silencers, and sound attenuating equipment, accessories, and components shall withstand the effects of earthquake motions determined according to ASCE/SEI 7.
1. The term "withstand" means "the unit will remain in place without separation of any parts when subjected to seismic forces.
 2. Shake-table testing shall comply with ICC-ES AC156. Testing shall be performed with all fluids at worst-case normal levels.
 3. Component Importance Factor: 1.0
- B. B11 Compliance: Comply with B11.19.
- C. NFPA Compliance:
1. Comply with NFPA 37
 2. Comply with NFPA 70
- D. UL Compliance: Comply with UL 2200.
- E. Engine Exhaust Emissions: Comply with EPA Tier 4 requirements and applicable state and local government requirements.
- F. Noise Emission: Comply with applicable state and local government requirements]for maximum noise level allowed at adjacent property boundaries due to sound emitted by engine generator including engine, engine exhaust, engine cooling-air intake and discharge, and other components of installation.
- G. Environmental Conditions: Engine generator system shall withstand the following environmental conditions without mechanical or electrical damage or degradation of performance capability:
1. Ambient Temperature: 5 to 104 deg F (Minus 15 to plus 40 deg C).

2. Relative Humidity: Zero to 95 percent.
3. Altitude: Sea level to 1000 feet (300 m).

H. Unusual Service Conditions: Engine generator equipment and installation are required to operate under the following conditions:

1. High salt-dust content in the air due to proximity to ocean.

2.3 ENGINE GENERATOR ASSEMBLY DESCRIPTION

- A. Factory-assembled and -tested, water-cooled engine, with brushless generator and accessories.
- B. Electrical Components, Devices, and Accessories: Listed and labeled as defined in NFPA 70, by a testing agency acceptable to authorities having jurisdiction, and marked for intended location and use.
- D. Overload Capacity: 110 percent of service load for 1 hour in 12 consecutive hours.
- E. Power Factor: 0.8, lagging.
- F. Frequency: 60 Hz
- G. Voltage: 120/240 V ac.
- H. Phase: single phase wire, wye
- I. Induction Method: Naturally aspirated.
- J. Governor: Adjustable isochronous, with speed sensing.
- K. Mounting Frame: Structural steel framework to maintain alignment of mounted components without depending on concrete foundation. Provide lifting attachments sized and spaced to prevent deflection of base during lifting and moving.
 1. Rigging Diagram: Inscribed on metal plate permanently attached to mounting frame to indicate location and lifting capacity of each lifting attachment and generator-set center of gravity.
- L. Capacities and Characteristics:
 1. Power Output Ratings: Nominal ratings as indicated at 0.8 power factor excluding power required for the continued and repeated operation of the unit and auxiliaries.
 2. Nameplates: For each major system component to identify manufacturer's name and address, and model and serial number of component.
- M. Engine Generator Performance:

1. Steady-State Voltage Operational Bandwidth: 3 percent of rated output voltage from no load to full load.
2. Transient Voltage Performance: Not more than 20 percent variation for 50 percent step-load increase or decrease. Voltage shall recover and remain within the steady-state operating band within three seconds.
3. Steady-State Frequency Operational Bandwidth: 0.5 percent of rated frequency from no load to full load.
4. Steady-State Frequency Stability: When system is operating at any constant load within the rated load, there shall be no random speed variations outside the steady-state operational band and no hunting or surging of speed.
5. Transient Frequency Performance: Less than 5 percent variation for 50 percent step-load increase or decrease. Frequency shall recover and remain within the steady-state operating band within five seconds.
6. Output Waveform: At no load, harmonic content measured line to line or line to neutral shall not exceed 5 percent total and 3 percent for single harmonics. Telephone influence factor, determined according to NEMA MG 1, shall not exceed 50 percent.
7. Sustained Short-Circuit Current: For a three-phase, bolted short circuit at system output terminals, system shall supply a minimum of 250 percent of rated full-load current for not less than 10 seconds and then clear the fault automatically, without damage to generator system components.

2.4 GASEOUS ENGINE

- A. Fuel: LP gas
- B. Rated Engine Speed: 1800 rpm.
- C. Lubrication System: Engine or skid-mounted.
 1. Filter and Strainer: Rated to remove 90 percent of particles 5 micrometers and smaller while passing full flow.
 2. Thermostatic Control Valve: Control flow in system to maintain optimum oil temperature. Unit shall be capable of full flow and is designed to be fail-safe.
 3. Crankcase Drain: Arranged for complete gravity drainage to an easily removable container with no disassembly and without use of pumps, siphons, special tools, or appliances.
- D. Jacket Coolant Heater: Electric-immersion type, factory installed in coolant jacket system. Comply with UL 499.
- E. Cooling System: Closed loop, liquid cooled, with radiator factory mounted on engine generator mounting frame and integral engine-driven coolant pump.
 1. Coolant: Solution of 50 percent ethylene-glycol-based antifreeze and 50 percent water, with anticorrosion additives as recommended by engine manufacturer.
 2. Size of Radiator: Adequate to contain expansion of total system coolant from cold start to 110 percent load condition.
 3. Expansion Tank: Constructed of welded steel plate and rated to withstand maximum closed-loop coolant system pressure for engine used. Equip with gage glass and petcock.

4. Temperature Control: Self-contained, thermostatic-control valve modulates coolant flow automatically to maintain optimum constant coolant temperature as recommended by engine manufacturer.
5. Coolant Hose: Flexible assembly with inside surface of nonporous rubber and outer covering of aging-, ultraviolet-, and abrasion-resistant fabric.
 - a. Rating: 50-psig (345-kPa) maximum working pressure with coolant at 180 deg F (82 deg C), and noncollapsible under vacuum.
 - b. End Fittings: Flanges or steel pipe nipples with clamps to suit piping and equipment connections.
- F. Muffler/Silencer and Sound attenuation enclosure: Critical type, sized as recommended by engine manufacturer and selected with exhaust piping system to not exceed engine manufacturer's engine backpressure requirements.
 1. Minimum sound attenuation of 25 dB at 500 Hz.
 2. Sound level measured at the property line shall comply with the local ordinance for sound levels at the property line.
- G. Air-Intake Filter: standard-duty, engine-mounted air cleaner with replaceable dry-filter element and "blocked filter" indicator.
- H. Starting System: 12 V electric, with negative ground.
 1. Components: Sized so they are not damaged during a full engine-cranking cycle with ambient temperature at maximum specified in "Performance Requirements" Article.
 2. Cranking Motor: Heavy-duty unit that automatically engages and releases from engine flywheel without binding.
 3. Cranking Cycle: 60 seconds.
 4. Battery: Lead acid with capacity within ambient temperature range specified in "Performance Requirements" Article to provide specified cranking cycle at least twice] without recharging.
 5. Battery Cable: Size as recommended by engine manufacturer for cable length indicated. Include required interconnecting conductors and connection accessories.
 6. Battery Compartment: Factory fabricated of metal with acid-resistant finish and thermal insulation. Thermostatically controlled heater shall be arranged to maintain battery above 50 deg F (10 deg C) regardless of external ambient temperature within range specified in "Performance Requirements" Article. Include accessories required to support and fasten batteries in place. Provide ventilation to exhaust battery gases.
 7. Battery Stand: Factory-fabricated, two-tier metal with acid-resistant finish designed to hold the quantity of battery cells required and to maintain the arrangement to minimize lengths of battery interconnections.
 8. Battery-Charging Alternator: Factory mounted on engine with solid-state voltage regulation and 35 A minimum continuous rating.
 9. Battery Charger: Current-limiting, automatic-equalizing and float-charging type designed for lead acid batteries. Unit shall comply with UL 1236 and include the following features:
 - a. Operation: Equalizing-charging rate of 10 A shall be initiated automatically after battery has lost charge until an adjustable equalizing voltage is achieved at battery

terminals. Unit shall then be automatically switched to a lower float-charging mode and shall continue to operate in that mode until battery is discharged again.

- b. Automatic Temperature Compensation: Adjust float and equalize voltages for variations in ambient temperature from minus 40 deg F (minus 40 deg C) to 140 deg F (plus 60 deg C) to prevent overcharging at high temperatures and undercharging at low temperatures.
- c. Automatic Voltage Regulation: Maintain constant output voltage regardless of input voltage variations up to plus or minus 10 percent.
- d. Ammeter and Voltmeter: Flush mounted in door. Meters shall indicate charging rates.
- e. Safety Functions: Sense abnormally low battery voltage and close contacts providing low battery voltage indication on control and monitoring panel. Sense high battery voltage and loss of ac input or dc output of battery charger. Either condition shall close contacts that provide a battery-charger malfunction indication at system control and monitoring panel.
- f. Enclosure: NEMA 250, Type 1 mounted within generator enclosure.

2.5 GASEOUS FUEL SYSTEM

- A. LP Gas Piping: Comply with requirements in Division 22.
- B. Gas Train: Comply with NFPA 37.
- C. LP gas Vapor-Withdrawal System:
 - 1. Carburetor.
 - 2. Secondary Gas Regulator: with atmospheric vents piped to building exterior.
 - 3. Fuel-Shutoff Solenoid Valves: NRTL-listed, normally closed, safety shutoff valves; one for each fuel source.
 - 4. Fuel Filter
 - 5. Manual Fuel Shutoff Valve
 - 6. Flexible Fuel Connector.

2.6 CONTROL AND MONITORING

- A. Automatic Starting System Sequence of Operation: When mode-selector switch on the control and monitoring panel is in the automatic position, remote-control contacts in one or more separate automatic transfer switches initiate starting and stopping of engine generator. When mode-selector switch is switched to the on position, engine generator starts. The off position of same switch initiates generator-set shutdown. When engine generator is running, specified system or equipment failures or derangements automatically shut down engine generator and initiate alarms.
- B. Manual Starting System Sequence of Operation: Switching on-off switch on the generator control panel to the on position starts engine generator. The off position of same switch initiates generator-set shutdown. When engine generator is running, specified system or equipment failures or derangements automatically shut down engine generator and initiate alarms.

- C. Provide minimum run time control set for 15 minutes with override only by operation of a remote emergency-stop switch.
- D. Comply with UL 508A.
- E. Configuration: Operating and safety indications, protective devices, basic system controls, and engine gages shall be grouped in a common control and monitoring panel mounted on the engine generator. Mounting method shall isolate the control panel from generator-set vibration. Panel shall be powered from the engine generator battery.
- F. Control and Monitoring Panel:
 - 1. Digital controller with integrated LCD, controls, and microprocessor, capable of local and remote control, monitoring, and programming, with battery backup.
 - 2. Analog control panel with dedicated gages and indicator lights for the instruments and alarms indicated below.
 - 3. Instruments: Located on the control and monitoring panel and viewable during operation.
 - a. Engine lubricating-oil pressure gage.
 - b. Engine-coolant temperature gage.
 - c. DC voltmeter (alternator battery charging).
 - d. Running-time meter.
 - e. AC voltmeter, for each phase
 - f. AC ammeter, for each phase
 - g. AC frequency meter.
 - h. Generator-voltage adjusting rheostat.
 - 4. Controls and Protective Devices: Controls, shutdown devices, and common visual alarm indication, including the following:
 - a. Cranking control equipment.
 - b. Run-Off-Auto switch.
 - c. Control switch not in automatic position alarm.
 - d. Overcrank alarm.
 - e. Overcrank shutdown device.
 - f. Low water temperature alarm.
 - g. High engine temperature prealarm.
 - h. High engine temperature.
 - i. High engine temperature shutdown device.
 - j. Overspeed alarm.
 - k. Overspeed shutdown device.
 - l. Low fuel main tank.
 - m. Coolant low-level alarm.
 - n. Coolant low-level shutdown device.
 - o. Coolant high-temperature prealarm.
 - p. Coolant high-temperature alarm.
 - q. Coolant low-temperature alarm.
 - r. Coolant high-temperature shutdown device.
 - s. EPS supplying load indicator.
 - t. Battery high-voltage alarm.
 - u. Low cranking voltage alarm.

- v. Battery-charger malfunction alarm.
- w. Battery low-voltage alarm.
- x. Lamp test.
- y. Contacts for local and remote common alarm.
- z. Low-starting air pressure alarm.
- aa. Low-starting hydraulic pressure alarm.
- bb. Remote manual stop shutdown device.
- cc. Air shutdown damper alarm when used.
- dd. Air shutdown damper shutdown device when used.
- ee. Hours of operation.
- ff. Engine generator metering, including voltage, current, Hz, kW, kVA, and power factor.
- gg. Generator overcurrent protective device not closed alarm.

G. Engine Generator Metering: Comply with Section 26 27 13 "Electricity Metering."

H. Connection to Datalink:

- 1. A separate terminal block, factory wired to Form C dry contacts, for each alarm and status indication.

I. Common Remote Panel with Common Audible Alarm: Include necessary contacts and terminals in control and monitoring panel. Remote panel shall be powered from the engine generator battery.

J. Supporting Items: Include sensors, transducers, terminals, relays, and other devices and include wiring required to support specified items. Locate sensors and other supporting items on engine or generator, unless otherwise indicated.

2.7 GENERATOR OVERCURRENT AND FAULT PROTECTION

A. Overcurrent protective devices for the entire EPSS shall be coordinated to optimize selective tripping when a short circuit occurs. Coordination of protective devices shall consider both utility and EPSS as the voltage source.

- 1. Overcurrent protective devices for the EPSS shall be accessible only to authorized personnel.

B. Generator Circuit Breaker: Molded-case, electronic-trip type; 100 percent rated; complying with UL 489.

- 1. Tripping Characteristics: Adjustable long-time and short-time delay and instantaneous.
- 2. Trip Settings: Selected to coordinate with generator thermal damage curve.
- 3. Shunt Trip: Connected to trip breaker when engine generator is shut down by other protective devices.
- 4. Mounting: Adjacent to or integrated with control and monitoring panel.

C. Generator Protector: Microprocessor-based unit shall continuously monitor current level in each phase of generator output, integrate generator heating effect over time, and predict when thermal damage of alternator will occur. When signaled by generator protector or other

generator-set protective devices, a shunt-trip device in the generator disconnect switch shall open the switch to disconnect the generator from load circuits. Protector performs the following functions:

1. Initiates a generator overload alarm when generator has operated at an overload equivalent to 110 percent of full-rated load for 60 seconds. Indication for this alarm is integrated with other generator-set malfunction alarms. Contacts shall be available for load shed functions.
2. Under single or three-phase fault conditions, regulates generator to 300 percent of rated full-load current for up to 10 seconds.
3. As overcurrent heating effect on the generator approaches the thermal damage point of the unit, protector switches the excitation system off, opens the generator disconnect device, and shuts down the engine generator.
4. Senses clearing of a fault by other overcurrent devices and controls recovery of rated voltage to avoid overshoot.

2.8 GENERATOR, EXCITER, AND VOLTAGE REGULATOR

- A. Comply with NEMA MG 1.
- B. Drive: Generator shaft shall be directly connected to engine shaft. Exciter shall be rotated integrally with generator rotor.
- C. Electrical Insulation: Class H
- D. Stator-Winding Leads: Brought out to terminal box to permit future reconnection for other voltages if required. Provide six lead alternator.
- E. Range: Provide limited range of output voltage by adjusting the excitation level.
- F. Construction shall prevent mechanical, electrical, and thermal damage due to vibration, overspeed up to 125 percent of rating, and heat during operation at 110 percent of rated capacity.
- G. Enclosure: Drip proof.
- H. Instrument Transformers: Mounted within generator enclosure.
- I. Voltage Regulator: Solid-state type, separate from exciter.
 1. Adjusting Rheostat on Control and Monitoring Panel: Provide plus or minus 5 percent adjustment of output-voltage operating band.
 2. Maintain voltage within 30 percent on one step, full load.
 3. Provide anti-hunt provision to stabilize voltage.
 4. Maintain frequency within 10 percent and stabilize at rated frequency within 5 seconds.
- J. Strip Heater: Thermostatically controlled unit arranged to maintain stator windings above dew point.

- K. Windings: Two-thirds pitch stator winding and fully linked amortisseur winding.
- L. Subtransient Reactance: 12 percent, maximum.

2.9 OUTDOOR GENERATOR-SET ENCLOSURE

- A. Description: Vandal-resistant, sound-attenuating, weatherproof steel housing, wind resistant up to 100 mph (160 km/h). Multiple panels shall be lockable and provide adequate access to components requiring maintenance. Panels shall be removable by one person without tools. Instruments and control shall be mounted within enclosure.
 - 1. Sound Attenuation Level: as required to be below the local property line dBA requirement limits.
- B. Description: Prefabricated or pre-engineered galvanized-steel-clad, integral structural-steel-framed, walk-in enclosure, erected on concrete foundation.
- C. Structural Design and Anchorage: Comply with ASCE/SEI 7 for wind loads up to 100 mph (160 km/h).
- D. Seismic Design: Comply with seismic requirements in Section 26 05 48.16 "Seismic Controls for Electrical Systems."
- E. Hinged Doors: With padlocking provisions.
- F. Space Heater: Thermostatically controlled and sized to prevent condensation.
- G. Thermal Insulation: Manufacturer's standard materials and thickness selected in coordination with space heater to maintain winter interior temperature within operating limits required by engine generator components.
- H. Muffler Location: within enclosure.
- I. Engine Cooling Airflow through Enclosure: Maintain temperature rise of system components within required limits when unit operates at 110 percent of rated load for 2 hours with ambient temperature at top of range specified in system service conditions.
 - 1. Louvers: Fixed-engine, cooling-air inlet and discharge. Storm-proof and drainable louvers prevent entry of rain and snow.
 - 2. Automatic Dampers: At engine cooling-air inlet and discharge. Dampers shall be closed to reduce enclosure heat loss in cold weather when unit is not operating.
 - 3. Ventilation: Provide temperature-controlled exhaust fan interlocked to prevent operation when engine is running.
- J. Convenience Outlets: Factory wired, GFCI. Arrange for external electrical connection.

2.10 VIBRATION ISOLATION DEVICES

- A. Elastomeric Isolator Pads: Oil- and water-resistant elastomer or natural rubber, arranged in single or multiple layers, molded with a nonslip pattern and galvanized-steel baseplates of

sufficient stiffness for uniform loading over pad area, and factory cut to sizes that match requirements of supported equipment.

1. Material: standard neoprene separated by steel shims.
2. Shore "A" Scale Durometer Rating: 30
3. Number of Layers: one.
4. Minimum Deflection: 1 inch

B. Restrained Spring Isolators: Freestanding, steel, open-spring isolators with seismic restraint.

1. Housing: Steel with resilient vertical-limit stops to prevent spring extension due to wind loads or if weight is removed; factory-drilled baseplate bonded to ~~1/4-inch-~~ (6-mm-) thick, elastomeric isolator pad attached to baseplate underside; and adjustable equipment mounting and leveling bolt that acts as blocking during installation.
2. Outside Spring Diameter: Not less than 80 percent of compressed height of the spring at rated load.
3. Minimum Additional Travel: 50 percent of required deflection at rated load.
4. Lateral Stiffness: More than 80 percent of rated vertical stiffness.
5. Overload Capacity: Support 200 percent of rated load, fully compressed, without deformation or failure.
6. Minimum Deflection: 1 inch

C. Comply with requirements in Division 23 for vibration isolation and flexible connector materials for steel piping.

D. Vibration isolation devices shall not be used to accommodate misalignments or to make bends.

2.11 FINISHES

A. Indoor and Outdoor Enclosures and Components: Manufacturer's standard finish over corrosion-resistant pretreatment and compatible primer.

2.12 SOURCE QUALITY CONTROL

A. Prototype Testing: Factory test engine generator using same engine model, constructed of identical or equivalent components and equipped with identical or equivalent accessories.

1. Tests: Comply with IEEE 115.

PART 3 - EXECUTION

3.1 EXAMINATION

A. Examine areas, equipment bases, and conditions, with Installer present, for compliance with requirements for installation and other conditions affecting packaged engine generator performance.

- B. Examine roughing-in for piping systems and electrical connections. Verify actual locations of connections before packaged engine generator installation.
- C. Proceed with installation only after unsatisfactory conditions have been corrected.

3.2 INSTALLATION

- A. Comply with NECA 1 and NECA 404.
- B. Equipment Mounting:
 - 1. Install packaged engine generators on cast-in-place concrete equipment bases. Comply with requirements for equipment bases and foundations specified in Section 03 30 00 "Cast-in-Place Concrete."
 - 2. Coordinate size and location of concrete bases for packaged engine generators. Cast anchor-bolt inserts into bases. Concrete, reinforcement, and formwork requirements are specified with concrete.
 - 3. Install packaged engine generator with elastomeric isolator pads having a minimum deflection of 1 inch (25 mm) on 4-inch- (100-mm-) high concrete base. Secure engine generator enclosure to anchor bolts installed in concrete bases. Concrete base construction is specified in Section 26 05 48.16 "Seismic Controls for Electrical Systems."
- C. Install packaged engine generator to provide access, without removing connections or accessories, for periodic maintenance.
- D. Electrical Wiring: Install electrical devices furnished by equipment manufacturers but not specified to be factory mounted.

3.3 CONNECTIONS

- A. Piping installation requirements are specified in other Sections. Drawings indicate general arrangement of piping and specialties.
- B. Connect fuel piping adjacent to packaged engine generator to allow service and maintenance.
- C. Gaseous Fuel Connections:
 - 1. Connect fuel piping to engines with a gate valve and union and flexible connector.
 - 2. Install manual shutoff valve in a remote location to isolate gaseous fuel supply to the generator.
 - 3. Vent gas pressure regulators outside building a minimum of 60 inches (1500 mm) from building openings.
- D. Ground equipment according to Section 26 05 26 "Grounding and Bonding for Electrical Systems."
- E. Connect wiring according to Section 26 05 19 "Low-Voltage Electrical Power Conductors and Cables." Provide a minimum of one 90-degree bend in flexible conduit routed to the engine generator from a stationary element.

- F. Balance single-phase loads to obtain a maximum of 10 percent unbalance between any two phases.

3.4 IDENTIFICATION

- A. Identify system components according to Section 23 05 53 "Identification for HVAC Piping and Equipment" and Section 26 05 53 "Identification for Electrical Systems."
- B. Install a sign indicating the generator neutral is bonded to the main service neutral at the main service location.

3.5 FIELD QUALITY CONTROL

- A. Manufacturer's Field Service: Engage a factory-authorized service representative to test and inspect components, assemblies, and equipment installations, including connections.
- B. Tests and Inspections:
 - 1. Perform tests recommended by manufacturer and each visual and mechanical inspection and electrical and mechanical test listed in the first two subparagraphs below as specified in the NETA ATS. Certify compliance with test parameters.
 - a. Visual and Mechanical Inspection
 - 1) Compare equipment nameplate data with drawings and specifications.
 - 2) Inspect physical and mechanical condition.
 - 3) Inspect anchorage, alignment, and grounding.
 - 4) Verify the unit is clean.
 - b. Electrical and Mechanical Tests
 - 1) Perform insulation-resistance tests in accordance with IEEE 43.
 - a) Machines larger than 200 hp (150 kW). Test duration shall be 10 minutes. Calculate polarization index.
 - b) Machines 200 hp (150 kW) or less. Test duration shall be one minute. Calculate the dielectric-absorption ratio.
 - 2) Test protective relay devices.
 - 3) Verify phase rotation, phasing, and synchronized operation as required by the application.
 - 4) Functionally test engine shutdown for low oil pressure, overtemperature, overspeed, and other protection features as applicable.
 - 5) Perform vibration test for each main bearing cap.
 - 6) Verify correct functioning of the governor and regulator.
 - 2. Battery Tests: Equalize charging of battery cells according to manufacturer's written instructions. Record individual cell voltages.

- a. Measure charging voltage and voltages between available battery terminals for full-charging and float-charging conditions. Check electrolyte level and specific gravity under both conditions.
 - b. Test for contact integrity of all connectors. Perform an integrity load test and a capacity load test for the battery.
 - c. Verify acceptance of charge for each element of the battery after discharge.
 - d. Verify that measurements are within manufacturer's specifications.
3. Battery-Charger Tests: Verify specified rates of charge for both equalizing and float-charging conditions.
 4. System Integrity Tests: Methodically verify proper installation, connection, and integrity of each element of engine generator system before and during system operation. Check for air, exhaust, and fluid leaks.
 5. Exhaust Emissions Test: Comply with applicable government test criteria.
 6. Voltage and Frequency Transient Stability Tests: Use recording oscilloscope to measure voltage and frequency transients for 50 and 100 percent step-load increases and decreases, and verify that performance is as specified.
 7. Noise Level Tests: Measure A-weighted level of noise emanating from generator-set installation, including engine exhaust and cooling-air intake and discharge, at four locations 25 feet (8 m) from edge of the generator enclosure, on the property line, and compare measured levels with required values.
- C. Coordinate tests with tests for transfer switches and run them concurrently.
 - D. Test instruments shall have been calibrated within the last 12 months, traceable to NIST Calibration Services, and adequate for making positive observation of test results. Make calibration records available for examination on request.
 - E. Leak Test: After installation, charge exhaust, coolant, and fuel systems and test for leaks. Repair leaks and retest until no leaks exist.
 - F. Operational Test: After electrical circuitry has been energized, start units to confirm proper motor rotation and unit operation for generator and associated equipment.
 - G. Test and adjust controls and safeties. Replace damaged and malfunctioning controls and equipment.
 - H. Remove and replace malfunctioning units and retest and reinspect as specified above.
 - I. Retest: Correct deficiencies identified by tests and observations and retest until specified requirements are met.
 - J. Report results of tests and inspections in writing. Record adjustable relay settings and measured insulation resistances, time delays, and other values and observations. Attach a label or tag to each tested component indicating satisfactory completion of tests.
- 3.6 MAINTENANCE SERVICE
- A. Initial Maintenance Service: Beginning at Substantial Completion, provide 12 months' full maintenance by skilled employees of manufacturer's designated service organization. Include

quarterly exercising to check for proper starting, load transfer, and running under load. Include routine preventive maintenance as recommended by manufacturer and adjusting as required for proper operation. Provide parts and supplies same as those used in the manufacture and installation of original equipment.

3.7 DEMONSTRATION

- A. Engage a factory-authorized service representative to train Owner's maintenance personnel to adjust, operate, and maintain packaged engine generators.

3.8 Certifications

- A. Provide Tier V certificates as required to EPA and other agencies as required for certification of the generator.

END OF SECTION 263213

MTA Addenda Questions - Contract 2019.12 ADDENDUM 1

1-Nov-19				
Contractor/Vendor	Sheet	Plan/Spec	Question	AEI Team Response/Resolution
Sheridan Construction			Has the project been permitted	AEI: State Fire Marshal permit will be handled by AEI Project Team. GC will be responsible for plumbing and electrical permits
		1.33419-1.9-B	Requires warranty for standing seam roofing – N/A, this is a rubber roof.	AEI: Referenced subsection Delete per Addendum 1.
	SB-100		Foundation Note 3 – BOF at 5'-0" minimum below finish grade. Details on Sheet A-8 depict 4'-6" below finish floor. Which is correct?	AEI: The correct frost depth per S. W. Cole Report dated April 18, 2018 is 5'-0" (100 Year AFF). SW Cole report is included in the contract documents.
	A-4		Please update A-4 to depict all the roof penetrations that are shown on the mechanical plans. A-4 would lead you to believe that it is a clear roof, which it is not.	AEI: Drawing A-4 reissued in its entirety with back clouded changes.
	S-000		We do not see a collateral load. There is a dead load of 20 PSF, which includes 8 PSF for future solar array. Please confirm collateral load as it is different than dead load. Dead load includes the weight of the structure itself.	AEI: Provide Roof Dead Load of 17 psf; Collateral Loading of 3 PSF, and Future Solar system equipment DL of 8 psf.
	SF-100		Why is the bottom of steel elevation for the W12x30 beam from C5 to C6 at 14' AFF with the OH Door headers at 16' tall? Is this a drive thru bay?	AEI: Revise to reflect W12x30 bottom of beam elevation to 16'0" AFF.
	S-000		Structural note 1-B-a-1-C – Why is the building thermal factor 1.10 (just above freezing)? Isn't this a heated building?	AEI: Our interpretation of ASCE7-10, Chapter 7, Table 7-3 is that once the R-value for any roof system exceeds R-25 or better, that the roof is then considered to be a cold roof and not subject to quick/constant heat loss melting. We are not open to alternate consideration on this issue.
	A-4		Roof Hatch – Where is the specification for the hatch? Also, A-4 depicts it located over centerline of frame 3.	AEI: SECTION 077200 - ROOF ACCESSORIES included Addendum 1. Hatch shifted plan West.
	A-4/PL-100		Roof Drain Leaders – Plan PL-100.4" RW locations are not in the same location as the roof drains depicted on A-4. Please confirm RW locations.	AEI: PL-100 updated to coordinate with Drain locations presented on A-4.
Glidden Paving			Will hot rubber joint sealant be required for the surface pavement?	GPCEI: Hot rubber joint sealant will not be required between the new pavement and existing pavement at the facility
			Is there asphalt escalation for this project?	MTA: Yes, page 106 of Supplementals. We have 675 ton in this job
Sheridan Construction			Please provide a specification for coiling door #117	AEI: Specification Section 083323 included Addendum 1.
St. Laurent & Son Paving		SP-15, Section 403	Please clarify if we need to use 64E-28 for the asphalt mix	MTA: 64-28 is to be used here, NOT 64E-28. The E is the polymer modified that we use on mainline
		SP-15, Section 403	Please clarify if we need to use a transfer vehicle (MTV) in install the surface course asphalt	MTA: No
Blaine Casey			Please provide a specification for the roof hatch.	AEI: SECTION 077200 - ROOF ACCESSORIES included Addendum 1. Hatch shifted plan West.
			The metal edge roof fascia is not clearly labeled. Please provide additional information on desired roof edge fascia.	GHA: Section 077200 - Roof Accessories has been added to the project manual specifications.
Standard Waterproofing		Section 072119	In the specs Section 072119 calls a for Foamed-In-Place Insulation, I don't see any on drawings?	GHA: Foam-In-Place Insulation shall be used in voids too small for other specified insulation, such as electrical penetrations, etc.
	SB-500		On Drawing SB 500 Detail F4 they are calling for a Bentonite Sealant at full Perimeter of catch basin cover, this is old technology, would a urethane be good enough? Such as Sika 2C NS Sealant?	WPF: Sika2c NS Sealant is an acceptable alternative for this application.

Litchfield Garage Pre-Bid Meeting

Date: 10/22/2019

Location: MTA HQ

	NAME	Email	Company	Phone#
1	(Joe Bumps)	j.bumps@blencasey.com	Blenc Casey	441-5045
2	(Jeff Becker)	j.becker@blencasey.com	LC CA	622-5600
3	Shoshanna Starks	Shoshanna@crooker.com	Crooker Const	729-3331
4	Ian Rivette	iprivette@crooker.com	CROOKER	504-6622
5	Tyler Coffin	Tyler@dotens.com	Doten's Const.	866-4412
6	Joe Goodspeed	Joe@dotens.com	Doten's Const.	735-6611
7	Jim Anderson	janderson@sheridancorp.com	Sheridan	774-6138
8	Joe Perryman	joe@stlaurentandson.com	St. Laurent & Son	789-2944
9	MIKE DIMATTEO	DIMATTEOENS@YAHOO	DIMATTEO	767-7410
10	Greg Hildebrand	rchute@nickoday.com	Nickerson & O'Day	989-7400
11	John Canneil	jcanneil@mainetemplates.com	MTA	207-592-1151
12	BRIAN TADDEO	btaddeo@mainetemplates.com	MTA	207-882-8297
13				
14				
15				
16				
17				
18				
19				
20				
21				
22				
23				
24				
25				
26				
27				

Please see attached training documentation for further details