

ADDENDUM 1_April 11, 2024

FROM: Allied Engineering, Inc.
160 Veranda Street
Portland, Maine 04103
Telephone: (207) 221-2260

TO: Prospective Bidders, Suppliers, and Other Parties

RE: Addendum No. **One (1)** to the Bidding Documents for:
York Maintenance Facility Vehicle Storage Garage, Mile 6.8, York, ME

This Addendum forms a part of the Contract Documents and modifies the original Bidding Documents dated March 25, 2024. Acknowledge receipt of this Addendum in the space provided on the Proposal Form. Failure to do so may subject Bidder to disqualification.

GENERAL

1. During the project, the contractor will be responsible for coordinating with MTA during the winter/plowing season. MTA must be able to continue to operate and function during this project. Any trenching completed during the day must be filled back in to grade to ensure MTA has to ability to get in and out and maintain the roads.
2. The site is available to visit during business hours. Coordinate with Steve Tartre of MTA at 207.482.8369; startre@maineturnpike.com.
3. Bid Due date has changed to April 23, 2024 and shall be received until 1:00 p.m., prevailing time as determined by the Authority.
4. Final date of submitted questions shall be Tuesday April 16, 2024 5:00 PM.
5. Addendum #2 will be issued on April 18, 2024. All questions/forms shall be directed to Nate Carll of MTA via email; ncarll@mainturnpike.com.

QUESTIONS

1. **Drawing A-7** The structural drawings are showing typical foundation wall to be 8” width. Detail 4/A-7 shows a 10” wall.
AEI Response: All foundation walls are 8" as shown on structural drawings.
2. **Drawing C-101 and C-401:** There appears to be a discrepancy between the propane tank dimensions indicated on the Site and Utility Plan C-101 & the Precast Propane Tank Pad detail on sheet C-401.
AEI Response: The detail on Sheet C401 has been revised so that the pad dimensions match those depicted on the Site Plan.
3. **Specification Section 033000:** Are the reinforcing bar supports in the slab required to be epoxy coated?
AEI Response: No, bolsters are not required to be epoxy coated.
4. **Specification Section 077200:** Specification includes a spec for Roof Curbs. I don’t see where this would pertain.
AEI Response: There are no roof curbs on this project.

5. **Special Provisions:** Would it be acceptable to complete the substantial completion this year within the 240 days including base pavement and do final pavement Spring 2025 without being assessed liquidated damages or is the 240 complete set-in stone?

AEI Response: If the onset of winter conditions inhibits the contractor's ability to finish the work, then the contractor may request in writing the Authority approve a Winter Suspension, as noted in Section 107.5.1 of the MTA Supplemental Specifications.

6. **Special Provisions:** It appears Special Provision Section 800 is requiring a compete BIM coordination design for the building. Please confirm if this is the intent.

AEI Response: Full BIM coordination design will not be required for this project.

7. **Special Provisions:** Is hot rubber joint sealant required for the surface pavement?

AEI Response: No.

SPECIFICATIONS

1. **DELETE** PART II BID FORMS in its entirety. **ADD** in its place "BID FORM_Addendum 1_4-11,2024".
2. **DELETE** PART II - SPECIAL PROVISIONS in its entirety. **ADD** in its place "PART II - SPECIAL PROVISIONS Addendum 1_4-11-2024".
3. Specification Section 220533-Heat Tracing for Plumbing Piping: **ADD** section, attached, in its entirety.
4. Specification Section 230700-Mechanical Insulation: **DELETE** Paragraph 3.6 G in its entirety. **ADD** in its place the following:

"G. Domestic hot water:

1. Runouts and non-recirculated portions: Glass Fiber 1/2" thickness.
2. Heat traced DHW piping: 1-1/4" and less: Glass Fiber, 1" thickness; 1-1/2 and larger: Glass Fiber, 1.5" thickness."

PLANS SHEETS & SKETCHES

1. **DELETE** Sheet 5 of 32 - Site and Utility Plan in its entirety. **ADD** in its place, Sheet 5 of 32 – Site and Utility Plan, attached, reissued with revisions.
2. **DELETE** Sheet 6 of 32 - Grading, Drainage, Erosion Control Plan in its entirety. **ADD** in its place, Sheet 6 of 32– Grading, Drainage, Erosion Control Plan, attached, reissued with revisions.
3. **DELETE** Sheet 7 of 32 - Details 1 Plan in its entirety. **ADD** in its place, Sheet 7 of 32 – Details 1 Plan, attached, reissued with revisions.
4. **DELETE** Sheet 12 of 32 – Code Compliance and First Floor Plan in its entirety. **ADD** in its place, Sheet 12 of 32 – Code Compliance and First Floor Plan, attached, reissued with revisions.
5. **DELETE** Sheet 26 of 32 - Domestic Piping Plan in its entirety. **ADD** in its place, Sheet 26 of 32 – Domestic Piping Plan, attached, reissued with revisions.

6. **DELETE** Sheet 28 of 32 - Electrical Site Plan in its entirety. **ADD** in its place, Sheet 28 of 32 – Electrical Site Plan, attached, reissued with revisions.
7. **DELETE** Sheet 30 of 32 - Electrical General Notes and Schedules in its entirety. **ADD** in its place, Sheet 30 of 32 - Electrical General Notes and Schedules, attached, reissued with revisions.
8. **DELETE** Sheet 32 of 32 - Power and Systems Plan in its entirety. **ADD** in its place, Sheet 32 of 32 - Power and Systems Plan, attached, reissued with revisions.

ATTACHMENTS

A. Addendum 1 Summary Document	(3 Pages)
B. Specifications	(54 Pages)
C. Plan Sheets and Sketches	(9 Pages)
Total Page Count	<u>66 Pages</u>

MAINE TURNPIKE AUTHORITY

YORK VEHICLE STORAGE GARAGE

CONTRACT 2024.09

ADDENDUM #1 4-11-24

TO MAINE TURNPIKE AUTHORITY:

The work consists of the following:

1. Construction of an approximate 6,600 square foot pre-engineered building consisting of six (6) equipment storage garage bays.
2. All site work, grading, drainage, underground power, power utility services and site utilities.

The work includes all building structure, mechanical, electrical, and plumbing, as well as all site work, grading, pavement, lighting, utilities, and all other work incidental thereto in accordance with the Plans and Specifications.

This Work will be done under a Contract known as Contract 2024.09 according to the Plans and Specifications which are on file in the office of the Maine Turnpike Authority, 2360 Congress Street, Portland, Maine.

On the acceptance of this Proposal for said Work, the undersigned will give the required bond with good security conditioned for the faithful performance of said Work, according to said Plans and Specifications, and the doing of all other work required by said Specifications for the consideration herein named and with the further condition that the Maine Turnpike Authority shall be saved harmless from any and all damages that might accrue to any person, persons or property by reason of the carrying out of said Work, or any part thereof, or by reason of negligence of the undersigned, or any person or persons under his employment and engaged in said Work.

The undersigned hereby declares that he/she has carefully examined the Plans, Specifications and other Contract Documents, and that he/she will contract to carry out and complete the said Work as specified and delineated at the price per unit of measure for each scheduled item of Work stated in the Schedule of Prices as follows:

It is understood that the TOTAL AMOUNT stated by the undersigned in the following Schedule of Prices is based on approximate quantities and will be used solely for the comparison of bids, and that the quantities stated in the Schedule of Prices for the various items are estimates only and may be increased or decreased all as provided in the Specifications.

Item No	Item Description	Units	Approx. Quantities	Unit Prices in Numbers		Bid Amount in Numbers	
203.20	COMMON EXCAVATION	CY	100				
203.25	GRANULAR BORROW	CY	100				
203.2312	HEALTH & SAFETY PLAN	LS	1				
203.2333	DISPOSAL/TREATMENT OF SPECIAL EXCAVATION	T	50				
203.2334	DISPOSAL/TREATMENT OF GROUNDWATER	GAL	500				
631.12	EXCAVATOR (INCLUDING OPERATOR)	HOURS	20				
613.13	BULLDOZER (INCLUDING OPERATOR)	HOURS	20				
631.172	TRUCK - LARGE (INCLUDING OPERATOR)	HOURS	20				
631.22	FRONT END LOADER (INCLUDING OPERATOR)	HOURS	20				
631.36	FOREMAN	HOURS	20				
631.37	CONSTRUCTION LABORER	HOURS	20				
800.01	VEHICLE STORAGE GARAGE	LS	1				
800.02	MOBILIZATION & DEMOBILIZATION	LS	1				
TOTAL:							

Acknowledgment is hereby made of the following Addenda received since issuance of the Plans and Specifications:

Accompanying this Proposal is an original bid bond, cashiers or certified check on _____
_____ Bank, for _____

, payable to the Maine Turnpike Authority. In case this Proposal shall be accepted by the Maine Turnpike Authority and the undersigned should fail to execute a Contract with, and furnish the security required by the Maine Turnpike Authority as set forth in the Specifications, within the time fixed therein, an amount of money equal to Five (5%) Percent of the Total Amount of the Proposal for the Contract awarded to the undersigned, but not less than \$500.00, obtained out of the original bid bond, cashier's or certified check, shall become the property of the Maine Turnpike Authority; otherwise the check will be returned to the undersigned.

The performance of said Work under this Contract will be completed during the time specified in Subsection 107.1.

It is agreed that time is of the essence of this Contract and that I (we) will, in the event of my (our) failure to complete the Work within the time limit named above, pay to Maine Turnpike Authority liquidated damages in the amount or amounts stated in the Specifications.

The undersigned is an Individual/Partnership/Corporation under the laws of the State of _____,
having principal office at _____,
thereunto duly authorized.

_____ (SEAL)

_____ (SEAL)

_____ (SEAL)

Affix Corporate Seal or Power of Attorney
Where Applicable

By: _____

Its: _____

Information below to be typed or printed where applicable:

INDIVIDUAL:

(Name)

(Address)

PARTNERSHIP - Name and Address of General Partners:

(Name)

(Address)

(Name)

(Address)

(Name)

(Address)

(Name)

(Address)

INCORPORATED COMPANY:

(President)

(Address)

(Vice-President)

(Address)

(Secretary)

(Address)

(Treasurer)

(Address)

MAINE TURNPIKE AUTHORITY

SPECIFICATIONS

PART II – SPECIAL PROVISIONS

ADDENDUM #1 4-11-24

YORK VEHICLE STORAGE GARAGE

CONTRACT 2024.09

<u>SECTION</u>	<u>TITLE</u>	<u>PAGE</u>
	GENERAL DESCRIPTION OF WORK	SP-4
	PLANS	SP-4
101.2	DEFINITION	SP-5
103.4	NOTICE OF AWARD	SP-6
104.3.8	WAGE RATES AND LABOR LAWS	SP-6
104.4.6	UTILITY COORDINATION	SP-8
104.4.6.1	TEMPORARY UTILITIES	SP-8
107.1	CONTRACT TIME AND CONTRACT COMPLETION DATE	SP-9
107.1.1	SUBSTANTIAL COMPLETION	SP-9
107.4.6	LIMITATIONS OF OPERATIONS	SP-9
203.	EXCAVATION AND EMBANKMENT	SP-11
203	EXCAVATION AND EMBANKMENT (Contaminated Soil and Groundwater Management)	SP-14
304.	AGGREGATE BASE AND SUBBASE GRAVEL	SP-20
403.	HOT MIX ASPHALT PAVEMENT	SP-21
409.	BITUMINOUS TACK COAT	SP-23
419.	SAWING AND SEALING JOINTS IN BITUMINOUS PAVEMENT (Sawing Bituminous Pavement)	SP-24
502.	STRUCTURAL CONCRETE	SP-25
603.	PIPE CULVERTS AND STORM DRAINS	SP-27

<u>SECTION</u>	<u>TITLE</u>	<u>PAGE</u>
604.	MANHOLES, INLETS AND CATCH BASINS	SP-28
605.	UNDERDRAINS	SP-30
613.	EROSION CONTROL BLANKET	SP-31
631.	EQUIPMENT RENTAL	SP-32
633.	UTILITY - PROPANE	SP-33
800.	VEHICLE STORAGE GARAGE	SP-35
800.	PROPANE TANK PADS	SP-37
822.	WATER SERVICE SUPPLY LINE	SP-38
832.	SITE BOLLARDS	SP-40

MAINE TURNPIKE AUTHORITY

SPECIFICATIONS

PART II - SPECIAL PROVISIONS

All work shall be governed by the Maine Department of Transportation Standard Specifications, Revision of November 2014, except for that work which applies to sections of the Maine Department of Transportation Standard Specifications which are amended by the Maine Turnpike Supplemental Specifications and the following modifications, additions, and deletions.

General Description of Work

NEW VEHICLE STORAGE GARAGE:

- a. The building is anticipated to be a high-bay vehicle storage garage. The main floor being a concrete slab-on-grade, and generally constructed of durable and appropriate materials. The documents indicate a pre-engineered metal building for the primary structure. Insulated metal overhead doors and personnel doors will provide access. Windows are shown as double-hung aluminum units.
- b. 6,600 SF building footprint with 6 vehicle garage bays.
 - a. Site/Civil Scope includes all site work as shown on the plans including:
 - 1) Approximately 18,000 sf paved parking and facility operation areas at the York Maintenance Yard.
 - 2) Exterior 6,000 gallon holding tank for floor drains with electrical conduit connection to existing building.
 - 3) Electrical connection from existing building DP to new building panel MDP.
 - 4) Exterior H-20 oil/water separator.
 - 5) Exterior propane tanks with connection to new building.
 - 6) Domestic service connecting the new building to the new onsite drilled well.
 - b. The pre-engineered metal building structure is clad with draped insulation roof panel assemblies for the roof and insulated metal wall panels. The exterior overhead and pass doors will be R-15 minimum. The exterior windows will be R-2.2 minimum.

Plans

The drawings included in these Contract Documents, and referred to as the Plans, show the general character of the work to be done under this Contract. They bear the general title **“Maine Turnpike – Contract 2024.09 – York Vehicle Storage Garage”**. The right is reserved by the Resident to make such minor corrections or alterations in the Plans as he deems necessary without change in the unit prices on the Schedule of Prices of the Proposal.

101.2 Definition

Holidays: The following is added after Memorial Day in the Supplemental Specifications:

Memorial Day 2024	12:01 p.m. ((Noon) preceding Friday to 6:00 a.m. the following Tuesday.
Juneteenth 2024	12:01 p.m. ((Noon) preceding Tuesday to 6:00 a.m. the following Thursday.
Independence Day 2025 (Fourth of July)	12:01 p.m. ((Noon) preceding Wednesday to 6:00 a.m. the following Friday.
Labor Day 2024	12:01 p.m. ((Noon) preceding Friday to 6:00 a.m. the following Tuesday.
Veterans Day 2024	12:01 p.m. ((Noon) preceding Friday to 6:00 a.m. the following Tuesday.
Columbus Day/Indigenous Peoples Day 2024	12:01 p.m. ((Noon) preceding Friday to 6:00 a.m. the following Tuesday.
Thanksgiving 2024	12:01 p.m. ((Noon) preceding Wednesday to 6:00 a.m. the following Monday.
Christmas Day 2024	12:01 p.m. ((Noon) preceding Tuesday to 6:00 a.m. the following Thursday.
New Year's Day 2025	12:01 p.m. (Noon) preceding Tuesday to 6:00 a.m. the following Thursday.
Martin Luther King Jr. Day 2025	12:01 p.m. ((Noon) preceding Friday to 6:00 a.m. the following Tuesday.
Presidents' Day 2025	12:01 p.m. ((Noon) preceding Friday to 6:00 a.m. the following Tuesday.
Memorial Day 2025	12:01 p.m. ((Noon) preceding Friday to 6:00 a.m. the following Tuesday.
Juneteenth 2025	12:01 p.m. ((Noon) preceding Wednesday to 6:00 a.m. the following Friday.
Independence Day 2025 (Fourth of July)	12:01 p.m.(Noon) preceding Thursday to 6:00 a.m. the following Monday.
Labor Day 2025	12:01 p.m. ((Noon) preceding Friday to 6:00 a.m. the following Tuesday.

103.4 Notice of Award

The following sentence is added:

The Maine Turnpike Authority Board is scheduled to consider the Contract Award on **April 25, 2024**.

104.3.8 Wage Rates and Labor Laws

Section 104.3.8 Wage Rates and Labor Laws has been amended as follows:

The fair minimum hourly rates determined by the State of Maine Department of Labor for this Contract are provided on the next page:

<INSERT WAGE RATES SHEET>

104.4.6 Utility Coordination

This Subsection is amended by the addition of the following:

These Special Provisions outline the arrangements which have been established by the Authority for coordination of the work to be accomplished by the utilities. The scope and schedule of utility relocation work is noted herein. The Contractor shall plan and conduct his work accordingly.

General

The contractor shall be responsible for extension of existing conduit from panel DP to new building. Provide wiring in underground conduit from existing panel DP to new building panel MDP. Connect to existing circuit breaker in panel DP.

104.4.6.1 Temporary Utilities

The Contractor will be required to maintain all services and utilities to the existing facility throughout construction. Existing services and utilities include, but are not necessarily limited to, power, telephone, water, sewer, propane, heat, and site/roadway lighting.

The Contractor shall be responsible for all temporary connections, service runs, relocation, disconnections, reconnections, etc. required to maintain these services due to phasing of construction and constraints of the site and work area. This includes any needed temporary services for the building. Temporary power can be provided on wooden poles located outside the clear zone or protected. The contractor shall coordinate with the Resident and MTA on a temporary service.

Prior to start of construction, the Contractor shall submit a plan and schedule for maintaining existing services and utilities. The plan shall identify all proposed temporary connections, service runs, relocations, disconnections, reconnections, etc. and shall reflect construction phasing and the Contractor's proposed sequence of work. Maintaining existing services and utilities and all temporary utility work, including proposed temporary connections, service runs, relocations, disconnections, reconnections, etc. shall be incidental to Contract 2024.09.

104.4.7 Cooperation with Other Contractors

- a. This subsection is amended by the addition of the following:
 - 1) Contract 2023.11 York Electrical Repairs
 - 2) Contract 2024.01 Pavement Rehabilitation Exits 1, 2, 3, MM 1.3 to MM 6.8, Spruce Creek, York River Bridge
 - 3) Contract 2024.06 York/Ogunquit Interchange Underpass MM 6.8
- b. The above construction contracts shall be considered an adjacent contract.

107.1 Contract Time and Contract Completion Date

All work for Contract 2024.09 shall be completed within 240 days of starting the work or by the following dates, whichever comes first:

- Substantial Completion: **September 19, 2025**
- Final Completion: **October 3, 2025**

MTA will entertain a start date for this work that fits within the contractor's schedule beginning after a successful MTA Board approval on April 25, 2024. Supplemental Liquidated Damages shall begin 240 days after the start date, or after the above noted Substantial Completion date, whichever comes first. Liquidated Damages shall begin 254 days after the start date, or after the above noted Final Completion date, whichever comes first.

107.1.1 Substantial Completion

This subsection is amended by the addition of the following:

Substantial completion is defined as having completed the following work:

1. Substantially completed construction of the Vehicle Storage Garage including construction of all building foundation, framing and insulation, roofing, siding, doors, and commissioning of all building electrical, mechanical, heating, and plumbing.
2. Completion of Interior finish carpentry and painting.
3. Base pavement and surface pavement have been placed to lines and grades shown on plans.

Supplemental Liquidated damages on a calendar day basis in accordance with Supplemental Specifications Subsection 107.8 shall be assessed for each calendar day that substantial completion is not achieved. The Contractor will be responsible for paying the per diem costs listed in the Supplemental Specifications Subsection 107.7.2 Schedule of Liquidated Damages for each day that substantial completion is not achieved by the specified date.

107.4.6 Limitations of Operations

Construction of the York Vehicle Storage Garage shall not interfere with Highway and Equipment Maintenance operations at any time.

The Contractor shall submit his proposed staging and storage areas for approval by the Resident. All stored equipment must be located to not interfere with Highway and Equipment maintenance operations.

Once pavement removal and regrading activities are commenced, a minimum of base pavement installation must be achieved by winter of 2024-2025.

SPECIAL PROVISION

ALL SECTIONS

GENERAL INFORMATION

~~All sections of the Maine DOT Standard Specifications (November 2014) and the Maine Turnpike Authority 2016 Supplemental Specification, not modified by other Special Provisions within this contract, shall apply with the following additions and modifications:~~

~~All Sections – Method of Measurement~~

~~These paragraphs shall be deleted in their entirety.~~

~~All Sections – Basis of Payment~~

~~These paragraphs shall be deleted in their entirety.~~

SPECIAL PROVISIONSECTION 203EXCAVATION AND EMBANKMENT

The provisions of Section 203 of the Maine DOT Standard Specifications (November 2014) and the Maine Turnpike Authority 2016 Supplemental Specification shall apply with the following additions and modifications:

203.01 Description

The following paragraph is added:

The work shall consist of cutting, removing, and disposing of the existing bituminous concrete pavement as shown on the Plans, or as approved by the owner/resident.

Common excavation shall include all excavation (over excavation) within the project limits. This shall include the complete removal and disposal of all material unsuitable for re-use on the project, existing pavement, topsoil, organics, foundations, utilities, relic materials, and structures that are located under the proposed building footprint as defined in the Geotechnical Report completed by S.W. Cole on May 27, 2020, and as noted on the Typical Sections.

During excavation if suitable material is encountered, it may be left in place or re-used on other portions of the project with approval from the resident.

Fill to raise grades, in landscaped and/or seeded areas should be non-organic compactable earth meeting the requirements of the Maine DOT Standard Specification (November 2014) 703.18 Common Borrow.

Fill to raise grades, in paved areas and in areas of backfill for over excavations, should be sand meeting the requirements of the Maine DOT Standard Specification (November 2014) 703.19 Granular Borrow for underwater backfill.

Crushed Stone as noted on the plans, used for underdrain aggregate shall be washed ¾ inch crushed stone meeting the requirements of Maine DOT Standard Specifications (November 2014) 703.22 Underdrain Backfill Material Type C.

Concrete pads to be removed as shown on the Plans.

203.04 General

The following sentence is added to the end of the third paragraph.

There are no approved waste storage areas or waste areas within the Project limits unless shown on the Plans. Unsuitable materials shall be disposed of off-site in accordance with Subsection 203.06.

All excavations shall be accomplished in accordance with the applicable OSHA Standards. The Resident reserves the right to request the Contractor to prepare an excavation plan. This plan shall include, but not necessarily be limited to, the limit and depth of excavation, side slope, shoring, trench box and utility support.

The on-site soils may be suitable for reuse as common borrow in landscaped and/or seeded areas, provided they are at a compactable moisture content at the time of reuse. Portions of the existing sandy soils may be suitable for reuse as granular borrow, provided they are free of organics and deleterious material, and are at a compactable

moisture content at the time of reuse. S.W. Cole recommends additional test pits be performed to assess suitability for reuse of existing material. Test pits to determine the suitability of existing materials will be considered incidental to the project. Relic buried organic materials are unsuitable for reuse.

203.10 Embankment Construction - General

The thirteenth and fourteenth paragraphs are deleted and replaced with the following:

All portions of the embankment shall be compacted in accordance with the designated embankment compaction requirements specified for the Project.

General Benching Requirements for proposed fills (common borrow, granular borrow, structural fill): The existing slopes should be benched prior to placing additional fill of any kind. Embankment fill of any kind should be placed in lifts which extend laterally beyond the limits of the design side slopes such that the specified degree of compaction is achieved within the limits of the completed embankment. The slopes should then be trimmed back to design dimensions.

General Compaction Requirements for proposed fills (common borrow, granular borrow, structural fill): Fill of any kind should be placed in horizontal lifts and compacted such that the desired density is achieved throughout the lift thickness with 3 to 5 passes of the compaction equipment. Loose lift thicknesses for grading, fill and backfill activities should not exceed 12 inches. S.W. Cole recommends that fill and backfill be compacted to at least 95% of its maximum dry density as determined by ASTM D-1557. Crushed Stone should be compacted with 3 to 5 passes of a vibratory plate compactor having a static weight of at least 500 pounds.

203.16 Winter Construction of Embankments

The word "core" is deleted from the first and second sentences in the first paragraph.

203.18 Method of Measurement

These paragraphs shall be deleted in their entirety and replaced with the following:

The costs for over excavation related to the removal of uncontrolled or unsuitable material encountered below building footprint as defined in the Geotech report and as directed by the Resident, shall be paid at the unit price of Pay Item 203.20 Common Excavation.

The costs for additional fill related to the removal of uncontrolled or unsuitable material encountered below building footprint as defined in the Geotech report and as directed by the Resident, shall be paid at the unit price of Pay Item 203.25 Granular Borrow.

203.19 Basis of Payment

These paragraphs shall be deleted in their entirety and replaced with the following:

All work under Section 203, Excavation and Embankment, shall be paid for as part of the lump sum bid for the project.

If the Resident determines that additional excavation is necessary, the excavation shall be paid for under Item 203.20 Common Excavation at the contract unit price per 50 cubic yards.

If the Resident determines that additional fill is necessary, the fill shall be paid for under Item 203.25 Granular Borrow at the contract unit price per 50 cubic yards.

Payment will be made under:

Pay Item

Pay Unit

203.20 Common Excavation

Cubic Yards

203.25 Granular Borrow

Cubic Yards

SPECIAL PROVISIONSECTION 203EXCAVATION AND EMBANKMENT

(Contaminated Soil and Groundwater Management)

203.01 General

Contaminated Soil and Groundwater is not known to be present within the project limits. Unanticipated soil and groundwater contamination, if encountered, shall be managed in accordance with this Specification.

The work under this Specification shall be performed in conformance with the procedures and requirements described herein for the following activities: contaminated soil handling, reuse, temporary stockpiling, transportation, storage and disposal and contaminated water handling, storage, treatment, and disposal. This Specification also addresses contaminated soil location, identification and classification. The intent of this Specification is to ensure that contaminated soil and/or water encountered during construction will be managed in a manner that protects worker health and safety, public welfare and the environment.

203.02 Unanticipated Contamination

If the Contractor encounters previously undiscovered contamination or potentially hazardous conditions related to contamination, the Contractor shall suspend work and secure the area. The Contractor will then notify the Resident immediately. The Resident will then notify the Authority. Potentially hazardous conditions include, but are not limited to, buried containers, drums, tanks, oil saturated soils, strong odors, or the presence of petroleum sufficient to cause a sheen on the groundwater. The area of potential hazard shall be secured to minimize health risks to workers and the public and to prevent a release of contaminants into the environment. The source of the suspected contamination will be evaluated by the Resident (or MTA Environmental representative). As appropriate, the Resident will notify the Maine Department of Environmental Protection's Response Services Unit in Augusta and the Authority's Environmental Services Coordinator. The Contractor will evaluate the impact of the hazard on construction, Prepare a Health and Safety Plan (HASP) and, with the Resident's approval, restart work in accordance with the procedures of this Special Provision.

203.03 General Procedure for Excavating Contaminated Soils and Groundwater

- The MTA and Resident Engineer will engage an environmental professional including a Maine Certified Geologist to oversee facility removal work, provide field screening services with a Photo-Ionization Detector (PID) and oleophilic dye tests in accordance with DEP SOP TS004, and prepare appropriate UST closure reports for MTA to submit to DEP in accordance with Chapter 691.
- The Contractor shall assume any groundwater encountered during excavation is contaminated and properly containerize and dispose of the groundwater offsite at a licensed disposal facility.

- Based on field screening results, the Contractor shall segregate soils for reuse onsite or offsite disposal. In accordance with TS004, the following criteria shall be used to characterize soils (based on using a MiniRAE PID):
 - Soils for unrestricted reuse (i.e. “clean” soil)
 - Any soil with no visual indications of contamination
 - Any soil with an oleophilic dye test yielding a “negative” result, and
 - Any soil with a PID reading less than 40 parts per million (ppm), i.e. the leaching to groundwater field screening guideline
 - Lightly contaminated soil
 - Any soil with slight discoloration related to contamination
 - Any soil with an oleophilic dye test yielding a “positive or slightly positive” result
 - Any soil with a PID reading exceeding 40 ppm but less than 1,500 ppm
 - Highly contaminated or petroleum saturated soil
 - Any soil with visible gross contamination
 - Any soil with an oleophilic dye test yielding a “saturated” result
 - Any soil with a PID reading exceeding 1,500 ppm

The field screening guidelines may be adjusted by the Resident and their environmental planner using TS004 based on the PID instrument in use:

Table 1: Approved PID Field Cleanup and Notification Guidelines

Cleanup Scenario	Soil size [grams]	Ion	Thermo	Passport	Foxboro	MiniRAE	Photon
Leaching to GW/ Notification	200	80	60	60	50	40	40
Resident/ Park User	20	700	275	500	250	350	300
Outdoor Commercial Worker/ Excavation-Construction Worker	5	1200	500	850	375	1500	400

Note: No adjustment is made for set points; the response factor should be 1.0 for all instruments.

Based on these characterizations, the following soil management practices shall be employed:

- Soil characterized for unrestricted use can be relocated and reused as general construction material anywhere at the maintenance yard. If excess soil is generated that cannot be reused this soil should be appropriately evaluated and/or sampled for laboratory analysis prior to reuse.
- Soil characterized as lightly contaminated should be properly stockpiled, covered, and managed as a contaminated material, but can be reused in the vicinity of the foundation removal and this project’s borrow needs. Any excess lightly contaminated soil that is not to be reused should be properly characterized and disposed or recycled offsite.

- Soil characterized as highly contaminated or petroleum saturated should either be live loaded or temporarily stockpiled until sufficient volume has been accumulated and shipped offsite for proper disposal or recycling. The Contractor may request Resident approval for on-site reuse of this material. A final determination will be made in concert with the MTA and MaineDEP Project Manager as to the level of contamination.
- Stockpiled contaminated soils shall be placed on an impervious surface atop polyethylene sheeting, be properly covered with poly sheeting at the end of each work day or during inclement weather, and appropriate erosion/sedimentation controls should be used in the vicinity of the stockpiles to prevent stormwater from leaching or washing contaminants to nearby impervious surfaces or stormwater management systems.

The Authority's designated representative is responsible for signing any manifests or bills of lading required to transport and dispose of contaminated soil. All documentation and paperwork associated with the transport and disposal of lightly or highly contaminated soils (i.e., manifests/bills of lading, weigh slips, invoices, permits, etc.) shall be forwarded to the Maine Turnpike Authority's Environmental Services Coordinator at 2360 Congress Street, Portland, Maine 04102 within 30 days of the last shipment of soil to the licensed facility.

203.04 Secured Stockpile Area

Should the Contractor utilize a Temporary Secured Stockpile Area (hereafter referred to as a "Secured Stockpile"), they shall install a continuous one-foot (0.30 m) high compacted soil berm around the Secured Stockpile (see Secured Stockpile Area – Materials below for Specifications pertaining to soil berm, liner, cover and barricades). The Secured Stockpile shall be placed on a liner of 20-mil polyethylene and securely covered with 20-mil polyethylene. The polyethylene liner and cover shall be placed over the soil berm and be installed to ensure that precipitation water drains directly to the outside of the berm perimeter while leachate from the contaminated soil is retained within the stockpile by covering with a polyethylene. The Secured Stockpile and soil berm shall be enclosed within a perimeter of temporary concrete barriers or security fence. The area within the temporary concrete barriers (or security fence) shall be identified as a "restricted area" to prevent unauthorized access to the contaminated soils. The Contractor shall submit to the Resident a plan (sketch and sections) of the proposed secured stockpile area.

203.05 Secured Stockpile Area - Materials

- A. Polyethylene. Polyethylene used for liner and cover in the Secured Stockpile Area shall have a minimum of 20-mil thickness and shall meet the requirements of ASTM D3020.
- B. Common Borrow. Fill used in the construction of the Temporary Secured Stockpile Area soil berm shall consist of Common Borrow and meet the requirements of Subsection 703.18.
- C. Concrete Barriers or Security Fence. Concrete Barriers or Security Fence to form the sides of the Temporary Secured Stockpile Area shall meet the requirements of Section 526 or Subsection 607.

203.06 Health and Safety/Right-to-Know:

Contractors and subcontractors are required to notify their workers of the history of the area and contamination that may be present and to be alert for evidence of contaminated soil and groundwater. The Contractor shall notify the Resident at least 72-hours prior to commencing any excavation.

The Contractor shall prepare a site-specific Health and Safety Plan (HASP) for its workers and subcontractors who may work in the contaminated area of the site. A Qualified Health and Safety Professional shall complete the HASP. The HASP shall be submitted to the Authority in accordance with the Submittal section below. The Qualified Health and Safety Professional will be an expert in field implementation of the following federal regulations:

29 CFR 1910.120 or Hazardous Waste Operations, and 29 CFR 1926.65 Emergency Response

29 CFR 1910.134 Respiratory Protection 29 CFR

1926.650 Subpart D - Excavations 29 CFR

1926.651 General Requirements

29 CFR 1926.652 Requirements for Protective Systems

The Contractor shall designate a person to provide direct on-site supervision of the work in the contaminated area. This person shall have the training and medical surveillance under OSHA 1910.120 (e) and (f) respectively, as detailed above and in addition be qualified as a construction Competent Person [OSHA 1926.32 (f) and (l)]. It is the responsibility of this designated person to make those inspections necessary to identify situations that could result in hazardous conditions (e.g., possible cave-ins, indications of failure of protective systems, hazardous atmospheres, or other hazardous conditions), and then to ensure that corrective measures are taken.

Work inside contaminated trench sections may be subject to OSHA's permit-required confined space regulations under 29 CFR 1910.146.

Submittals. If contaminated soils are encountered the Contractor shall prepare and submit a site specific Health and Safety Plan (HASP) to the Resident for review, and receive approval, prior to completing any additional excavation work in the vicinity of the contaminated area. The Maine Turnpike and its Environmental Services Coordinator will review and comment on the HASP within five business days.

Health and Safety Monitoring. Within the contaminated area of the Project, the Contractor's designated person shall monitor the worker breathing zone for those constituents specified in the Contractor's HASP. The Contractor shall provide all required health and safety monitoring equipment.

203.07 Dewatering

Groundwater may be encountered during excavation for the foundation and utility work. If encountered and should its removal become necessary to complete work, it will be treated as

“contaminated” water. The Contractor shall inform the Resident before any dewatering commences. The “contaminated” water shall be pumped into a temporary holding tank(s). The Contractor will be responsible for the procurement of any holding tank(s). Any testing, treatment and/or disposal of the stored, petroleum contaminated water shall be undertaken by the Contractor in accordance with applicable Federal, State and local regulatory requirements.

203.08 On-Site Water Storage Tanks - Materials

If dewatering within the identified contaminated area becomes necessary the holding tanks used for temporary storage of contaminated water pumped from excavations shall be contamination-free and sized appropriately for Contractor’s storage, treatment, and disposal process.

203.09 Dust Control

The Contractor shall employ dust control measures to minimize the creation of airborne dust during construction within the contaminated area. As a minimum, standard dust control techniques shall be employed where heavy equipment and the public will be traveling. These may include techniques such as watering-down the site or spreading hygroscopic salts.

203.10 Method of Measurement

This work will be measured for payment as appropriate, and as approved by the Resident, if potentially contaminated soils are encountered on site.

Health and Safety Plan (HASP) will be measured for payment by the Lump Sum.

Disposal/Treatment of Special Excavation will be measured for payment by the Ton.

Disposal/Treatment of Groundwater will be measured for payment by the Gallon.

203.11 Basis of Payment

Health and Safety Plan (HASP) shall be paid for as part of the lump sum bid for the project.

Disposal/Treatment of Special Excavation (contaminated soils) will be paid for at the Contract unit price per Ton which payment shall be full compensation for excavating, loading, hauling, treatment, placing, grading, and compacting, and all necessary equipment and labor. Only soil excavated from within the area shown on the plans or as designated by the Resident will be paid under this pay item.

Disposal/Treatment of Contaminated Groundwater will be paid for at the Contract unit price per Gallon which payment shall be full compensation for pumping excavations, loading hauling, treatment, and all necessary equipment and labor. Only groundwater pumped, treated and disposed of properly from the site will be paid under this pay item. Any water that is not required to be treated will not be paid for. Contractor is to propose and submit for review measurement and calibration of meter for pumped water.

There will be no measurement for identification and environmental screening of contaminated soil material or groundwater (this will be done by the Resident or Authority’s Environmental Services Coordinator).

Construction of a Temporary Secured Stockpile Area, or groundwater holding tank, if necessary, will not be measured separately for payment, but shall be incidental to Items 203.2312, 203.2333, and 203.2334.

Hauling Surplus contaminated soils to the Temporary Secure Stockpile area or placement and removal of contaminated soils in or out of the Temporary Secure Stockpile area will not be measured separately for payment, but shall be incidental to Items 203.2312, 203.2333, and 203.2334.

All hauling and any subsequent management/placement of contaminated soils and/or groundwater shall be incidental to Items 203.2312, 203.2333, and 203.2334.

There will be no separate measurement for additional laboratory testing of contaminated soil that is required by the landfill or treatment facility. Testing shall be incidental to Item 203.2333, and 203.2334.

Payment will be made under:

<u>Pay Item</u>		<u>Pay Unit</u>
203.2333	Disposal/Treatment of Special Excavation	Ton
203.2334	Disposal/Treatment of Groundwater	Gallon
203.2312	Health and Safety Plan	LS

SPECIAL PROVISIONSECTION 304AGGREGATE BASE AND SUBBASE COURSES

The provisions of Section 304 of the Maine DOT Standard Specifications (November 2014) and the Maine Turnpike Authority 2016 Supplemental Specification shall apply with the following additions and modifications:

304.02 General

Sources of Aggregate and preliminary test results shall be submitted ten working days prior to any placement of material on the job. Failure of these preliminary tests will be grounds for rejection of material from that source. Aggregates will be tested on the job and shall meet these specifications as the material is incorporated into the work.

Back fill for foundations, slab base material and material below the footings and exterior entrance slabs and within the frost transition zone as shown in the typical sections should be clean, non-frost susceptible sand and gravel meeting the gradation requirements for structural fill.

Structural Fill	
Sieve Size	Percent Finer by Weight
4 inch	100
3 inch	90 to 100
¼ inch	25 to 90
No. 40	0 to 30
No. 200	0 to 6

304.06 Method of Measurement

These paragraphs shall be deleted in their entirety.

304.07 Basis of Payment

These paragraphs shall be deleted in their entirety and replaced with the following:

All work under Section 304, Aggregate Base and Subbase Course, shall be paid for as part of the lump sum bid for the project.

The costs for laboratory testing and source documentation shall be incidental to the project. The costs for all failing tests shall be the responsibility of the contractor.

No additional payment will be made for the temporary placement of gravels during construction.

SPECIAL PROVISIONSECTION 403HOT MIX ASPHALT PAVEMENT

The provisions of Section 403 of the Maine DOT Standard Specifications (November 2014) and the Maine Turnpike Authority 2016 Supplemental Specification shall apply with the following additions and modifications:

Project Pavement

Course	HMA Grading	Item Number	Total Thickness	No. of Layers	Complimentary Notes
Base	19.0mm	403.207	2 ½”	1	C,I
Wearing	12.5mm	403.208	1 ½”	1	C,I

COMPLEMENTARY NOTES

- A. The required PGAB for this mixture shall be **64E-28**.
- B. RAP may not be used.
- C. The MTA will conduct the job mix verification. The aggregate qualities shall meet the design traffic level of 3 to <10 million ESALS for mix placed under this contract. Minimum and Maximum PGAB content limits from 401.21 shall not apply.
- D. The MTA will conduct the job mix verification. The aggregate qualities shall meet the design traffic level of 10 to <30 million ESALS for mix placed under this contract. The design verification, Quality Control, and Acceptance tests for this mix will be performed at **75 gyrations**. (N design)
- E. A material transfer vehicle (MTV) shall be used for the placement of Hot Mix Asphalt wearing surface on all roadways including acceleration and deceleration lanes and all ramps.
- F. Joints shall be constructed as the “notched wedge” type in accordance with Subsection 401.17.
- G. Joint density will be measured in accordance with Subsection 401.165.
- H. PGAB shall conform to the provisions of 403.02 – Polymer Modified PGAB for HMA
- I. The contractor shall furnish a quality control technician equipped with an approved densometer to ensure density requirements are met.
- J. Hydrated Lime shall be incorporated into the mixture.
- K. The antistripping additive Zycotherm manufactured by Zydex Industries shall be incorporated into the PGAB at a rate of 0.1%.

403.04 Method of Measurement

These paragraphs shall be deleted in their entirety.

403.05 Basis of Payment

These paragraphs shall be deleted in their entirety and replaced with the following:

All work under Section 403, Hot Mix Asphalt Pavement, shall be paid for as part of the lump sum bid for the project.

SPECIAL PROVISIONSECTION 409BITUMINOUS TACK COAT

The provisions of Section 409 of the Maine DOT Standard Specifications (November 2014) and the Maine Turnpike Authority 2016 Supplemental Specification shall apply with the following additions and modifications:

409.01 Description

This Subsection is deleted and replaced with the following:

This work consists of furnishing and applying one uniform application of RS-1 or RS-1h tack or an approved equal as indicated in this specification and as per manufacturers' recommendation. The application rate shall be 0.06 gal/yd².

A tack coat is required between pavement lifts as well as on all sawcut butt joints.

409.05 Equipment

Add "or as determined by the Resident", after the words "gal/yd²]" in the fourth line of the second paragraph of this Subsection.

409.06 Preparation of Surface

The following paragraph is added:

All existing pavement and shoulder areas on which bituminous concrete mixtures are to be placed shall receive a tack coat. The surface area where the tack coat is to be applied shall be dry and cleaned of all dirt, sand, and loose material. Cleaning shall be accomplished by use of revolving brooms or mechanical sweepers. Undesirable material not removed by the above means shall be cleaned by hand sweeping or scraping, or a combination of both. Small areas otherwise inaccessible may be swept with hand brooms. The tack coat shall be applied only when the existing surface is dry.

409.08 Method of Measurement

These paragraphs shall be deleted in their entirety.

409.09 Basis of Payment

These paragraphs shall be deleted in their entirety and replaced with the following:

All work under Section 409, Bituminous Tack Coat, shall be paid for as part of the lump sum bid for the project.

SPECIAL PROVISION

SECTION 419

SAWING AND SEALING JOINTS IN BITUMINOUS PAVEMENT

(Sawing Bituminous Pavement)

419.01 Description

This work consists of sawing bituminous concrete pavement as shown on the Plans, as specified herein or as approved by the Resident.

419.02 General

The bituminous concrete pavement to be sawed shall be accurately marked before cutting. The marking shall be in accordance with the locations as shown on the Plans or as approved by the Resident. Cutting shall be with an approved power-driven saw with an abrasive blade.

Unless otherwise noted or directed, the sawcut shall be vertical, a minimum of 3/8 inch wide, and extend to the depth as shown on the Plans.

Residue or debris from the sawing operation shall be removed immediately and legally disposed of by the Contractor.

419.03 Method of Measurement

These paragraphs shall be deleted in their entirety.

419.04 Basis of Payment

These paragraphs shall be deleted in their entirety and replaced with the following:

All work under Section 419, Sawing and Sealing Joints in Bituminous Pavement, shall be paid for as part of the lump sum bid for the project.

SPECIAL PROVISION

SECTION 502

STRUCTURAL CONCRETE

(Concrete Propane Tank Pad)

502.01 Description

The following paragraphs are added:

The work shall consist of designing, fabricating and installing cast-in-place or precast concrete pads for the relocated propane tanks in accordance with these Specifications and in conformity with the lines, grades, and dimensions shown on the Plans.

All work shall be completed in accordance with Supplemental Specifications, Section 502, for cast-in-place concrete, and Standard Specifications, Section 534, for precast concrete.

The design and shop drawings for each slab shall be developed and stamped by a professional engineer licensed to practice in the State of Maine and shall be submitted to the Resident for review and approval. The Contractor shall have approved shop drawings prior to beginning any construction relative to this section.

All top and vertical surfaces of the slabs shall be coated with an approved Protective Coating for Concrete Surfaces meeting the requirements of the MTA's Supplemental Specifications, Section 515.

502.02 Materials

All concrete, whether precast or cast-in-place, shall be Class "AAA" meeting the requirements of the MTA's Supplemental Specifications, Section 502.

All reinforcing steel shall be epoxy coated meeting the requirements of Standard Specification, Section 503.

All anchorages and components permanently embedded in the slabs shall be hot dip galvanized after fabrication.

502.09 Design and Construction Requirements

The following subsection is added:

The slab and anchorage designs, whether precast or cast-in-place, shall be in accordance with the provisions of Standard Specification 534, Section 534.04. A subgrade modulus of 100 pounds per cubic inch shall be used unless an alternate value is submitted and approved.

For precast components all lifting devices on the top surface of the slab shall be hot dip galvanized and recessed into the slab. The lifting device recess shall be filled with an approved non-shrink repair material approved by the Resident.

502.18 Method of Measurement

These paragraphs shall be deleted in their entirety.

502.19 Basis of Payment

These paragraphs shall be deleted in their entirety and replaced with the following:

All work under Section 502, Structural Concrete, shall be paid for as part of the lump sum bid for the project.

SPECIAL PROVISION

SECTION 603

PIPE CULVERTS AND STORM DRAINS

(PVC Pipe)

The provisions of Section 603 of the Maine DOT Standard Specifications (November 2014) and the Maine Turnpike Authority 2016 Supplemental Specification shall apply with the following additions and modifications:

603.01 Description

The following paragraphs are added:

This work shall also consist of furnishing and installing various sizes of PVC pipe. No other pipe types within the Option III alternatives will be accepted.

603.02 Materials

All Polyvinylchloride pipe for storm water and drainage systems shall meet the requirements of Subsection 706.08.

603.11 Method of Measurement

These paragraphs shall be deleted in their entirety.

603.12 Basis of Payment

These paragraphs shall be deleted in their entirety and replaced with the following:

All work under Section 603, Pipe Culverts and Storm drains, shall be paid for as part of the lump sum bid for the project.

SPECIAL PROVISIONSECTION 604MANHOLES, INLETS AND CATCH BASINS

(6,000 Gallon Holding Tank and H-20 Oil/Water Separator)

The provisions of Section 604 of the Maine DOT Standard Specifications (November 2014) and the Maine Turnpike Authority 2016 Supplemental Specification shall apply with the following additions and modifications:

604.01 Description

This work shall consist of the construction and placement of various drainage structures.

The proposed holding tank shall contain a liquid capacity of 6,000 gallons by American Concrete or equivalent. Conform to the applicable requirements of ASTM C478. Concrete compressive strength shall be 5,000 psi at 28 days. Wire fabric for reinforcement shall conform to the requirements of ASTM A185 and steel reinforcement shall conform to the requirements of ASTM A615 with a minimum yield stress of 40,000 psi.

All joints shall be sealed with Tylox superseal rubber gasket or equivalent.

The contractor shall provide a licensed tank installer for the installation (of both the Oil/Water Separator and the 6,000 gallon Holding Tank) per Maine Department of Environmental Protection requirements.

If required, the Contractor is responsible for submitting all required paperwork to the Maine Turnpike Authority prior to filing with the Maine DEP.

Shop drawings for both the 6,000-gallon holding tank and the H-20 Oil/Water Separator shall be completed, submitted to, and accepted by the Resident prior to any work being completed relative to these items.

604.011 Oil/Water Separator Description:

The Contractor shall submit a shop drawing to the resident for approval for Item 604.159 Utility Vault (H-20 Oil/Water Separator) which shall meet the requirements listed herein:

- The Oil/Water separator shall perform its intended function and have pipe inlets/outlets within reasonable conformity with the special grading detail shown in the contract documents.
- The Oil/Water Separator shall have an approximate maximum volume of 400-500 gallons.
- Provide 30" diameter frame and cover on top of the structure with shiplap joints.
- Concrete: 5,000 PSI @ 28 days.
- Cement shall be type III per ASTM C150-81
- Reinforcing: Grade 60 Per ASTM A615.
- Design Loading: H-20 per ASTM C-478.
- Joints to be sealed watertight with Con-seal.
- Provide inlet/outlet pipe boots to fit 6" PVC pipe.
- Sealant inside or outside of the structure for waterproofing the concrete other than joints.

Example Oil/Water Separator that meets the requirements listed above:

- The George R. Roberts H-20 Oil/Water Separator.

604.02 Materials

Frame and Cover for Manhole and Holding tank shall be Neenah R-1156A or equivalent.

The frame, cover, and risers shall all be 30" in diameter for the 6,000-gallon holding tank as well as the H-20 oil/water separator.

The 18" manhole on the holding tank shall be Universal Multipurpose Manhole Model 98-1810 or approved equal.

604.05 Method of Measurement

These paragraphs shall be deleted in their entirety.

604.06 Basis of Payment

These paragraphs shall be deleted in their entirety and replaced with the following:

All work under Section 604, Manholes, Inlets, and Catch Basins, shall be paid for as part of the lump sum bid for the project.

SPECIAL PROVISION

SECTION 605

UNDERDRAINS
(4" Foundation Drains)

The provisions of Section 605 of the Maine DOT Standard Specifications (November 2014) and the Maine Turnpike Authority 2016 Supplemental Specification shall apply with the following additions and modifications:

605.01 Description

This work shall consist of the construction and placement of an underdrain system to be installed on the outside edge of perimeter footings as well as the drainpipe that outlets on the Northeast side slope of the building. The underdrain pipe should consist of 4-inch diameter, perforated SDR-35 foundation drainpipe bedded in Crushed Stone and wrapped in non-woven geotextile fabric. The underdrain pipe must have a positive gravity outlet protected from freezing, clogging and backflow. Surface grades should be sloped away from the building for positive surface water drainage. General underdrain details are illustrated on the "Foundation Detail Sketch" in the Explorations and Geotechnical Engineering Services Report completed by S.W. Cole Engineering.

605.02 Materials

The material used for all 4" Foundation Drains shall be perforated SDR-35.

605.06 Method of Measurement

These paragraphs shall be deleted in their entirety.

605.07 Basis of Payment

These paragraphs shall be deleted in their entirety and replaced with the following:

All work under Section 605, Underdrains, shall be paid for as part of the lump sum bid for the project.

SPECIAL PROVISION

SECTION 613

EROSION CONTROL BLANKET

The provisions of Section 613 of the Maine DOT Standard Specifications (November 2014) and the Maine Turnpike Authority 2016 Supplemental Specification shall apply with the following additions and modifications:

613.01 Description

This work shall also include seeding, mulching, and watering the side slopes and non-impervious areas as shown on the plans or directed by the Owner.

The following sentences are added:

Seeding shall meet the requirements of Section 618, Seeding, Method Number 2. Mulch shall meet the requirements of Section 619.

613.02 Materials

The following Subsection is added: 613.041 Maintenance and Acceptance

See Section 618.10 for maintenance and acceptance of seeding.

613.042 Mulch

All mulch shall be placed after the area has been seeded and prior to the installation of the Erosion Control Blanket.

613.08 Method of Measurement

These paragraphs shall be deleted in their entirety.

613.09 Basis of Payment

These paragraphs shall be deleted in their entirety and replaced with the following:

All work under Section 613, Stone Fill, Riprap, Stone Blanket, and Stone Ditch Protection, shall be paid for as part of the lump sum bid for the project.

SPECIAL PROVISION

SECTION 631

EQUIPMENT RENTAL

The provisions of Section 631 of the Standard Specifications shall apply with the following additions and modifications:

These items will only be used at the discretion of the Authority’s Representative.

627.08 Basis of Payment

Payment will be made under:

Pay Item		Pay Unit
631.12	All Purpose Excavator (Including Operator)	Hour
631.13	Bulldozer (Including Operator)	Hour
631.172	Truck – Large (Including Operator)	Hour
631.22	Front End Loader (Including Operator)	Hour
631.36	Foreman	Hour
631.37	Laborer	Hour

SPECIAL PROVISIONSECTION 633UTILITY – PROPANE(Propane System)633.01 DescriptionNew Propane Tanks

Work shall include the connection/hookup and installation of propane gas service from the propane tanks (noted on the plans) to the proposed 6-bay maintenance garage. This work will include excavating, hauling, disposing, backfilling, and compacting of all materials for the construction of the proposed utility trench in reasonably close conformity with the lines, grades, thickness, and details shown on the Plans. This work shall also include laying the pipe, installing all fittings and valves, testing the system, and connecting to the proposed maintenance garage. The contractor shall install a complete and functioning system as approved by the MTA propane supplier.

General Information

Propane tanks, unless otherwise specified on the plans, shall be supplied by the Contractor and shall be new.

The contractor shall be responsible for the installation of all propane tanks and all propane lines.

The contractor shall coordinate this work with the MTA propane supplier. The MTA propane supplier shall inspect and accept the lines that have been installed prior to backfilling the trenches.

633.02 Materials

The Propane Service Line shall be ½” HDPE distribution pipe meeting the requirements of ASTM D2513. Tracer wire shall be installed in all service trenches in accordance with the detail provided in the Plans.

Backfilling shall consist of placing suitable material in all spaces excavated and not occupied by the utility lines up to the loam and/or pavement subbase elevation. Backfill shall be excavated material or select backfill as directed by the engineer, placed at or near optimum moisture content and shall not contain stones larger than three inches, frozen lumps, chunks of clay, organic matter, or other objectionable material.

Sand borrow bedding material shall meet the requirements of Subsection 703.01.

Tanks shall use American Welding and ASME Tank or approved equal.

633.03 Construction

The Contractor shall coordinate the construction of the utility trench with the Authority’s propane supplier, and the resident/inspector. Backfill shall be in accordance with Section 206, Structural Excavation. Propane gas lines shall be furnished, installed, and tested by the Contractor. The Authority’s propane gas supplier shall inspect the lines prior to backfilling. Excavation, bedding and backfill shall be completed by the Contractor. The Contractor is required to give a 10-day notice to the MTA/Propane supplier for inspection.

Warning tapes shall be a metallic/detectable type made of solid yellow film with continuously printed black-letter caption: "CAUTION—PROPANE GAS BURIED BELOW". The warning tape shall be acid and alkali-resistant polyethylene film warning tape manufactured for marking and identifying underground utilities, six inches wide and four mils thick, continuously inscribed with a description of the utility.

633.04 Method of Measurement

These paragraphs shall be deleted in their entirety.

633.05 Basis of Payment

These paragraphs shall be deleted in their entirety and replaced with the following:

All work under Section 633, Utility-Propane, shall be paid for as part of the lump sum bid for the project.

SPECIAL PROVISIONSECTION 800Vehicle Storage Garage800.1 Description

Division 800 specifies materials, procedures, and requirements for the construction of the York Vehicle Storage Garage, complete with all appurtenances, including any and all associated utilities and services within the limits as shown on the Drawings.

The Contractor shall submit to the Resident for approval a cost breakdown of the major components of work for the York Vehicle Storage Garage by standard specification Division lines items from 01 to 41. This breakdown will be used as a basis for monthly pay estimates.

A building walk-thru shall occur 30 days prior to anticipated completion of the building. Contractor shall allow the MTA access to the new building to furnish and install necessary equipment for toll operations. This shall be one week prior to the completion of the building.

The Contractor shall ensure and be responsible for the total and complete coordination of all work in the York Vehicle Storage Garage. The Contractor shall generate coordination drawings for the Building. Coordination drawings shall:

1. Be computer generated.
2. Show a dimensionally accurate representation of all equipment that was approved by the shop drawing process.
3. Show architectural features, structural features, piping, conduit, ductwork, and any other items that require coordination which shall be accurately sized.
4. Be submitted to and approved by the MTA prior to the purchasing of any approved equipment.

800.2 Work Included

The work consists of the following:

1. Construction of an approximate 6,600 square foot pre-engineered building consisting of six (6) equipment storage garage bays.

Construction includes, but is not necessarily limited to, the following:

- The work includes all building structure, mechanical, electrical, and plumbing, as well as all site work, grading, pavement, lighting, utilities, and all other work incidental thereto in accordance with the Plans and Specifications.
- Excavating, filling, and backfilling for building utilities, services, foundations.
- Construction of reinforced concrete footings, pier, foundation walls, and slabs-on-grade including exterior concrete aprons and entry foundation/slab systems.

- Construction of the Garage proper, including all equipment and interior and exterior finishes.
- Furnishing and installing plumbing, heating, electrical, and telephone, complete with all appurtenances and accessories.
- Provide feeder to panel MDP from existing panel DP. Provide wiring in existing underground conduit. Extend existing underground conduit to building.

Note: The conduits outside of these limits for service tie between the stubbed-out service point into the new Vehicle Storage Building are included in this Division pay item.

800.3 Method of Measurement

The York Vehicle Storage Garage will be measured for payment by the lump sum, complete and accepted.

~~The horizontal pay limit shall be within 5 feet of the defined perimeter of the building, entries, and concrete aprons. The vertical pay limit for this work shall be above the bottom of footing level or bottom of footing subbase, if required.~~

~~All work within this pay limit, including utilities, excavation, backfilling, etc., will be included in this pay item. Work outside of the horizontal pay limit shall be performed under other portions of the Contract documents with the exception of:~~

- ~~• All excavations and fill for footings and slab are included in the pay item for beneath the building footprint and out 5' beyond the limits of the foundation footings.~~

The work described above shall be included in the building pay item.

800.4 Basis of Payment

Building construction will be paid for at the lump sum price bid which shall be full compensation for the cost of furnishing all materials, equipment, supplies, tools, incidentals, labor and supervision necessary to satisfactorily complete the work in all respects, to the satisfaction of the Resident.

Mobilization shall not be within the lump sum pay limit but will be paid for and meet the specifications of pay item 659.10.

Payment will be made under:

<u>Pay Item</u>		<u>Pay Unit</u>
800.01	York Vehicle Storage Garage	Lump Sum
800.02	Mobilization & Demobilization	Lump Sum

SPECIAL PROVISIONS

SECTION 800

Concrete Pads
(Propane Tank Pad)

800.01 Description

This work shall consist of installing precast concrete propane tank pads for proposed propane tanks as detailed in the project and these specifications.

Shop drawings for the Precast Concrete Propane Tank Pads shall be stamped by a professional engineer and submitted to the Resident and the MTA for review/approval. The contractor must have approved shop drawings prior to any work being completed relative to this section.

800.02 Materials

Concrete shall be Class "A" concrete (4000 PSI) and shall meet the requirements of Section 502.

Reinforcing steel shall meet the requirements of Section 503.

800.03 Method of Measurement

These paragraphs shall be deleted in their entirety.

800.04 Basis of Payment

These paragraphs shall be deleted in their entirety and replaced with the following:

All work under Section 800, Concrete Pads, shall be paid for as part of the lump sum bid for the project.

SPECIAL PROVISIONS

SECTION 822

WATER SERVICE SUPPLY
(1", 1 ¼", 2" Water Service)

822.01 Description

This work shall consist of installing water service supply lines in reasonably close conformity with the lines and grades shown on the plans or established. The installation shall include the assembly of all components and materials shown on the plans or as directed.

822.02 General

The work in this Section shall also include the following:

- Furnishing and installation of pipe, tubing, valves, service boxes, fittings, insulation, tapping, and any required accessories for a complete water service supply.
- Connection to proposed well system.
- Testing.

822.03 Materials

Water Service Supply Lines

Water service supply lines shall be high density polyethylene plastic tubing and conform to AWWA standard C901-02 (PE 3608 Pressure Class 200), ASTM D3350, ASTM D2737 and be clearly marked. The product shall be rated for a minimum 200 working PSI and the standard dimension ratio (SDR) shall not exceed 9 for tubing size.

Tubing shall be approved for potable water service by the National Sanitation Foundation (NSF) and bear the NSF seal. Stainless steel inserts shall be used at all connections.

Necessary fittings, adaptors and reducers shall be furnished as required.

Fittings

All fittings shall be compression type, designed for use with high density polyethylene plastic tubing (CTS).

Bedding

Bedding material for water service supply lines shall be screened sand consisting of clean, inert, hard, durable grains of quartz or other hard, durable rock, free from loam, clay, surface coatings, frozen or deleterious materials and in conformance with the following gradation:

<u>Sieve (ASTM D422)</u>	<u>Percent Passing by Weight</u>
No. 4	100
No. 8	80 - 95
No. 16	55 - 85
No. 50	0 - 35
No. 200	0 - 5

Bedding material for water service supply lines shall be compacted to a minimum of 92% of the laboratory derived Maximum Density Values at optimum moisture content as determined by ASTM D1557, Method C.

822.04 Installation Service Pipe

Care shall be exercised in placing and laying of services to prevent kinks or sharp bends and to prevent contact with sharp stones or ledge which would damage to the pipe. At least 6 inches of sand shall be placed adjacent to, under, and above the pipe, and no stone larger than 2 inches shall be placed over the pipe until the depth of backfill above the pipe is in excess of 1 foot.

Separation from Structures

Whenever possible, water pipes shall maintain a minimum distance of three (3) feet from underground adjacent unheated structures, such as manholes, catch basins, retaining walls, bridge abutments, parking garages, etc.

When spacing described above is not possible, Contractor shall provide insulation for the water pipe for a minimum of three (3) feet beyond the limits of the adjacent structure.

Testing

Hydrostatic pressure and leakage test shall be conducted in accordance with AWWA Standard C600 Standards. Testing shall be conducted by a certified independent water testing company.

Flushing the System

Before the pipe is placed into service and is accepted for payment, the Contractor shall flush the pipe at a minimum rate of 6 gallons per minute for 15 minutes or until the water is clean and free from discoloration and or debris whichever is longer. The contractor shall coordinate with the resident and MTA to ensure that they are on site during this process to ensure the water is clear of debris prior to accepting the work.

822.05 Method of Measurement

These paragraphs shall be deleted in their entirety.

822.06 Basis of Payment

These paragraphs shall be deleted in their entirety and replaced with the following: All work under Section 822, Water Service Supply Line, shall be paid for as part of the lump sum bid for the project.

SPECIAL PROVISION

SECTION 832

SITE BOLLARDS

832.01 Description

This work shall consist of furnishing and installing Type A Steel Site Bollards with cast in place concrete base with a chamfer edge, 6" schedule 80 steel pipe filled with concrete, and plastic yellow sleeve in accordance with these specifications, and as shown on the Plans.

Shop drawings for the bollards shall be completed, submitted to and accepted by the Resident prior to any work being completed relative to this item.

832.02 Materials

Concrete shall be Class "A" concrete (3000 PSI) and shall meet the requirements of Section 502.

Yellow sleeves are available from the sources noted on the plans or an approved equal.

832.03 Method of Measurement

These paragraphs shall be deleted in their entirety.

832.04 Basis of Payment

These paragraphs shall be deleted in their entirety and replaced with the following:

All work under Section 832, Site Bollards, shall be paid for as part of the lump sum bid for the project.

SECTION 220533 - HEAT TRACING FOR PLUMBING PIPING

PART 1 - GENERAL

1.1 SUMMARY

- A. Section includes heat tracing of plumbing piping for domestic hot-water-temperature maintenance with self-regulating, parallel-resistance electric heating cables:
- B. Related Requirements:

1.2 ACTION SUBMITTALS

- A. Product Data: For each type of product.
 - 1. Include rated capacities, operating characteristics, and furnished specialties and accessories.
 - 2. Schedule heating capacity, length of cable, spacing, and electrical power requirement for each electric heating cable required.
- B. Shop Drawings: For electric heating cable.
 - 1. Include plans, elevations, sections, and attachment details.
 - 2. Include diagrams for power, signal, and control wiring.

1.3 INFORMATIONAL SUBMITTALS

- A. Field quality-control reports.
- B. Sample warranties.

1.4 CLOSEOUT SUBMITTALS

- A. Operation and Maintenance Data: For electric heating cables and controls to include in operation and maintenance manuals.

1.5 WARRANTY

- A. Special Warranty: Manufacturer agrees to repair or replace electric heating cable that fails in materials or workmanship within specified warranty period.
 - 1. Warranty Period: Three years from date of Substantial Completion.

PART 2 - PRODUCTS

2.1 SELF-REGULATING, PARALLEL-RESISTANCE HEATING CABLES

- A. Manufacturers: Subject to compliance with requirements, provide products by one of the following:
 - 1. Chromalox, Inc.
 - 2. Delta-Therm Corporation.
 - 3. RAYCHEM; brand of nVent Electrical plc.
- B. Source Limitations: Obtain all heat tracing from one manufacturer.
- C. Standard: IEEE 515.1.
- D. Heating Element: Pair of parallel No. 16 AWG, tinned, stranded copper bus wires embedded in crosslinked conductive polymer core, which varies heat output in response to temperature along its length.
- E. Electrical Insulating Jacket: Flame-retardant polyolefin.
- F. Grounding Cover: Copper braid.
- G. Cable Cover: Polyolefin outer jacket with ultraviolet inhibitor.
- H. Terminate cable with waterproof, factory-assembled, nonheating leads with connectors at one end, and seal the opposite end watertight. Cable is to be capable of crossing over itself once without overheating.
- I. Maximum Operating Temperature (Power On): 150 deg F (65 deg C).
- J. Maximum Exposure Temperature (Power Off): 185 deg F (85 deg C).
- K. Electrical Components, Devices, and Accessories: Listed and labeled as defined in NFPA 70 by a qualified testing agency, and marked for intended location and application.
- L. Capacities and Characteristics:
 - 1. Maximum Heat Output: 8 W/ft. (26 W/m).
 - 2. Piping Diameter: As shown on the drawings.
 - 3. Electrical Characteristics for Single-Circuit Connection:
 - a. Volts: 120 V.
 - b. Phase: 1.
 - c. Hertz: 60.

2.2 CONTROLS

1. Remote temperature sensor senses domestic hot water temperature: programmable to control the domestic hot water temperature at 110 to 120 deg F (47 to 53 deg C).
2. Corrosion-proof and waterproof enclosure suitable for outdoor mounting, for controls and temperature sensors.
3. Minimum 30 A contactor to energize cable or close other contactors.
4. Ground-fault protection.
5. Single-point control of heat tracing for domestic hot-water-temperature maintenance.

B. Programmable Timer for Domestic Hot-Water-Temperature Maintenance:

1. Microprocessor based.
2. Minimum of four separate schedules.
3. Minimum 24-hour battery carryover.
4. On-off-auto switch.
5. 365-day calendar with 20 programmable holidays.
6. Relays with contacts to indicate operational status, on or off, and for interface with central HVAC-control system.

2.3 ACCESSORIES

- A. Cable Installation Accessories: Fiberglass tape, heat-conductive putty, cable ties, silicone end seals and splice kits, and installation clips all furnished by manufacturer, or as recommended in writing by manufacturer.
- B. Warning Tape: Continuously printed "Electrical Tracing"; vinyl, at least 3 mils (0.08 mm) thick, and with pressure-sensitive, permanent, waterproof, self-adhesive back.
 1. Width for Markers on Pipes with OD, Including Insulation, Less Than 6 Inches (150 mm): 3/4 inch (19 mm) minimum.
 2. Width for Markers on Pipes with OD, Including Insulation, 6 Inches (150 mm) or Larger: 1-1/2 inches (38 mm) minimum.

PART 3 - EXECUTION

3.1 EXAMINATION

- A. Examine surfaces and substrates to receive electric heating cables for compliance with requirements for installation tolerances and other conditions affecting performance.
 1. Ensure surfaces and pipes in contact with electric heating cables are free of burrs and sharp protrusions.

- B. Proceed with installation only after unsatisfactory conditions have been corrected.

3.2 INSTALLATION

- A. Install electric heating cable at locations indicated and in accordance with NFPA 70.
- B. Install electric heating cable across expansion, construction, and control joints in accordance with manufacturer's written instructions; use cable-protection conduit and slack cable to allow movement without damage to cable.
- C. Install electric heating cables after piping has been tested and before insulation is installed.
- D. Install electric heating cables in accordance with IEEE 515.1.
- E. Install insulation over piping with electric cables in accordance with Section 220719 "Plumbing Piping Insulation."
- F. Install warning tape on piping insulation where piping is equipped with electric heating cables.
- G. Set field-adjustable switches and circuit-breaker trip ranges.
- H. Install temperature-control units in an accessible location and in accordance with manufacturer's written instructions. Locate sensing bulbs to sense outside air temperature in a location where it will not be affected by direct sunlight or other heat sources.
- I. Install control panels and distribution panels where indicated and in accordance with manufacturer's written instructions.
- J. Install and connect outside air and pipe temperature sensors.

3.3 ELECTRICAL CONNECTIONS

- A. Ground equipment in accordance with Section 260526 "Grounding and Bonding for Electrical Systems."
- B. Connect wiring in accordance with Section 260519 "Low-Voltage Electrical Power Conductors and Cables."
- C. Connect temperature-control unit for freeze protection to interrupt power supply to electric heating cable when outside air is above set point.
- D. Connect temperature-control unit for domestic hot-water-temperature maintenance to interrupt power supply to electric heating cable when hot water is above set point.
- E. Connect remote electronic temperature sensors.

3.4 FIELD QUALITY CONTROL

- A. Testing Agency: Engage a qualified testing agency to perform tests and inspections.
- B. Manufacturer's Field Service: Engage a factory-authorized service representative to test and inspect components, assemblies, and equipment installations, including connections.
- C. Perform the following tests and inspections:
 - 1. Perform tests after cable installation but before application of coverings, such as insulation, wall or ceiling construction, or concrete.
 - 2. Test cables for electrical continuity and insulation integrity before energizing.
 - 3. Test cables to verify rating and power input. Energize and measure voltage and current simultaneously.
- D. Repeat tests for continuity, insulation resistance, and input power after applying thermal insulation on pipe-mounted cables.
- E. Cables will be considered defective if they do not pass tests and inspections.
- F. Prepare test and inspection reports.

3.5 PROTECTION

- A. Protect installed heating cables, including nonheating leads, from damage.
- B. Remove and replace damaged heat-tracing cables.

END OF SECTION 220533

SECTION 224000 - PLUMBING FIXTURES

PART 1 - GENERAL

1.1 RELATED DOCUMENTS

- A. Drawings and general provisions of the Contract, including General and Supplementary Conditions and Division 1 Specification Sections, apply to this Section.
- B. Related Sections include the following:
 - 1. Division 23 Section "Common Work Results"
 - 2. Division 22 Plumbing Sections

1.2 SUMMARY

- A. This Section includes Plumbing Fixtures.

1.3 SUBMITTALS

- A. Product Data: Include selected fixture and trim, fittings, accessories, appliances, appurtenances, equipment, and supports and indicate materials and finishes, dimensions, construction details, and flow-control rates for each type of fixture indicated.
- B. Maintenance Data: For plumbing fixtures to include in maintenance manuals specified in Division 1.

1.4 QUALITY ASSURANCE

- A. Source Limitations: Obtain plumbing fixtures, faucets, and other components of each category through one source from a single manufacturer. Exception: If fixtures, faucets, or other components are not available from a single manufacturer, obtain similar products from other manufacturers specified for that category.
- B. Comply with the local building and plumbing codes.
- C. Regulatory Requirements: Comply with requirements in ICC A117.1, "Accessible and Usable Buildings and Facilities"; Public Law 90-480, "Architectural Barriers Act"; and Public Law 101-336, "Americans with Disabilities Act"; about plumbing fixtures for people with disabilities.
- D. Regulatory Requirements: Comply with requirements in Public Law 102-486, "Energy Policy Act," about water flow and consumption rates for plumbing fixtures.
- E. NSF Standard: Comply with NSF 61, "Drinking Water System Components - Health Effects," for fixture materials that will be in contact with potable water.

- F. Coordinate roughing-in and final plumbing fixture locations, and verify that fixtures can be installed to comply with original design and referenced standards.

PART 2 - PRODUCTS

2.1 GENERAL

A. Common Plumbing Fixture Requirements

1. Provide combinations of fixtures and trim, faucets, fittings, and other components that are compatible.
2. Fixtures shall be provided appurtenances such as traps, supplies, faucets, stop valves, and drain fittings – for a complete, finished, code-compliant installation.
3. Coordinate fixture rough in dimensions for conflicts with surrounding structure, prior to submitting.
4. Each fixture and piece of equipment requiring connections to the drainage system shall be equipped with a trap.
5. Fixture supports for off-the-floor fixtures shall be of the chair-carrier type. The carrier shall provide the necessary means of mounting the fixture, with a foot or feet to anchor the assembly to the floor slab. Adjustability shall be provided to locate the fixture at the desired height and in proper relation to the wall. Support plates, in lieu of chair carrier, shall be fastened to the wall structure only where it is not possible to anchor a floor-mounted chair carrier to the floor slab. Waste-fitting assembly, as required to match drainage piping material and arrangement with faceplates, couplings gaskets, and feet; bolts and hardware matching fixture.
6. Provide access panels to concealed valves and components. All components shall have proper access in accordance with manufactures' recommendations.
7. Mounting heights: Refer to Architectural Plans.
8. Water line components shall be lead-free.

2.2 SERVICE SINK

A. Manufacturers:

1. Fiat (Basis of Design)
2. Mustee
3. Just

B. **P-1:** Service Sink: Fiat FL1 Molded Stone Laundry Tub, wall mounted, supported with one mounting bracket of heavy gauge galvanized steel, secured o wall with mechanical fasteners (included with fixture). Furnish with the following:

1. Install check valves at HW and CW connections.
2. One (1) drain, one (1) drain plug, one (1) screw bag and installation instructions
3. 23" x 21 1/2" dimensions
4. White molded plastic polymer side fillers, assembled in the field, connected to the mounting brackets.
5. Includes A1 chrome plated faucet with 4" centerset, 4" (102 mm) blade handles,

8" swing spout, angled hose connection

PART 3 - EXECUTION

3.1 EXAMINATION

- A. Examine roughing-in of water supply and sanitary drainage and vent piping systems to verify actual locations of piping connections before fixture installation. Use manufacturer's roughing-in data if roughing-in data are not indicated.
- B. Examine walls, floors, and cabinets for suitable conditions where fixtures are to be installed.
- C. Proceed with installation only after unsatisfactory conditions have been corrected.

3.2 FIXTURE INSTALLATION - GENERAL

- A. Assemble and support fixtures, trim, fittings, and other components according to manufacturers' written instructions.
- B. Provide fixtures level and plumb according to manufacturers' written instructions and roughing-in drawings.
- C. Provide water-supply piping with stop on each supply to each fixture to be connected to water distribution piping. Attach supplies to supports or substrate within pipe spaces behind fixtures. Provide stops in locations where they can be easily reached for operation.
- D. Provide traps on fixture outlets as required.
 - 1. Provide level and plumb according to roughing-in drawings.
- E. Provide supports and connections to fixtures per manufacturer's instructions.
- F. Provide escutcheons at piping wall ceiling penetrations in exposed, finished locations and within cabinets and millwork. Use deep-pattern escutcheons if required to conceal protruding fittings.
- G. Set floor mounted fixtures in a leveling bed of cement grout as per fixture manufacturer's instructions.
- H. Joint Sealing: Seal joints between fixtures and walls, floors, and counters using sanitary-type, one-part, mildew-resistant, silicone sealant. Match sealant color to water-closet color. Comply with sealant requirements specified in Division 9.
- I. Wall Flange and Escutcheon Installation: Provide wall flanges or escutcheons at piping wall penetrations in exposed, finished locations and within cabinets and millwork. Provide deep-pattern escutcheons if required to conceal protruding fittings.

3.3 SINKS AND LAVATORIES

- A. Provide supports, affixed to building substrate, for wall-mounted lavatories.
- B. Operate and adjust controls. Replace damaged and malfunctioning sinks, fittings, and controls. Adjust water pressure at faucets to produce proper flow.

3.4 CONNECTIONS

- A. Piping installation requirements are specified in other Division 22 Sections. Drawings indicate general arrangement of piping, fittings, and specialties.
- B. Use chrome-plated brass or copper tube, fittings, and valves in locations exposed to view. Plain copper tube, fittings, and valves may be used in concealed locations.
- C. Supply and Waste Connections to Plumbing Fixtures: Connect fixtures with water supplies, stops, risers, traps, and waste piping. Use size fittings required to match fixtures. Connect to plumbing piping.

3.5 FIELD QUALITY CONTROL

- A. Verify that installed fixtures are categories and types specified for locations where installed. Check that fixtures are complete with trim, faucets, fittings, and other specified components. Inspect installed fixtures for damage. Replace damaged fixtures and components.
- B. Test installed fixtures after water systems are pressurized for proper operation. Replace malfunctioning fixtures and components, then retest. Repeat procedure until units operate properly.
- C. Set field-adjustable temperature set points of temperature-actuated water mixing valves. Adjust set point within allowable temperature range.
- D. Operate and adjust fixtures. Replace damaged and malfunctioning fixtures, fittings, and controls.
- E. Adjust water pressure to produce proper flow and stream.
- F. Replace washers and seals of leaking and dripping faucets and stops.

3.6 CLEANING

- A. After completing fixture installation, inspect unit. Remove paint splatters and other spots, dirt, and debris. Repair damaged finish to match original finish.
- B. Clean fixtures and other fittings with manufacturers' recommended cleaning methods and materials. Remove faucet spouts and strainers, remove sediment and debris, and reinstall strainers and spouts. Remove sediment and debris from drains.
- C. Clean fixtures, on completion of installation, according to manufacturer's written instructions.

3.7 PROTECTION

- A. Provide protective covering for installed fixtures and fittings.
- B. Do not allow use of fixtures for temporary facilities unless allowed in Division 1.

END OF SECTION 224000

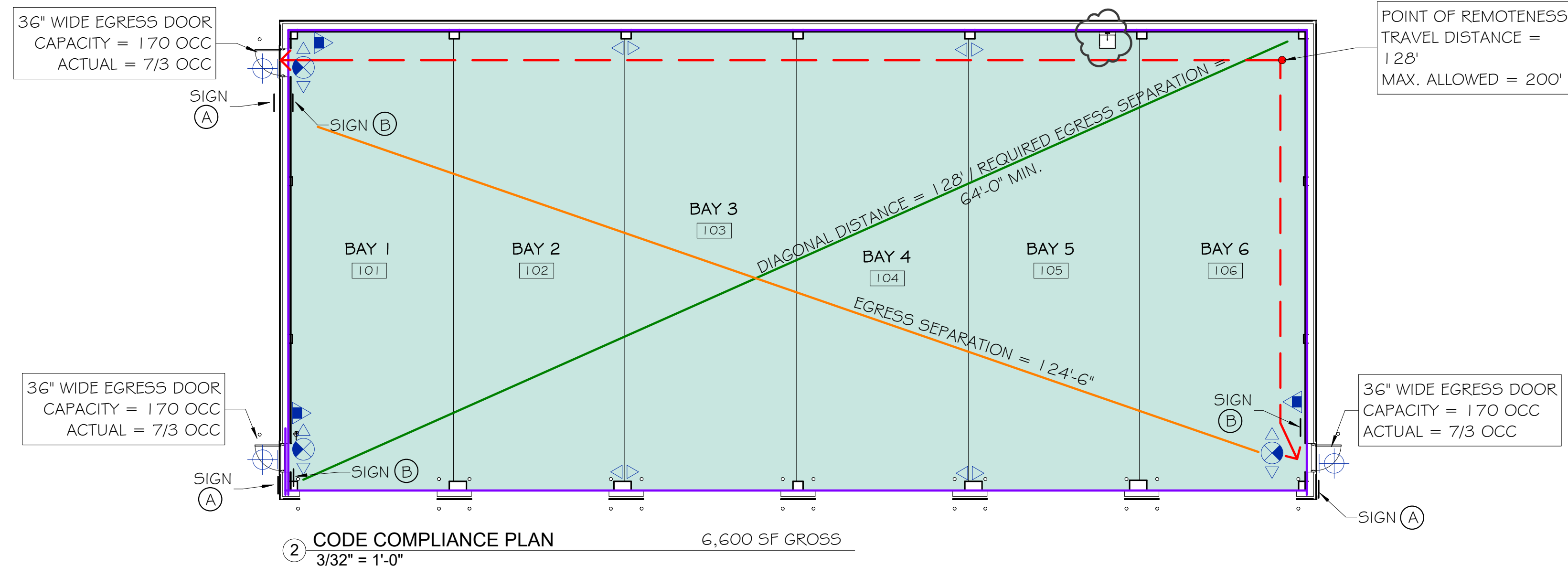

EGRESS SYMBOLS LEGEND	
	DIAGONAL DISTANCE
	EGRESS SEPARATION
	EGRESS PATH

NFPA LEGEND	
	EXIT LIGHT
	ABC FIRE EXTINGUISHER w/ BRACKET
	EMERGENCY LIGHT
	EMERGENCY / EXIT LIGHT
	EXTERIOR EMERGENCY LIGHT

OCCUPANT LOADS	
IBC 2015	14
NFPA 2021	6 (MP)

- NOTES**
- SEE SHEET A-8 FOR ACCESSIBILITY DETAILS & NOTES.
 - SEE SHEET A-8 FOR ADA SIGNAGE.
 - SEE SHEET A-8 ACCESSIBILITY DETAILS AND NOTES FOR MOUNTING HEIGHTS OF LIFE SAFETY DEVICES.

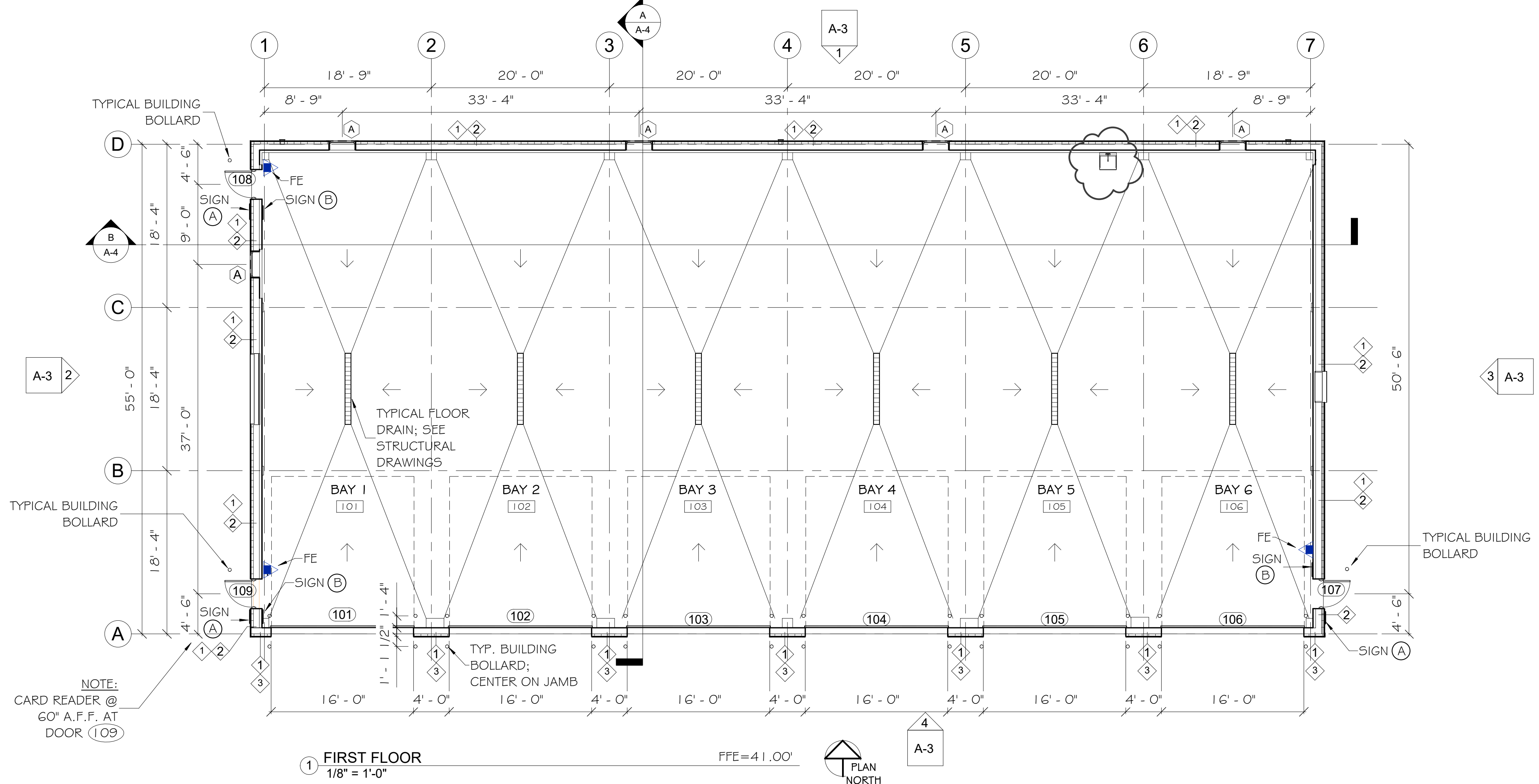

WALL TYPES	
	1/A7
	2/A7
	3/A7

Scale: As indicated

No.	Revision	By	Date
1	ADDENDUM - 1		04/11/24

Designed by:
MICHAEL F. HAYS, RA
ISSUED FOR BID - NOT FOR CONSTRUCTION

By	Date	By	Date
Designed: MFH	03/25/24	Checked: MFH	03/25/24
Drawn: MGK	03/25/24		

GRANT HAYS ASSOCIATES
ARCHITECTURE & INTERIOR DESIGN
P.O. BOX 6179 FALMOUTH MAINE 04105
207.871.5900 www.granthays.com

MAINE TURNPIKE
THE GOLD STAR MEMORIAL HIGHWAY
MTA PROJECT MANAGER: Brian A. Taddeo, P.E.

CONTRACT 2024.09
YORK VEHICLE STORAGE GARAGE
CODE COMPLIANCE & FIRST FLOOR PLANS

CONTRACT: 2024.09
SHEET NUMBER: A-1
12 OF 32

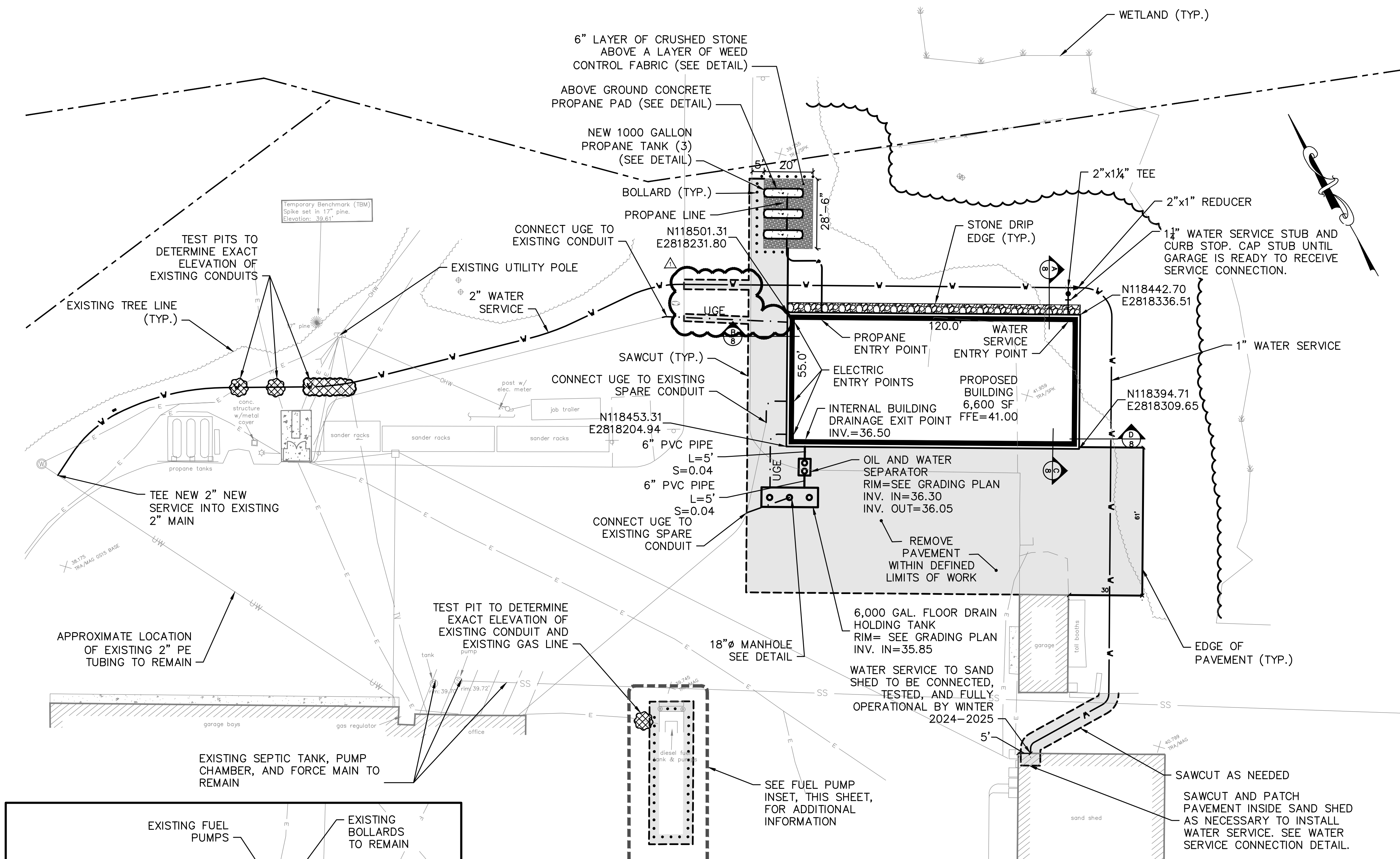

CONCRETE PROPANE TANK PAD - LAYOUT DATA

LOCATION	NORTHING	EASTING
NORTHWEST CORNER	118550.39	2818247.81
NORTHEAST CORNER	118542.58	2818261.77
SOUTHEAST CORNER	118539.52	2818260.06
SOUTHWEST CORNER	118547.34	2818246.10

CONCRETE PROPANE TANK PAD - LAYOUT DATA

LOCATION	NORTHING	EASTING
NORTHWEST CORNER	118542.97	2818243.65
NORTHEAST CORNER	118535.16	2818257.62
SOUTHEAST CORNER	118532.10	2818255.91
SOUTHWEST CORNER	118539.92	2818241.95

CONCRETE PROPANE TANK PAD - LAYOUT DATA

LOCATION	NORTHING	EASTING
NORTHWEST CORNER	118535.56	2818239.50
NORTHEAST CORNER	118527.74	2818253.47
SOUTHEAST CORNER	118524.69	2818251.76
SOUTHWEST CORNER	118532.50	2818237.79

OIL AND WATER SEPARATOR - LAYOUT DATA

LOCATION	NORTHING	EASTING
NORTHWEST CORNER	118446.46	2818207.02
NORTHEAST CORNER	118444.07	2818211.22
SOUTHEAST CORNER	118438.13	2818207.85
SOUTHWEST CORNER	118440.52	2818203.64

6,000 GALLON HOLDING TANK - LAYOUT DATA

LOCATION	NORTHING	EASTING
NORTHWEST CORNER	118443.54	2818187.97
NORTHEAST CORNER	118432.21	2818208.21
SOUTHEAST CORNER	118425.23	2818204.31
SOUTHWEST CORNER	118436.56	2818184.06

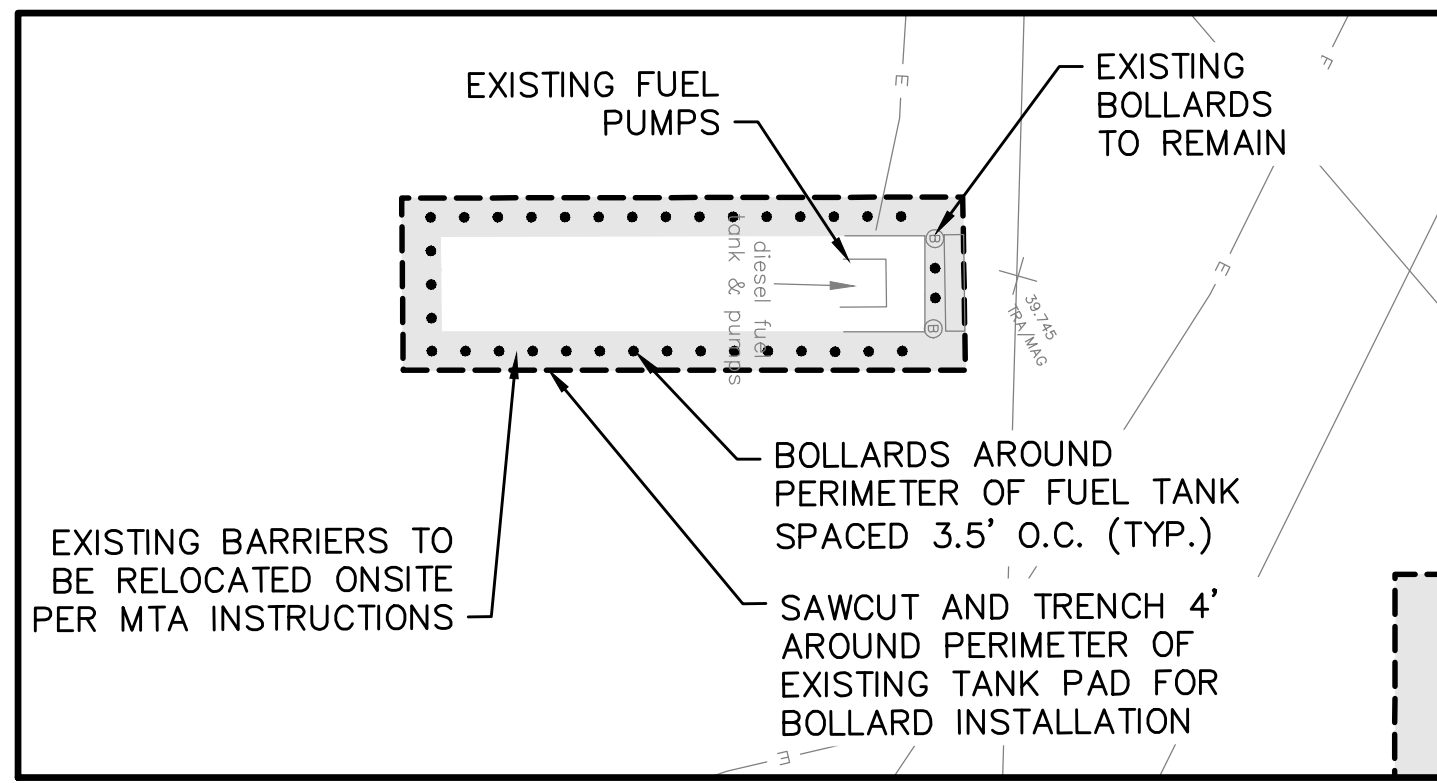

FUEL PUMP BOLLARD INSET
1"=20'

- UTILITY CONSTRUCTION SEQUENCING NOTES:**
- 2" WATER SERVICE, 2"x1 1/4" TEE, 1 1/2" STUB & CURB STOP, 2"x1" REDUCER, AND 1" WATER SERVICE TO SAND SHED ARE TO BE INSTALLED AS PART OF INITIAL PHASE OF WORK. 1" WATER SERVICE TO SAND SHED SHALL BE CONNECTED, TESTED, AND FULLY OPERATIONAL BY WINTER 2024-2025. 1 1/2" WATER SERVICE TO GARAGE SHALL BE EXTENDED FROM STUB IN SUBSEQUENT PHASE OF WORK.

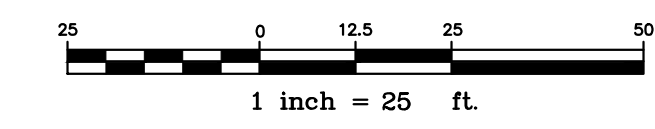

PAVEMENT LEGEND

[Pattern]	HEAVY DUTY BITUMINOUS PAVEMENT
[Pattern]	REINFORCED CONCRETE

Scale: 1"=25'

No.	Revision	By	Date

Designed by:
ALTON M. PALMER, P.E.
MATT RABASCO, P.E.

ISSUED FOR BID - NOT FOR CONSTRUCTION

Designed:	By	Date	Checked:	By	Date
	MYR	03/25/24		AMP	03/25/24

Drawn: CEH 03/25/24

GORRILL PALMER

PROJ. NO.: 3660 CAD FILE: 3660-SP 2024.dwg

MAINE TURNPIKE

THE GOLD STAR MEMORIAL HIGHWAY

MTA PROJECT MANAGER: Brian A. Taddeo, P.E.

CONTRACT 2024.09
YORK VEHICLE STORAGE GARAGE
SITE AND UTILITY PLAN

SHEET NUMBER: C-101

CONTRACT: 2024.09 5 OF 32

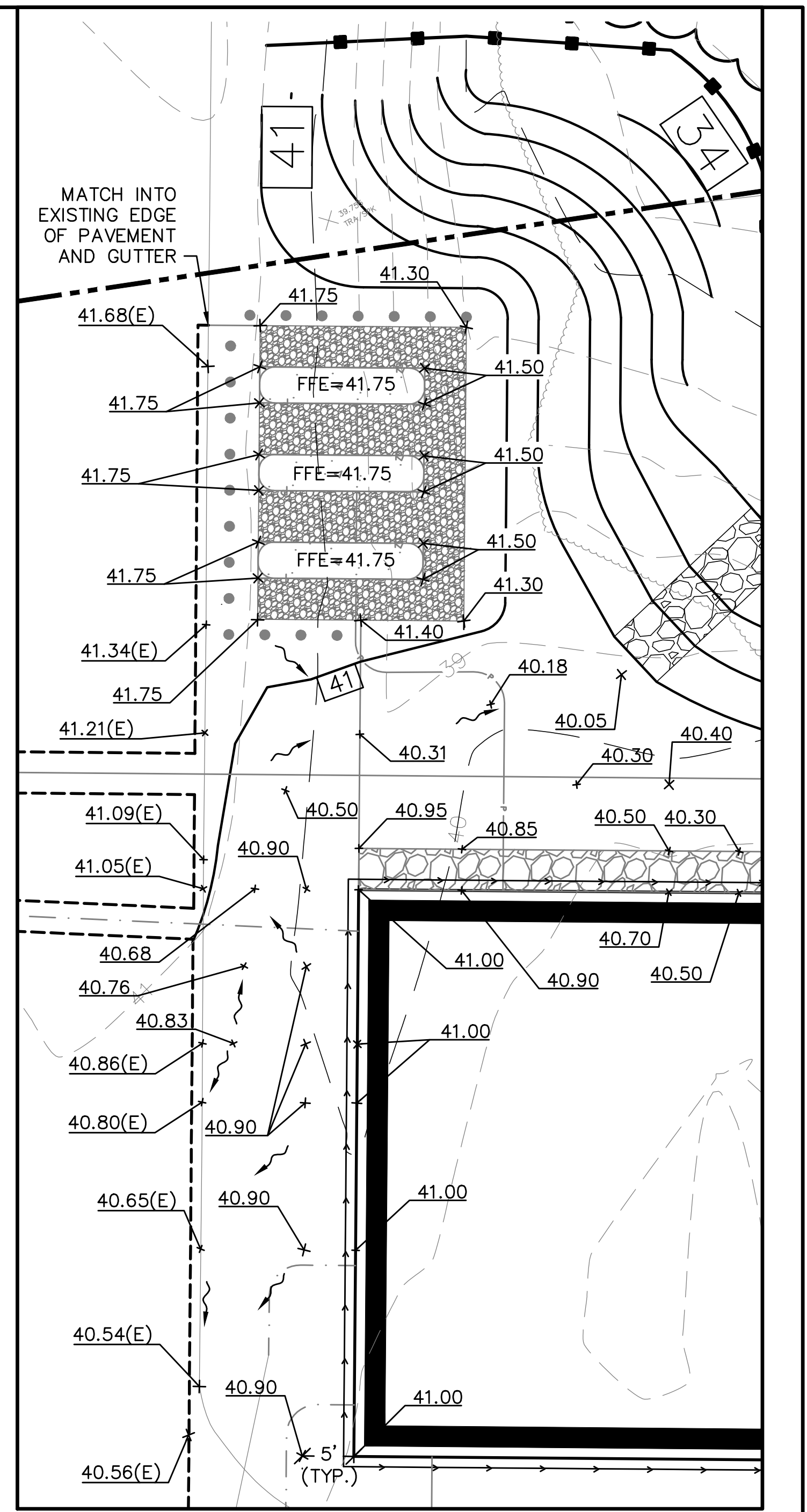
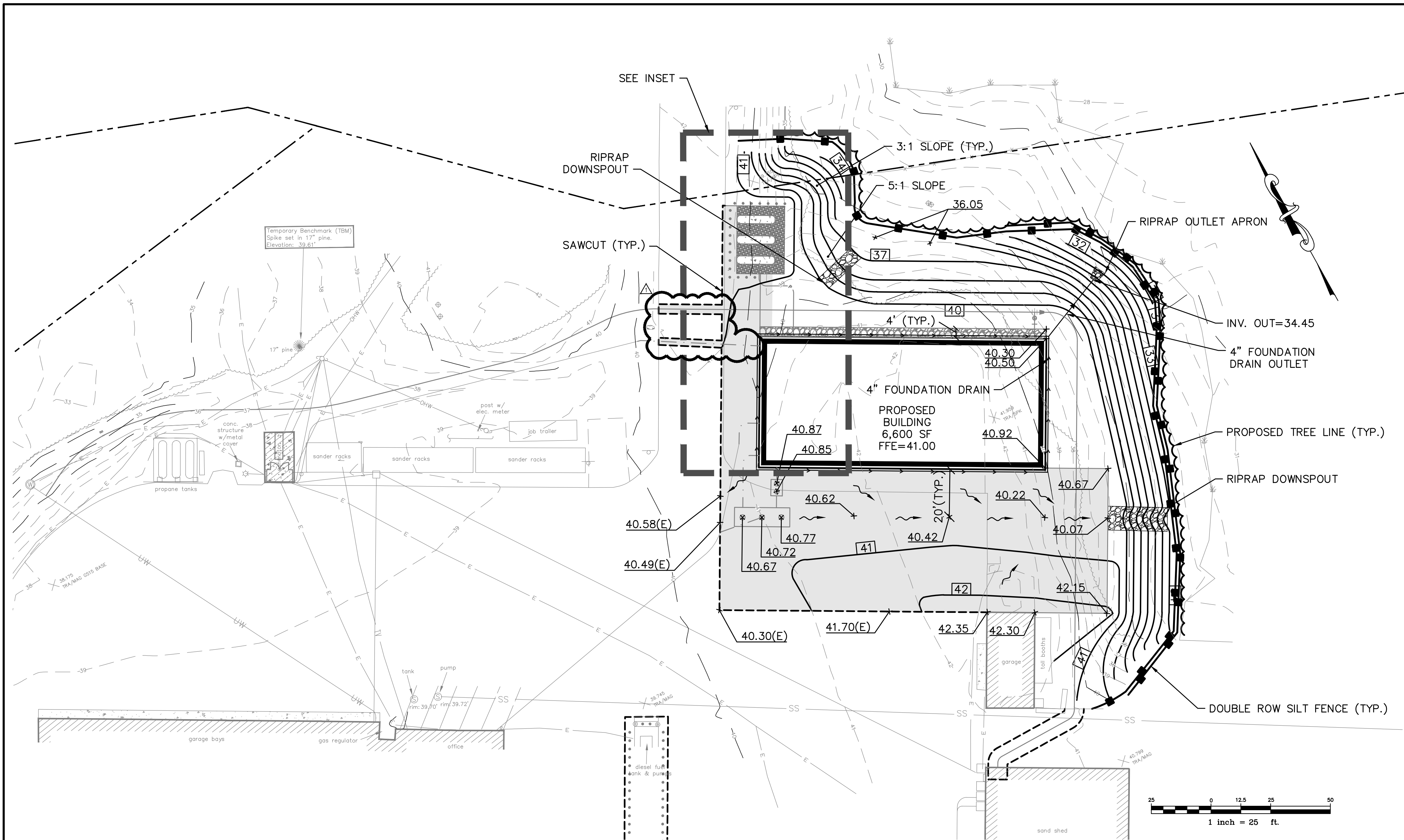

INSET
1"=10'

GENERAL NOTES:

- TOTAL "LIMITS OF DISTURBANCE" IS 0.65 ACRES.
- ADDING 0.27 ACRES OF IMPERVIOUS SURFACE.

GRADING & DRAINAGE NOTES:

- TOPSOIL STRIPPED IN AREAS OF CONSTRUCTION THAT IS SUITABLE FOR REUSE AS LOAM SHALL BE STOCKPILED ON SITE AT A LOCATION TO BE DESIGNATED BY THE OWNER. UNSUITABLE SOIL SHALL BE SEPARATED, REMOVED AND DISPOSED OF AT AN APPROVED DISPOSAL LOCATION OFF SITE.
- THE CONTRACTOR SHALL ANTICIPATE THAT GROUNDWATER WILL BE ENCOUNTERED DURING CONSTRUCTION AND SHALL INCLUDE SUFFICIENT COSTS WITHIN THEIR BID TO PROVIDE DEWATERING AS NECESSARY. NO SEPARATE PAYMENT SHALL BE MADE TO THE CONTRACTOR FOR DEWATERING.
- ALL SITE DISTURBANCE WILL REMAIN WITHIN THE GRADING LIMITS SHOWN ON THE PLANS. NO IMPACTS TO WETLANDS ARE AUTHORIZED.

EROSION CONTROL NOTES:

- LAND DISTURBING ACTIVITIES SHALL BE ACCOMPLISHED IN A MANNER AND SEQUENCE THAT CAUSES THE LEAST PRACTICAL DISTURBANCE OF THE SITE.
- PRIOR TO BEGINNING ANY CLEARING/LAND DISTURBING ACTIVITIES, THE CONTRACTOR SHALL INSTALL THE PERIMETER SILT FENCES AND SEDIMENTATION BARRIERS.
- ALL GROUND AREAS DISTURBED FOR CONSTRUCTION WILL BE GRADED, LOAMED AND SEEDING AS SOON AS POSSIBLE.
- ALL NON-PAVED AREAS DISTURBED DURING CONSTRUCTION SHALL BE LOAMED AND SEEDING, UNLESS OTHERWISE DIRECTED BY THE OWNER. ALL DISTURBED AREAS ARE TO RECEIVE A MINIMUM OF 4" OF TOPSOIL PRIOR TO PERMANENT SEEDING.
- WATER FROM DEWATERING SHALL BE PUMPED THROUGH A DIRT BAG (SEE DETAIL). DIRT BAG OUTLET LOCATION SHALL NOT BE WITHIN 50' OF AN EXISTING WETLAND.
- EROSION CONTROL BLANKET SHALL BE USED ON ALL SLOPES 2:1 OR STEEPER.

Scale:
1"=25'

No.	Revision	By	Date
1	ADDENDUM - 1		4/11/24

Designed by:
ALTON M. PALMER, P.E.
MATT RABASCO, P.E.

ISSUED FOR BID - NOT FOR CONSTRUCTION

Designed:	By	Date	Checked:	By	Date
MYR	CEH	03/25/24	AMP		03/25/24

GORRILL PALMER

MAINE TURNPIKE
THE GOLD STAR MEMORIAL HIGHWAY

CONTRACT 2024.09
YORK VEHICLE STORAGE GARAGE
GRADING, DRAINAGE,
EROSION CONTROL PLAN

SHEET NUMBER: C-102

CONTRACT: 2024.09

6 OF 32

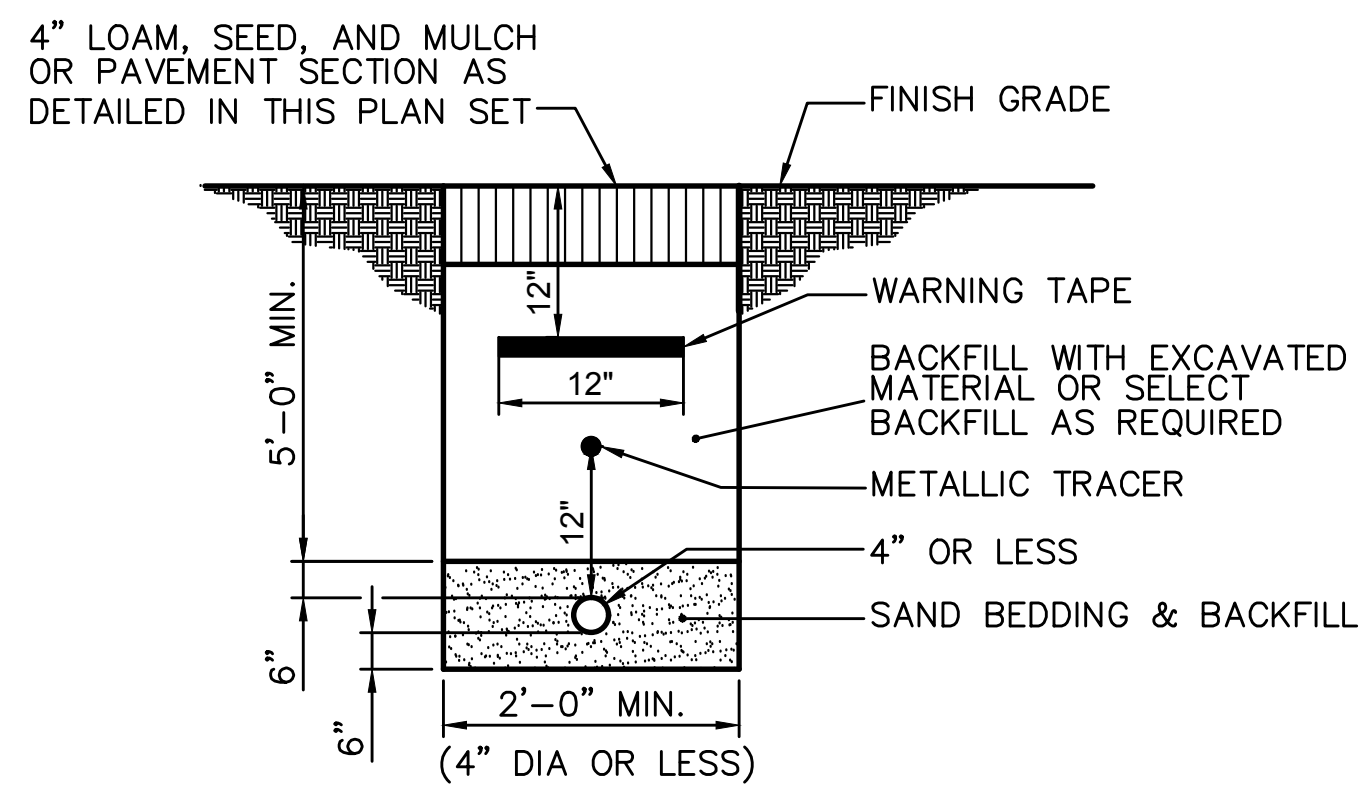
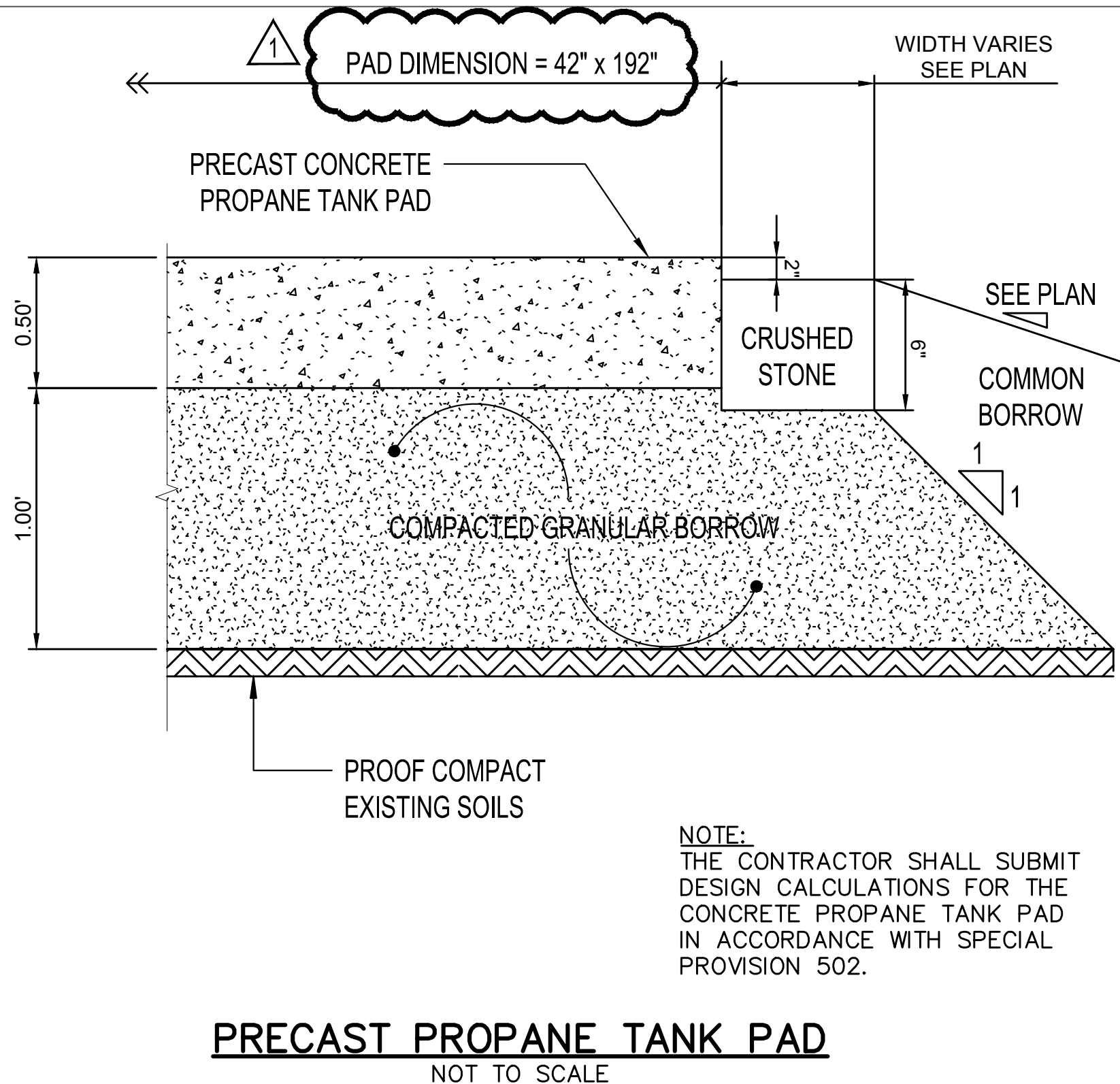

NOTES:
 1. CONTRACTOR TO INSTALL TRACER WIRE OVER PIPE.
 2. WATER LINE INSTALLATION SHALL COMPLY WITH MTA STANDARDS. SITE CONTRACTOR IS RESPONSIBLE FOR EXCAVATION AND BACKFILL OF THE WATER LINE AND PLACEMENT OF THE WARNING TAPES AND TRACER.

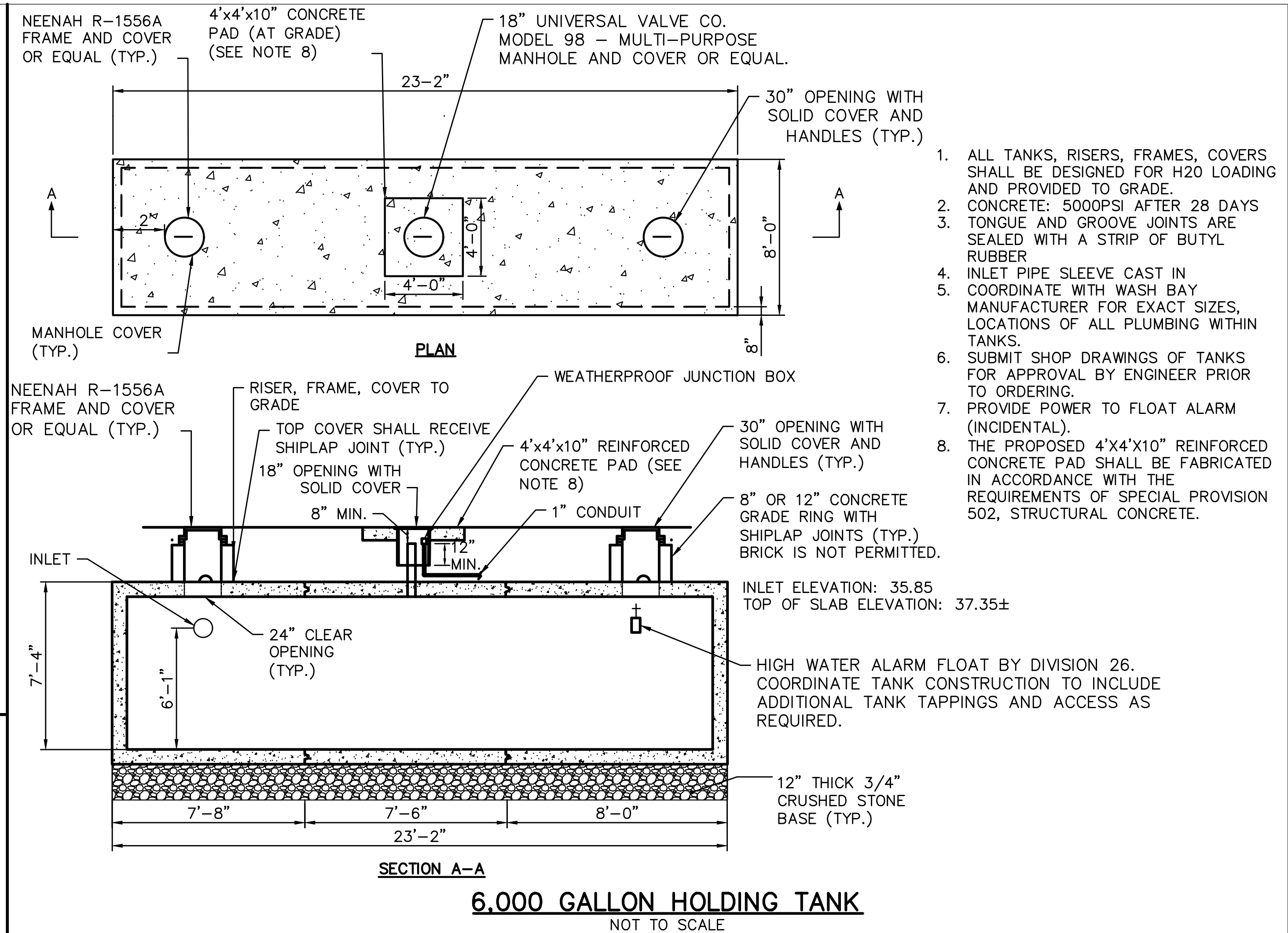

- ALL TANKS, RISERS, FRAMES, COVERS SHALL BE DESIGNED FOR H2O LOADING AND PROVIDED TO GRADE.
- CONCRETE: 5000PSI AFTER 28 DAYS
- TONGUE AND GROOVE JOINTS ARE SEALED WITH A STRIP OF BUTYL RUBBER
- INLET PIPE SLEEVE CAST IN COORDINATE WITH WASH BAY MANUFACTURER FOR EXACT SIZES, LOCATIONS OF ALL PLUMBING WITHIN TANKS.
- SUBMIT SHOP DRAWINGS OF TANKS FOR APPROVAL BY ENGINEER PRIOR TO ORDERING.
- PROVIDE POWER TO FLOAT ALARM (INCIDENTAL).
- THE PROPOSED 4'X4'X10" REINFORCED CONCRETE PAD SHALL BE FABRICATED IN ACCORDANCE WITH THE REQUIREMENTS OF SPECIAL PROVISION 502, STRUCTURAL CONCRETE.

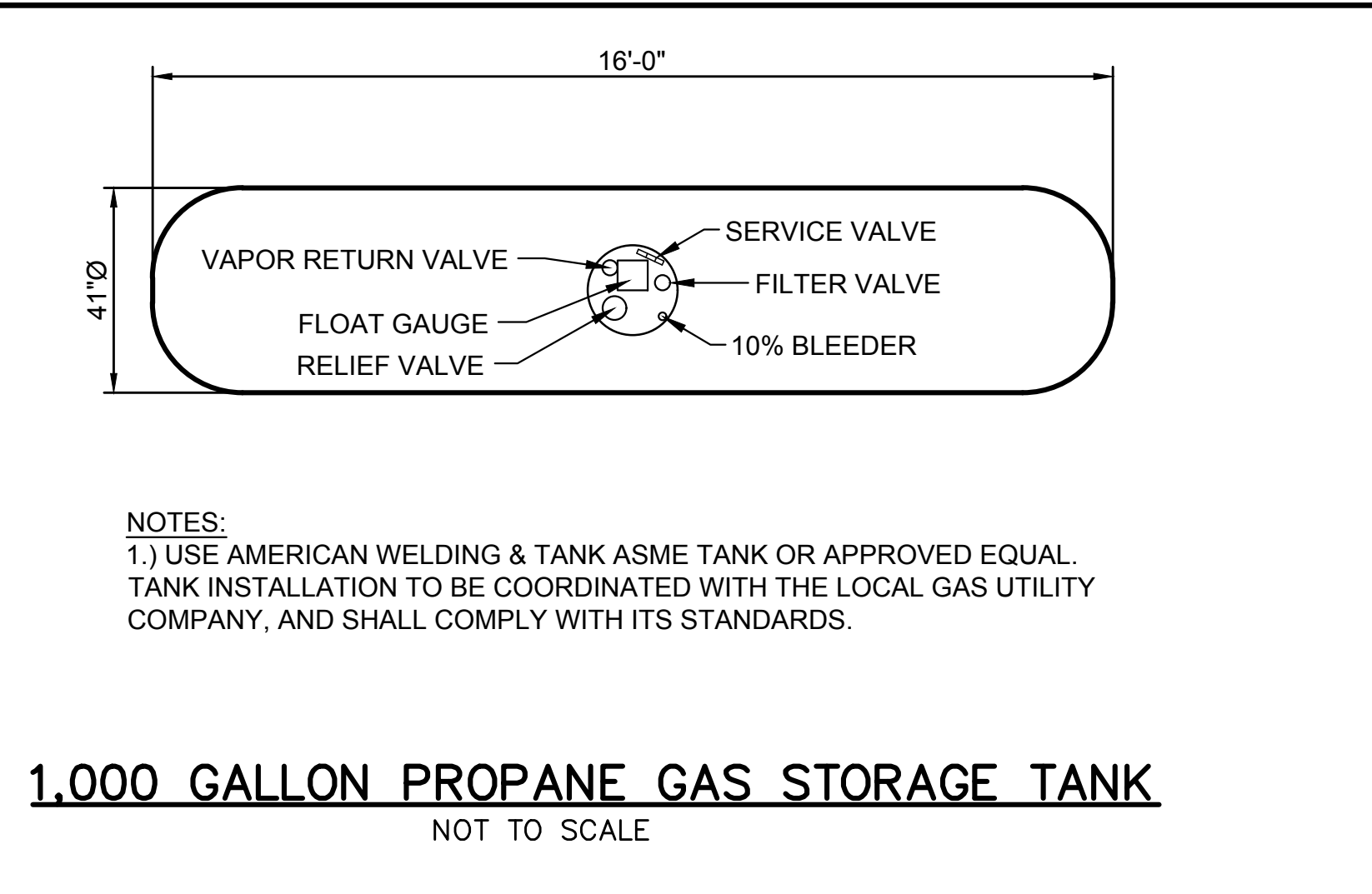

NOTES:
 1. USE AMERICAN WELDING & TANK ASME TANK OR APPROVED EQUAL. TANK INSTALLATION TO BE COORDINATED WITH THE LOCAL GAS UTILITY COMPANY, AND SHALL COMPLY WITH ITS STANDARDS.

- NOTES:
- THE WOOD WASTE COMPOST/BARK MIX SHALL CONFORM TO THE FOLLOWING STANDARDS:
 - MOISTURE CONTENT - 30-60%.
 - pH - 5.0 - 8.0.
 - SCREEN SIZE - 100% LESS THAN 3", MAX. 70% LESS THAN 1".
 - NO LESS THAN 40% ORGANIC MATERIAL (DRY WEIGHT) BY LOSS OF IGNITION.
 - NO STONES LARGER THAN 2" IN DIAMETER.
 - SILTS, CLAYS OR SUGAR SANDS ARE NOT ACCEPTABLE IN THE MIX.
 - THE COMPOST BERM SHALL BE PLACED, UNCOMPACTED, ALONG A RELATIVELY LEVEL CONTOUR.
 - THE WOOD WASTE COMPOST/BARK FILTER BERM MAY BE USED IN LIEU OF SILTATION FENCE, AT THE TOE OF SHALLOW SLOPES, ON FROZEN GROUND, LEDGE OUT CROPS, VERY ROOTED FORESTED AREA OR AT THE EDGE OF GRAVEL PARKING AREAS.
 - BERMS SHALL REMAIN IN PLACE UNTIL UPSTREAM AREA IS COMPLETED OR 70% CATCH OF VEGETATION IS ATTAINED. BERMS SHALL BE REMOVED BY SPREADING SUCH THAT NATIVE EARTH CAN BE SEEN BELOW.

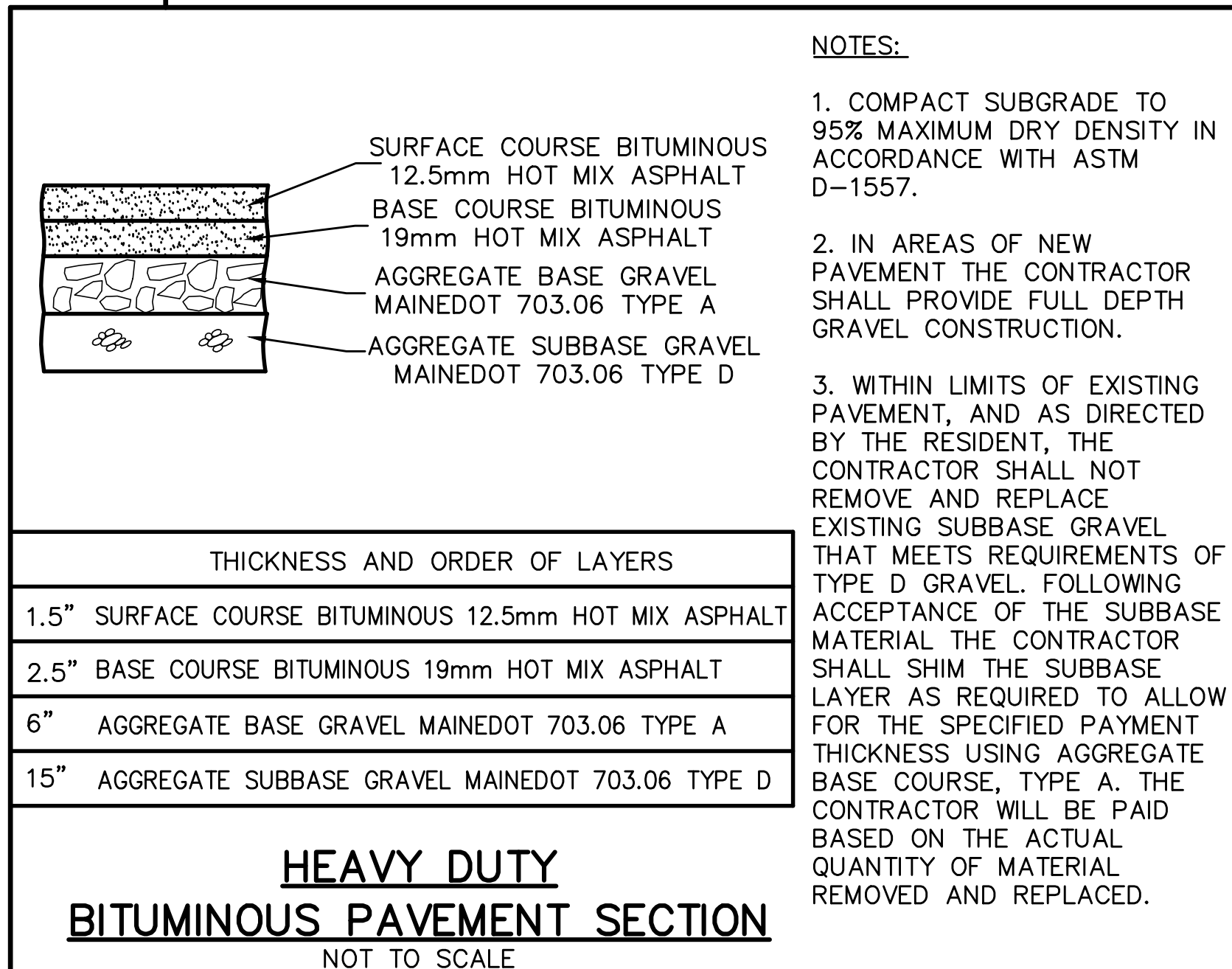

- NOTES:
- COMPACT SUBGRADE TO 95% MAXIMUM DRY DENSITY IN ACCORDANCE WITH ASTM D-1557.
 - IN AREAS OF NEW PAVEMENT THE CONTRACTOR SHALL PROVIDE FULL DEPTH GRAVEL CONSTRUCTION.
 - WITHIN LIMITS OF EXISTING PAVEMENT, AND AS DIRECTED BY THE RESIDENT, THE CONTRACTOR SHALL NOT REMOVE AND REPLACE EXISTING SUBBASE GRAVEL THAT MEETS REQUIREMENTS OF TYPE D GRAVEL. FOLLOWING ACCEPTANCE OF THE SUBBASE MATERIAL THE CONTRACTOR SHALL SHIM THE SUBBASE LAYER AS REQUIRED TO ALLOW FOR THE SPECIFIED PAYMENT THICKNESS USING AGGREGATE BASE COURSE, TYPE A. THE CONTRACTOR WILL BE PAID BASED ON THE ACTUAL QUANTITY OF MATERIAL REMOVED AND REPLACED.

THICKNESS AND ORDER OF LAYERS
1.5" SURFACE COURSE BITUMINOUS 12.5mm HOT MIX ASPHALT
2.5" BASE COURSE BITUMINOUS 19mm HOT MIX ASPHALT
6" AGGREGATE BASE GRAVEL MAINEDOT 703.06 TYPE A
15" AGGREGATE SUBBASE GRAVEL MAINEDOT 703.06 TYPE D

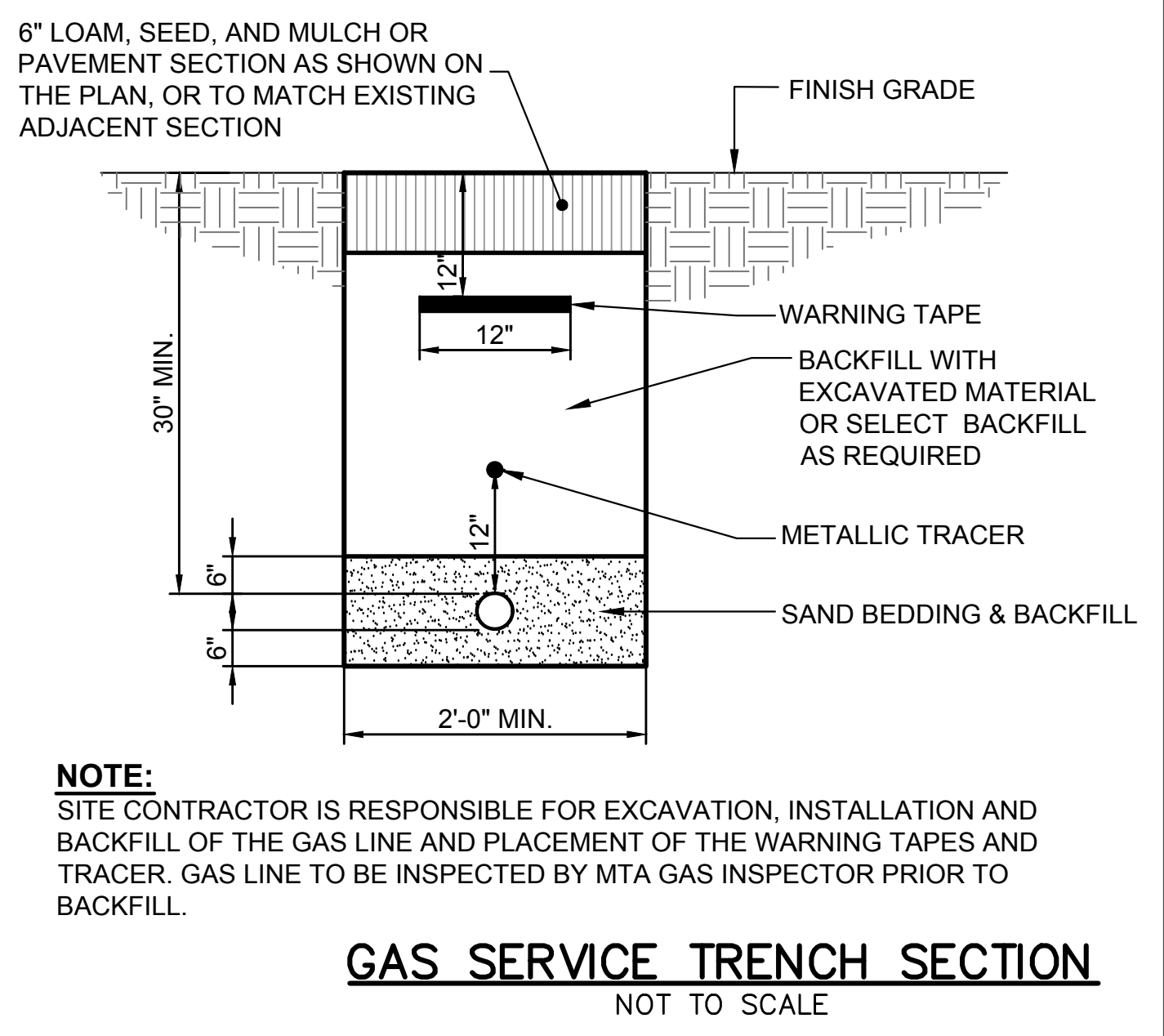

NOTE:
 SITE CONTRACTOR IS RESPONSIBLE FOR EXCAVATION, INSTALLATION AND BACKFILL OF THE GAS LINE AND PLACEMENT OF THE WARNING TAPES AND TRACER. GAS LINE TO BE INSPECTED BY MTA GAS INSPECTOR PRIOR TO BACKFILL.

Scale: N/A

No.	Revision	By	Date
1	ADDENDUM - 1		4/11/24

Designed by:
 ALTON M. PALMER, P.E.
 MATT RABASCO, P.E.

ISSUED FOR BID - NOT FOR CONSTRUCTION

Designed:	By	Date	Checked:	By	Date
MYR	CEH	03/25/24	AMP		03/25/24

PROJ. NO.: 3660 CAD FILE: 3660-DETAILS 2024.dwg

GORRILL PALMER

MAINE TURNPIKE

THE GOLD STAR MEMORIAL HIGHWAY

MTA PROJECT MANAGER: **Brian A. Taddeo, P.E.**

CONTRACT 2024.09
 YORK VEHICLE STORAGE GARAGE
 DETAILS - 1

SHEET NUMBER: C-401

CONTRACT: 2024.09 7 OF 32

PLUMBING FIXTURE SCHEDULE						
TAG	DESCRIPTION	BRANCH SIZES				NOTES
		CW	HW	VENT	WASTE	
P-1	SERVICE SINK	1/2"	1/2"	1-1/2"	2"	WITH MANUAL FAUCET
NOTES:						

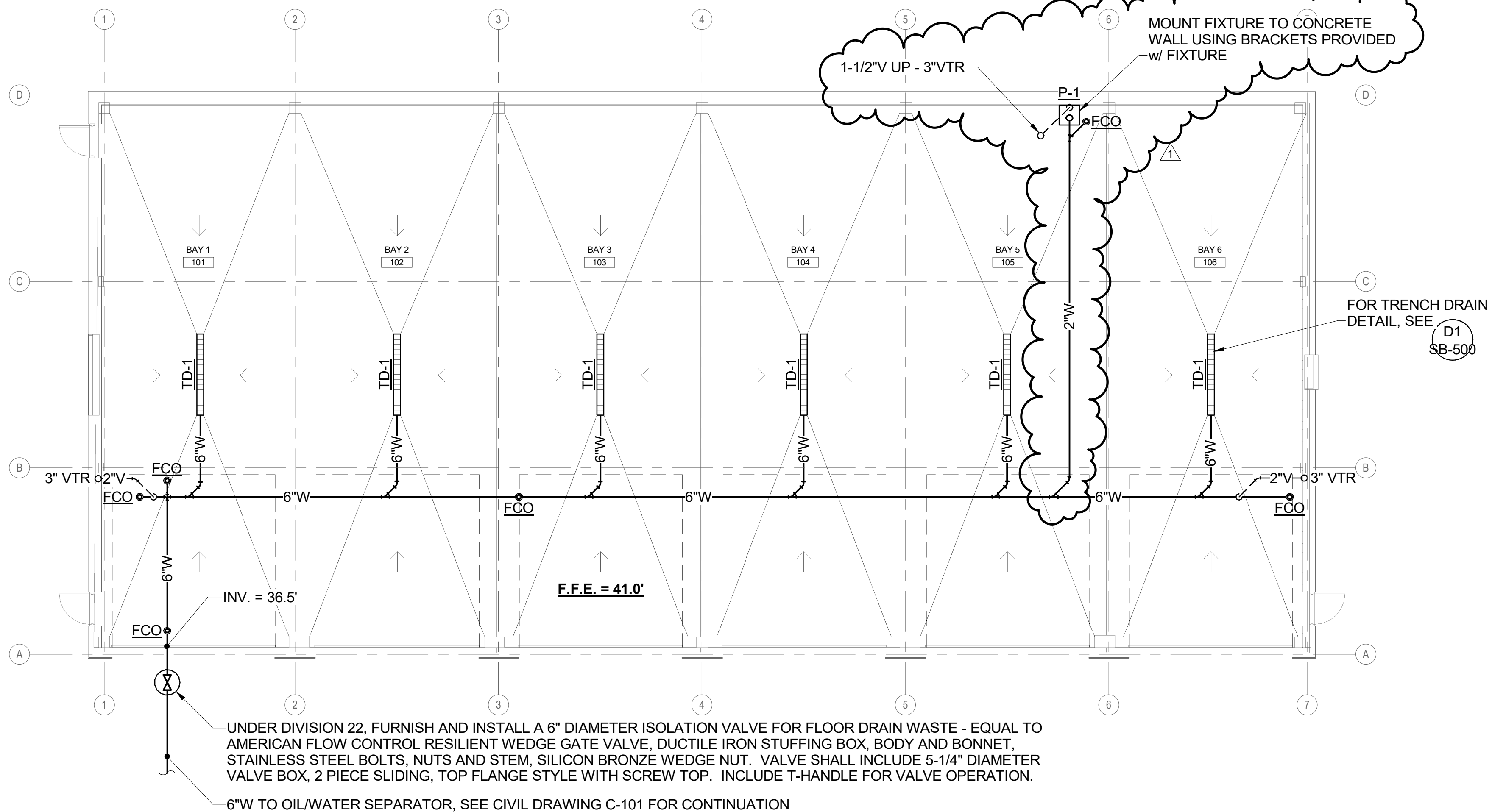

A1 SANITARY PIPING PLAN

1/8" = 1'-0"

No.	Revision	By	Date
1	ADDENDUM - 1	AEI	04/11/24

Designed by: *Anthony Davis*

ANTHONY DAVIS, P.E.

ISSUED FOR BID - NOT FOR CONSTRUCTION

By	Date	By	Date
ASD	03/25/24	ASD	03/25/24
REW	03/25/24		

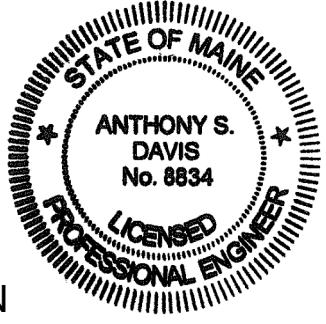

Allied Engineering
 Structural Mechanical Electrical Plumbing
 160 Veranda Street
 Portland, Maine 04103
 P: 207.221.2260
 F: 207.221.2266
 Web: www.allied-eng.com



**THE GOLD STAR
 MEMORIAL HIGHWAY**

CONTRACT 2024.09
 YORK VEHICLE STORAGE GARAGE
 SANITARY PIPING PLAN

EXPANSION TANK SCHEDULE	
SYSTEM	DOMESTIC HOT WATER
PIPE SIZE	3/4"
BLADDER-TYPE EXPANSION TANK	
MFR-MODEL	AMTROL ST-5
TANK DIAMETER	8
TANK HEIGHT	13
ACCEPTANCE VOLUME	2
WEIGHT LBS	5

ELECTRIC WATER HEATER SCHEDULE											
TAG	MANUFACTURER	MODEL	VOLTS	PHASE	HEAT INPUT...	GPH RECOVERY	TEMP RISE...	WATER STORAG...	HEIGHT (INCHES)	DIAMETER (INCHES)	APPROX WEIGHT...
WH-1	AO SMITH	ENS-40	240	1	4.5	21	90	40	49 3/4	20 1/2	445

Note: Water Heater suspended in wall pan shelf equal to Holdrite #60-SWHP-W

AIR COMPRESSOR SCHEDULE														
TAG	MANUFACTURER	MODEL	TYPE	MAXIMUM FLOW EA. PUMP (acfm)	MAXIMUM PUMP PRESS. (psig)	RECEIVER			ELECTRICAL			PHYSICAL		NOTES
						SIZE (gal.)	RECEIVER TYPE	DIA. (in.)	MOTOR QUAN.	MOTOR SIZE (hp)	MOTOR SPEED (rpm)	VOLT/PH	LENGTH/ WIDTH/ HEIGHT (in.)	
AC-1	INGERSOLL RAND	2475N7.5	2-STAGE RECI	24	175	80	VERTICAL	38	1	7.5	---	230/1	38/26/70	

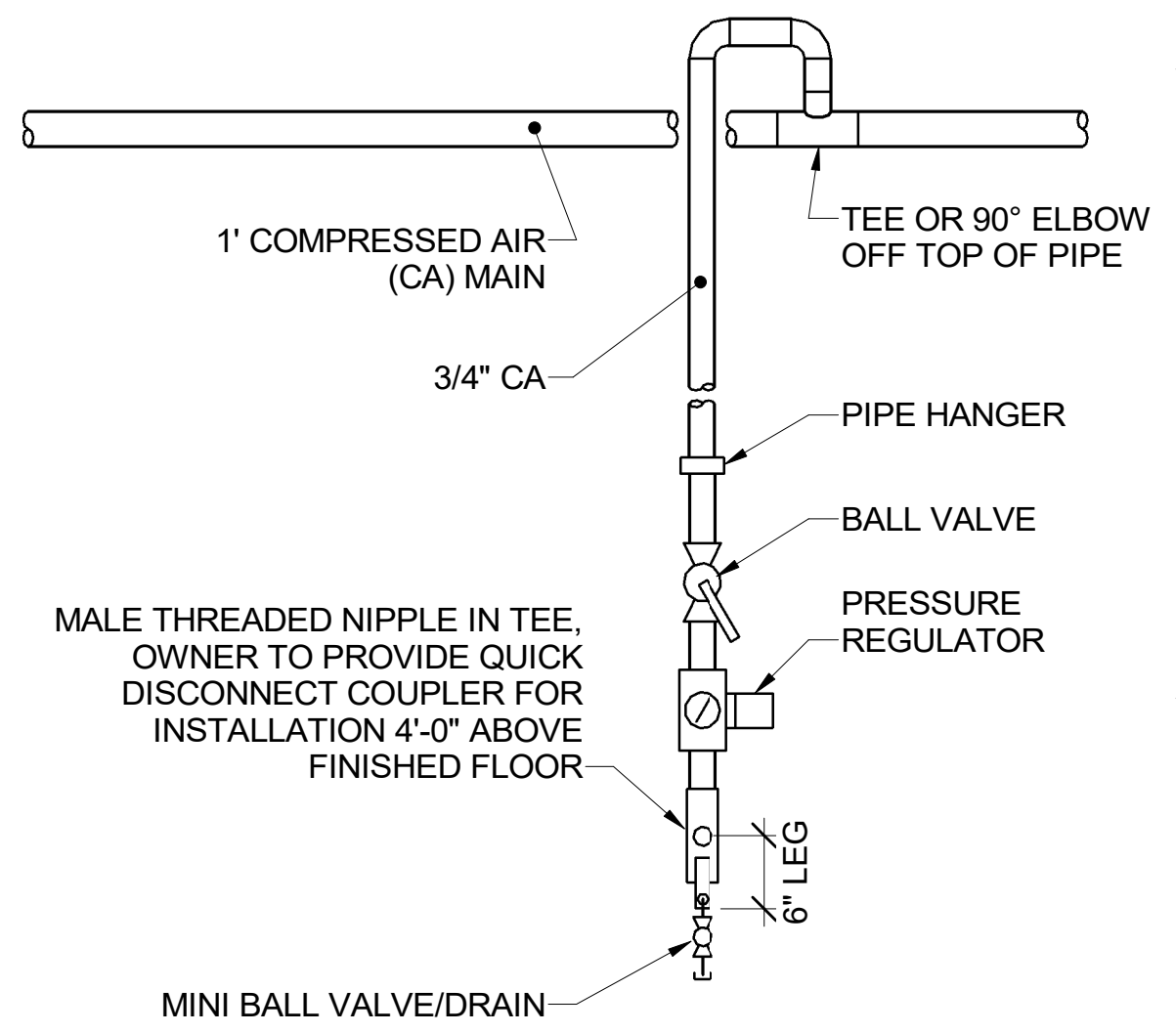

D1	PLUMBING SCHEDULES	D6	REVISED WATER ENTRANCE PIPING	D8	DETAIL - COMP. AIR TOOL CONN. PIPING
NONE		NONE		NOT TO SCALE	

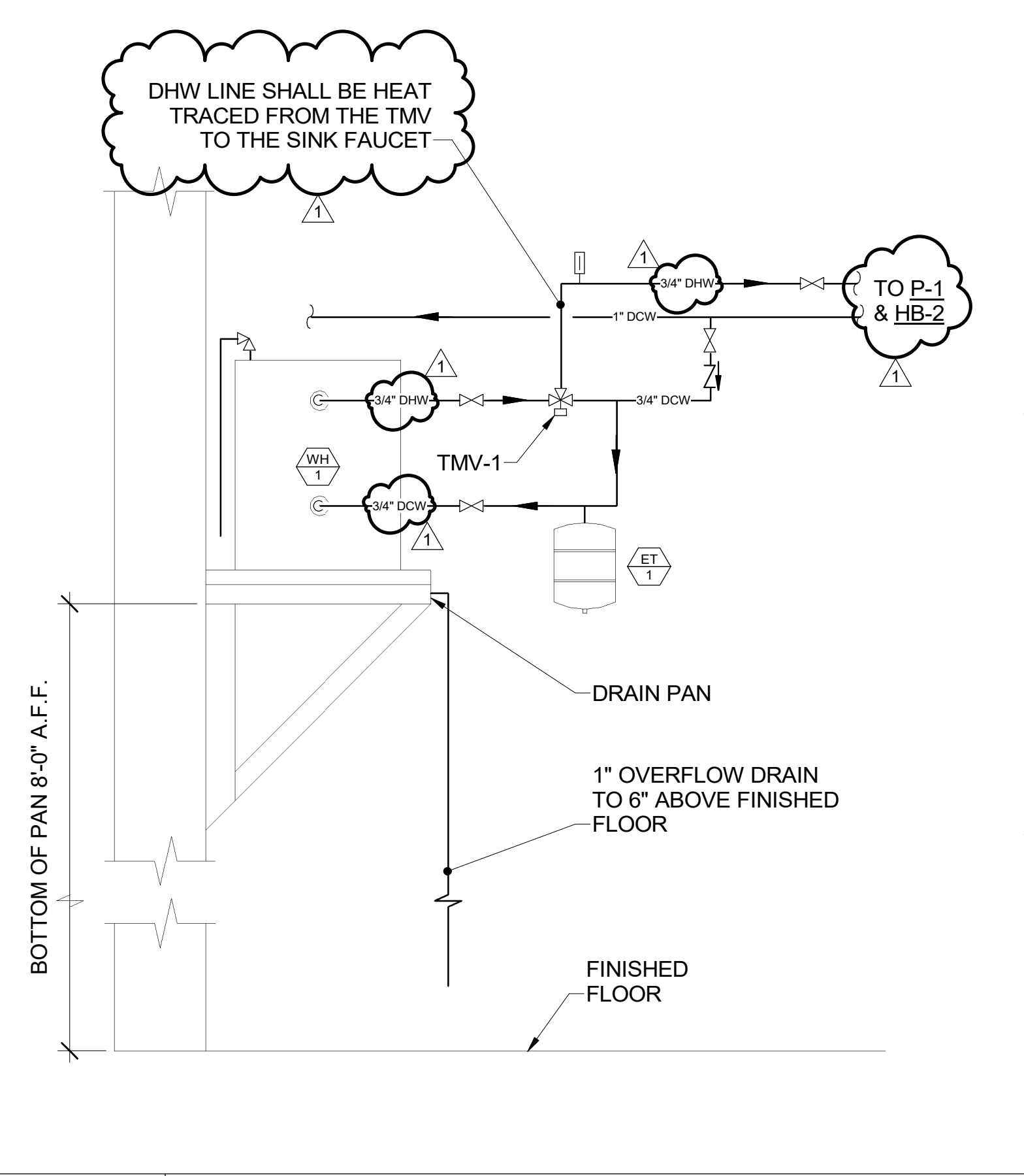
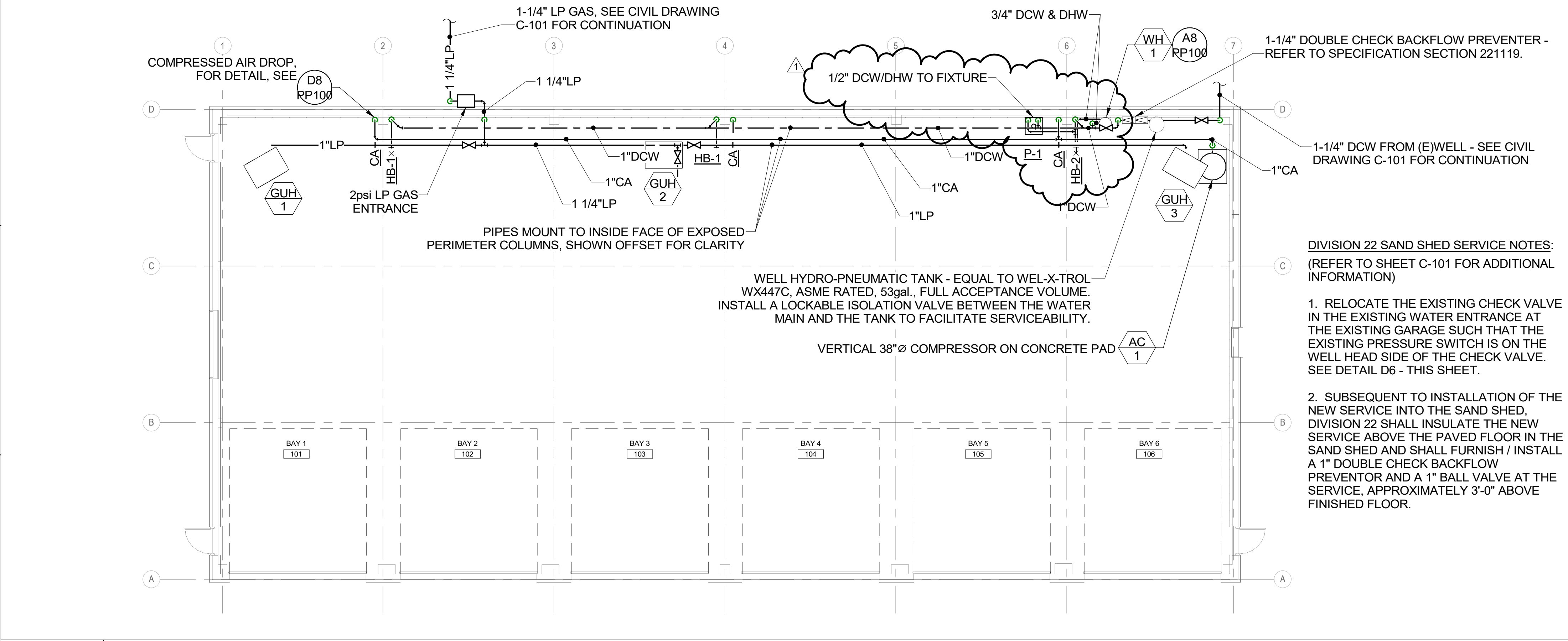

A1	DOMESTIC PIPING PLAN	A8	DETAIL - DOMESTIC WATER HEATER PIPING SCHEMATIC - WH-1
1/8" = 1'-0"		NOT TO SCALE	

Scale: As indicated

No.	Revision	By	Date
1	ADDENDUM - 1	AEI	04/11/24

Designed by: *Anthony Davis*

ANTHONY DAVIS, P.E.

ISSUED FOR BID - NOT FOR CONSTRUCTION

By	Date	By	Date
ASD	03/25/24	ASD	03/25/24
REW	03/25/24		

Allied Engineering
Structural Mechanical Electrical Plumbing

160 Veranda Street
Portland, Maine 04103
P: 207.221.2260
F: 207.221.2266
Web: www.allied-eng.com

MAINE TURNPIKE

THE GOLD STAR MEMORIAL HIGHWAY

MTA PROJECT MANAGER: Brian A. Taddeo, P.E.

CONTRACT 2024.09
YORK VEHICLE STORAGE GARAGE
DOMESTIC PIPING PLAN

SHEET NUMBER: PP-100

CONTRACT: 2024.09

26 OF 32

Lighting and Appliance Panelboard:

MDP

Location: BAY 1 101
 Supply From: DP
 Mounting: Surface
 Volts: 120/240 Single
 Phases: 1
 Wires: 3
 A.I.C. Rating: 22kAIC
 Mains Type: MCB
 Bus Rating: 225 A
 MCB Rating: 200 A

CKT	Circuit Description	Trip Amps	Poles	A (kVA)		B (kVA)		Trip Amps	Circuit Description	CKT	
1	DOOR OPERATOR BAY 1	20	1	1.4	0.4			15	DESTRAT FANS	2	
3	DOOR OPERATOR BAY 2	20	1			1.4	0.2	20	HEAT TRACE FOR SINK	4	
5	DOOR OPERATOR BAY 3	20	1	1.4	0.5			20	HVAC CONTROL POWER	6	
7	DOOR OPERATOR BAY 4	20	1			1.4	0.2	20	Receptacles	8	
9	DOOR OPERATOR BAY 5	20	1	1.4	1.1			20	Receptacles	10	
11	DOOR OPERATOR BAY 6	20	1			1.4	0.7	20	Receptacles	12	
13	Receptacles	20	1	0.7	0.7			20	Receptacles	14	
15	GUH-1	20	1			0.7	0.9	20	Receptacles	16	
17	GUH-3	20	1	0.7	0.7			20	Receptacles	18	
19	LIGHTING, SWITCH a	20	1			0.7	0.7	20	GUH-2	20	
21	LIGHTING, SWITCHES b,c	20	1	1	0.7			20	CORD REELS BAYS 1-2	22	
23	EXTERIOR BUILDING LIGHTING	20	1			0.7	0.7	20	CORD REELS BAYS 3-4	24	
25	LP GAS CO DETECTOR	20	1	1	0.7			20	CORD REELS BAYS 5-6	26	
27	Heating - WH-1	30	2			2.3	0	20	Spare	28	
29	Spare	20	1	2.3	0			20	Spare	30	
31	Spare	20	1	0	0	0	0	20	Spare	32	
33	Spare	20	1	0	0			20	Spare	34	
35	Spare	20	1	0	0	0	1.4	25	HVAC - EF-1	36	
37	Spare	20	1	0	1.4			25		38	
39	Spare	20	1			0	4.8	80	HVAC - AC-1	40	
41	Spare	20	1	0	4.8					42	
43	Spare	20	1			0	0	20	Spare	44	
45	Spare	20	1	0	0			20	Spare	46	
47	Spare	20	1			0	0	20	Spare	48	
49	Spare	20	1	0	0			20	Spare	50	
51	Spare	20	1			0	0	20	Spare	52	
53	Spare	20	1	0	0			20	Spare	54	
55	Spare	20	1			0	0	20	Spare	56	
Total Load:				20.1 kVA	17.7 kVA						
Total Amp:				168 A	147 A						

Notes:

SPECIAL RECEPTACLE SCHEDULE

TAG	NEMA	DESCRIPTION (SINGLE DEVICE)	OCPD	BRANCH CIRCUIT
A	5-15R	15A-125V,2P,3W	15A-1P	2#12 & 1#12GND - 3/4" C
B	5-20R	20A-125V,2P,3W	20A-1P	2#12 & 1#12GND - 3/4" C
C	5-30R	30A-125V,2P,3W	30A-1P	2#10 & 1#10GND - 3/4" C
D	5-50R	50A-125V,2P,3W	50A-1P	2#6 & 1#10GND - 3/4" C
E	6-20R	20A-250V,2P,3W	20A-2P	2#12 & 1#12GND - 3/4" C
F	L6-20R	20A-250V,2P,3W	20A-2P	2#12 & 1#12GND - 3/4" C
G	6-30R	30A-250V,2P,3W	30A-2P	2#10 & 1#10GND - 3/4" C
H	L6-50R	50A-250V,2P,3W-LOCKING	50A-2P	2#6 & 1#10GND - 3/4" C
I	14-20R	20A-125/250V,3P,4W	20A-2P	3#12 & 1#12GND - 3/4" C
J	14-30R	30A-125/250V,3P,4W	30A-2P	2#10 & 1#10GND - 3/4" C
K	14-50R	50A-125/250V,3P,4W	50A-2P	3#6 & 1#10GND - 1" C
L	14-60R	60A-125/250V,3P,4W	60A-2P	3#6 & 1#10GND - 1" C
M	L15-20R	20A-250V,3PH,3P,4W	20A-3P	3#12 & 1#12GND - 3/4" C
N	15-30R	30A-250V,3PH,3P,4W	30A-3P	3#10 & 1#10GND - 3/4" C
P	15-50R	50A-250V,3PH,3P,4W	50A-3P	3#6 & 1#10GND - 1" C
Q	15-60R	60A-250V,3PH,3P,4W	60A-3P	3#6 & 1#10GND - 1" C
R	L5-20R	20A-125V,2P,3W, TWIST LOCK	20A-1P	2#12 & 1#12GND - 3/4" C
S	L5-30R	30A-125V,2P,3W, TWIST LOCK	30A-1P	2#10 & 1#10GND - 3/4" C
T	L6-15R	15A-250V,2P,3W, TWIST LOCK	15A-2P	2#12 & 1#12GND - 3/4" C
U	L6-20R	20A-250V,2P,3W, TWIST LOCK	20A-2P	2#12 & 1#12GND - 3/4" C
V	L6-30R	30A-250V,2P,3W, TWIST LOCK	30A-2P	2#10 & 1#10GND - 3/4" C
W	L14-20R	20A-125/250V,3P,4W,TWIST LOCK	20A-2P	3#12 & 1#12GND - 3/4" C
X	L14-30R	30A-125/250V,3P,4W,TWIST LOCK	30A-2P	3#10 & 1#10GND - 3/4" C
Y	L16-20R	20A-480V, 3P,4W, TWIST LOCK	20A-3P	3#12 & 1#12GND - 3/4" C
Z	L11-20R	20A-250V, 3P,4W, TWIST LOCK	20A-3P	3#12 & 1#10GND - 3/4" C

BRANCH CIRCUITS SCHEDULE

CIRCUIT BREAKER	CONDUCTOR
120 OR 277 VOLT, 1 PH., 2W CIRCUITS	
15A-1P, 20A-1P	2#12 & 1#12 GND - 3/4" C.
30A-1P	2#10 & 1#10 GND - 3/4" C.
40A-1P	2#8 & 1#10 GND - 3/4" C.
50A-1P	2#6 & 1#10 GND - 3/4" C.
60A-1P	2#6 & 1#10 GND - 3/4" C.
208 OR 480 VOLT, 1PH., 2W CIRCUITS	
15A-2P, 20A-2P	2#12 & 1#12 GND - 3/4" C.
30A-2P	2#10 & 1#10 GND - 3/4" C.
40A-2P	2#8 & 1#10 GND - 3/4" C.
50A-2P	2#6 & 1#10 GND - 3/4" C.
60A-2P	2#6 & 1#10 GND - 3/4" C.
208 OR 480 VOLT, 3PH., 3W CIRCUITS	
15A-3P, 20A-3P	3#12 & 1#12GND - 3/4" C.
30A-3P	3#10 & 1#10 GND - 3/4" C.
40A-3P	3#8 & 1#10 GND - 3/4" C.
50A-3P	3#6 & 1#10 GND - 3/4" C.
60A-3P	3#6 & 1#10 GND - 3/4" C.

BRANCH CIRCUIT SCHEDULE NOTES:

- TYPE MC CABLE SHALL INCLUDE FULL SIZE INSULATED GROUND CONDUCTOR. SIZES AS INDICATED IN SCHEDULE
- WIRING BASED ON MAXIMUM FEEDER LENGTH OF 150 FEET FOR 120 VOLT CIRCUITS AND 300 FEET FOR 277...
- UPGRADE WIRE AND CONDUIT SIZE AS REQUIRED TO ADDRESS VOLTAGE DROP

VOLTAGE DROP CHART

MAXIMUM LOAD (VA)	MAXIMUM LENGTH PER CONDUCTOR...		
	#12	#10	#8
120 VOLT CIRCUITS			
800	155	245	390
1000	125	195	310
1200	105	165	260
1400	90	140	220
1600	80	125	195
1800	70	110	175
277 VOLT CIRCUITS			
2000	330	525	830
2500	265	420	665
3000	220	350	555
3500	190	300	475
4000	165	260	415

Grounding at metal building steel column per special provision 260526.3.5G

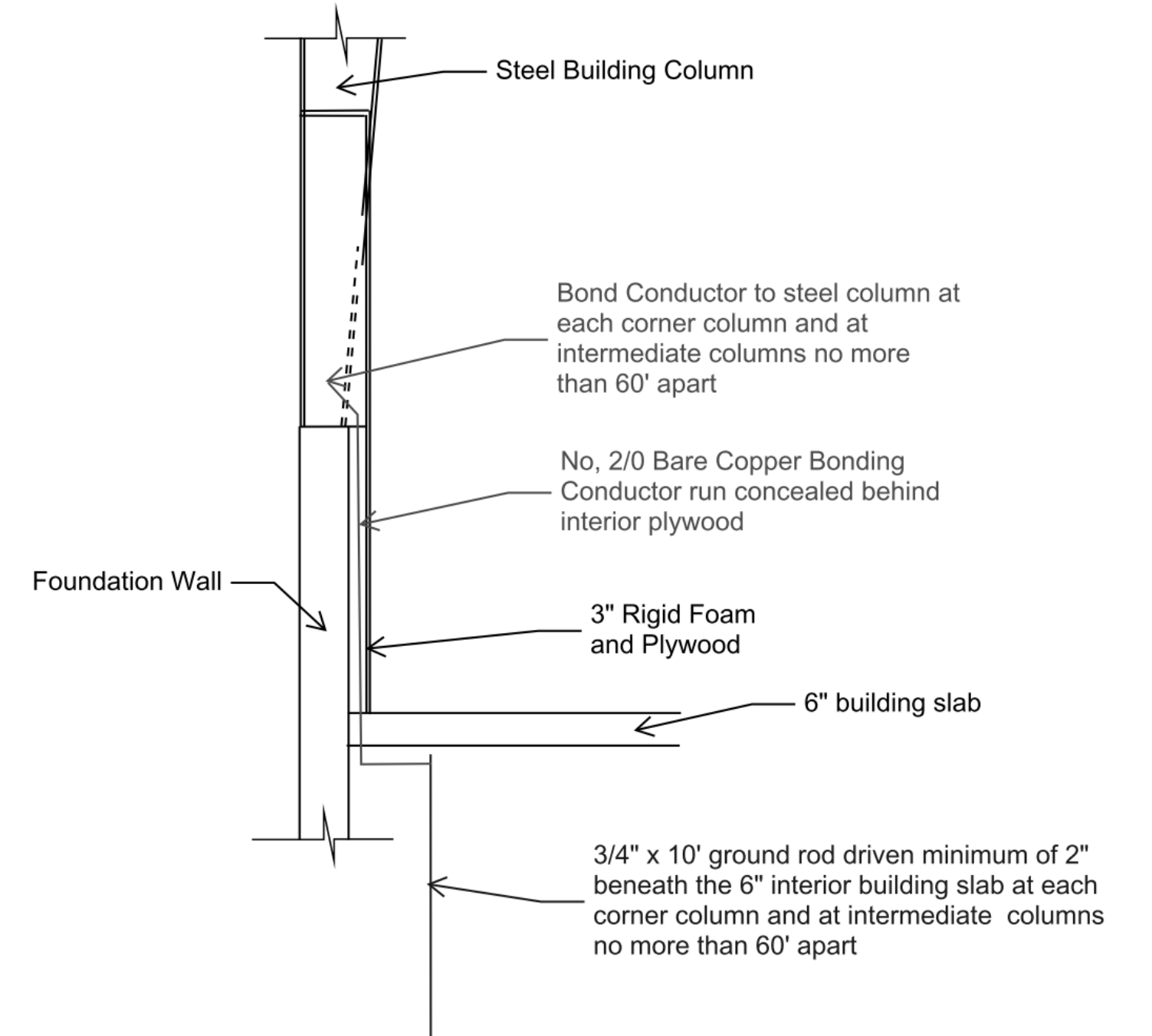

A1 ELECTRICAL SCHEDULES **A7 ELECTRICAL GROUNDING DETAIL**

Scale:

No.	Revision	By	Date
1	ADDENDUM - 1	AEI	04/11/2024

Designed by:
 ANTHONY DAVIS, P.E.
 ISSUED FOR BID - NOT FOR CONSTRUCTION

Designed: CAF 03/25/24
 Checked: CAF 03/25/24
 Drawn: PMC 03/25/24

STATE OF MAINE
 CATHERINE A. FAUCHER
 No. 7575
 LICENSED PROFESSIONAL ENGINEER

Allied Engineering
 Structural Mechanical Electrical Plumbing
 160 Veranda Street
 Portland, Maine 04103
 P: 207.221.2269
 F: 207.221.2266
 Web: www.allied-eng.com

MAINE TURNPIKE

THE GOLD STAR MEMORIAL HIGHWAY

MTA PROJECT MANAGER: Brian A. Taddeo, P.E.

CONTRACT 2024.09
YORK VEHICLE STORAGE GARAGE
ELECTRICAL GENERAL NOTES AND SCHEDULES

SHEET NUMBER: E001
 CONTRACT: 2024.09
 30 OF 32

ELECTRICAL SCHEDULE OF MECHANICAL EQUIPMENT- REFER TO PANEL SCHEDULES FOR CIRCUITING

TAG	DESCRIPTION/ AREA SERVED	VOLTS	PH	LOAD	FLA	MCA	MOPD	DISCONNECT SWITCH			STARTER (NEMA)		CBD	WIRING IN CONDUIT (2 #12, 1#12 G UNO)	NOTES	
								FRAME	POLES	FUSE	NEMA...	FBD				SIZE/...
AC-1	AIR COMPRESSOR	230	1	7.5 HP	40	40	80	60	2		3R	22	22	22	2 #4, 1 #8G	
GUH-1	GAS UNIT HEATER	120	1	1/2 HP	9.8		20			FWE		23	23	23		
GUH-2	GAS UNIT HEATER	120	1	1/2 HP	9.8		20			FWE		23	23	23		
GUH-3	GAS UNIT HEATER	120	1	1/2 HP	9.8		20			FWE		23	23	23		
DF-1,2,3	DESTRATIFICATION FANS	120	1	106W	1.0		15			MRT		26	23	23		
EF-1	EXHAUST FAN	230	1	2 HP	12.0		25			FWE		23	23	23	3 #12, 1 #12G	
WH-1	ELECTRIC WATER HEATER	240	1	4500W	18.8		30			MRT		23	23	23	2 #10, 1 #10G	

NOTES:

ABBREVIATIONS:

- FWE FURNISHED WITH EQUIPMENT
- NF NOT FUSED
- SWBD SWITCHBOARD
- FBD FURNISHED BY DIVISION
- CBD CONTROL WIRING BY DIVISION
- MRT MOTOR RATED TOGGLE SWITCH (VOLTAGE, CURRENT RATING AND POLE QUANTITY AS REQUIRED)

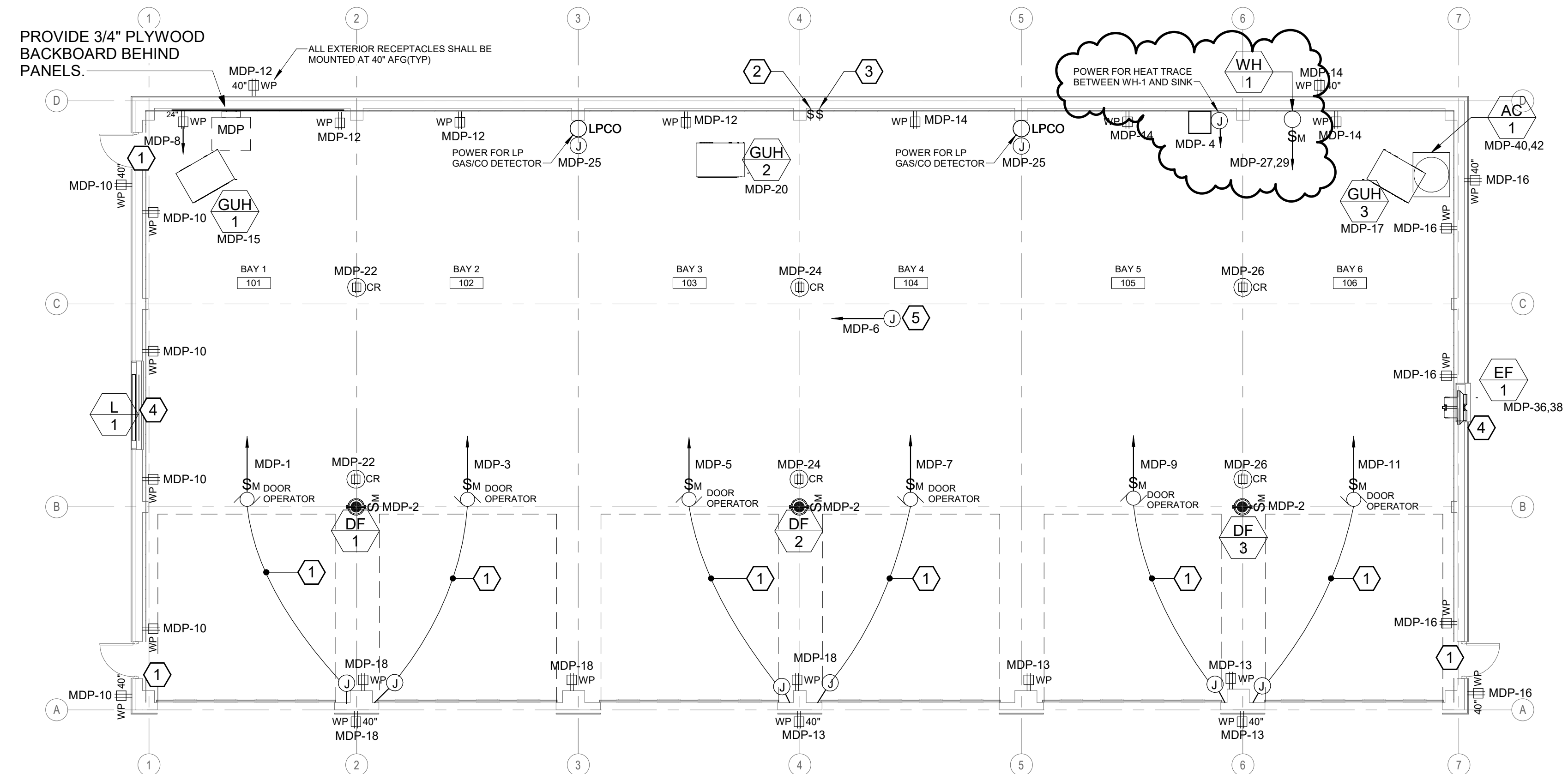

KEYED NOTES:

- 1 PROVIDE EMPTY J-BOX 44" ABOVE FINISHED FLOOR AND 1-1/2" EMPTY CONDUIT FOR DOOR CONTROLS. CONTROL WIRING AND CONTROLS BY OTHERS.
- 2 DESTRATIFICATION FAN DF-1 thru DF-3 MANUAL SPEED CONTROLS-CONTROLS BY OTHERS.
- 3 EXHAUST FAN EF-1/L-1 VENTILATION TIMER AND VARIABLE SPEED CONTROLS LOCATIONS - CONTROL DEVICES SUPPLIED BY DIVISION 23, WIRED BY DIVISION 26.
- 4 WIRE AND CONNECT L-1/L-1 THROUGH TIMER SWITCH AND VARIABLE SPEED CONTROLLER SUPPLIED BY DIVISION 23. COORDINATE WITH DIVISION 23.
- 5 PROVIDE 120 VOLT POWER FOR HVAC CONTROLS AT UNDERSIDE OF DECK. CONTROLS BY OTHERS.

A1 POWER AND SYSTEMS PLAN													
1/8" = 1'-0"													
Scale:	Designed by:	<div style="display: flex; justify-content: space-between; align-items: center;"> <div style="text-align: center;"> <p>CATHERINE A. FAUCHER No. 7575 LICENSED PROFESSIONAL ENGINEER</p> </div> <div style="text-align: center;"> <p>Allied Engineering Structural Mechanical Electrical Plumbing 160 Veranda Street Portland, Maine 04103 P: 207.221.2269 F: 207.221.2266 Web: www.allied-eng.com</p> </div> <div style="text-align: center;"> </div> </div>											
<table border="1" style="width: 100%; border-collapse: collapse;"> <thead> <tr> <th>No.</th> <th>Revision</th> <th>By</th> <th>Date</th> </tr> </thead> <tbody> <tr> <td>1</td> <td>ADDENDUM - 1</td> <td>AEI</td> <td>04/11/2024</td> </tr> </tbody> </table>				No.	Revision	By	Date	1	ADDENDUM - 1	AEI	04/11/2024	ANTHONY DAVIS, P.E. ISSUED FOR BID - NOT FOR CONSTRUCTION	
No.	Revision	By	Date										
1	ADDENDUM - 1	AEI	04/11/2024										
<table border="1" style="width: 100%; border-collapse: collapse;"> <thead> <tr> <th>By</th> <th>Date</th> <th>Checked:</th> <th>By</th> <th>Date</th> </tr> </thead> <tbody> <tr> <td>CAF</td> <td>03/25/24</td> <td>CAF</td> <td>CAF</td> <td>03/25/24</td> </tr> </tbody> </table>		By	Date	Checked:	By	Date	CAF	03/25/24	CAF	CAF	03/25/24	AEI PROJ.NO.: 20020 CAD FILE: MTA PROJECT MANAGER: Brian A. Taddeo, P.E.	
By	Date	Checked:	By	Date									
CAF	03/25/24	CAF	CAF	03/25/24									
		CONTRACT 2024.09 YORK VEHICLE STORAGE GARAGE POWER AND SYSTEMS PLAN SHEET NUMBER: EP100 CONTRACT: 2024.09 32 OF 32											

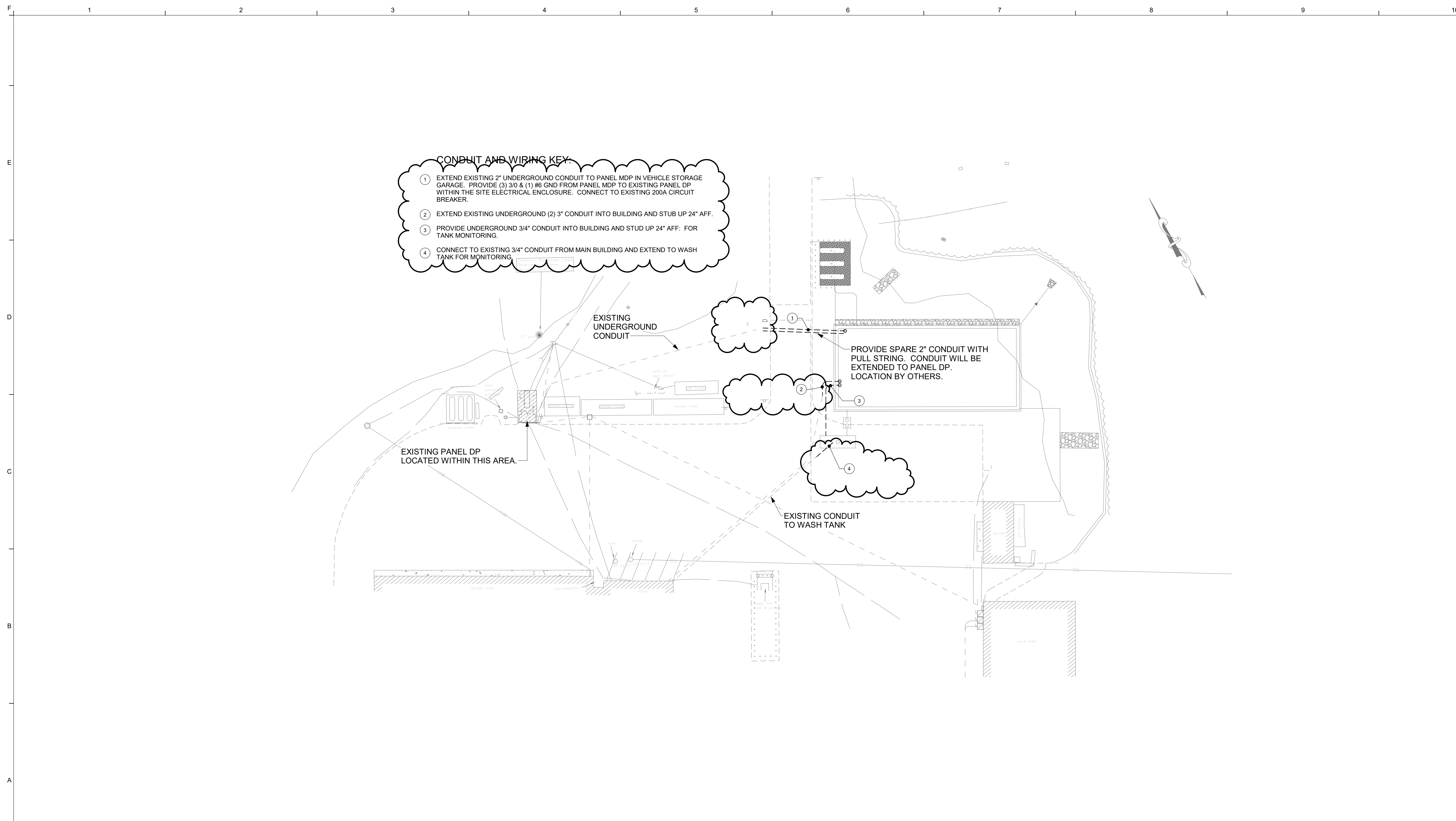

A1 ELECTRICAL SITE PLAN

1" = 30'-0"

Scale:
1" = 30'-0"

Designed by:
ANTHONY DAVIS, P.E.

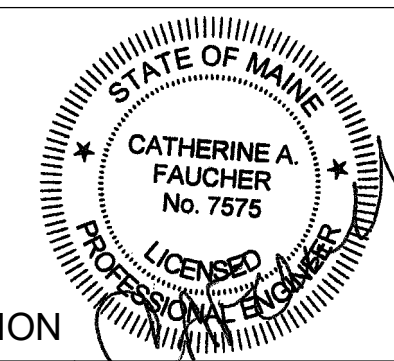

Allied Engineering
Structural Mechanical Electrical Plumbing
160 Veranda Street
Portland, Maine 04103
P: 207.221.2260
F: 207.221.2266
Web: www.allied-eng.com



**THE GOLD STAR
MEMORIAL HIGHWAY**

**CONTRACT 2024.09
YORK VEHICLE STORAGE GARAGE
ELECTRICAL SITE PLAN**

No.	Revision	By	Date
1	ADDENDUM - 1	AEI	04/11/2024

ISSUED FOR BID - NOT FOR CONSTRUCTION

By	Date	Checked:	By	Date
CAF	03/25/24	CAF	CAF	03/25/24

Drawn: PMC 03/25/24

AEI PROJ.NO.: 20020 CAD FILE:

MTA PROJECT MANAGER: Brian A. Taddeo, P.E.

CONTRACT: 2024.09 SHEET NUMBER: ES100 28 OF 32