

MAINE TURNPIKE AUTHORITY

ADDENDUM NO. 2

CONTRACT 2022.08

LITCHFIELD 8-BAY GARAGE REPLACEMENT

MILE 92.7

The bid opening date is Tuesday March 29, 2022 at 11:00 am.

The following changes are made to the Proposal, Specifications and Plans.

SPECIFICATIONS

The following changes are hereby incorporated into the project Special Provisions:

- Section 604 – Manholes, Inlets and Catch Basins: This section is deleted in its entirety and replaced with Section 604 – Manholes, Inlets and Catch Basins, attached hereto with revisions.
- Section 800.02 – General: Delete the 1st sentence of the 4th paragraph and replace with: “*The work includes all building structure, mechanical, electrical, plumbing, and all other work incidental thereto in accordance with the Plans and Specifications.*” Make this change in pen and ink.
- Section 233113 – Ductwork: This section is deleted in its entirety and replaced with Section 233113 – Ductwork, attached hereto with revisions.

PLANS

The following changes are hereby incorporated into the project Plans:

- Plan Sheet 2 – General Notes, Earthwork Note 12 is deleted and replaced with the following:

12. The Maine Turnpike owns a stockpile of approximately 300 cubic yards of common fill material at the Litchfield Maintenance yard. The contractor will be permitted to use this fill material for construction of the proposed berm at the northwest corner of the project site. Payment will be made as common excavation.
- Plan Sheet 4 – Site & Utility Plan: **DELETE** the sheet and **REPLACE** it with, Plan Sheet 4, attached hereto with revisions.
- Plan Sheet 5 – Grading, Drainage, & Erosion Control Plan: **DELETE** the sheet and **REPLACE** it with, Plan Sheet 5, attached hereto with revisions.
- Plan Sheet 7 – Details Sheet 2: **DELETE** the sheet and **REPLACE** it with, Plan Sheet 7, attached

hereto with revisions.

- Plan Sheet 9 – Oil/Water Separator Detail: **DELETE** the sheet and **REPLACE** it with, Plan Sheet 9, attached hereto with revisions.
- Plan Sheet 18 – Details: **DELETE** the sheet and **REPLACE** it with, Plan Sheet 18, attached hereto with revisions.

QUESTIONS

The following are questions submitted to the Maine Turnpike Authority in writing. Answers to the questions are noted. Bidders shall utilize this information in preparing their bid.

Question 1: Sheet A7 Details shows kicker wall insulation as 2" R-10. Wall Sections on A5 show it as R-15 insulation. Which is correct?

Answer: R-15 is correct. The proposed changes to sheet 18 (A-7) included in this Addendum address this question.

Question 2: Looking for louver specifications for L-1 on drawing 25 (Mechanical Plan)?

Answer: The proposed changes to specification 233113 – Ductwork address this question.

Question 3: Will hot rubber joint sealant be required for surface pavement joints?

Answer: No.

Question 4: Can you clarify the basis of payment for Disposal/Treatment of Special Excavation? Specifically, is excavation of contaminated soils incidental to this item or is it covered under Common Excavation? Or, is this just stockpiling and hauling the contaminated soils to an approved facility? Are placing, grading and compacting of replacement materials also incidental to this item?

Answer: Excavation of soil will be measured and paid for as common excavation. If contaminated soils are encountered during construction, material excavated will be subject to specification 203 including stockpiling of materials as described. Item 203.2333 basis of payment includes excavation from contaminated stockpile, loading, treatment, placing, grading, and compacting. Placing, grading, and compacting are included for contaminated soils that are characterized as 'lightly contaminated', as defined in the specifications, in which case placement from stockpile would be paid under item 203.2333.

Question 5: Earthwork Note #12 refers to payment under Common Borrow construction of the proposed berm at the northwest corner of the project site. The bid form does not have a Common Borrow item. Is this work incidental to another item?

Answer: The change to Sheet 2, Earthwork Note #12 included in this addendum addresses

this question.

Question 6: Can you clarify the Removing Pavement item? Section 203.01 in the specifications mentions removal and disposal of full depth existing pavement. What does the quantity of 55 SY refer to? I assume that all of the existing pavement within the sawcut lines will be removed, which is more than 55 SY. Is this work paid under the Common Excavation item?

Answer: Existing pavement removed within the sawcut is paid under Common Excavation. The 55 SY of Item 202.202 Removing Pavement Surface includes only the 1' wide, 1-1/2" milling step around the perimeter of the sawcut per the pavement sawcut detail on sheet C-403 (8/35).

Question 7: Special Provision Section 800 addresses the Storage Garage Construction. The General description of work is to include "...all site work, grading, pavement, lighting, utilities, and all other work incidental thereto in accordance with the plans and specifications". The Method of Measurement states that all earthwork required for building construction will be paid separately under the respective pay items. Are there any earthwork items incidental to the building construction that should be included in Pay Item 800.01 (ex. foundation drain, etc.)?

Answer: The changes made to Special Provision 800 included in this addendum address this question.

Question 8: On sheet C-102, What is the purpose of the line with a "C" on it. – See left hand side of the page. Is it a clearing limit?

Answer: The C linestyle on sheet C-102 is the limits of grading and indicates a location of cutting/excavation. There is a small area of clearing also shown at the underdrain outlet location to the west of the proposed building with the CLL linestyle (clearing limit line).

Question 9: Will we need to provide a laptop workstation for access to the BAS?

Answer: This project does not require a new BAS or any hardware associated with a new BAS or front end. A Building Automation System front end currently exists within the existing Maintenance Garage. As outlined in Specification Section 230900, the intent of this project is only to relocate the existing booster pump control components from the temporary water shed to the new 8-Bay, extend monitoring of the existing relocated water treatment system to the new 8-Bay, and ADD a low level alarm for the existing underground water storage tank, integrated with the existing BAS.

Question 10: Based on 230900-1 1.1 B, the intention is that this new controls work will NOT integrate into the existing BAS. Can we confirm this? The preceding paragraph seems to contradict the previous verbiage by stating that these new controls will be provided as an extension to the BAS.

Answer: The interpretation above is not correct. Paragraph 1.1 B refers to temperate controls only. There is no requirement for integration of the temperature control system in the new 8-Bay with the BAS. It is stand-alone. The only integration will be for the domestic water treatment system monitoring and booster pump control, which currently exist and are to be restored/relocated under the project scope, and a new low level alarm for the water storage tank.

Question 11: For the existing booster pump, the DDC contractor is expected to demolish existing wiring and replace with new wire runs to the 8 Bay Garage. Is it safe to assume that the pump has existing control peripheral devices that we will keep?

Answer: Yes, the booster pump is currently operating. Existing components shall be retained.

Question 12: Is the intention for the DDC contractor to provide damper & damper actuator for the louvers? Typically the DDC Contractor will provide the actuator only.

Answer: The dampers and actuators shall operate through a stand-alone controller. The contract does not dictate which trade furnishes and installs the dampers and actuators. We consider that contractor means and methods.

Question 13: Will the DDC contractor be responsible to provide all VFD's on site? Including the VFD controller for EF-1 and Destratification fans?

Answer: It is not our intent to dictate which trade furnishes and installs the individual components. We consider that means and methods of the contract.

Question 14: Can we get confirmation that the gas heating GUH's will come with their own control valves?

Answer: Yes, the heaters are specified to include a single stage gas valve. The appliance regulator, however, is specified separately.

Question 15: According to 23 09 23, the Destratification fans and EF-1 will be operated by a speed wall switch. Will the DDC system also have the ability to turn on/off the fans through the BAS?

Answer: No, there is no requirement for BAS interface.

Question 16: Is the intention that the pressure controller (provided with the air compressor) be integrated into the BAS for monitoring and trending?

Answer: No this is not required.

Question 17: Under 235533-5 Figure 13-1, will the DDC contractor be responsible to furnish any of the

control devices under that drawing? Relays, thermal switches, emergency switch, etc.

Answer: Again, although it is not our intent to delegate the work, traditionally, this work is completed by the burner technician and Division 26.

Question 18: Can we get confirmation that the MOD's for the louvers will be modulating?

Answer: No, the MOD's at the intake louver and exhaust fan are two position dampers.

ATTACHMENTS

- Addendum No. 2 (5 pages)
- Revised Specifications (16 page)
- Revised Plan Sheets (5 pages)

Notes: The above items shall be considered as part of the bid submittal.

The total number of pages included with this addendum is 26 pages.

All bidders are requested to acknowledge the receipt of the Addendum No. 2 by signing below and faxing this sheet to Nathaniel Carll, Purchasing Department, Maine Turnpike Authority at (207) 871-7739. Bidders are also required to acknowledge receipt of this Addendum No. 2 on Page P-7 of the bid package.

Business Name

Print Name and Title

Signature

Date

Very truly yours,

MAINE TURNPIKE AUTHORITY

Nathaniel Carll Purchasing Department Maine Turnpike
Authority

SPECIAL PROVISION

SECTION 604

MANHOLES, INLETS AND CATCH BASINS

(6,000 Gallon Holding Tank)
(Oil/Water Separator)

The provisions of Section 604 of the MaineDOT Standard Specifications and the Maine Turnpike Authority 2016 Supplemental Specifications shall apply with the following additions and modifications:

604.01 Description

This work shall consist of designing, detailing, furnishing and installing an H-20 rated holding tank and oil-water separator system consistent with the details presented in the contract Plans. The holding tank shall have a liquid capacity of at least 6,000 gallons and conform to the applicable requirements of ASTM C478. The tank shall be constructed of concrete with a minimum compressive strength of 5,000 psi at 28 days and use either wire fabric reinforcing meeting the requirements of ASTM A185 or deformed steel reinforcement meeting the requirements of ASTM A615. Reinforcing shall have a minimum yield strength of 40,000 psi.

The oil-water separator system shall consist of a precast oil-water separator structure, pipes, and two (2) precast manholes required to provide a complete functioning system as generally shown on the plans or as approved by the Resident. The system shown on the plans is for informational purposes only; the dimensions and elevations shown may be adjusted with the approval of the Resident.

The work shall also include construction of a new 4' long by 4' wide x 10" thick reinforced concrete slab fabricated in accordance with Section 502 Structural Concrete. The concrete slab shall be installed around an 18" Universal Model 98 – Multi-Purpose Manhole (or approved equal).

The work shall also include the application of a Clear Protective Coating for Concrete Surfaces to the top and vertical surfaces of the concrete slab prior to backfilling and paving.

The work shall also include furnishing and installing a weatherproof junction box (16 cubic inch minimum) to terminate a proposed empty 1" PVC conduit inside the 18" manhole. 1" PVC conduit to be measured and paid under item 655.2002 1" Schedule 80 PVC Conduit.

All joints shall be watertight and sealed with Tylox superseal rubber gasket or equivalent.

The Contractor shall provide a licensed tank installer for the installation of both the Oil/Water Separator and the Holding Tank in accordance with Maine Department of Environmental Protection requirements.

The work shall also consist of submitting all required paperwork to the Maine Turnpike Authority for permitting and registration with MaineDEP Underground Oil Storage Tank (UST) Facilities. UST registration paperwork shall be submitted to the Authority 4 weeks prior to installation to allow review by the Authority and submission to MaineDEP at least 10 business days prior to installation as required by state regulations.

Layout design and Shop Drawings for both the Holding Tank and the Oil/Water Separator shall be completed, submitted to, and accepted by the Resident or the MTA prior to any work being completed relative to this section.

604.011 Oil/Water Separator Description:

The Oil/Water Separator shall meet the requirements listed herein:

- The Oil/Water separator shall perform its intended function and have pipe inlets/outlets within reasonable conformity with the special grading detail shown in the contract documents.
- Provide 30" diameter frame and cover on top of the structure with shiplap joints.
- Concrete: 5,000 PSI @ 28 days.
- Cement shall be type III per ASTM C150-81
- Reinforcing: Grade 60 Per ASTM A615.
- Design Loading: H-20 per ASTM C-478.
- Joints to be sealed watertight with Con-seal or an approved equal fabricated of rubber per ASTM C443 or a double bitumastic seal per ASTM C990
- Provide inlet/outlet pipe boots to fit 6" PVC pipe.
- Provide PVC riser boot to fit 4" PVC pipe.
- PVC Pipe shall meet the requirements of Subsection 706.08
- The structure shall have a sealant applied inside or outside to provide waterproofing of the complete unit.

Preferred Oil/Water Separator that meets the requirements listed above:

- The George R. Roberts H-20 Oil/Water Separator.

604.02 Materials

The frame, cover, and risers be 18" and 30" in diameter (See details in the plans) for the 6,000-gallon holding tank as well as the oil/water separator. The 18" manhole shall be a Universal Model 98 – Multi-Purpose Manhole and cover or approved equal.

All frames and covers shall be cast iron conforming to the requirements of AASHTO M105 for Class No. 30 gray iron castings suitable for H-20 loading. Frames and covers shall be machined to ensure true bearing surfaces. Cover(s) for the oil-water separator shall be cast with the word

"O/W SEP" on it. Frame flanges shall have a minimum four-inch width. Casting for oil-water separator shall have a minimum 30-inch clear opening.

The weatherproof junction box shall have a minimum volume of 16 cubic inches.

The concrete pad shall conform to Special Provision 502 Structural Concrete.

The holding tank and oil/water separator shall be designed in accordance with the drawings shown in the plans or shall be an approved equal.

604.05 Method of Measurement

The 6,000 gallon holding tank will be measured as one unit furnished, installed and accepted complete-in-place, including required permitting, reinforced concrete pad, weatherproof junction box, and 4" PVC riser.

The Oil/Water Separator will be measured as one unit furnished, installed and accepted complete-in-place, including required permitting.

604.06 Basis of Payment

The accepted quantities will be paid for at the contract unit price each for the respective types complete, in place, and accepted. Payment will be full compensation for furnishing and placing bedding, excavation, backfill, compaction, and all labor and equipment necessary to complete the work.

Payment will be made under:

<u>Pay Item</u>		<u>Pay Unit</u>
604.158	6000 Gallon Holding Tank	Each
604.40	Oil/Water Separator	Each

SECTION 233113 - DUCTWORK

PART 1 - GENERAL

1.1 RELATED SECTIONS

- A. Drawings and general provisions of the Contract, including General and Supplementary Conditions apply to this Section.
- B. Related Sections include the following:
 - 1. Division 8 for Access Doors
 - 2. Division 23 Section "Common Work Results for Mechanical"
 - 3. Division 23 Section "Mechanical Insulation"
 - 4. Division 23 Section "Sequence of Operations"
 - 5. Division 23 Section "Testing, Adjusting, and Balancing".

1.2 SUMMARY

- A. This Section includes ducts and accessories.

1.3 SYSTEM DESCRIPTION

- A. Drawings show the general layout of ductwork and accessories but do not show all required fittings and offsets that may be necessary to connect ducts to equipment, diffusers, grilles, etc., and to coordinate with other trades. Fabricate ductwork based on field measurements. Provide all necessary fittings and offsets. Coordinate with other trades for space available and relative location of HVAC equipment and accessories on ceiling grid. Duct sizes on the drawings are inside dimensions, which may be altered by Contractor to other dimensions with the same air handling characteristics where necessary to avoid interferences and clearance difficulties.
- B. The contractor must comply with the enclosed specification in its entirety. If on inspections, the engineer finds changes have been made without prior written approval, the contractor will make the applicable changes to comply with this specification, at the contractor's expense.
- C. At the discretion of the engineer, sheet metal gauges, and reinforcing may be randomly checked to verify all duct construction is in compliance.

1.4 PERFORMANCE REQUIREMENTS

- A. Delegated Duct Design: Duct construction, including sheet metal thicknesses, seam and joint construction, reinforcements, and hangers and supports, shall comply with SMACNA's "HVAC Duct Construction Standards - Metal and Flexible" and performance requirements and design criteria indicated in "Duct Schedule" Article.

- B. Structural Performance: Duct hangers and supports and seismic restraints shall withstand the effects of gravity and seismic loads and stresses within limits and under conditions described in SMACNA's "HVAC Duct Construction Standards - Metal and Flexible", ASCE/SEI 7, and SMACNA's "Seismic Restraint Manual: Guidelines for Mechanical Systems."
- C. Airstream Surfaces: Surfaces in contact with the airstream shall comply with requirements in ASHRAE 62.1. Exception: Sheet metal surfaces and fasteners.

1.5 ACTION SUBMITTALS

- A. Product Data: For each type of the following products:
 - 1. Sealants and gaskets.
 - 2. Seismic-restraint devices.
- B. Shop Drawings:
 - 1. Fabrication, assembly, and installation, including plans, elevations, sections, components, and attachments to other work.
 - 2. Factory- and shop-fabricated ducts and fittings.
 - 3. Fittings.
 - 4. Reinforcement and spacing.
 - 5. Seam and joint construction.
 - 6. Penetrations through fire-rated and other partitions.
 - 7. Equipment installation based on equipment being used on Project.
 - 8. Hangers and supports, including methods for duct and building attachment, seismic restraints, and vibration isolation.
- C. Delegated-Design Submittal:
 - 1. Sheet metal thicknesses.
 - 2. Joint and seam construction and sealing.
 - 3. Reinforcement details and spacing.
 - 4. Materials, fabrication, assembly, and spacing of hangers and supports.
- D. Ductwork Specialties Product Data; provide for the following:
 - 1. Sealant
 - 2. Duct-mounted access doors and panels.
 - 3. Flexible ducts.
 - 4. Backdraft dampers.
 - 5. Manual-volume dampers: Damper manufacturer's printed application and performance data including pressure, velocity and temperature limitations shall be submitted for approval.

1.6 INFORMATIONAL SUBMITTALS

- A. Field Test Reports: Indicate and interpret test results for compliance with performance requirements.

- B. Record Drawings: Indicate actual routing, fitting details, reinforcement, support, and installed accessories and devices.

1.7 CLOSEOUT SUBMITTALS

- A. Operation and Maintenance Data: For air duct accessories to include in operation and maintenance manuals.

1.8 APPLICABLE PUBLICATIONS

- A. The publications listed below form a part of this specification to the extent referenced. The publications are referenced in the text by the basic designation only.
- B. ASHRAE Compliance: Applicable requirements in ASHRAE 62.1, Section 5 - "Systems and Equipment" and Section 7 - "Construction and System Start-up."
- C. National Fire Protection Association (NFPA)
 - 1. 90A: Standard for the Installation of Air Conditioning and Ventilating Systems
- D. Sheet Metal and Air Conditioning Contractors National Association (SMACNA):
 - 1. 3rd Edition: 2005 HVAC Duct Construction Standards, Metal and Flexible
 - 2. 1st Edition: 2012 ANSI/SMACNA 016-2012 HVAC Air Duct Leakage Test Manual

1.9 DELIVERY, STORAGE, AND HANDLING

- A. Deliver sealant and fire stopping materials to site in original unopened containers or bundles with labels indicating manufacturer, product name and designation, color, expiration period for use, pot life, curing time, and mixing instructions for multi-component materials.
- B. Deliver, store and handle materials according to manufacturer's written recommendations.
- C. All ductwork, equipment, and fittings delivered and stored on the job site must be capped to prevent the entry of moisture, construction dust or other debris.

PART 2 - PRODUCTS

2.1 SHEET METAL MATERIALS

- A. General Material Requirements: Comply with SMACNA's "HVAC Duct Construction Standards - Metal and Flexible" for acceptable materials, material thicknesses, and duct construction methods unless otherwise indicated. Sheet metal materials shall be free of pitting, seam marks, roller marks, stains, discolorations, and other imperfections.

- B. Galvanized Sheet Steel: Comply with ASTM A 653/A 653M. Galvanized Coating Designation: G60 or G90 as indicated. Finishes for Surfaces Exposed to View: Mill phosphatized.
- C. Carbon-Steel Sheets: Comply with ASTM A 1008/A-1008M, with oiled, matte finish for exposed ducts.
- D. Reinforcement Shapes and Plates: ASTM A-36/A-36M, steel plates, shapes, and bars; black and galvanized.
- E. Tie Rods: Galvanized steel, 1/4-inch minimum diameter for lengths 36 inches or less; 3/8-inch minimum diameter for lengths longer than 36 inches.

2.2 SINGLE-WALL RECTANGULAR DUCTS AND FITTINGS

- A. General Fabrication Requirements: Comply with SMACNA's "HVAC Duct Construction Standards - Metal and Flexible" based on indicated static-pressure class unless otherwise indicated.
- B. Transverse Joints: Select joint types and fabricate according to SMACNA's "HVAC Duct Construction Standards - Metal and Flexible," Figure 2-1, "Rectangular Duct/Transverse Joints," for static-pressure class, applicable sealing requirements, materials involved, duct-support intervals, and other provisions in SMACNA's "HVAC Duct Construction Standards - Metal and Flexible."
- C. Longitudinal Seams: Select seam types and fabricate according to SMACNA's "HVAC Duct Construction Standards - Metal and Flexible," Figure 2-2, "Rectangular Duct/Longitudinal Seams," for static-pressure class, applicable sealing requirements, materials involved, duct-support intervals, and other provisions in SMACNA's "HVAC Duct Construction Standards - Metal and Flexible."
- D. Cross Breaking or Cross Beading: Cross break or cross bead duct sides 19 inches and larger and 0.0359 inch thick or less, with more than 10 sq. ft. of un-braced panel area, unless ducts are lined. All large ducts must be braced as required to prevent drumming.
- E. Elbows, Transitions, Offsets, Branch Connections, and Other Duct Construction: Select types and fabricate according to SMACNA's "HVAC Duct Construction Standards - Metal and Flexible," Chapter 4, "Fittings and Other Construction," for static-pressure class, applicable sealing requirements, materials involved, duct-support intervals, and other provisions in SMACNA's "HVAC Duct Construction Standards - Metal and Flexible."
 - 1. Fig. 2-3 Rectangular Elbows: Type RE2 square throat with vanes, Type RE1 radius (1.5W minimum), or Type RE5 dual radius. Square throat is not allowed.
 - 2. Vane support in elbows: Fig 2-4. Turning vanes shall be Harper double wall turning vanes fabricated from the same material as the duct. Mounting rails shall have friction insert tabs that align the vanes automatically. Tab spacing shall be as specified in Figure 2-3 of the 1995 SMACNA Manual, "HVAC Duct Construction Standards, Metal & Flexible" Second Edition standard. Rail systems with non-standard tab spacing shall not be accepted. Due to tensile loading, vanes shall be capable of supporting 250 pounds when secured according to the manufacturer's instructions.

3. Fig. 2-5 Rectangular Divided Flow Branches: Type 1, Type 2, Type 4A, or 4B.
4. Fig. 2-6 Branch Connections: 45-degree entry, 45-degree lead-in, bell-mouth or spin-in (single diffuser supply only).
5. Fig. 2-7 Offsets and Transitions. Use gradual offsets as shown, 90-degree offsets shall be avoided.
6. Fig 2-9 Duct Coils: Duct coils with transitions and upstream access door as shown.

2.3 ROUND DUCT FABRICATION

- A. Fabricate supply ducts of galvanized steel according to SMACNA's "HVAC Duct Construction Standards--Metal and Flexible" latest edition.
- B. Longitudinal Seams: Select seam types and fabricate according to SMACNA's "HVAC Duct Construction Standards - Metal and Flexible," Figure 3-2, "Round Duct Longitudinal Seams," for static-pressure class, applicable sealing requirements, materials involved, duct-support intervals, and other provisions in SMACNA's "HVAC Duct Construction Standards - Metal and Flexible."
 1. Exposed Round Ducts: Shall be Spiral Seam (RL-1 seam) at 2-inch wg construction.
 2. Concealed Round Ducts: Shall be longitudinal Grooved Seam Flat lock (RL-5 seam) at 2-inch wg construction.
 3. Snap lock seams shall not be used for this project.
- C. Transverse Joints: Select joint types and fabricate according to SMACNA's "HVAC Duct Construction Standards - Metal and Flexible," Figure 3-1, "Round Duct Transverse Joints," for static-pressure class, applicable sealing requirements, materials involved, duct-support intervals, and other provisions in SMACNA's "HVAC Duct Construction Standards - Metal and Flexible."

2.4 HANGERS AND SUPPORTS

- A. Hanger Rods: Cadmium-plated steel rods and nuts.
- B. Hanger Rods for Outdoor Environments: Electrogalvanized, all-thread rods or galvanized rods with threads painted with zinc-chromate primer after installation.
- C. Strap and Rod Sizes: Comply with SMACNA's "HVAC Duct Construction Standards - Metal and Flexible," Table 5-1, "Rectangular Duct Hangers Minimum Size," and Table 5-2, "Minimum Hanger Sizes for Round Duct."
- D. Steel Cables for Galvanized-Steel Ducts: Galvanized steel complying with ASTM A-603. Steel Cable End Connections: Cadmium-plated steel assemblies with brackets, swivel, and bolts designed for duct hanger service; with an automatic-locking and clamping device.
- E. Duct Attachments: Sheet metal screws, blind rivets, or self-tapping metal screws; compatible with duct materials.
- F. Trapeze and Riser Supports:

1. Supports for Galvanized-Steel Ducts: Galvanized-steel shapes and plates.
2. Supports for Stainless-Steel Ducts: Stainless-steel shapes and plates.
3. Supports for Aluminum Ducts: Aluminum or galvanized steel coated with zinc chromate.

2.5 SEALANT MATERIALS

- A. Joint Sealant/Mastic: Shall be flexible, water-based, adhesive sealant designed for use in all pressure duct systems. After curing, it shall be resistant to ultraviolet light and shall prevent the entry of water, air and moisture into the duct system. Sealer shall be UL 723 listed; UL 181A-M or 181B-M listed; and meet NFPA 90A requirements. Pressure sensitive tape shall not be used as a sealing mechanism.
 1. Maximum 5 flame spread and 0 smoke-developed (ASTM E-84 Tunnel Test).
 2. Generally provide liquid sealant for low clearance slip joints and heavy, permanently elastic, mastic type where clearances are larger.
 3. Resistance to mold, mildew and water: Excellent
 4. Color: Gray
- B. Flange Gaskets: Butyl rubber, neoprene, or EPDM polymer with polyisobutylene plasticizer.
- C. Round Duct Joint O-Ring Seals: Seal shall provide maximum leakage class of 3 cfm/100 sq. ft. at 1-inch wg and shall be rated for 10-inch wg static-pressure class, positive or negative. Double-lipped, EPDM O-ring seal, mechanically fastened to factory-fabricated couplings and fitting spigots.

2.6 FITTINGS

- A. Tees, Laterals, and Conical Tees: Use 45 degree; fabricate to comply with SMACNA's "HVAC Duct Construction Standards--Metal and Flexible," with metal thicknesses specified for longitudinal seam straight duct.
- B. Diverging-Flow Fittings: Fabricate with a reduced entrance to branch taps with no excess material projecting from body onto branch tap entrance.
- C. Elbows: Diameters 3 through 8 inches shall be two-section die stamped; all others shall be gored construction, maximum 18 degree angle, with all seams continuously welded or standing seam. Coat galvanized areas of fittings damaged by welding with corrosion resistant aluminum paint or galvanized repair compound.
- D. Low-point drains: Ductmate moisture drain with funnel collection design; 3/4" connection with drain fitting and cap.

2.7 DUCT-MOUNTED ACCESS DOORS

- A. Manufacturers: Subject to compliance with requirements, provide products by one of the following:
 1. Ductmate Industries, Inc.

2. Greenheck Fan Corporation.
3. McGill Air Flow LLC.
4. Nailor Industries Inc.
5. Durodyne
6. Cesco
7. Buckley

B. Duct-Mounted Access Doors: Fabricate access panels according to SMACNA's "HVAC Duct Construction Standards - Metal and Flexible"; Figures 2-10, "Duct Access Doors and Panels," and 2-11, "Access Panels - Round Duct."

1. Door: Double wall, rated for up to 4.5" static pressure. Door panel filled with 1" fiberglass insulation; ¾ lb. density. Hinges and Latches: 1-by-1-inch continuous piano hinge and cam latches. Fabricate doors airtight and suitable for duct pressure class.
2. Frame: Galvanized sheet steel, with bend-over tabs.
3. Provide 1/8" thick neoprene gaskets.
4. Locks: Access doors less than 16 Inches Square: Two cam locks. Doors over 16" shall have four locks.

2.8 FLEXIBLE CONNECTORS

- A. Provide for all air moving equipment. General: Flame-retarded or noncombustible fabrics, coatings, and adhesives complying with UL 181, Class 0 or 1. Factory fabricated with a strip of fabric 3-1/2 inches wide attached to two strips of 2-3/4-inch- wide, 0.028-inch- thick, galvanized, sheet steel or 0.032-inch aluminum sheets. Select metal compatible with connected ducts. Duro-Dyne, Hardcast, or approved equal.
- B. Indoor Flexible Connector Fabric: Glass fabric double coated with polychloroprene or neoprene. Minimum Weight: 26 oz. /sq. yd. Tensile Strength: 480 lbf/inch in the warp, and 360 lbf/inch in the filling.

2.9 LOUVERS

- A. **Manufacturers: Subject to compliance with requirements, provide products by one of the following:**
1. **Ruskin Company**
 2. **American Warming and Ventilating, Inc.**
 3. **Greenheck.**
 4. **Arrow United Industries.**
 5. **Cesco Products.**
 6. **Construction Specialties, Inc.**
- B. **Louvers shall be AMCA Licensed. Louvers shall comply with recommendations in SMACNA's "Architectural Sheet Metal Manual" for fabrication, construction details, and installation procedures.**
- C. **Louvers shall be AMCA Certified in accordance with AMCA 511.**

- D. Intake Louvers: Water penetration tested in accordance with AMCA 500-L.**
- E. Ruskin ELF445DX: Stationary Louver with a 4" deep frame, drainable blades and a 45 degree blade angle; 52% free area; high performance frame system with a drainable head that collects and removes water for excellent water penetration performance; drain gutters in blades to minimize water cascading, architecturally styled, hidden mullions allowing continuous line appearance up to 120". Material: Extruded aluminum, Alloy 6063-T6.**
- F. Superior Performing Organic Coatings System: Manufacturer's standard multi-coat superior performing organic coatings system complying with AAMA 2605, including at least 70 percent polyvinylidene fluoride (PVDF) resin, and at least 80 percent of aluminum extrusion and panels surfaces having minimum total dry film thickness (DFT) of 1.2 mils, 0.0012 inch. Primer: Zinc chromate, alkyd type.**
- G. Accessories**
 - 1. Aluminum Insect Screen - 18-16 mesh, mill finish, .011-inch wire.**
 - 2. Bird Screen: aluminum, 5/8" mesh, removable frame, re-wireable.**
 - 3. Sealant for Setting Sills and Sill Flashing: Non-curing butyl type.**

PART 3 - EXECUTION

3.1 DUCT INSTALLATION, GENERAL

- A. Drawings show the general layout of ductwork and accessories but do not show all required fittings and offsets that may be necessary to connect ducts to equipment, diffusers, grilles, etc., and to coordinate with other trades. Fabricate ductwork based on field measurements. Provide all necessary fittings and offsets at no additional cost. Coordinate with other trades for space available and relative location of HVAC equipment and accessories on ceiling grid. Duct sizes on the drawings are inside dimensions which shall be altered by Contractor to other dimensions with the same air handling characteristics where necessary to avoid interferences and clearance difficulties.
- B. Provide volume dampers at all branch ducts to RGD's. If volume dampers are inadvertently not shown, contractor shall provide, the intent is to provide volume dampers at all branches.
- C. Provide ducts and accessories according to SMACNA's "HVAC Duct Construction Standards - Metal and Flexible" unless otherwise indicated.
- D. Construct and install each duct system for the specific duct pressure classification indicated.
- E. Properly seam, brace, stiffen, support and render ducts mechanically airtight. Adjust ducts to suit job conditions. Dimensions may be changed as approved, if cross sectional area is maintained.
- F. Provide ducts in lengths not less than 12 feet, unless interrupted by fittings. Provide ducts with fewest possible joints.
- G. Provide fabricated fittings for changes in directions, changes in size and shape, and connections.

- H. Provide couplings tight to duct wall surface with a minimum of projections into duct.
- I. Provide ductwork to allow maximum headroom. Provide ducts, unless otherwise indicated, vertically and horizontally, parallel and perpendicular to building lines; avoid diagonal runs. Provide ducts close to walls, overhead construction, columns, and other structural and permanent enclosure elements of building.
- J. Provide ducts with a clearance of 1 inch, plus allowance for insulation thickness.
- K. Conceal ducts from view in finished spaces. Do not encase horizontal runs in solid partitions, unless specifically indicated.
- L. Coordinate layout with suspended ceiling, lighting layouts, and similar finished work.
- M. Electrical Equipment Spaces: Route ductwork to avoid passing through transformer vaults and electrical equipment spaces and enclosures.
- N. Exterior ductwork shall have a pitch of at least 3 degrees on the top, to allow water runoff, prevent ice buildup.

3.2 INSTALLATION OF EXPOSED DUCTWORK

- A. Protect ducts exposed in finished spaces from being dented, scratched, or damaged.
- B. Hangers Exposed to View: Threaded rod and angle or channel supports.
- C. Trim duct sealants flush with metal. Create a smooth and uniform exposed bead. Do not use two-part tape sealing system. Seal duct joints to prevent dirt marks.
- D. Grind welds to provide smooth surface free of burrs, sharp edges, and weld splatter. When welding stainless steel with a No. 3 or 4 finish, grind the welds flush, polish the exposed welds, and treat the welds to remove discoloration caused by welding.
- E. Maintain consistency, symmetry, and uniformity in the arrangement and fabrication of fittings, hangers and supports, duct accessories, and air outlets.
- F. Repair or replace damaged sections and finished work that does not comply with these requirements.

3.3 MATERIALS

- A. Hangers, accessories, and dampers shall be same material as parent duct.
- B. Refer to Specification Section 230700 for sheet metal covering of rigid insulation for protection from maintenance personnel crossing insulated ductwork in mechanical spaces.
- C. All ducts shall be G60 galvanized steel except as follows:
 - 1. Louver sleeves and plenums: G90 galvanized steel.
 - 2. Exposed Ductwork: Galvaneal (ready for paint)

3. Plenums at outside louvers: G90 galvanized steel, water-tight, pitched to drain. Provide low-point drain fittings at low points.

3.4 DUCT CLASSIFICATIONS AND SEALING

A. Static-Pressure Classifications: Unless otherwise indicated, construct ducts to the following:

1. Supply duct upstream of VAV terminal units: 3 in. w.g.
2. Supply Ducts downstream of VAV terminal units: 2-inch wg.
3. Supply Ducts: 2-inch wg.
4. Supply Ducts: 3 in. w.g.
5. Return Ducts: 2-inch wg, negative pressure.
6. Exhaust Ducts: 2-inch wg, negative pressure.
7. Rooftop air handlers and RTU's: The first 20 feet of ductwork (supply and return) shall be fabricated and installed in a stiff and rigid manner, with cross bracing for minimal "drumming"; minimum 6-inch pressure class.

B. Seam And Joint Sealing

1. General: Seal duct seams and joints according to the duct pressure class indicated and as described in SMACNA's "HVAC Duct Construction Standards--Metal and Flexible."
2. Seal to SMACNA Class A; all joints, longitudinal and transverse seams, and connections in ductwork shall be securely fastened and sealed with welds, gaskets, or duct sealant. Exceptions:
 - a. Continuously welded and locking-type longitudinal joints and seams on ducts operating at less than 2 in. wg pressure classification.
 - b. Exposed exhaust or return ducts operating at less than 2 in. wg pressure classification.
 - c. Exposed supply ducts in the space that the duct serves.
3. Seal externally insulated ducts before insulation installation.

3.5 HANGER AND SUPPORT INSTALLATION

A. Comply with SMACNA's "HVAC Duct Construction Standards - Metal and Flexible," Chapter 5, "Hangers and Supports."

B. Building Attachments: Concrete inserts, powder-actuated fasteners, or structural-steel fasteners appropriate for construction materials to which hangers are being attached.

1. Where practical, install concrete inserts before placing concrete.
2. Provide powder-actuated concrete fasteners after concrete is placed and completely cured.
3. Use powder-actuated concrete fasteners for standard-weight aggregate concretes or for slabs more than 4 inches thick.

4. Do not use powder-actuated concrete fasteners for lightweight-aggregate concretes or for slabs less than 4 inches thick.
 5. Do not use powder-actuated concrete fasteners for seismic restraints.
- C. Hanger Spacing: Comply with SMACNA's "HVAC Duct Construction Standards - Metal and Flexible," Table 5-1, "Rectangular Duct Hangers Minimum Size," and Table 5-2, "Minimum Hanger Sizes for Round Duct," for maximum hanger spacing; install hangers and supports within 24 inches of each elbow and within 48 inches of each branch intersection.
- D. Support vertical ducts with steel angles or channel secured to the sides of the duct with welds, bolts, sheet metal screws, or blind rivets; support at each floor and at a maximum intervals of 16 feet.
- E. Provide upper attachments to structures. Select and size upper attachments with pull-out, tension,

3.6 DUCT ACCESSORIES INSTALLATION

- A. Provide duct accessories according to applicable details shown in SMACNA's "HVAC Duct Construction Standards--Metal and Flexible".
- B. Provide duct transitions, offsets and connections to dampers, coils, and other equipment in accordance with SMACNA Standards
- C. Adjust operable devices for proper action.
- D. Perform the following as directed by the controls contractor:
1. Installation of control devices
 2. Access doors where indicated and as required.
- E. Control Damper Installation
1. Damper submittals shall be coordinated for type, quantity, and size to ensure compatibility with sheet metal design.
 2. Duct openings shall be free of any obstruction or irregularities that might interfere with blade or linkage rotation or actuator mounting. Duct openings shall measure $\frac{1}{4}$ in. larger than damper dimensions and shall be square, straight, and level.
 3. Individual damper sections, as well as entire multiple section assemblies, must be completely square and free from racking, twisting, or bending. Measure diagonally from upper corners to opposite lower corners of each damper section. Both dimensions must be within $\frac{1}{8}$ in. of each other.
 4. Follow the manufacturer's instructions for field installation of control dampers. Unless specifically designed for vertical blade application, dampers must be mounted with blade axis horizontal.
 5. Damper blades, axles, and linkage must operate without binding. Before system operation, cycle damper after installation to ensure proper operation. On multiple section assemblies, all sections must open and close simultaneously.
 6. Provide a visible and accessible indication of damper position on the drive shaft end.

7. Support ductwork in area of damper when required to prevent sagging due to damper weight.
8. After installation of low-leakage dampers with seals, caulk between frame and duct opening to prevent leakage around perimeter of damper.

3.7 LOUVER INSTALLATION

- A. Louvers to be furnished by Division 23; mounted and installed by the contractor responsible for the outside wall construction. Ductwork shall be connected to the louvers by Division 23.**
- B. Verify louver openings by field measurements before fabrication and indicate measurements on Shop Drawings. For new construction, or where field measurements cannot be made without delaying the Work, establish opening dimensions and proceed with fabricating louvers without field measurements. Coordinate construction to ensure that actual opening dimensions correspond to established dimensions. Coordinate setting drawings, diagrams, templates, instructions, and directions for installation of anchorages that are to be embedded in concrete or masonry construction. Coordinate delivery of such items to Project site.**
- C. Installation**
 - 1. Locate and place louvers and vents level, plumb, and at indicated alignment with adjacent work.**
 - 2. Pitch horizontal ducts and plenums connected to louvers downward toward louvers not less than 1 inch in 10 feet. Connect to louver to allow drainage to exterior. Seal ducts water-tight.**
 - 3. Use concealed anchorages where possible. Provide brass or lead washers fitted to screws where required to protect metal surfaces and to make a weather tight connection.**
 - 4. Form closely fitted joints with exposed connections accurately located and secured.**
 - 5. Provide perimeter reveals and openings of uniform width for sealants and joint fillers, as indicated.**
 - 6. Repair finishes damaged by cutting, welding, soldering, and grinding. Restore finishes so no evidence remains of corrective work. Return items that cannot be refinished in the field to the factory, make required alterations, and refinish entire unit or provide new units.**
 - 7. Provide concealed gaskets, flashings, joint fillers, and insulation as louver installation progresses, where weather tight louver joints are required.**
- D. Clean exposed surfaces of louvers and vents that are not protected by temporary covering, to remove fingerprints and soil during construction period. Do not let soil accumulate until final cleaning. Restore louvers and vents damaged during installation and construction so no evidence remains of corrective work. If results of restoration are unsuccessful, as determined by Architect, remove damaged units and replace with new units.**

3.8 FIELD QUALITY CONTROL

- A. Protect duct interiors from moisture, construction debris and dust, and other foreign materials. Comply with SMACNA's "IAQ Guidelines for Occupied Buildings Under Construction," Appendix G, "Duct Cleanliness for New Construction Guidelines."
- B. HVAC systems shall not be operated during construction.
- C. Systems shall not be operated without filters in place.
- D. Upon completion of installation duct systems and before HVAC system start-up, visually inspect the ductwork proper installation
- E. Cover supply openings with filter media prior to system start-up to catch any loose material that may remain inside the ductwork. Turn the HVAC system on and allow it to run until steady state operation is reached. Remove the temporary filter media from supply openings and, along with it, any loose material blown downstream and caught by the filter media.
- F. All ductwork shall be provided with temporary enclosures to keep the HVAC system free of dust and construction debris. The HVAC system includes any interior surface of the facility's air distribution system for conditioned spaces and/or occupied zones. This includes the entire duct from the points where the air enters the system to the points where the air is discharged from the system.
- G. Check all filters in accordance with their manufacturer's instructions. Use specified grade of filters at all times that system is operating.

END OF SECTION 233113

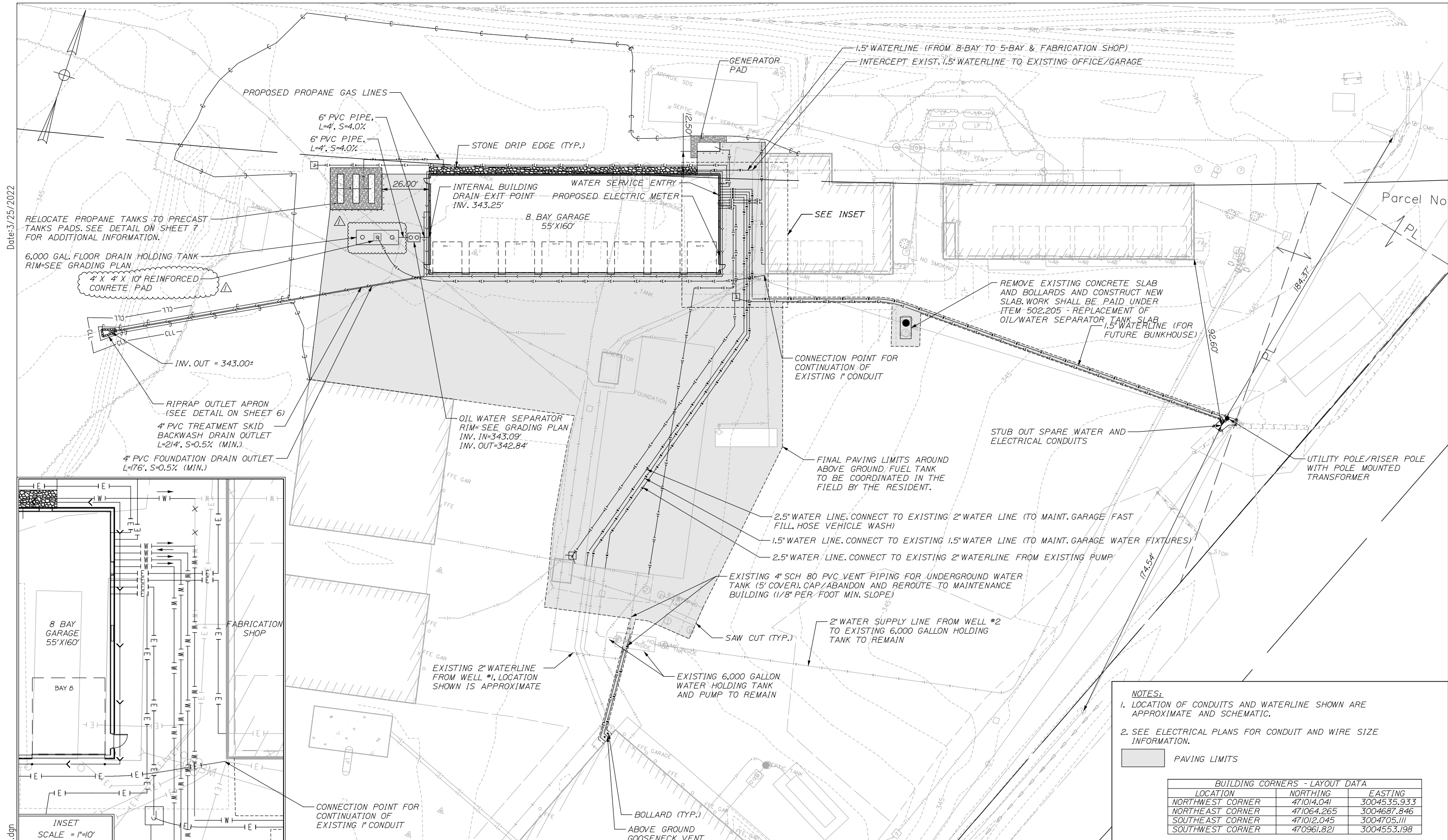

Date: 3/25/2022

Filename: OXX_Site&UtilityPlan.dgn

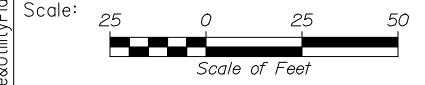
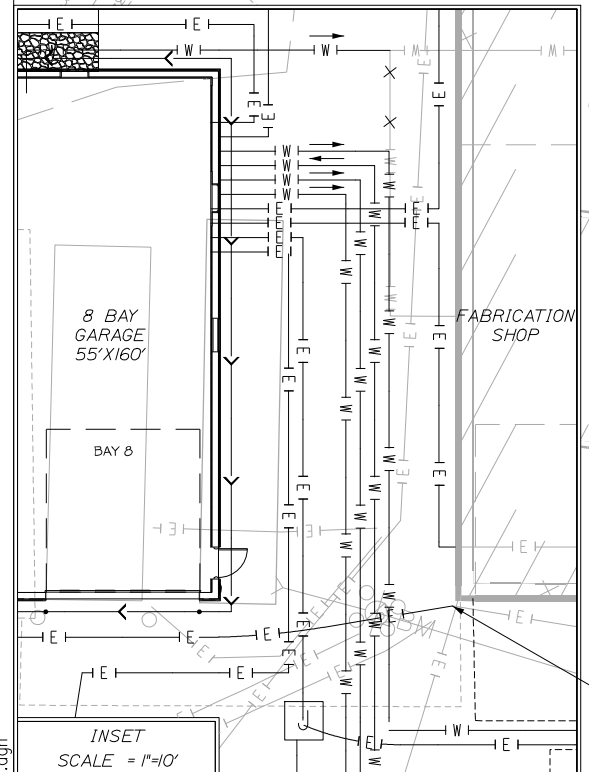

Designed by:



HNTB CORPORATION
 82 Running Hill Road, Suite 201
 South Portland, ME 04106
 TEL (207) 774-5155
 FAX (207) 228-0909



THE GOLD STAR
 MEMORIAL HIGHWAY

LITCHFIELD 8-BAY GARAGE REPLACEMENT
 SITE & UTILITY PLAN

- NOTES:**
1. LOCATION OF CONDUITS AND WATERLINE SHOWN ARE APPROXIMATE AND SCHEMATIC.
 2. SEE ELECTRICAL PLANS FOR CONDUIT AND WIRE SIZE INFORMATION.

PAVING LIMITS

BUILDING CORNERS - LAYOUT DATA		
LOCATION	NORTHING	EASTING
NORTHWEST CORNER	471014.041	3004535.933
NORTHEAST CORNER	471064.265	3004687.846
SOUTHEAST CORNER	471012.045	3004705.111
SOUTHWEST CORNER	470961.821	3004553.198

No.	Revision	By	Date
▲	ADDENDUM 2 - NEW 18" MANHOLE	PEM	3/22

CONSULTANT PROJECT MANAGER: Timothy R. Cote, P.E.

	By	Date	By	Date	
Designed	PEM	03\22	Checked	DAM	03\22
Drawn	PEM	03\22	In Charge of	TRC	03\22

MTA PROJECT MANAGER: Brian Taddeo, P.E.

CONTRACT:2022.08

SHEET NUMBER: C-102

4 OF 35

Date: 3/25/2022

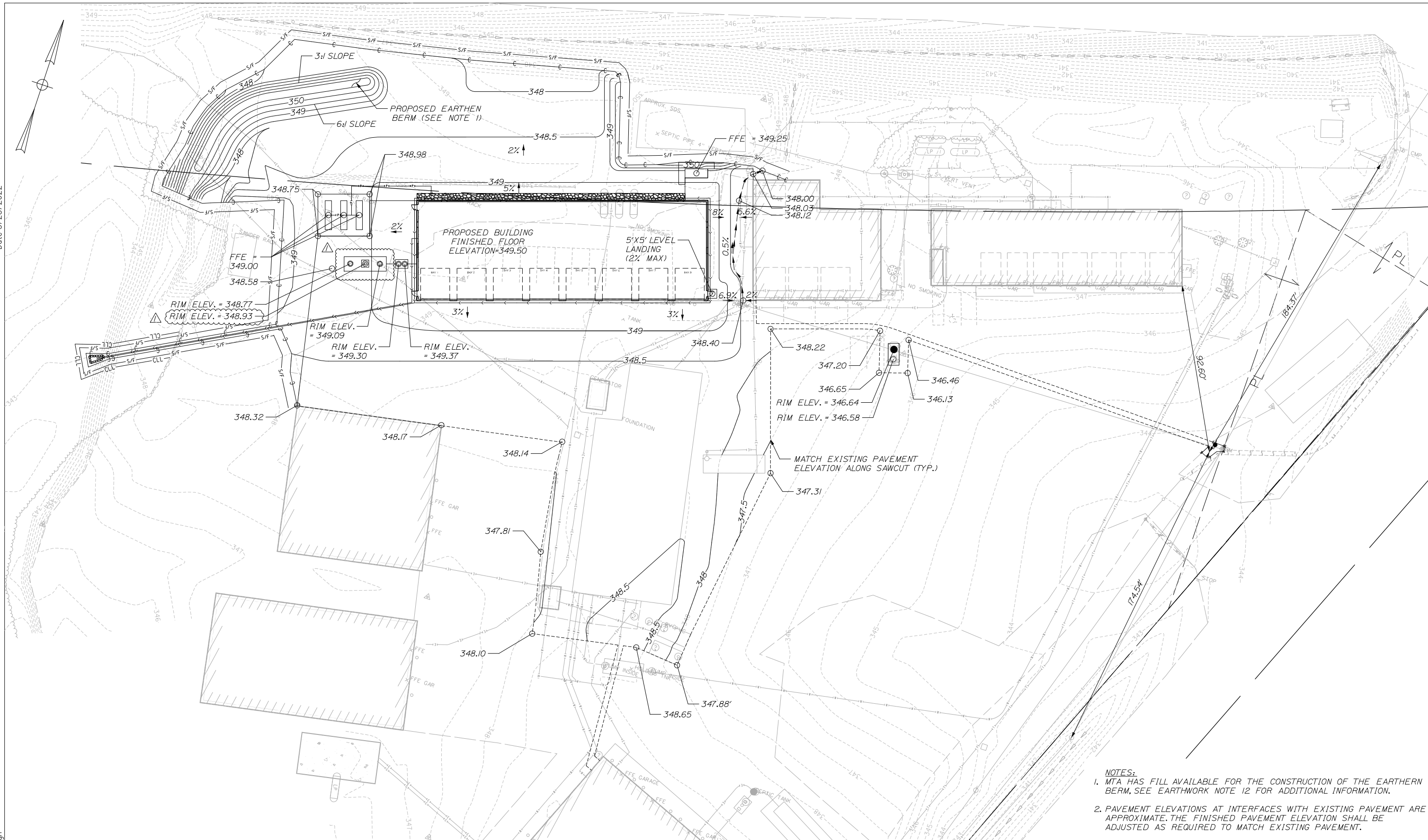

NOTES:
 1. MTA HAS FILL AVAILABLE FOR THE CONSTRUCTION OF THE EARTHEN BERM, SEE EARTHWORK NOTE 12 FOR ADDITIONAL INFORMATION.
 2. PAVEMENT ELEVATIONS AT INTERFACES WITH EXISTING PAVEMENT ARE APPROXIMATE. THE FINISHED PAVEMENT ELEVATION SHALL BE ADJUSTED AS REQUIRED TO MATCH EXISTING PAVEMENT.

Scale: 25 0 25 50
 Scale of Feet

No.	Revision	By	Date
1	ADDENDUM 2 - NEW 18" MANHOLE	PEM	3/22

Designed by:

CONSULTANT PROJECT MANAGER: Timothy R. Cote, P.E.

	By	Date	By	Date
Designed	PEM	03\22	Checked	CDH 03\22
Drawn	PEM	03\22	In Charge of	TRC 03\22

HNTB CORPORATION
 82 Running Hill Road, Suite 201
 South Portland, ME 04106
 TEL (207) 774-5155
 FAX (207) 228-0909

**THE GOLD STAR
 MEMORIAL HIGHWAY**

MTA PROJECT MANAGER: Brian Taddeo, P.E.

LITCHFIELD 8-BAY GARAGE REPLACEMENT
 GRADING, DRAINAGE, &
 EROSION CONTROL PLAN
 SHEET NUMBER: C-103
 CONTRACT: 2022.08
 5 OF 35

Date: 3/25/2022

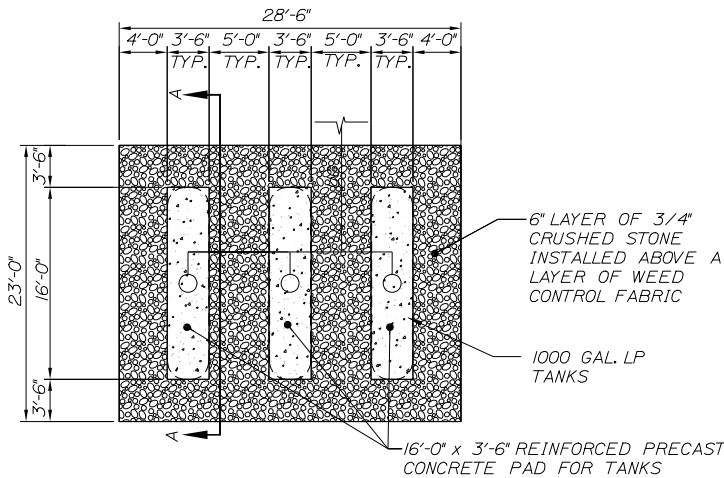
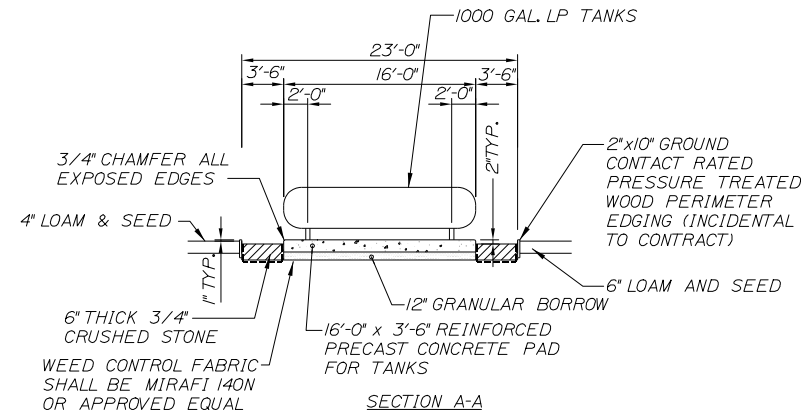

NOTE:
1. PROPANE TANK DIMENSIONS ARE APPROXIMATE AND SHALL BE VERIFIED BY THE CONTRACTOR.

ABOVE GROUND PROPANE GAS TANK FARM
NOT TO SCALE

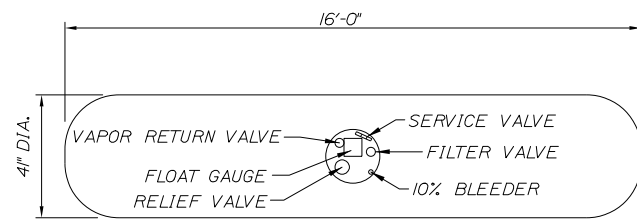

NOTE:
1. USE EXISTING TANKS OR AMERICAN WELDING & TANK ASME TANK OR APPROVED EQUAL TANK INSTALLATION TO BE COORDINATED WITH THE LOCAL GAS UTILITY COMPANY, AND SHALL COMPLY WITH ITS STANDARDS.

1,000 GALLON PROPANE GAS STORAGE TANK
NOT TO SCALE

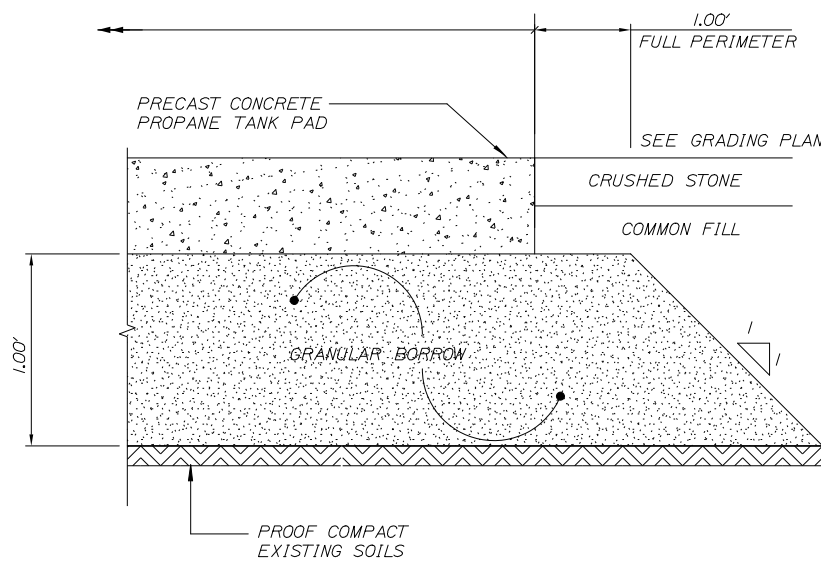

NOTE:
1. THE CONTRACTOR SHALL SUBMIT DESIGN CALCULATIONS FOR THE CONCRETE PROPANE TANK PAD IN ACCORDANCE WITH SPECIAL PROVISION 502.

PRECAST CONCRETE PROPANE TANK PAD
NOT TO SCALE

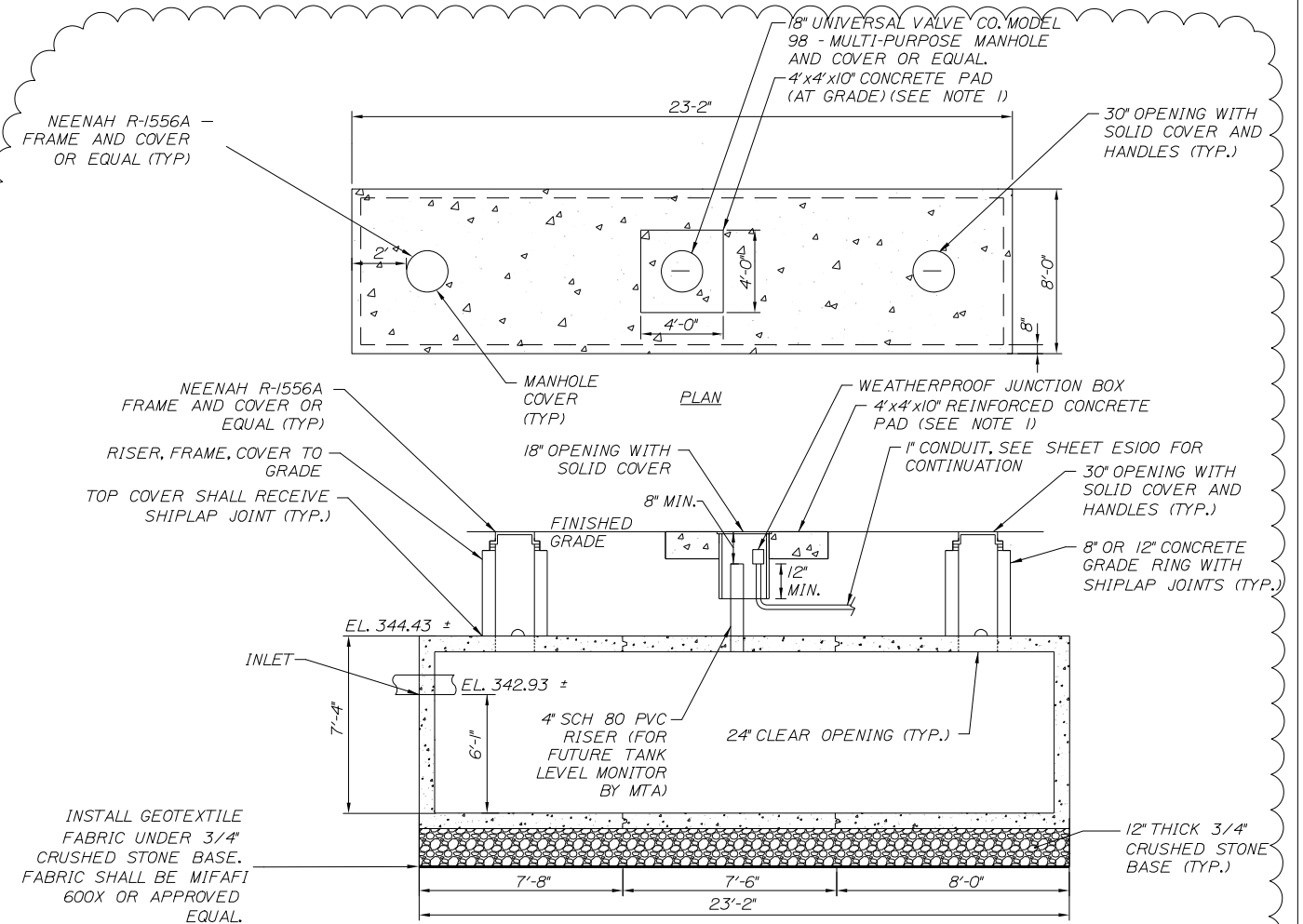

NOTE:
1. THE PROPOSED 4'x4'x10\"/>

6,000 GALLON HOLDING TANK
NOT TO SCALE

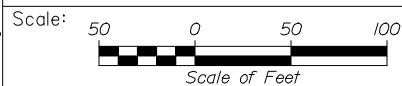

Designed by:



HNTB CORPORATION
82 Running Hill Road, Suite 201
South Portland, ME 04106
TEL (207) 774-5155
FAX (207) 228-0909



THE GOLD STAR
MEMORIAL HIGHWAY

LITCHFIELD 8-BAY GARAGE REPLACEMENT

DETAILS SHEET 2

No.	Revision	By	Date
ADDENDUM 2	- NEW 18\"/>		

CONSULTANT PROJECT MANAGER: Timothy R. Cote, P.E.

	By	Date	Checked	By	Date
Designed	PEM	03\22		DAM	03\22
Drawn	PEM	03\22	In Charge of	TRC	03\22

MTA PROJECT MANAGER: Brian Taddeo, P.E.

CONTRACT: 2022.08

SHEET NUMBER: C-402

7 OF 35

Filename: OXX_Details2.dgn

Date: 3/25/2022

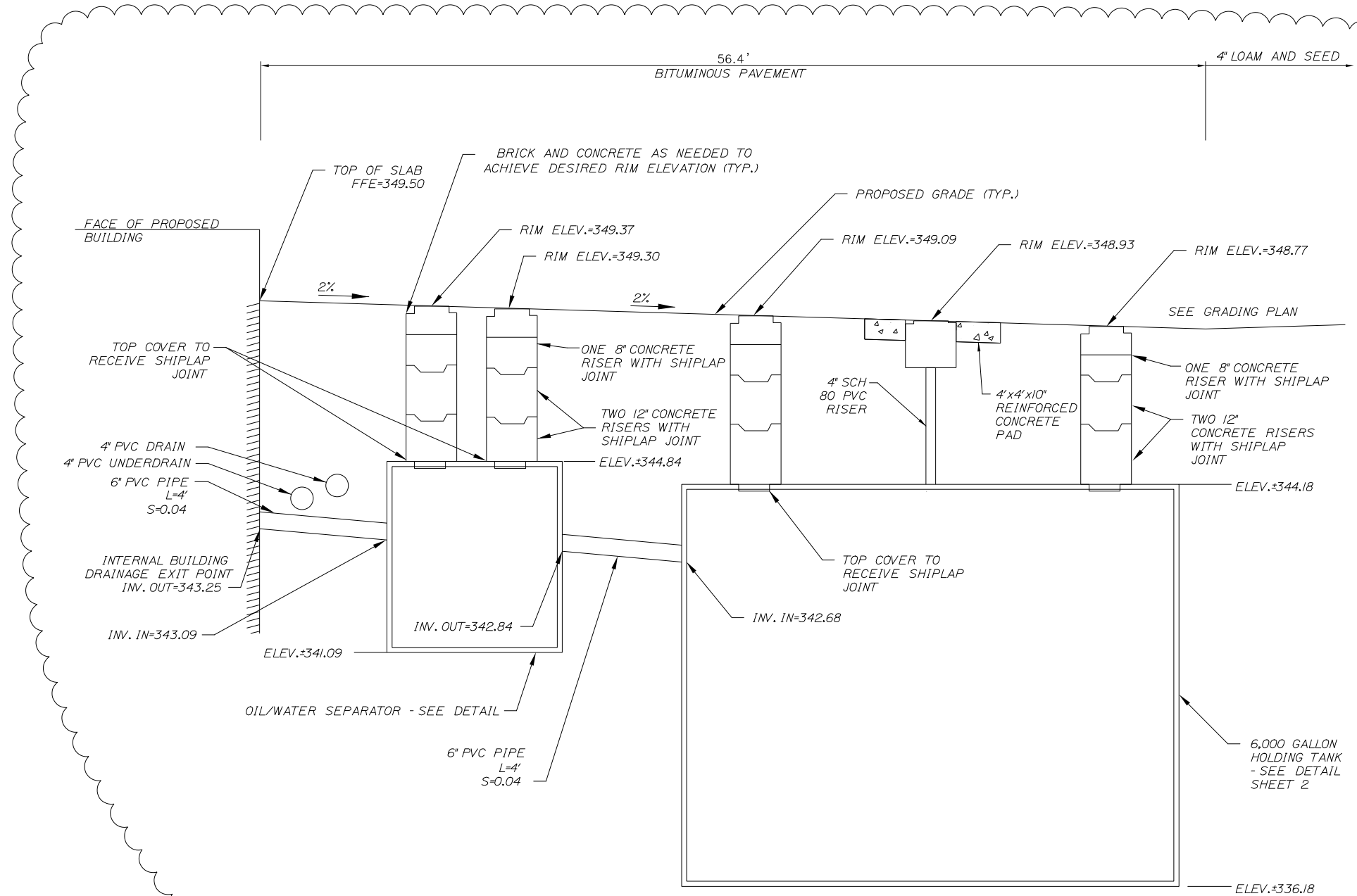

HOLDING TANK AND OIL/WATER SEPARATOR DETAIL
NOT TO SCALE

NOTE:
DESIGN SHOWN IS FOR ILLUSTRATIVE PURPOSES. CONTRACTOR IS RESPONSIBLE FOR DESIGN, FURNISHING, AND INSTALLATION OF HOLDING TANK AND OIL/WATER SEPARATOR. REFER TO SPECIAL PROVISION 604 FOR ADDITIONAL INFORMATION.

Scale: 50 0 50 100
Scale of Feet

No.	Revision	By	Date
1	ADDENDUM 2 - NEW 18" MANHOLE	PEM	3/22

Designed by:

HNTB

CONSULTANT PROJECT MANAGER: Timothy R. Cote, P.E.

	By	Date	By	Date	
Designed	PEM	03\22	Checked	DAM	03\22
Drawn	PEM	03\22	In Charge of	TRC	03\22

HNTB CORPORATION
82 Running Hill Road, Suite 201
South Portland, ME 04106
TEL (207) 774-5155
FAX (207) 228-0909

MAINE TURNPIKE

THE GOLD STAR MEMORIAL HIGHWAY

MTA PROJECT MANAGER: Brian Taddeo, P.E.

LITCHFIELD 8-BAY GARAGE REPLACEMENT

OIL/WATER SEPARATOR DETAIL

SHEET NUMBER: C-404

CONTRACT: 2022.08

9 OF 35

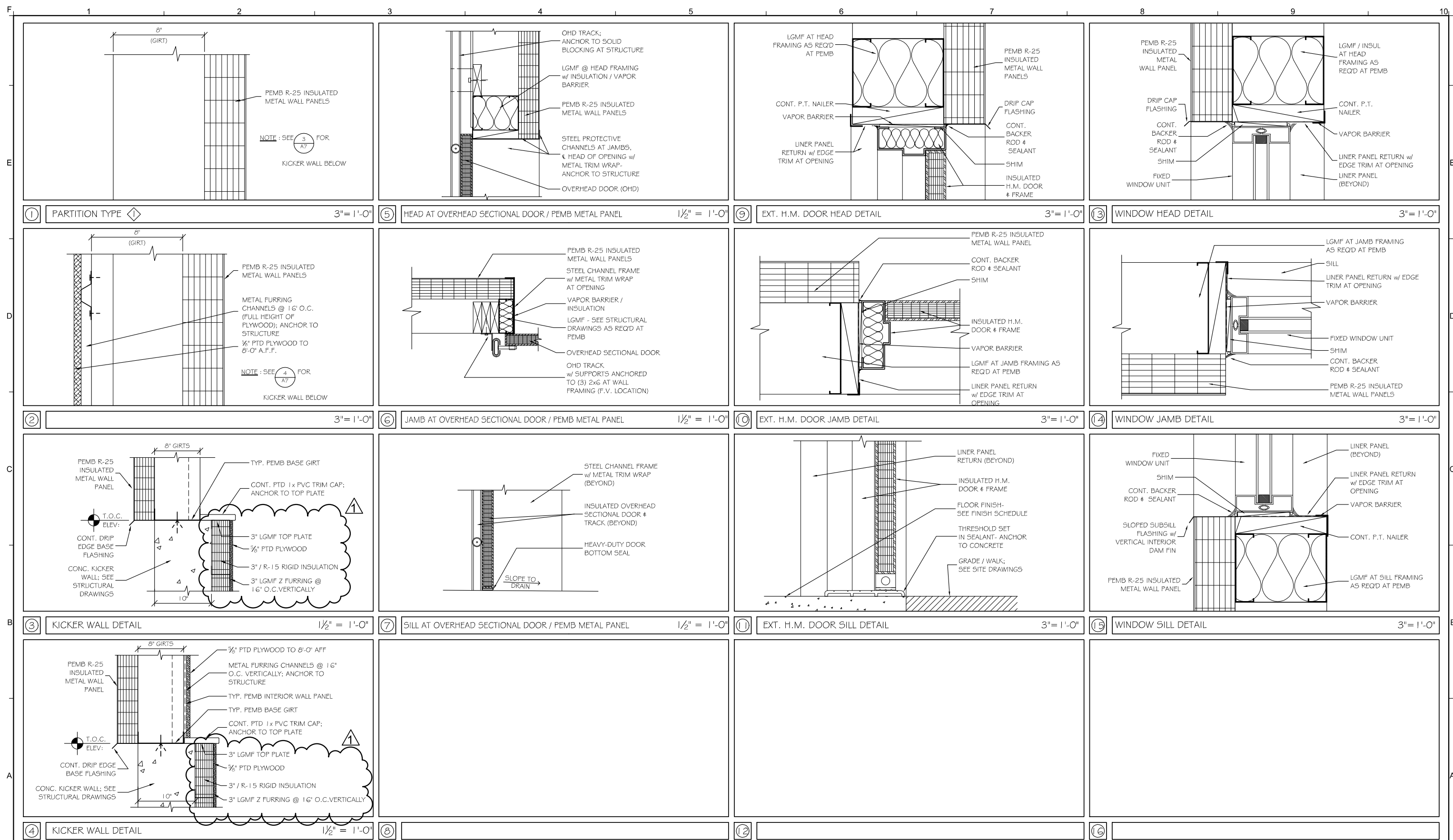

Scale: AS NOTED

No.	Revision	By	Date
1	KICKER WALL / PIERS	GHA	03.21.22

Designed by:
MICHAEL F. HAYS, RA
 ISSUED FOR BID

Designed: MFH 03/01/2022
 Checked: MFH 03/01/2022
 Drawn: MGK 03/01/2022

GRANT HAYS ASSOCIATES
 ARCHITECTURE & INTERIOR DESIGN
 P.O. BOX 6179 FALMOUTH MAINE 04103
 207.871.5900 www.granthays.com

MTA PROJECT MANAGER: **Brian A. Taddeo, P.E.**

LITCHFIELD 8-BAY GARAGE REPLACEMENT

DETAILS

SHEET NUMBER: **A-7**

CONTRACT: 2022.08

18 OF 35